

Project #6: Physiologic Metronome

Mid-Semester Report

October 21, 2009

Prepared by:

Ben Fleming (Communicator)

Cole Drifka (BWIG)

Jeff Theisen (BSAC)

Adam Pala (Team Leader)

Client(s):

Dr. Bill Fahl, Department of Oncology (University of Wisconsin-Madison)
Vanessa Young, Undergraduate Music Student (Carnegie Mellon University)

Advisor:

Dr. Paul Thompson, Department of Biomedical Engineering (University of Wisconsin-Madison)

Table of Contents

Problem Statement	3
Background Information	3
Design Motivation	4
Client's Requirements and Design Constraints	4
Human Factors and Ergonomics	4
Design Alternatives	5
• Permanent Features of the Design	5
• Type of Tactile Stimulus	6
• Location of the Tactile Stimulus	9
• Mode of Attachment of the Tactile Stimulus	13
• User Input and Output	15
Proposed Design	17
Future Work	18
Ethical Considerations	18
References	18
Appendix	19
• Product Design Specifications (PDS)	19

Problem Statement

The purpose of this design project is to develop a metronome device which will maintain a constant, adjustable tempo for the practicing musician. A key feature that the client requires is that the device's tempo-maintaining mechanism be inaudible. Such a feature allows the musician to practice and improve musical performance using a more intuitive approach—one that does not distract the musician while playing music (i.e. audible ticks, as used in conventional metronomes).

Background Information

Metronomes are defined as any device that provides a regular beat [1]. In most cases, metronomes are used to provide timing or rhythm to musicians. Metronomes use visual, auditory, and tactile stimuli to provide the musician a set tempo.

Classically, metronomes have used a mechanical mechanism to provide the timing or beat to the musician. The type of mechanical metronome that we are familiar with today was patented in 1816 by Johann Malzel [1]. This type of metronome uses an inverted double pendulum with a sliding weight so as to adjust the tempo. See the figure below.



Today, electronic metronomes are the most popular. These metronomes use an electronic circuit to provide a varying tempo output. The circuit does this by making use of typical circuit devices such as 555 timers to give a periodic signal. The periodic signal the circuit outputs is a repeating voltage drop. This output from the circuit is then supplied to a specific device to provide either an audible, visual, or tactile stimulus. If the stimulus is to be auditory, then the circuit is hooked up to a small speaker. If the stimulus is to be visual, then often an LCD or similar display is used to convey the rhythm to the user. This option is slightly more difficult to construct as it usually involves some sort of frequency counter and analog to digital conversion [2]. Lastly, if the stimulus is to be tactile, then an electric motor is often used to provide a vibration. However, there are no known metronomes that use a tactile stimulus that is adequate and distinct enough to provide the musician with accurate timing.

Design Motivation

The motivation for our design comes from Vanessa Young, a music student at Carnegie Mellon, and the niece of our client, Dr. Bill Fahl. According to Vanessa, a professional harp player, there is no adequate metronome that uses a tactile stimulus to indicate the user of the tempo. The main problem with metronomes that use an auditory stimulus is that the sound of the device can often be more distracting than helpful in keeping rhythm. A tactile stimulus is thus ideal for a couple of reasons. First, according to Vanessa, a tactile stimulus should be less distracting than an audible tone when trying to practice and play music. Also, a tactile stimulus, especially if applied at a point on the body of the proper sensitivity and association, would better allow the musician to “internalize” the beat of the music. Thus we sought to design and construct a metronome that made use of a tactile stimulus to accurately provide the user with tempo.

Client’s Requirements and Design Constraints

The client provided several specifications for the design of the physiologic metronome device. The key point which was stressed by the client—and is incidentally a focal point of the design—is that the tactile-stimulus mechanism be essentially inaudible. This is quite a radical departure from the conventional metronome; nevertheless, maintaining the tempo using an audible stimulus, as is done in many conventional metronomes, is indeed distracting for a musician. Furthermore, a direct tactile stimulus facilitates internalization of the rhythm for the musician, a point which was highly emphasized by the client.

Another set of specifications were established regarding the size of the device. For the sake of practicality, the client requires a metronome device which is portable, with dimensions comparable to other metronomes or other such consumer electronics. This is ideal for everyday use of the metronome device, as this is its intended purpose.

Accuracy and reliability constitute another set of important requirements. In order for the metronome device to be useful, it must maintain a constant tempo. Furthermore, the device should be able to reliably maintain this constant tempo in a typical practice environment (i.e. ambient temperature).

Finally, a \$100 budget was stipulated by the client. This is a very reasonable budget, given the relatively inexpensive cost of electronic components and all other miscellaneous accessories which will be included in the construction of the device. Specific discussion of the device’s various components shall be deferred to the *Design Alternatives* section.

Human Factors and Ergonomics

A primary concern in designing the physiologic metronome device is user comfort and adjustability. Given that a typical practice session may last upwards of an hour, the device should not be cumbersome and should not adversely affect the performance of the user while using the device (i.e. it should not cause any sort of additional fatigue in the course of playing the musical instrument). Furthermore, the device should not attach to the user in a manner which would physically interfere with the user’s ability to play the musical instrument while using the metronome device. Such considerations shall thus be made in the design of the device.

Design Alternatives

Permanent Features of the Design

Prior to discussing the various components of the design, it is worth mentioning two components which were considered “permanent” features of the design (i.e. they were not considered with other alternatives). The reason for not considering these with design alternatives is mainly due to the fact that these are trivial matters with respect to the client’s requirements. Their consideration does not reflect the discussion with the client and direct assessment of the client’s requirements and concerns.

The first such feature is the circuit. The circuit is relatively simple and was found by searching online for a metronome circuit [3]. It features a 555 timer configured for astable operation and a PNP bipolar junction transistor which amplifies the current at the output [4]. Several modifications were made to this circuit in designing the metronome device (cf. *Appendix*). The circuit is shown in the below.

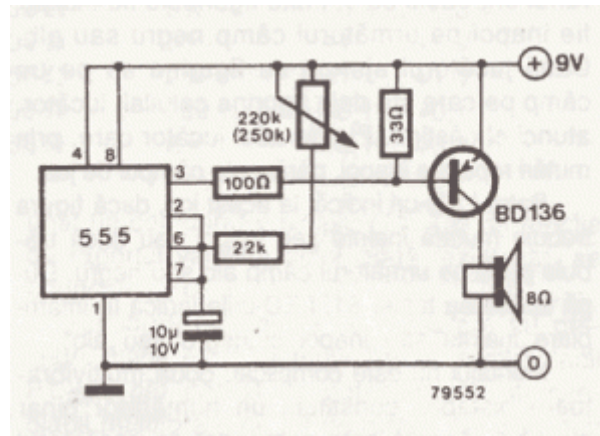

The second “permanent” feature is the case [5]. The case will house the circuit components (which will be mounted on a perf board), and will serve as the “command center” for the various components of the design. The case is shown below.

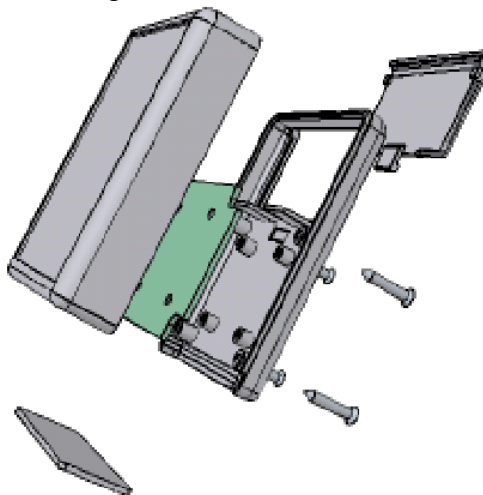

Type of Tactile Stimulus

The first main component of our design that we had to decide upon was the source of the tactile stimulus. As was mentioned earlier, current metronomes that make use of a tactile stimulus commonly employ a small electric motor to produce a repeated vibration. Thus, this was the first option which we considered. Also, we looked at a few other options, including a compression or “squeeze,” a shock, and a tap.

Vibration

First, we considered the option of using a vibration as the source of the tactile stimulus. The vibration would likely come from a small electric motor attached to the circuit. See the figure below.

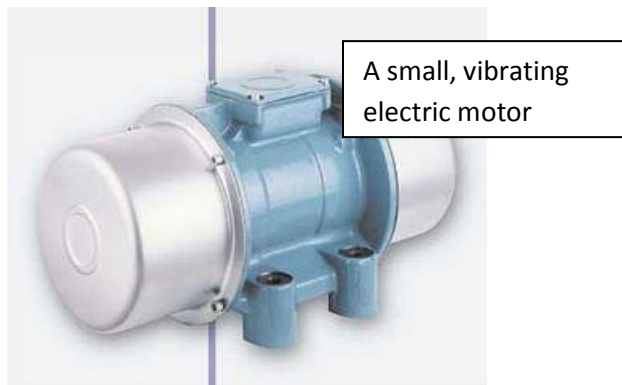

The electric motor would both be encased and mounted in the metronome/circuit case, or be attached externally to the metronome box. The sensation that the user would feel from this type of mechanism would be similar to the vibration felt by a cellular telephone in silent mode. There are a few main benefits that would be provided by this type of stimulus. First, the user would have no trouble in feeling the vibration, provided the electric motor were sufficiently powerful enough. Also, as this type of mechanism is already in limited use, we would have some basis for designing our instrument. However, there are a few main problems with this option. First and foremost, as this type of device already exists, we would have to find some way of applying this stimulus that overcame the problems with current devices. We are concerned that at high beats per minute (bpm), the user would lose the ability to distinguish between successive beats and would only feel a constant vibration. Lastly, it is preferred that the tactile stimulus occurs at the ear. Based on our research, it would be difficult and costly for us to find a vibrating electric motor which is sufficiently small enough to be viable for this location.

Compression

The next option that we considered was a compression or “squeeze” as the source of the tactile stimulus. The main concept behind this idea would be a band which wrapped around some part of the body, most likely the waist or arm. Internally, there would be a string with minimal slack that would shorten for each beat, thus providing compression at the given location. The internal shortening band would likely be attached to a small linear solenoid that had a pin which retracted for each voltage drop produced by the metronome circuit. This design provides some

important benefits. First, this type of stimulus would likely be the most comfortable for the user. Also, an elastic band made of some sort of mesh material may be the most aesthetically pleasing option. However, there are some downsides to this design. The main problem with this design would likely be the construction. First, we are unsure of exactly how we would attach the shortening string to the solenoid while at the same time placing it inside some sort of mesh band. Also, there may be some difficulty in constructing the band so that it tightens a sufficient amount for the user to feel, while at the same time not providing any pain or discomfort to the user. Also, as with the vibration, we are unsure what kind of resolution would be achieved with the compression option at high frequencies.

Shock

Another possibility for the tactile stimulus was a small shock. The idea behind this option is similar to that used in a domestic pet shock collar, although our shock would occur at a much smaller voltage. One possible mechanism comes from an idea for a specific pet training device. We would have a piezoelectric crystal in contact with a solenoid. See the figure below.

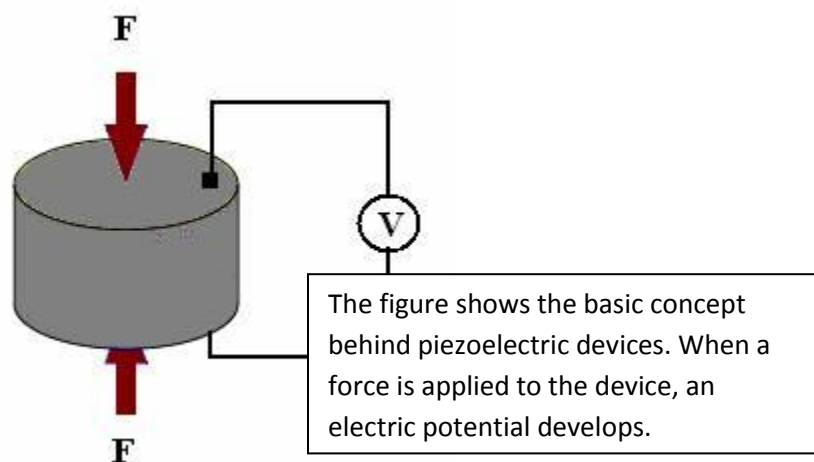

The solenoid would be hooked up to the circuit, and give a tap for each beat of the tempo. The tapping of the solenoid on the piezoelectric crystal would cause the emission of an electrical pulse which could be transmitted to the user via an electrode of sorts [6]. There are some benefits from using a shock to indicate the tempo of the music to the user. The device would stimulate the user through a small electrode attached to a wire. Thus this option would likely give the most options in respect to location and ease of attachment for the stimulus. However, there are several downsides to using a shock to stimulate the user. First of all, there is some concern as to the safety of this option. Electric shocks, if large enough, can be extremely harmful to the user. Although the shocks from our device would be sufficiently small enough so as to avoid harming the user, they could prove extremely irritating and distracting, especially at higher frequencies. Also, it might be difficult to maintain constant shock strength, as this value could change significantly depending on skin resistance. Skin resistance can vary from user to user and among different conditions, such as when the user is sweating.

Tap

The last option that we considered for the tactile stimulus was a small tap or mechanical pulse. This small tap would likely come from a linear solenoid directly in contact with the body. Although solenoids served a function in two of the three previous options for the tactile stimulus, in this case they would actually be the direct source of the tempo or beat. See the figure below.

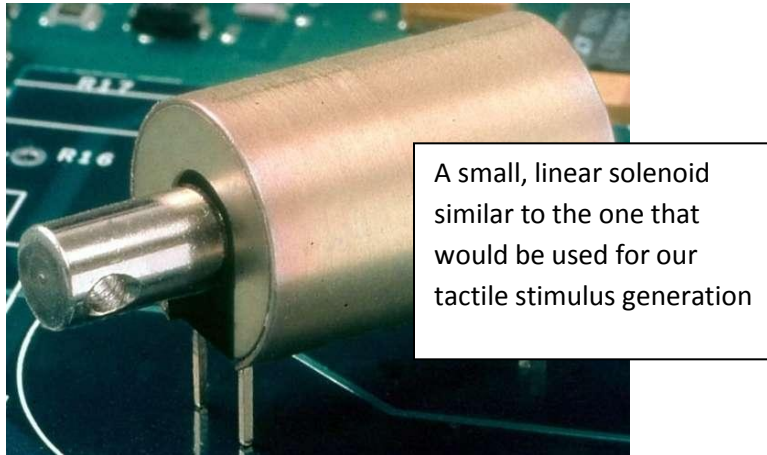

In engineering applications, a solenoid typically refers to a device which converts electrical energy into linear motion [7]. Thus in our design the device would take the electrical pulse from our circuit and convert it into a linear tap coming from a metal pin. This pin would contact the body and indicate the rhythm to the user. The solenoid would likely be encased and mounted in some small plastic box or mesh fabric and then attach to the body while being wired to the metronome and circuit. There are some downsides to this option. One main problem is that the smallest solenoids tend to be around a half inch in both diameter and height. Thus the size of the solenoid could limit where on the body the solenoid could be attached (i.e. the ear). Also, the weight of the solenoid could be an issue in the very same areas of the body. However there are a few key benefits that stem from this mechanism. The solenoid or tap option would likely give the best resolution between successive beats, even at high frequency. Also, the tap option would likely be relatively comfortable for the user, at least in comparison to the shock or vibration options. Lastly, the tap option would likely give the most specific or precise tactile stimulus. In other words, the stimulus would be felt at one distinct point on the body, especially if placed at a location on the body with good sensory perception.

All of the above options for the tactile stimulus were submitted into our design matrix shown below. As can be seen from the matrix below, signal resolution was the most important aspect considered, and this is the main reason for selection of the tap as the source of the tactile stimulus. Other important aspects of the design were size, user comfort, and lifespan.

Tactile Stimulus	User Comfort (20)	Resolution of Signal (40)	Lifespan (15)	Size of Tactile Generator (25)	Total (100)
Tap	15	37	11	15	78
Shock	7	27	14	20	68
Vibration	14	21	12	17	64
Compression	9	24	7	13	53

Location of the Tactile Stimulus

Once the type of tactile stimulus was chosen to best suit the project, the next logical step was to decide what anatomical attachment site would best accept a tactile tempo while still satisfying the client's demands. In considering locations, the question of sensory discrimination was the most heavily-weighted aspect of the decision process. Based on conversations with the client, the group decided to consider three potential locations on the body to deliver a tactile stimulus—the upper arm, the lower back, and the ear.

Upper Arm

The idea of attaching a tactile transducer to the upper arm would most likely be facilitated through an elastic strap comparable to the popular I-Pod docking band. Obvious advantages to this location would be ease of attachment and comfort of attachment, and bands are readily available on the market. Even though the upper arm may be a plausible location for some instrumentalists, it soon became apparent that it would be less than desirable for a harpist such as the client. In speaking to the client, she indicated that the right upper arm is in constant contact with the harp. Additionally, the left arm is slightly raised. With long durations of playing, issues of fatigue and possibly tendinitis were concerns expressed by the client.

To estimate the ability for different body regions to discriminate tactile stimuli, the two-point discrimination test was researched. Physiologically, sensory input pours into the central nervous system in a topographically-faithful manner [8]. Although tactile sensory maps in the cerebral cortex are faithful to the locations of the sensory receptors, they do not reflect the correct proportions of the skin areas [8]. In essence, receptor density and the sizes of receptive fields determine two-point discrimination ability [8]. This phenomenon can be illustrated by a sensory homunculus. In this, it is obvious that the ability of the upper arm to sense tactile stimuli is small compared to surface area. One study of 46 individuals revealed that the upper arm can discriminate two points when they are 42.4 mm apart on average [9]. When this fact is combined

with the possibility of the arm moving during playing, tactile discrimination arises as a major question.



Possible means of attaching tactile transducer to upper arm via I-Pod docking band. From store.apple.com/sg/product/MA663G/A.

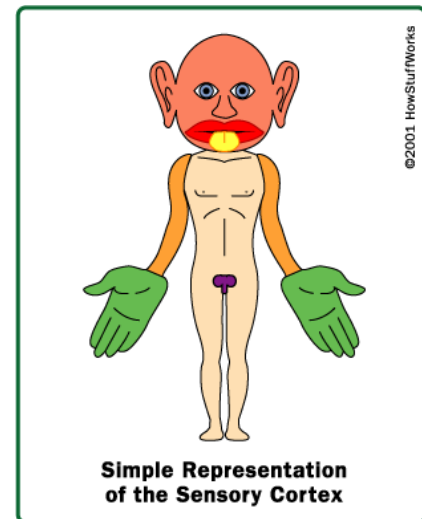

Sensory homunculus illustration. The upper arm and lower back arm less able to discriminate tactile stimuli that the ear region. From howstuffworks.com.

Lower Back

The second region considered was the lower back. Initial brainstorming proposed attaching a transducer to the region by either a belt or an “anchoring cap” as shown below. As opposed to the upper arm, the transducer would not be in contact with the client’s instrument. Additionally, it would be immobilized to the central spinal region assuming that the user remained seated. Also, whereas the arm attachment site may cause the device to be more noticeable, the lower back would promote concealment under clothing.

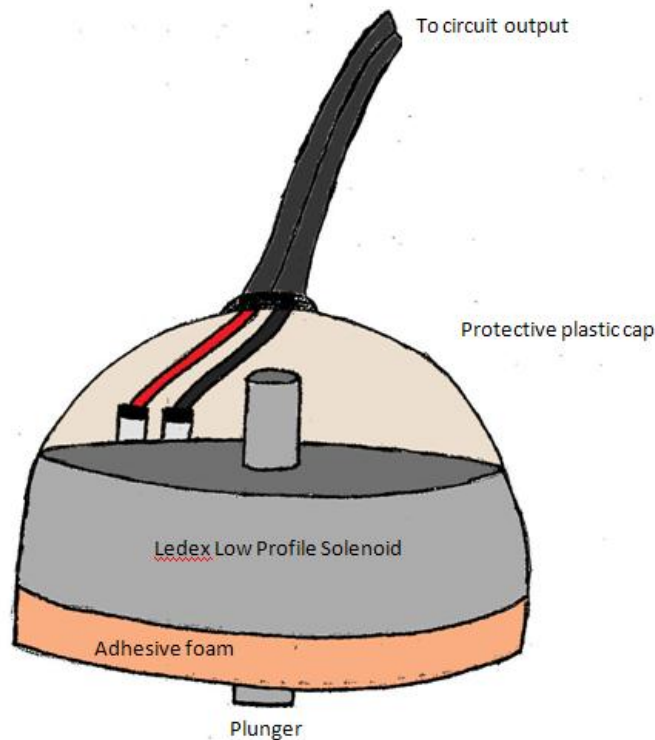

Sketch of “anchoring-cap” attachment device to the lower back. An adhesive ring would position the tactile device on the lower back.

However, attaching a transducer to the lower back could be cumbersome—especially if adhesive material had to be constantly replaced, as the anchoring cap idea would necessitate. Additionally, the ability of the lower back to discriminate stimuli is a question. In a study of lower back two-point discrimination, it was found that on average individuals were able to discriminate points 41.8 mm apart [10]. This is very close to the sensory ability of the upper arm; both prove to be inferior to the ear option.

Ear

From the start of the project, the client has shown preference towards delivering tactile stimuli to regions proximal to the ear. In a study of 105 subjects, two-point discrimination results were 20.3 mm on average for the ear lobe region [11]. This is considerably more sensitive than the upper arm or lower back. Also, the ear is most proximal to the auditory processing lobe of the brain, which may lead to a more natural “internalization of the beat.” If attached to a metronome circuit via an output wire, an ear device would not interfere with the playing of an instrument.

The major issues surrounding delivering tactile stimuli to the ear region is attachment. First of all, the transducer has to maintain a stable position so the perceived magnitude of the delivered stimulus does not fluctuate. Potential means of attaching an ear device may be through an ear clip, an ear form adapter, or a behind-the-ear design. Currently, the Peterson BB1 BodyBeat Pulsating Metronome is a product on the market that employs a vibrating clip [12]. However, this clip is not specific for the ear. Also, reviews have shown that tactile discrimination

may be difficult with this product. Considering this, a design that is specific to a user's ear may more effectively transmit a tactile musical tempo.

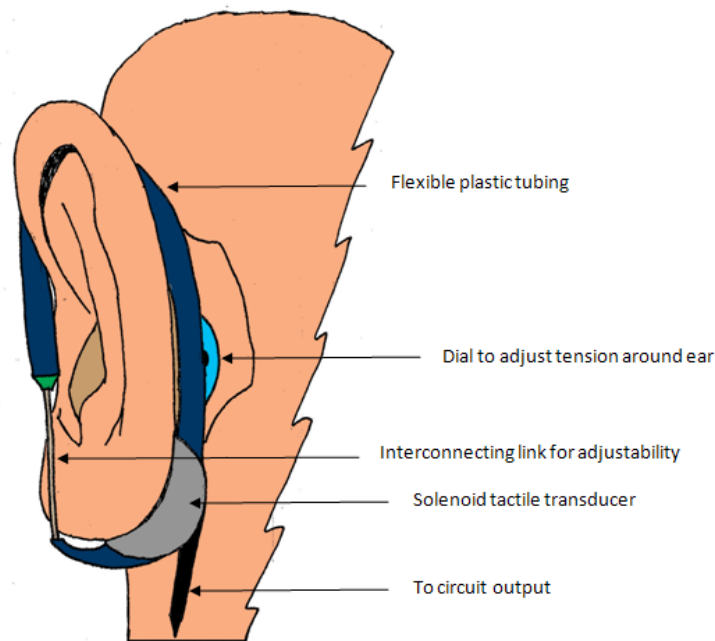

A possible design to attach a tactile transducer behind the ear. A miniature solenoid would need to be used to avoid discomfort. The ability to adjust tension would promote user specificity.

All three of the aforementioned body locations were subjected to the design matrix shown below. Although the ear may be the most difficult location to attach a transducer device to, its superior ability to perceive an incoming tactile signal makes it the most practical option to pursue.

Location of Stimulus	User Comfort (30)	Resolution of Signal (40)	Ease of Attachment (25)	Visual Appeal (5)	Total (100)
Lower Back	25	30	18	4	77
Ear	22	36	17	4	79
Upper Arm	20	25	21	3	69

Mode of Attachment of the Tactile Stimulus

In order for the metronome to function well, it must be secured to the body in some way. Although the best mode of attachment may be dictated by the location of the stimulus, there are many methods of attachment that apply to any location on the body; thus the mode of attachment was considered as one of the major topics for design alternatives. There are a variety of possibilities for meeting this requirement; the three main alternatives that were considered include adhesive, elastic, and form-fitting, the latter of which may require additional explanation. A form-fitting device, as it will be used in this paper, is one that can be adapted to fit the shape of any body, and this may differ depending on the location. An example of a form-fitting device for the upper arm would likely be very similar to an adjustable elastic armband. However, elastic would not be a form-fitting device if applied to the ear. In this case a malleable loop, similar to that used for headphones, to go above and around the back of the ear would adapt to the shape of the ear much better.

Adhesive

Adhesive patches could be used to secure the metronome to the body. This type of attachment would be very similar to that of a band aid, except with a metronome in place of the gauze pad. One advantage of this design is that it could be placed just about anywhere, as the adhesive patches can be stretched to fit any shape. It would also be very quick to put this on. Like a typical band aid, this type of attachment would be very stable unless the user began sweating.

There are a number of disadvantages to this design. The adhesive would eventually wear out after a couple of uses, and will need to be replaced. Depending on how frequently the metronome is used, the adhesive may need to be replaced quite often, and it would be a hassle and potentially costly. Additionally, ripping of adhesives is sometimes uncomfortable for the skin and thus undesirable.

Elastic

Another possible mode of attachment is elastic, most likely in the form of an adjustable strap on which the tactile transducer is mounted. The elastic strap has many advantages. First of all, elastic straps are widely available, so that an ideal size and design would be easy to find. For the same reason, little effort would be needed to construct this type of attachment. An elastic strap is also a very secure attachment, which will hold the tactile device snugly against the body.



One of the downsides of the elastic strap is that it would be hard to design for some parts of the body. For example, an elastic strap would not easily fit around the ear, so if this location were used the elastic strap would have to wrap around the head, like a headband. It may also add extra weight to the limbs of the body, throwing off balance or increasing the rate of fatigue.

Form-Fitting

The final alternative for mode of attachment is form-fitting, which was defined above as a device that can adapt to fit the shape of any given body. This alternative was designed with the ear in mind. The main advantage for this design is that it can be adjusted by the user to fit the user's body, thus providing a high level of comfort. It would also be a very visually appealing design. For example, using a loop that runs above and behind the ear, similar to that used for headphones or hearing aids, looks simple and elegant.



<http://www.soundearphones.com/shop/skullcandy/earphones/343-skullcandy-asym-earphones-blackgreen/>

There are some disadvantages for this mode of attachment. It would be more difficult to design and construct. In addition, it may not be as stable and secure as the other modes of attachment, especially considering that the tactile device will likely involve some motion, which could jostle the attachment.

For this design matrix, user comfort was most heavily weighted. This is because the device is intended for long periods of use, and must be comfortable so that the user can concentrate on the music. An uncomfortable metronome could be so uncomfortable as to hinder the musician's practice. The next most important aspect is the stability of the attachment. If the tactile device can stay firmly attached to the body, the user may have trouble feeling the beat, thus rendering the metronome useless. The ease of construction was also considered, as the third most important, because there is a limited time in which to build the prototype. Furthermore, a complicated construction process could increase the cost of manufacturing, thus making it a less viable idea. The final aspect considered in the design matrix is the visual appeal. The device should look nice, so that the user could potentially use it in a performance setting.

Mode of Attachment	Stability (30)	User Comfort (35)	Ease of Construction (20)	Visual Appeal (15)	Total (100)
Adhesive	24	23	16	12	75
Elastic	26	25	18	10	79
Form-Fitting	22	31	14	13	80

User Input and Output

The final design alternative involves the interaction of the user with the device. Specifically, this involves two things, input and output, which deal with setting the tempo (input from the user) and indicating which tempo has been set (output to the user). User friendly operation and ease of construction were two contradictory ideas which required arbitration in determining the design. Three user input-output combinations were determined accordingly: knob and tick marks; knob and LCD display; and buttons and LCD display.

Knob and Tick Marks

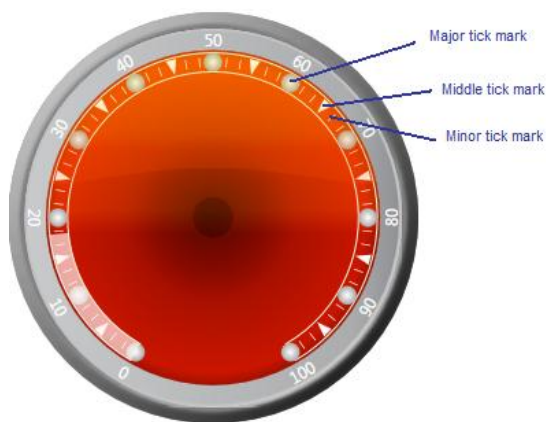

<http://www.telerik.com/help/wpf/images/RadialScaleTickMarks-Desc.png>



commons.wikimedia.org/wiki/File:Potentiometer.jpg

The first user input-output combination involves a knob (potentiometer) to adjust the tempo and tick marks to indicate which tempo has been set. Graded tick marks would indicate the full tempo range of the metronome device. Assuming proper calibration of the potentiometer to the tick marks, this would be the easiest-to-construct option and most cost effective, while accomplishing the basic requirements for a user input-output system.

The main disadvantage in this user input-output combination is a relatively low accuracy and precision in the indication of the tempo. This method is analogous to using a graded-temperature glass thermometer: the use of tick marks gives rise to poor measurements at intermediate values between tick marks. Such a design is thus highly dependent on the spacing of the tick marks. If the tick-mark intervals are too narrow, they may become cluttered and may result in difficult adjustability of the tempo; conversely, if the tick-mark intervals are too broad, it may be difficult for the user to assess if the desired tempo has been correctly chosen.

Knob and LCD Display



detail.en.china.cn/provide/detail,1078195290.html

The second user input-output combination similarly employs a knob (potentiometer) as the user input, but uses an LCD display to indicate the tempo (i.e. user output). This method is much more user friendly in terms of the output, as a digital display of the tempo (in beats per minute) is much easier to read than tick marks. This gives rise to easier adjustability for the user, and more confidence that the correct tempo value has been selected.

The main disadvantage of this user input-output combination is difficult in construction. Using a digital LCD display involves relatively complex circuitry and programming, two tasks which are difficult to achieve due to time and financial constraints, as well as poor knowledge of such circuitry. Thus, time is an issue in both construction and also acquiring the necessary knowledge to construct such an LCD display. Given finite time and rapidly approaching deadlines, this may be a difficult option to consider.

Buttons and LCD Display



<http://www.bigfoto.com/sites/galery/closeup1/digital-camera-buttons.jpg>

The third, final user input-output combination similarly employs an LCD display as the user output, but uses buttons to select the tempo (i.e. user input). This method is the most effective and user friendly in terms of both the user input and output. As was previously established, a digital display of the tempo (in beats per minute) is much easier to read than tick marks. Furthermore, the inclusion of easy-to-use buttons allows for a more compact design, as there are no protruding knobs. Thus, there is an added aesthetic element with this combination.

The disadvantages associated with this user input-output combination mainly involve an even greater complexity in the design. In addition to employing an already difficult-to-design LCD display, buttons would have to be incorporated into the process, adding more complex circuitry and programming to the design. This would also be the most expensive combination due to the additional parts that would be required to construct it. Furthermore, given time constraints, this combination is very impractical from a construction standpoint, despite its user friendliness.

After considering the three user input-output combinations, a design matrix with several criteria was established and is shown below. Ultimately, the decision came down to time and cost considerations, as well as a cost-benefit analysis of user friendliness versus practicality of construction. Given that discrete (i.e. integer value) tempo markings are sufficient for most musicians using a metronome, it was determined that the knob-and-tick-mark combination was the most viable option, due to the ease of construction balanced by sufficient user-output information provided to the user, given proper calibration and optimal selection of tick-mark intervals.

User Input/ Output	Ease of Use (30)	Ease of Construction (25)	Cost (15)	Accuracy/ Precision (30)	Total (100)
Knob/Tick Marks	24	24	13	22	83
Knob/LCD display	26	18	10	27	81
Buttons/LCD display	28	13	9	28	78

Proposed Design

Having considered the various design alternatives, a discussion of the overall proposed design is warranted. The case is the “command center” of the metronome design. It will contain the circuit elements which will be mounted and soldered onto a perf board. The potentiometer will be centered on the perf board, and a hole will be carefully drilled into the case to allow the potentiometer to protrude through the top of the case. Tick marks will be then calibrated to the protruding potentiometer, and will then be drafted and attached to the surface of the case. The potentiometer will then be covered with a knob which will indicate the tempo along the tick marks. Another hole will be drilled into the side of the case, which will reveal an audio-type output jack (this will replace the speaker in the circuit diagram shown in the *Design Alternatives* section). This will allow the solenoid-based tactile stimulus, which is attached to the ear in a form-fitting manner, to plug into the circuit located inside of the case. The tactile stimulus will thus be delivered in response to the user-adjusted tempo. A power switch will also be included to preserve battery life. The proposed solution is summarized in the figure below.

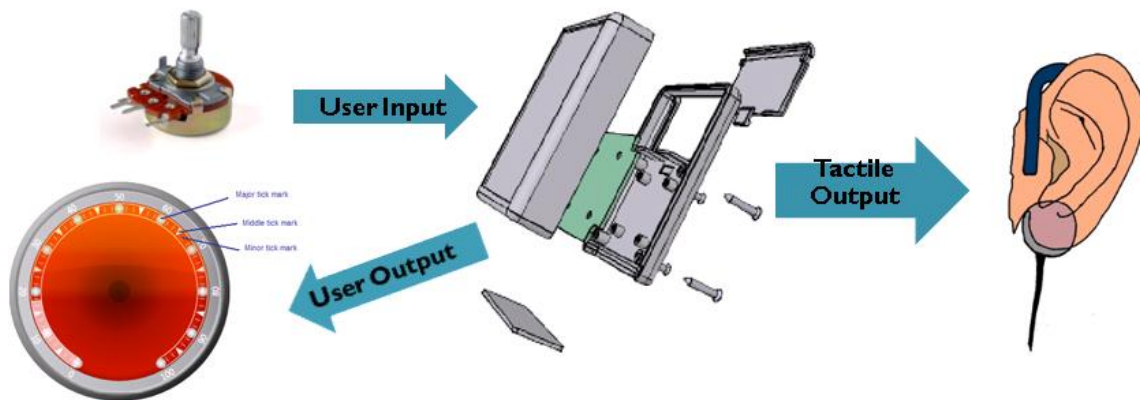

Future Work

In order to advance the current state of this project, parts will need to be ordered so that construction can begin. Once a prototype is built, it will be rigorously tested. The operating life of the circuit, battery, and tactile transducer will be tested in a lab setting. Also, it will be beneficial to compare the prototype to conventional visual and audio metronomes in terms of effectiveness. Questions regarding consistent tempo generation and the ability to sense the tactile tempo in different “distracting” environments could be answered by sampling a group of musicians on campus.

If the prototype appears to be effective, a more user-friendly interface that promotes programmable tempos and other advanced features could be desirable. Also, a feature that allows synchronization of multiple tactile metronomes could be advantageous for a concert setting.

Ethical Considerations

The physiologic metronome is intended for human users and will be used frequently, perhaps daily. A practice session may last hours, and so the device must be safe for long periods of time. Fortunately, there are not many potentially dangerous aspects to this project. The electrical components will obviously have to be encased and sealed away from the user. The only other possible hazard is the tactile stimulation. Shock may be harmful for users. For example, if used for a long period of time the electricity running through the body will cause it to heat up. Variation in skin resistance due to sweat could create a situation in which the shock delivered through the body is unsafe [13]. The other possibilities for tactile stimulation, which are mentioned above, should all be safe for human use, assuming the forces applied are within reasonable values.

References

1. Metronome. (2009). In *Columbia Electronic Encyclopedia*. Retrieved from <http://www.encyclopedia.com/topic/metronome.aspx>
2. Kobayashi, A. (2009). U.S. Patent No. 7,531,734. Washington, DC: U.S. Patent and Trademark Office.

3. Metronome circuit schematic. (2009). Electronic circuits.
<http://electroschematics.com/216/electronic-metronome-circuit-schematic/>
4. LM555. (2002). Fairchild Semiconductor Corporation.
<http://www.fairchildsemi.com/ds/LM/LM555.pdf>
5. Hand Held Instrument (1593P). (2009). Hammond Manufacturing.
<http://www.hammondmfg.com/pdf/1593P.pdf>
6. Hultine, J. D., and Clark, T. (1998). U.S. Patent No. 119,364. Washington, DC: U.S. Patent and Trademark Office.
7. Solenoid. (n.d.). <http://en.wikipedia.org/wiki/Solenoid>.
8. Murray, MA. "Our Sense of Touch." <http://faculty.washington.edu/chudler/twopt.html>
9. Nolan MF. Two-point discrimination assessment in the upper limb in young adult men and women. *Physical Therapy*. July 1982; 62; 965-969.
10. Peters ML, Schmidt AJ. A comparison of two-point discrimination threshold of tactual, non-painful stimuli between chronic low back pain patients and controls. *Pain*. 1991; 44; 57-60.
11. Costas, PD, Heatley G, Seckel BR. Normal sensation of the human face and neck. *Plastic and Reconstructive Surgery*. May 1994; 93; 1141-1145.
12. Peterson BB1 BodyBeat Pulsing Tactile Metronome.
<http://www.peterson.starborg.net/bb1.bodybeat.pulsing.tactile.metronome.html>
13. Electric Shock. 2009. Hyperphysics.
<http://hyperphysics.phy-astr.gsu.edu/hbase/electric/shock.html>

Appendix

Product Design Specifications (PDS)

I. Function

The purpose of this design project is to develop a metronome device which will maintain a constant, adjustable tempo for the practicing musician. A key feature that the client requires is that the device's tempo-maintaining mechanism be inaudible. Such a feature allows the musician to practice and improve musical performance using a more intuitive approach—one that does not distract the musician while playing music (i.e. audible ticks, as used in conventional metronomes).

II. Client Requirements

- The device should accurately maintain the tempo.
- The tempo-maintaining mechanism should be inaudible, relying on some sort of tactile stimulus to interface with the performer (i.e. something that can be internalized while playing without causing a distraction).
- The device should not attach to locations on the body such as the arm or wrist—which are used to play the instrument—but rather at a location such as the waist, where the device does not interfere with musical performance but can still be used by the performer to maintain the tempo while playing.
- The device is intended primarily for day-to-day practice.

III. Design Requirements

1. Physical and Operational Characteristics

- a. **Performance Requirements:** The tempo-maintaining mechanism must be essentially inaudible. The device should cover a practical playing-tempo range of approximately 40 to 250 beats per minute.
- b. **Safety:** The device must not cause excessive discomfort or harm to the performer.
- c. **Accuracy and Reliability:** The device must accurately and reliably maintain a constant tempo in a typical musical practice or performance environment.
- d. **Life in Service:** The device should be able to operate for the duration of a typical practice session (i.e. 2 to 3 hours at a time).
- e. **Shelf Life:** Indefinite; since the device will not involve any perishable materials, the shelf life is expected to be similar to that of typical consumer electronics devices.
- f. **Operating Environment:** Room temperature for a typical practice session, and possibly higher temperatures in densely crowded concert halls during performances (if applicable).
- g. **Ergonomics:** The device must be strategically placed on the body, so as to not adversely affect the performer's ability to play the instrument, and must be quickly adjustable and comfortable in a performance setting (if applicable).
- h. **Size:** The device should have a base of about 3 to 4 in by 3 in, and a height of about 0.5 to 1 in. Thus, the device should be portable and should not be cumbersome.
- i. **Weight:** The device should weigh approximately less than 1 lb. It should be lightweight in order to prevent distraction of the performer.
- j. **Materials:** Typical circuit elements (i.e. resistors, capacitors, 555 timer, etc.), a plastic case, and a battery (9 V).
- k. **Aesthetics:** The device should be rather plain in order to prevent attracting attention to it during practice or during a performance (if applicable). The device should attach firmly to the body and should not rattle or cause any other such undesirable noise.

2. Production Characteristics

- a. *Quantity*: One functional device.
- b. *Target Product Cost*: Up to \$100 for the production of a working prototype.

3. Miscellaneous

- a. *Standards and Specifications*: The device should have similar adjustability to other electronic metronomes, and it should be built in a manner which does not pose electrical hazards to the performer.
- b. *Customers*: Primarily the client, though there is a potential market for other musicians.
- c. *Patient-Related Concerns*: The device should be comfortable and should not harm the performer while playing music.
- d. *Competition*: Many electronic metronome devices are on the market, though few deal with the problem of an inaudible/tactile tempo-maintaining mechanism.