

# DESIGN OF A WEIGHT DISTRIBUTION MONITORING SYSTEM

---

December 12, 2012

**TEAM:**

Katherine Hildebrand- Team Leader

Scott Mawer- Communicator

John Diaz de Leon- BSAC

Russell Little- BWIG

**CLIENTS:**

Ms. Carol Rohl

Dr. Bonnie Tompkins

**ADVISOR:**

Professor Willis Tompkins

Professor, Department of Biomedical Engineering

## Table of Contents

Abstract.....	3
Problem Statement: .....	3
Background Information: .....	3
Design Motivation and Criteria: .....	4
Initial Design Ideas: .....	5
<i>Wii Balance Board:</i> .....	5
<i>Mechanical Balance:</i> .....	7
<i>Wheatstone Bridge Balance:</i> .....	8
<i>Feedback Displays:</i> .....	10
Decision Matrix Analysis: .....	11
Comparison of Mid-semester Design and Final Design: .....	13
Final Design: .....	14
<i>Sensors:</i> .....	14
<i>Platform:</i> .....	15
<i>Microcontroller:</i> .....	18
<i>Circuit:</i> .....	19
<i>Programming:</i> .....	19
<i>Output and LEDs:</i> .....	20
Testing: .....	21
Budget: .....	23
Future Work: .....	23
Conclusion: .....	24
Appendix: .....	25
References: .....	30

## **Abstract**

Ms. Carol Rohl is a hemiplegic woman who suffered a thalamic bleed in 2004. Our team has been approached to assist in her rehabilitation. Currently, she does not know when her stance is balanced due to a lack of sensory feedback on the left side of her body. She would like a portable weight distribution monitoring system that she can use to train herself to recognize an even weight distribution. Our team initially considered a Wii Balance Board, a mechanical balance, and a Wheatstone bridge balance as design alternatives. We ultimately decided to use two FSRs in a simple circuit, then implemented an Arduino microcontroller to compare the force difference between the FSRs. This number was shown to the user via instant feedback in a row of LEDs that indicated the degree of imbalance. By incorporating the circuit into a folding plate, we successfully implemented our client's requirements. As a team, we believe that this device has benefits for the growing field of stroke rehabilitation since it provides a way for stroke survivors to take an independent role in the recovery process through a portable and affordable device.

## **Problem Statement**

Ms. Carol Rohl is a hemiplegic patient who cannot feel the left side of her body. Due to the lack of sensory feedback, she often struggles to evenly distribute her body weight: rather than standing with her weight balanced, she tends to put most of her weight on the right side of her body. Ms. Rohl believes that, with the assistance of a device to measure her weight distribution, she could practice standing evenly and eventually improve her stance through visual reinforcement.

## **Background Information**

In 2004, Ms. Rohl suffered from a thalamic bleed, a normally fatal type of stroke in which a blood vessel ruptures in or near the thalamus. As a result, she lost a significant amount of the motor and sensory functions related to the left side of her body. Since her stroke, she has been undergoing physical therapy in hopes of restoring her sensory and motor capabilities; however, she has found these means insufficient for the degree of recovery she wishes to achieve and has begun pursuing alternative means to aid her in her recovery, which ultimately led to our design team.

Patients with post-stroke hemiplegia must learn to control muscular force in order to regain motor tasks. However, the muscle weakness in hemiplegic individuals results from both muscular and neural factors. Though the changes in muscle composition are somewhat inconclusive as it is difficult to isolate the effects of hemiplegia from general inactivity, researchers have concluded that hemiplegia results in type II muscle atrophy (Patten et al, 2004). This muscular atrophy contributes to the difficulty that hemiplegics may experience when attempting to complete certain tasks, such as maintaining a consistent balance. In addition to the muscular factors, some of the weakness attributed to post-stroke hemiplegia is caused by

neuronal factors, including brain tissue damage that affects the corticospinal and supraspinal motor pathways (Patten et al, 2004). Damage to these pathways reduces neural traffic, which in turn results in impairment of motor unit recruitment. This deficiency in motor neuron activation results in lower firing frequencies that aren't adequate to cause tetanic muscle contractions or maintain the patient's balance (Landau et al, 2002).

The U.S. currently has over 3.5 million stroke survivors with 600,000 new cases of stroke each year and an increase in stroke occurrence in individuals younger than 65. Stroke patients also constitute over half of all inpatient neurological hospital admissions. These rising numbers mean increasing costs to treat stroke patients: each year, stroke treatment costs the U.S. over \$30 billion in both healthcare and productivity (Patten et al, 2004). As these numbers continue to increase, there is a growing need to develop low-cost yet efficient stroke rehabilitation methods for the recovery of function in stroke survivors. A device allowing post-stroke patients to monitor their balance distribution will both satisfy this demand for updated rehabilitation while allowing the patients to take on a more independent role in their recovery process.

Stroke survivors commonly experience a loss of functional standing balance and asymmetric weight distribution. While standing, their hemiplegic lower limb typically supports less of the weight. A patient is considered to have functional standing balance if they can maintain a standing position in a static environment as well as when their balance is subjected to external disturbances (Barclay-Goddard et al, 2009). Currently, physiotherapists attempt to improve this functional standing balance in stroke survivors by prescribing exercises that will increase the weight that the hemiplegic limb supports. Recently, new kinds of treatment seek to assist rehabilitation through force platforms that provide the patient with visual feedback. To prove the validity of this treatment, a study conducted seven clinical trials to compare the progress of hemiplegic patients on the force platforms with that of patients completing traditional balance treatment (Barclay-Goddard et al, 2009). The study concluded that the force platform, like the balance exercises, will result in more even balance distribution. Such reasoning is the driving force behind our design.

### **Design Motivation and Criteria**

The aspect of her physical therapy we were tasked to focus on was developing a system to aid in her balance recovery. The source of this problem stems from the numbness stemming from damage to the corticospinal tract (Landau et al, 2004) that affects Ms. Rohl's entire left side. This prevents her from properly ascertaining how much weight she is placing on her left foot, and the uneasiness this produces makes it difficult for Ms. Rohl to stand or walk as freely as she would like to. Our goal is to create a device that would monitor her weight distribution on a fixed surface and then relay this information back to her through quick visual feedback. This device will reinforce the sensation Ms. Rohl feels when evenly placing her weight over both feet by providing instant feedback.

Since Ms. Rohl cannot look down at her feet without becoming more imbalanced, the device's feedback must be presented near eye level. Ideally, this feedback would be presented with a simple user interface. Additionally, portability is a key component of the device: the client hopes to improve her balance through frequent practice, so the device must be functional in all environments, including outside and in smaller spaces. This desire for frequent practice also necessitates that the device can be used briefly many times throughout the day and while multi-tasking. To accomplish this, the balance system should be durable, not subject to deterioration over repeated use, compact enough that it could readily be carried in a purse or tote bag, and require only simple setup.

In addition to being as compact as possible, the height of the device above the floor must be no greater than 2.5 cm. If the device was any taller, Ms. Rohl would have trouble stepping onto it. This was observed during our client meeting both when climbing onto both the Wii Balance Board and one of our team member's design notebooks proved difficult for her left foot. Ms. Rohl also identified that the device should weigh less than 1.4 kg since anything heavier than that would be impractical for transportation and difficult to put away once she was done using it. Due to limited use of her left hand, Ms. Rohl also specified that she must be able to lift the device using only one hand; this could be accomplished through making the device lightweight and/or by adding a handle. She also requested that the size of the final balance system be about the size of a notebook; this would make it both portable and easy to store. The device must also both support a person's weight and accommodate a shoulder-width stance. The team also hopes to optimize safety through the inclusion of no-slip surfaces and waterproofing.

In terms of preexisting devices, there are a number of similar devices currently in use clinically. However, none fulfill the client's needs: very few of the devices are portable since most are designed for a clinical setting. Of the few devices that claim some portability, the size and weight of these balance systems make them impractical for Ms. Rohl's situation or require the use of a TV (Navarro et al., 2012) which Ms. Rohl does not possess.

## **Initial Design Ideas**

### *Wii Balance Board*

We initially planned to implement the balance system using a Wii Balance Board (figure 1) that can provide instant balance feedback by monitoring four force transducers (figure 2) located in the corners of the board (Clark et al, 2005). The transducers measure the corner force by calculating ground reaction forces at that point and, when combined, provide an accurate analysis of center of pressure movement and force distribution (Raymakers et al, 2005). Wii Balance Boards have previously been used in research to examine balance discrepancies, so we

hoped to adapt the design to enable the board to fulfill Ms. Rohl's requests for portability and simple user interface(Clark et al, 2010).



Figure 1: Picture shows a Wii balance Board. Transducers in each corner measure forces across the board and accurately calculate the weight distribution across the device. In our design it will communicate with a microprocessor via bluetooth to relay the distribution.

In our first design alternative, rather than connecting the Wii Balance Board to a television screen or computer as is traditionally done, we planned to connect the board's force output to a microcontroller with Bluetooth capabilities. Using this wireless capacity, the data would be conveyed to the user through an LED strip programmed to display the degree of imbalance: while the user's balance was concentrated on either side, the LED lights on this side would turn on, with more lit LEDs indicating a greater degree of imbalance. When the user is balanced, the device indicates the force distribution by turning on the center LED light.

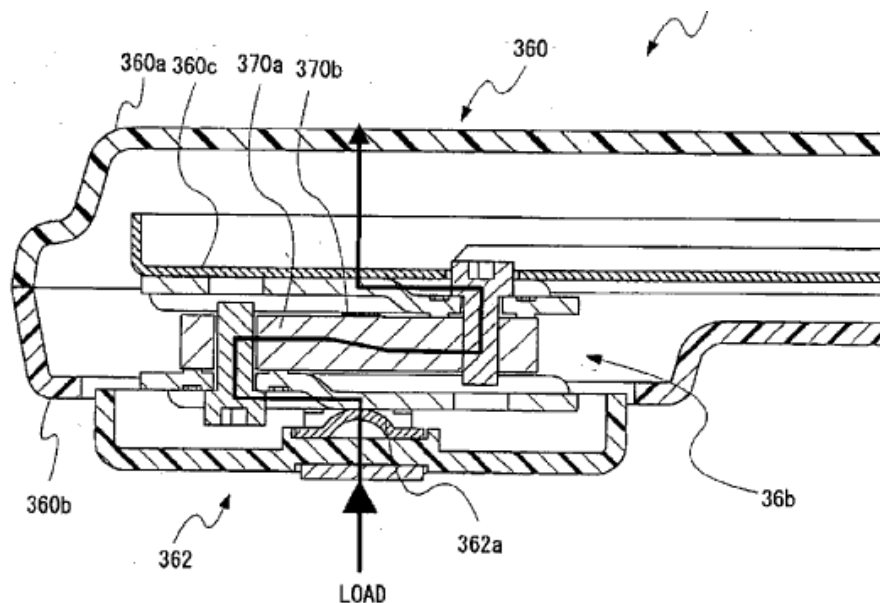

Figure. 2: The cross section of a Wii Balance Board, showing how a force transducer receives the force applied to the top of the board.

The Wii Balance Board is an extremely accurate method of measuring balance distribution; research has found it to be comparable to a laboratory-grade force platform (Clark et al, 2010). Compared to these force platforms currently in use, the Wii Balance Board is much less expensive: the board costs about \$100 dollars while other clinical balance systems can cost ten times that amount (Raymakers et al, 2005). However, we believed that a more cost-effective solution was possible, especially since a microcontroller with Bluetooth capacity would be expensive. Additionally, when we met with Ms. Rohl, she expressed concern that the Wii Balance Board, weighing 3.6 kg, was too heavy for her to realistically transport. This encouraged us to consider options that incorporate the Wii's reliability with increased portability and cost effectiveness.

### *Mechanical Balance*

The mechanical balance design consists of a teetering board atop a “W” shaped base (figure 3). Springs placed in the gaps between the two boards limit the degree of movement of the teetering platform. A telescoping pole, angling away from the board and user, attaches to a level at a height that's comfortable for the user to read. The angle of the pole amplifies the sensitivity of the level to the movements of the platform, giving more accurate feedback. If the user leans too far to either side, the level reacts accordingly.

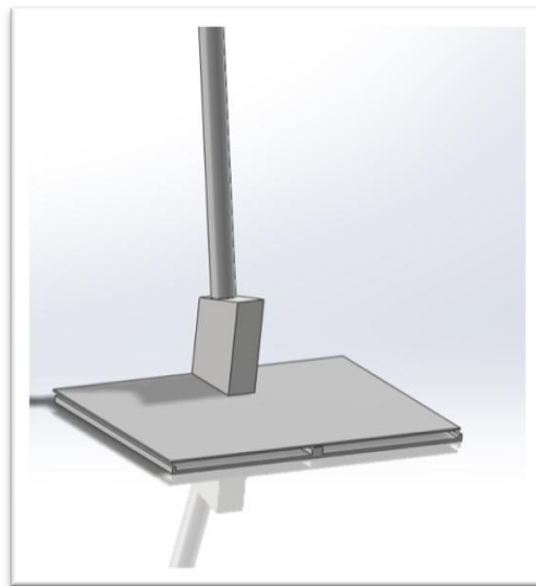

Figure 3: The mechanical balance operates by pivoting on the center column on a “W” shaped base. The outer walls limit the degree to which the platform can pivot. A pole attached to the platform magnifies the small angle the platform pivots, making the level easier to interpret.

It is apparent that this design is not very portable, so in an effort to remedy this, we planned to make the balance easy to disassemble and design its components to interlock. The telescoping

pole would be collapsible and could be locked onto the casing of the design. Also, the level would be removable and could be stored alongside the pole.

This design would be easy to fabricate because assembly requires a minimal amount of fabrication skill and time. In addition, the necessary materials are low cost and easily obtainable. Both the platform and the base would be made of wood. Springs and a level can be purchased at any hardware store, and the telescoping pole could be easily obtained through any third party internet supplier.

Although this alternative would be cheap and easy to fabricate, the mechanical balance system would not satisfy our most important design specifications. Since a level is not as easy to read as a digital display, the mechanical balance would be difficult for Ms. Rohl to interpret clearly. Also, the setup necessary to use the balance contributed to the low score for ease of use in the design matrix. This design requires the board to tip left and right slightly, which is a safety concern to Ms. Rohl who already struggles to keep her balance. Stepping onto the platform could be dangerous since, as Ms. Rohl informed us, her left foot is difficult to lift more than one inch off the ground. Lastly, despite our efforts, the balance would not be convenient for storage and would be difficult for our hemiplegic client to carry.

#### *Wheatstone Bridge Balance*

Our third option was a Wheatstone bridge balance. From the user's perspective, it functions the same as the Wii Balance Board. A mat unit is placed on the ground and the user stands on it; a display then indicates the user's relative weight distribution across either side of the mat. It would be small, light, and battery operated.

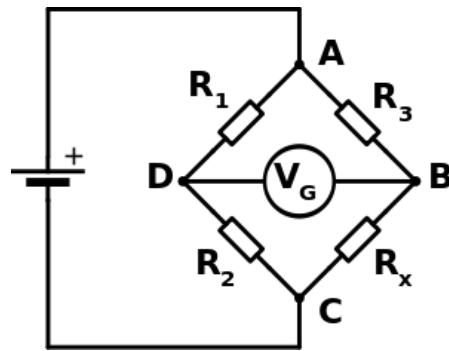

Figure 4: This is a wheatstone bridge, comprised of three parts; a power source, voltmeter ( $V_G$ ) and resistors ( $R_{1-3, x}$ ) in parallel. They are typically used to measure unknown resistance in devices ( $R_x$ ). We will use the same concept to measure voltage differences on either side of the circuit.

This design was entitled the Wheatstone bridge option because at its core, it is a simple Wheatstone bridge, which is an electrical circuit used to measure unknown electrical resistance. The circuit is comprised of three parts: a voltmeter, a power source (i.e., a battery), and a set of



resistors in parallel (figure 4). The voltmeter (or any device used to measure differences in potential) will register differences in voltage across either side of the parallel circuit (Northrup, 1912). This functionality provides us with the fundamental concept behind our design. If we can translate force from her foot into resistance, we will be able to use the output from the voltmeter to determine the distribution of weight.

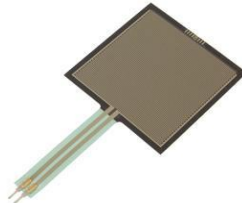

Figure5: A FSR or Force Sensitive Resistor comprised of two conductive surfaces separated by a semi-conductive matrix, as pressure is applied to the outer surface resistance across the device decreases. We will use them to gauge the force of her feet on either side of the board.

FSRs, or force sensitive resistors (figure 5), are resistors that have varying resistance based on the forces they are subjected to. Although there are many designs available, they operate on the same concept. Some material, consisting of conductive and nonconductive particles, separates two conductive surfaces. As pressure is applied to the surfaces, the conductive particles get closer, allowing for easier transfer of charge and reduction of resistance between the outer surfaces (Northrup, 1912). This functionality, when combined with a Wheatstone bridge, forms the technical background of our design. Since FSRs can accommodate forces beyond 4000 N and may be as thin as 0.5 mm, their inclusion in the device will allow it to be both versatile and portable.

The Wheatstone bridge balance design connects an FSR unit on each side of the parallel circuit such that each FSR receives pressure from one of the user's feet. As the resistance will vary proportionally to that force, the FSRs will change the voltage on each side, which will be monitored by the voltmeter and displayed as feedback to the user.

The two FSRs have a small area, so if a user were to step directly onto the sensor with nothing focusing the force, it is likely that they would miss the sensor and their weight would not be measured accurately. To solve this problem, we would focus her weight directly onto the FSR using two independent lever plates (figure 6). The rest of the device would consist of housing for the two plates and circuit wiring.

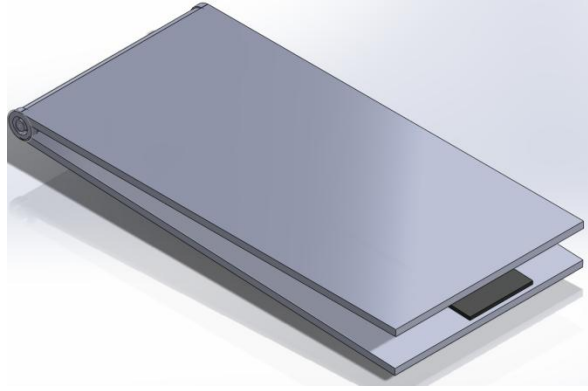

Figure 6: Our design uses two of these lever plates to direct the force from her feet directly onto the FSRs. These form the majority of the physical body of the device. An FSR is sandwiched between two Plates. Ensuring the FSR receives the full force from the users foot.

To achieve optimal portability and ease of use, this design would fold and be housed within a non-slip rubber mat or latex pad. This would make the design waterproof while maintaining a low profile and allowing it to fold in the middle. Regarding materials, the plates would be constructed from some type of metal while the FSRs must be able to withstand repeated loading for extended periods.

The greatest advantage to this design alternative is the compactness of the circuitry, which enables us to fit the Wheatstone bridge inside a small space. The lever plates can be less than a centimeter thick, so the design would be extremely lightweight and portable. However, we would need to consider that FSRs require constant recalibration, since the FSR unit may not consistently return to its original resistance after a load is applied. The addition of a microprocessor can solve this recalibration issue, though that will contribute to increased cost and difficulty of implementation.

### *Feedback Displays*

Feedback is crucial to our project, because Ms. Rohl wants to use our device to train herself to recognize her weight distribution. In order to do so, our design must be capable of conveying her current distribution and how to correct it in a clear and efficient manner. The display will be the only method of communicating that information. The display must be clear, easy to understand and accurate. We considered several feedback options during our design brainstorming that would satisfy our client's criteria: the voltmeter dial, an LED strip, a digital display, and audio feedback.

The output of the Wheatstone bridge is a voltmeter. Because of this, the first natural option would be to use a voltmeter display as an output. Many common voltmeters use a dial to display positive and negative voltages. The main advantage of this display is that it is simple to implement and very accurate. However, because the dial is an analog option, it would be difficult

to incorporate a microprocessor, which is necessary for the calibration of the device. Another potential problem with this display is that it may be difficult to interpret. The dial would display the exact measurement from the voltmeter: if the relative weights fluctuate quickly, the dial could easily become confusing.

The second possibility we considered was an LED strip. The LEDs would light up in either direction away from the center depending on the magnitude of the voltage difference between the two sides of the circuit. This would be very intuitive and easy to read: because there are a set number of LEDs, there would be a natural histogram effect. Small fluctuations would not be displayed to the user, which means the information presented would be simple and easy to understand. However, this means the LED display would not be as accurate as the dial or numerical options.

The final display option we considered was a digital display. This display would give the user a numerical value detailing the exact weight distribution as a percentage. The benefit of this design is that the information is more precise than the other designs we considered. It is also very easy to interpret. However, we believe that this design will be difficult to read at a glance. This readout requires two separate numbers since it will display a percentage for each side of the device. This will confuse the user and make interpretation difficult, especially if the user just glances at the display.

We also considered auditory feedback. Ms. Rohl is a lifelong musician and we believe that music and sound will help reinforce the benefits from training with this device. However, she thinks audio might be an “annoyance.” We believe that it may be a useful feature, for scenarios where the visual display may be cumbersome. It is simple enough to implement that we may opt to include it as an optional feature that the user can turn on or off as they choose.

### Decision Matrix Analysis

Criteria	Wii Balance Board	Wheatstone Bridge	Mechanical Balance
<b>Ease of Use (20)</b>	13	17	5
<b>Portability (15)</b>	5	14	8
<b>Reliability (15)</b>	13	12	10
<b>Accuracy (10)</b>	10	6	6
<b>Feasibility (10)</b>	4	6	9
<b>Safety (10)</b>	5	9	4
<b>Size (10)</b>	5	9	2
<b>Aesthetics (5)</b>	5	4	2
<b>Cost (5)</b>	1	4	5
<b>Total (100)</b>	61	81	51

Figure 7: The Decision Matrix was used to compare our three potential designs and decide which we will implement during the remainder of the semester. Values are assigned to each quality and each design is scored out of that value.

Ease of use, portability, and reliability were the most important attributes, and received the highest values.

Ease of use was stressed as the most necessary functionality by our client of any conceived design. The mechanical option scored the lowest since the amount of time required for setup and disassembly was excessive and the overall perceived awkwardness of the design deemed it unfavorable. The Wii Balance Board was relatively easy to use in terms of practicality. However, unmodified, it requires a TV--which our client does not have. Also, Ms. Rohl showed difficulty stepping onto the Wii balance board, and both of these drawbacks hurt the design in this scoring of the matrix. Ultimately, the utility and adaptability of the Wheatstone bridge approach gave it the highest score in the ease of use, because it can be tailored to Ms. Rohl's needs.

Another vital aspect of the design was portability: Ms. Rohl travels frequently, and she wants the ability to bring this device along with her to stay consistent with her balance practice. The Wii Balance Board scored the lowest on this criterion as, when we presented one to our client in our meeting; it was difficult for her to carry. The notion of her needing to pick it up with one hand and carry it around with an accompanying notebook or feedback source was impractical. The mechanical option scored slightly higher as, in theory, it could be compacted, bundled together, and carried around to some degree. The inevitable bulk, however, still far exceeded the portability which we were striving for. The Wheatstone bridge option scored the highest as the portability for the potential implementation resulted in no real limitation to portability.

Reliability was the last of the key defining characteristics to our project; this category is important because our device needs to provide consistently reliable feedback to the user in order to effectively assist in balance recovery. In terms of reliability, the Wii Balance Board scored the highest as a number of reliable online projects already exist. The Wheatstone Bridge/FSR approach scored only slightly less than the Wii Balance Board after assuming that the problems of calibration and deterioration could be overcome. The mechanical balance was deemed too difficult in terms of user feedback as the level could not be calibrated to a specific baseline, and any distortion in the surface on which the device is placed would significantly skew the readings.

Aesthetics and cost received the lowest scores in the decision matrix as the functionality of the device was prioritized over appearance and we were not given a specific budget to follow. The Wii Balance Board is a consumer product, so the aesthetic quality is already ensured; however, as a consumer product, it is also priced with a certain profit margin in mind so the price exceeds what we would deem appropriate. The Wheatstone bridge was both cost effective and circuitry could easily be concealed to improve appearance, so the aesthetic potential was favorable. The mechanical balance option would be an eyesore, although cost effective, which is represented on our design matrix.

In terms of safety, the Wii Balance Board and the Mechanical Balance received lesser scores as their thickness would be dangerous for our client. Also, the mechanical balance would involve movement of the platform, leaving our client's balance at risk. The Wheatstone Bridge scored

highly in the safety category since it can be extremely thin (less than two cm), and no movement takes place.

Although accuracy is important, it was not rated as highly as some of the other categories. Since Ms. Rohl is only concerned with weight distribution, not specific weights, accuracy becomes less of a vital issue. As indicated previously, Wii Balance Boards are extremely accurate, and are commonly used in a rehabilitative setting to aid in balance monitoring. For this reason, the Wii Balance Board received a perfect score in our design matrix in this category. A Wheatstone bridge would give accurate feedback on distribution on either side of the circuit, but deterioration of the FSRs may cause less accurate results. The Mechanical Balance received a similar score because, although the level itself is an accurate test of distribution, an uneven surface would skew results.

<b>Criteria</b>	<b>Dial</b>	<b>LED Strip</b>	<b>Digital Display</b>
<b>Ease of Use (20)</b>	11	17	9
<b>Accuracy (15)</b>	13	10	14
<b>Feasibility (15)</b>	8	11	11
<b>Reliability (10)</b>	7	9	9
<b>Cost (5)</b>	4	3	2
<b>Aesthetics (5)</b>	3	4	3
<b>Total (70)</b>	46	54	48

Figure 8: This display decision matrix compares the three different outputs we considered. Like the design decision matrix we valued Ease of Use as the most important quality.

When we analyzed our feedback options, we identified ease of use as the most important criterion, followed by accuracy and feasibility. Though the LED strip didn't score as well on accuracy since that method is based on a qualitative representation of the balance feedback, and LED strip is the easiest option for a user to interpret. The LED strip scored similarly to the digital display in both the reliability and feasibility categories while also receiving the highest score in the aesthetics category. These factors led us to conclude that the LED strip was the best feedback option (figure 8).

### **Comparison of Mid-Semester Design and Final Design**

At mid-semester, we had intended to pursue the fabrication of a Wheatstone bridge to measure the force distribution on our design platform. With an FSR on either side of the parallel circuit, the bridge would have given us the desired functionality of measuring voltage difference between the left and right sides of the circuit. The voltmeter at the center of the circuit would then provide the feedback for the output display.

However, because we decided to use a microcontroller to communicate between the resistors and the output, we realized that the use of a Wheatstone bridge was not necessary for the device to function. Instead, the circuit consists of 4 resistors in series with each of the two FSRs. This circuit is then connected directly to the microcontroller, meaning no voltmeter is used in the design. The difference between the voltages in the two resistors is measured and interpreted directly by the microcontroller.

The hinged platform concept remained in our final design, with small changes to help translate the force from the user onto the two FSRs. The folding plates alone would be insufficient to symmetrically focus the pressure of the top platform onto the FSR. To correct this, we implemented a small nub bonded to each FSR. The nub was made from a ¼” nylon thumb screw, with the threading removed and filed down so only the head remained. The area of the screw head matches the area of the FSR, as well as providing a flat and consistent surface for the top platform to contact.

However, having the nub under the platform caused an uneven surface for the user to stand on, making balancing atop the platform more difficult. To level the device, we inserted a second nub opposite the FSR across the user’s foot on each half of the platform, bonded directly to the polycarbonate. This created an even surface for the user to step on and also minimized the contact points between the upper and lower platforms.

Rather than constructing the plates from a type of metal, the platform is made from polycarbonate, meaning the base is more lightweight. Additionally, we decided not to encase the platform in a rubber mat, instead having the user stand directly on the plates.

## **Sensors**

For our final design, we implemented two FSRs, the FlexiForce® PS-03, manufactured by Images SI Inc. These FSRs consist of a long flexible body (8”/203mm by .55”/14mm) and a circular sensor with a 10 mm diameter embedded at one end. We decided to use these FSRs after examining their functionality and durability. Firstly, the weight curve was linear over the range of 0 to 100 lbs (figure 9), which matched the range measured in our design. Even though the upper bound of this range is 100 lbs, in order for 100 lbs to be delivered to a single FSR, our client would need to be impractically imbalanced. We would later confirm the FSRs’ linear relationship experimentally with testing. In addition, another one of our primary concerns was the longevity of the FSRs. We wanted to be confident that the integrity of the FSRs would not begin to degrade relatively soon into the design’s lifetime through improper implementation or excessive use. Images SI Inc. advertised that the FlexiForce® FSRs were tested by being subjected to 50 lb. loads for 1,000,000 hits/cycles between two pieces of metal. Upon completion

of said tests, the FSRs' output still responded with applied forces, so we expected the FSRs' performance to remain consistent.

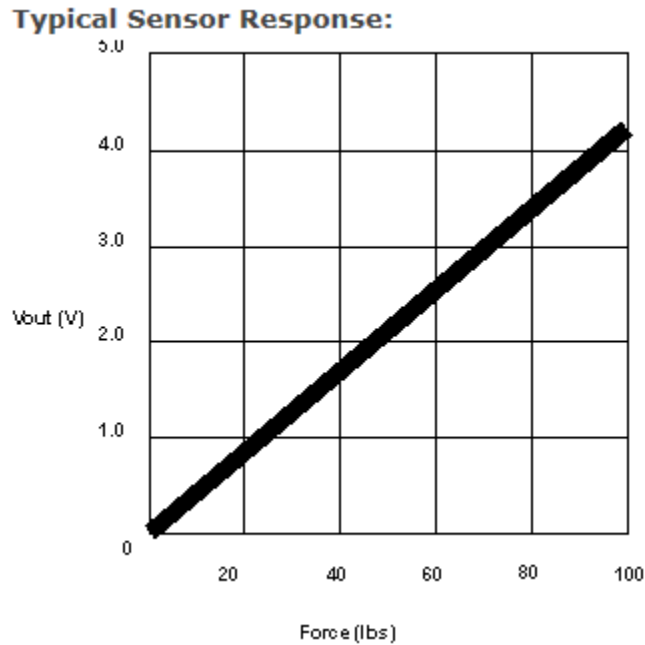

Figure 9: The FSR relationship of voltage vs. force for the FlexiForce resistors.  
Source: <http://www.imagesco.com/catalog/sensors/pressure-info.html>

## Platform

The platform for the balance device is constructed from four pieces of polycarbonate, each piece  $\frac{1}{4}$ " thick, X" wide, and Y" long. The pieces are arranged into two layers, each layer comprised of two sheets. The four pieces are connected by three 2.5 in. hinges: one hinge connects the two plates of the top layer, while the remaining two hinges connect the top and bottom layers of the left and right plates (figure 10). The plate arrangement creates a separate plate for each of our client's feet, and thus allows us to isolate the forces that each foot contributes for the FSRs to compare.



Figure 10: The arrow above points to the hinge connecting the top and bottom layers of the plate.

The two FSRs are placed 2 in. from the center of the bottom plate with heavy-duty double-stick tape. This placement results in the calculation of two separate forces on each side of the balance platform. To ensure that these forces are measured similarly, we created a ¼” thick nub from a piece of plastic with the same area as the force-sensing area of the FSR. This nub was attached to each FSR with epoxy. The addition of the nub means that each FSR will receive force delivered over the same surface area, so the only determinant of the FSR’s reading is the magnitude of the force itself, not the area of contact.

In order to add extra stability to the platform after the addition of the nubs over the FSRs, we made an extra nub of identical size and material for each side of the base. These nubs were attached with epoxy in a similar fashion to the outer edge of the plates. The inclusion of the additional nubs decreased the bending moment of the plates when a force was applied (figure 11). With this moment minimized, the platform is more stable and safety is increased for our client. The two nubs create a slight angle between the plates so that all applied force is directed to the nubs rather than the bottom plate. However, this angle is of minimal magnitude and does not affect use of the board.

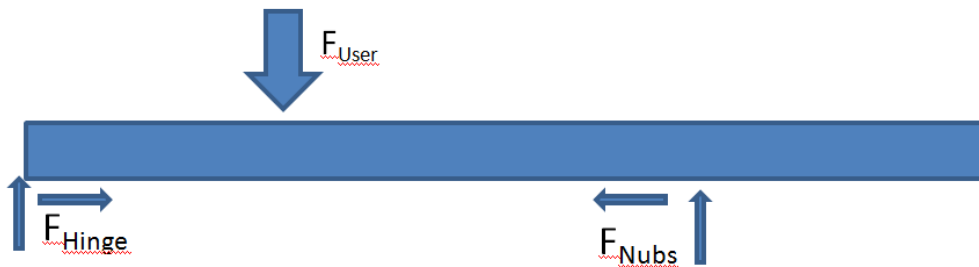

Figure 11a: Free body diagram of the plate with the use of nubs. When a force is applied to the plate, the nubs and hinge supply the opposing force to remain in equilibrium.



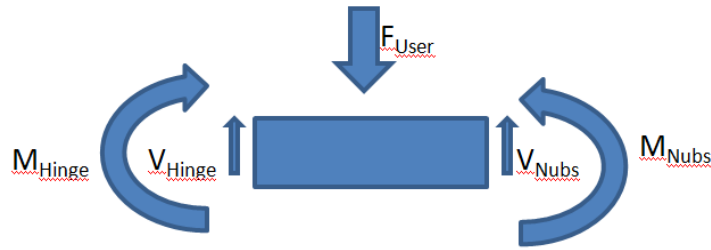

Figure 11b: Free body diagram of a cross section of the plate without the use of nubs. A bending moment is supplied, decreasing the stability of the plate.

Though all of the applied force is directed to the nubs, we needed to ascertain that the same proportion of the force was measured by the nub above the FSR on each side of the platform. The magnitude of this force is impacted by foot placement on the board; for example, if the right foot was placed close to the center of board while the left foot was aligned closer to the outer edge of the board, the left FSR would measure less force, even if the user was perfectly balanced. To measure accurate forces on each side, we needed to implement a method of consistently symmetric foot placement; however, our team found through early experimentation of the completed prototype that foot alignment was in fact relatively intuitive and was not as significant as initially expected.

Another piece of polycarbonate is screwed into the bottom layer of the platform and sealed with epoxy to insert into the box containing the circuit and microcontroller. Since this component is attached to the bottom layer, it won't affect the measurement of the FSR on that side, which is only influenced by the force acting on the nubs. The wires of the FSRs are threaded through the space in between the places back to the microcontroller box.

A handle connects the left and right side of the platform with Velcro. This arrangement allows our client to fold the platform after use, attach the handle, and carry, all while using only one hand. This fulfills her criteria for both portability and one-handed setup. The completed platform (figure 12) measures 1 in. high, 17 ¼ in. wide, 13 ⅞ in. long, and weighs just under 6 lb.

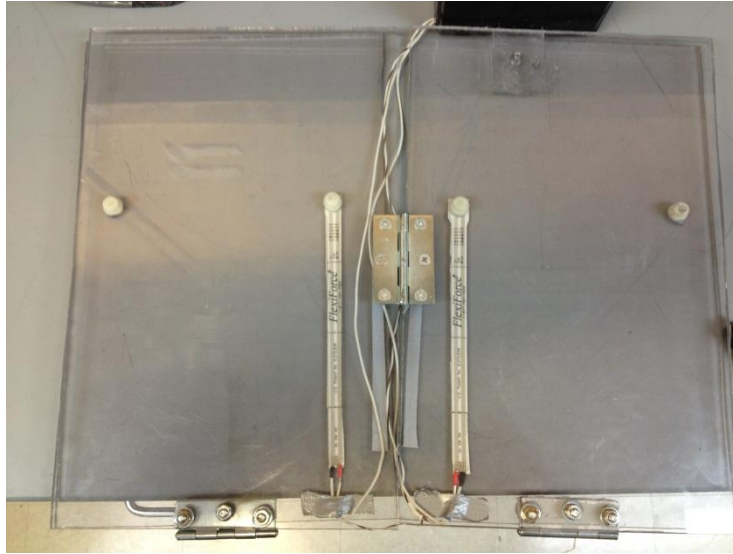

Figure 12: The completed platform, featuring hinged plates with two FSRs to measure force.

## Microcontroller

We needed a microcontroller that could support an LED display, which requires some computation as well as at least 9 output pins. The microcontroller also needed to be capable of interpreting the change in resistance of the FSRs. While the majority of microcontrollers have these capabilities, Arduino microcontrollers stood out because most models have the required capabilities, they are competitively priced and exceedingly popular, and our team has had some experience with them in the past. After comparing several Arduino models, we ultimately settled on the Arduino Leonardo since it was cost effective, and satisfied all of our functionality needs

The Leonardo has 13 digital output pins as well as 5 analog pins which can be used as input or output. The board has one ten-bit Analog to Digital Converter (ADC) multiplexed to the 5 analog pins. (“8-bit AVR Microcontroller with 16/32K Datasheet) The ADC can accept a maximum of 5 volts and converts it to a digital integer value between 0 and 1023. Because the ADC is multiplexed between 5 pins, it is impossible to read more than one pin simultaneously. Fortunately, the ADC only requires a few milliseconds to settle before making another reading. This is important because we need to monitor two different sensors almost constantly where the settle time is negligible. As a reference, it takes visual signals 20 – 40 milliseconds to reach the brain, while the ADC requires less than 10 milliseconds to settle. Other important features of the Leonardo are a 5 volt pin as well as several grounded pins; these are used by our circuit. The Leonardo is based off an ATmega32u4 processor and is self-contained. It is powered by connecting a 9 volt battery.

## Circuit

The microprocessor's ADC has the ability to convert voltage into a binary value for use by a program. However, in order to use that function to measure the changes in resistance, we first needed a circuit that delivers a voltage to the analog pin dependent on the resistance of the FSR. In order to do this we connected the +5V pin to both FSRs, then connected the FSRs to two separate analog pins and ground through four kohms of pull down resistance (figure 13). This circuit allowed us to measure the voltage of the FSR, and was dependent solely on the resistance of the FSRs.

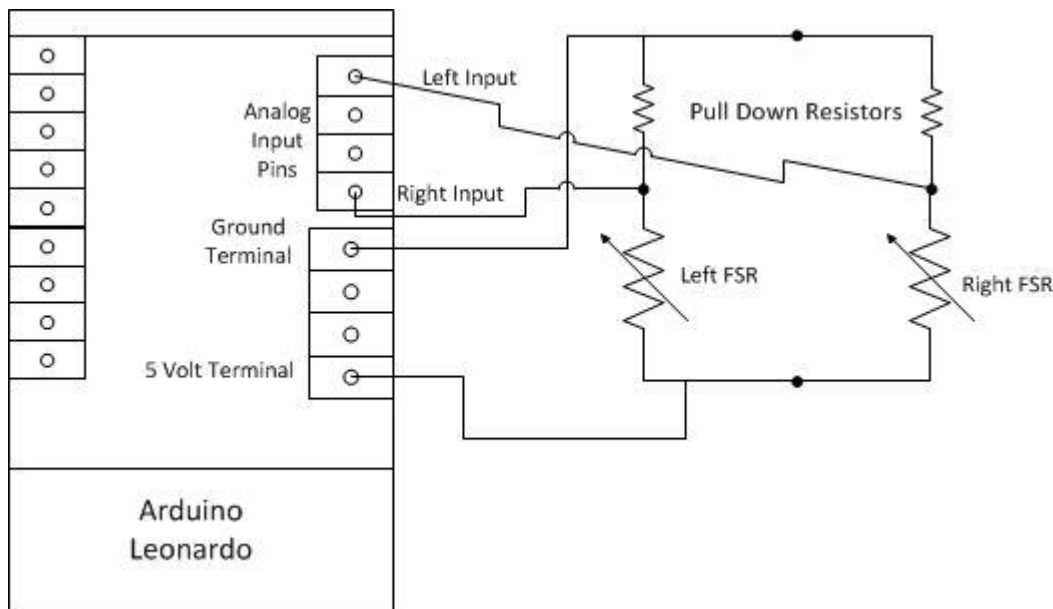

Figure 13: The circuit of the device, modeling the FSRs connected to +5V and analog pins.

## Programming

The basic structure of the Arduino program is a setup function which is called once when the Arduino is turned on, then a loop function is repeatedly called until the board is shut off. Our program has three fundamental components, none of which are used in the setup. The loop function first measures the voltages from each sensor, the second step is to calibrate the readings and compare them to determine their relationship. The final step is to display that relationship to the user via the LEDs. To measure the voltages, the `analogRead()` function is called to read the voltage from the analog pins.

Upon speaking with a doctor of physical therapy, we were directed to give a sizeable range for each LED, since the client would not maintain a steady weight on the platform. Also, he suggested the accepted range for a “balanced” individual be given a slightly higher degree of

freedom since it is very difficult for even a healthy individual to consistently stand with even weight distribution.

To calibrate the readings, we needed to develop a linear voltage vs. force graph for each resistor. During this calibration phase in our program, we compared the values read to the values we measured during testing. The linear best fit curve was used to normalize the force seen by each FSR. After the forces had been normalized, we then compared them to find the percent difference (see appendix). We found that the left FSR always had a much higher value than the right FSR, which was throwing off our comparison by approximately 100 - 200.

The final step in our program is to display relation to the user. We decided to display the user's current weight distribution. For example, if the user was leaning far right, all the LEDs on the right would light up. As the user becomes more balanced, the LEDs would turn off until only the center LED was lit. In every loop of the code, all of the LEDs are turned off before the correct LEDs are turned on; however, this happens much faster than the human eye can follow, and it appears that the correct LEDs are always lit. (See appendix for code.)

### **Output and LEDs**

The output of our device (figure 14) consists of a series of 9 LEDs attached to a small plastic box (3x2x1"). The three center LEDs are green, to indicate close to a fully balanced posture. Next, two yellow LEDs on either side would indicate a slightly off center posture, and the two red LEDs at the ends would correspond to most or all of the user's weight being centralized on one platform. Each hole for the LEDs was drilled so the LEDs would be flush with each other upon completion. The LEDs were aligned in a straight row, with the center LED slightly offline to ensure each LED could fit in the enclosure. The individual LEDs were glued to the plastic enclosure to guarantee the connections between the LEDs and the wires within the box remained secure.

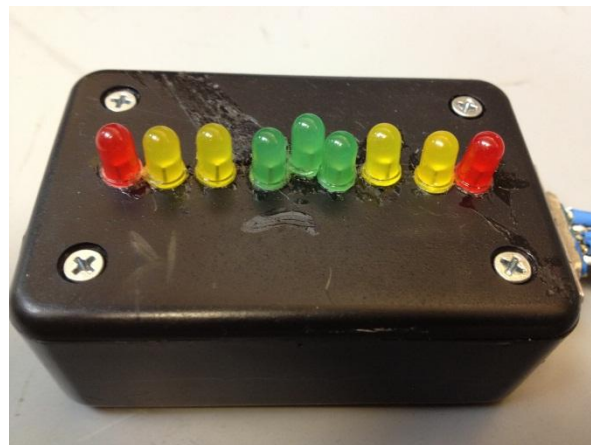

Figure 13: The output box has 9 LEDs to indicate the user's balance distribution.

Also attached to the exterior of the box is a female VGA port with 15 input pins. This port is used to attach the LEDs to the microcontroller by using a modified male-male VGA cable. The cable consists of 10 solid-core wires braided together, with male VGA ports on either end. Inside the plastic enclosure, the positive end of each LED is connected to a wire from the LED to one of the 15 D-Sub connector inputs that are paired with the VGA ports. The connections between the wire and the LED, as well as the wire and the D-Sub connector are soldered to maintain a connection through movement and storage of the device. The negative end of each LED is soldered to a negative rail within the box to ground the output circuit.

## **Testing**

We conducted three tests over the course of our design development. First, we did preliminary testing on the FSRs when they arrived simply to ensure they worked as expected. The next two tests were to refine the code in the microprocessor; one test was to determine the voltage vs. force graphs for the FSRs once they were in the platform. The final test was to calibrate the LEDs after the platform was completed.

The preliminary FSR test was fairly simple. We used the ohmmeter function of a multimeter and observed the change in resistance as we applied subjective forces. The objective of this test was to ensure that as pressure was applied to the FSR, the resistance would go down in a repeatable, stable way. We observed that behavior in both FSRs, proving that the FSRs would work as we predicted.

We used a weight set from the COE student shop with weights ranging from one hundred grams to one kilogram. We found that as forces increased, the FSR's resistance decreased. However, for weights less than one kilogram, testing was inaccurate and unstable. Weights over one kilogram gave reliable enough results to draw decisive conclusions regarding the force-resistance relationship, even for small changes in weight (+/- 100 grams).

Once the FSRs were in place on the platform we could develop the actual voltage vs. force graphs in our second test. We had to wait until the FSRs were fixed to the base because details like electrical connections and the location of the supports could potentially induce changes in resistance we see when we add weight. The voltage vs. force graph (figure 14) allows us to calibrate the readings from the two different FSRs. Since there was a slight difference in the voltage vs. force relationship of each FSR, the code must be programmed to account for it accordingly.

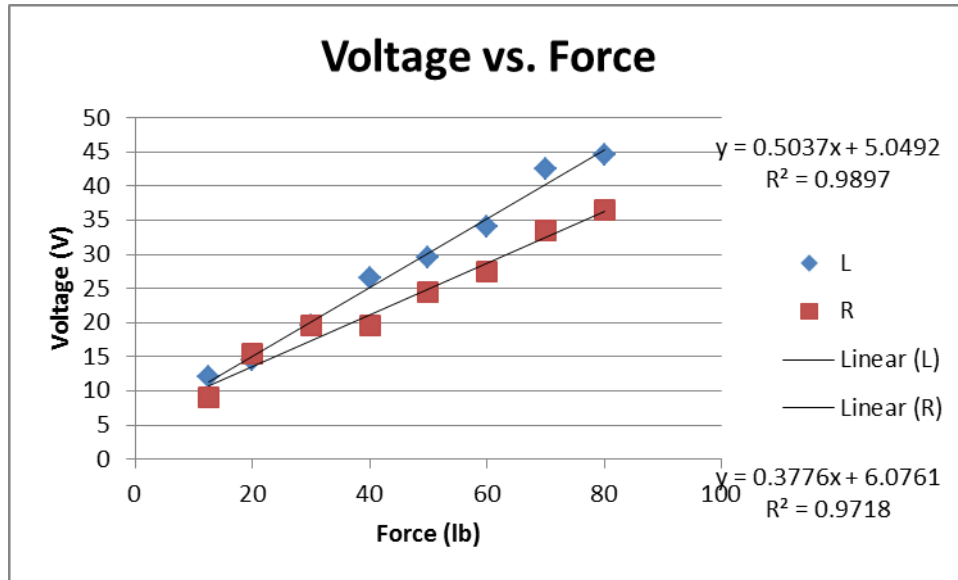

Figure 14: The relationship between force and voltage for each FSR allowed us to normalize the forces and relate them to each other in the code.

The methodology of this test was to isolate each plate (figure 15) and add weight to it. We had to be careful to put the center of the dumbbell in the same place for each trial or the force would have been distributed differently each run and our results would have been inaccurate. Using the same circuit as in our device, we were able to measure the voltage by testing a range of forces; however, rather than connecting the microcontroller to the LED output, we used a program that read the quantitative voltage measurements (see appendix). We manually entered the results into Microsoft Excel, which produced our voltage vs. force graphs.

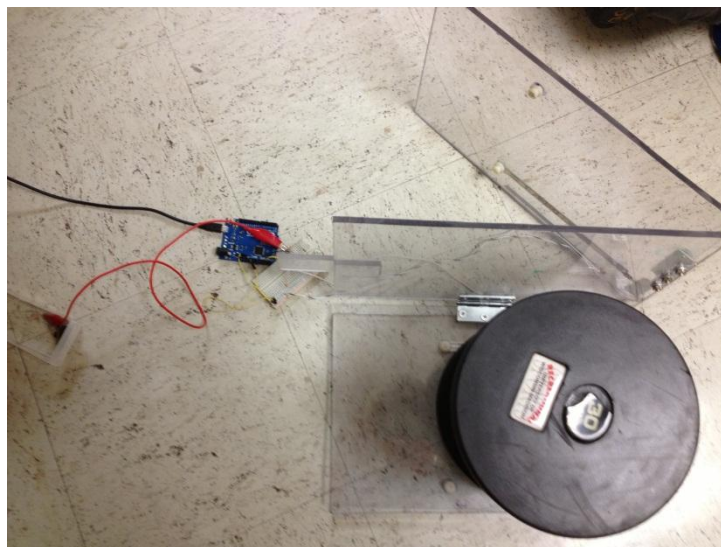

Figure 15: By folding one of the plates out of the way and setting a dumbbell on the other plate, we were able to isolate the response of each FSR to applied force.

By applying a linear fit to both data sets, we found that both graphs produced closest fit lines with  $R^2$  values over .975, a statistically significant correlation. We were able to use these graphs to calibrate our measurements in relation to each other. We also concluded from this test that placement is a very important factor, and we must put something in place to guide Carol's feet into a consistent location every time.

## Budget

At the onset of the semester, our team was not given a specific budget by our client. Hoping to minimize the costs as much as possible, we intended to develop our prototype for less than \$150. We successfully stayed under-budget, since we would spent roughly \$50 each on the FSRs, microprocessor, and other miscellaneous housing materials. We were able to find a sufficient and cost effective microprocessor that met our needs for \$28.59. However, the FSRs that best suited our design requirements and were within our price range were slightly more expensive than expected, costing us about \$70 once shipping costs were factored in. For the remainder of the project's expenses we were able to remain on our expected \$50 estimate for the platform, feedback, and Arduino housing (figure 16). This was largely due to a donation of our platform's polycarbonate from Sabic *Innovative Plastics*.

Arduino Microprocessor	\$24.95
FlexiForce FSR (2)	\$76.05
Project Enclosures (2)	\$8.98
Assorted LEDs	\$8.38
Polycarbonate Sheet	\$0
Hardware, Circuit Components	\$31

Figure 16: The above table explains the money spent on each component of the design. The total amounted to less than \$150.

## Future Work

One of our greatest challenges was determining the placement of the FSRs and feet so both sides represented a similar force distribution. Though we eventually achieved an efficient solution to this problem, we believe that we could refine the force sensing system to minimize the importance of foot placement and make the prototype more user-friendly. The possibility of adding some manner of foot guide or placement indicator is also another consideration that could prove useful in further testing or in another iteration of the device. Related to improving the ease of use, with future work, we would like to expand the possible range of users by calibrating the

device using a larger range of weights and expanding the base to accommodate a greater stance. As we investigate increasing the width of the device, future work could lead to minimizing the other dimensions of the design. We'd like to find ways to decrease the height of the platform so our client wouldn't need to worry about stepping onto the platform, however minimal the step may be. This height minimization would also lend itself to a decrease in the weight and subsequent improved portability. Other future work includes exploring the options for more in-depth feedback regarding weight distribution, such as providing the user with numerical feedback in addition to the qualitative feedback provided via the LEDs. Finally, we would like to consider the possibility of supplemental features, such as audio feedback and Bluetooth connectivity.

## **Conclusion**

We have been tasked with designing a device to assist our client in improving her weight distribution and balance through visual feedback. We considered three design alternatives: a repurposed Wii Balance Board, a mechanical balance, and a Wheatstone bridge balance. After analyzing our options, we decided to implement the Wheatstone bridge balance. However, throughout the second half of the semester, our design evolved beyond what we had originally planned. Rather than implementing a Wheatstone bridge circuit, we decided to include a simplified circuit for each FSR, consisting of a series of resistors. We also updated the plate design, now taking advantage of the slight angle produced by the hinges by placing a nub over each FSR to direct the force over a consistent area. Using a modified VGA cable, we connected the circuit and microcontroller to LED output that conveyed the user's degree of imbalance.

We tested the FSRs by measuring the voltage applied to each when subjected to 12.5-100 lb. By applying a linear fit to this data, we related the forces measured by the two FSRs to obtain an accurate reading of balance distribution. The finished device fulfills our client's requirements by providing instant balance feedback while optimizing portability, ease of use, and affordability.

Since strokes affect a growing number of individuals each year, stroke rehabilitation has an ever-increasing importance. As more individuals suffer strokes, more health care money is dedicated to rehabilitation costs. This calls for a cost-effective device to aid rehabilitation of these patients. With further work, we believe our weight distribution device could be adapted for a greater of spectrum of poststroke patients and included in a rehabilitation approach that allows affected individuals to independently monitor their recovery progress.



## Appendix

### *Arduino Code*

```
//pin variables
//these are the LEDs
int l = 8;
int l3 = 0;
int l2 = 7;
int l1 = 6;
int M = 5;
int r1 = 4;
int r2 = 3;
int r3 = 2;
int r = 1;

//these are the analog inputs
int inL = A5;
int inR = A0;

// holding variables
//used to measure the voltage from the circuit and for computation
int lVal;
int rVal;

//calibration variables
//Left plate
double lX; //this is used to hold the approximate force seen by
the FSR
double lB = 5.0492; //this is the y-intercept from our calibration graphs
double lM = .5037; // this is the slope from our calibration graph.

//Right plate
double rX; //same as above but for the right plate
double rB = 6.076;
double rM = .3776;

//difference variables
double comparison; //used to compare the two forces
double comparConst; //used to calibrate the comparison variable

//boundaries
double maxBndry = 1.65; //these define the boundaries between different LEDs
double bndry3 = 1.45;
double bndry2 = .9;
double minBndry = .35;

//////////BEGIN SETUP//////////
void setup() {
  pinMode(l, OUTPUT);
  pinMode(l3, OUTPUT);
  pinMode(l2, OUTPUT);
  pinMode(l1, OUTPUT);
  pinMode(M, OUTPUT);
```

```

pinMode(r1, OUTPUT);
pinMode(r2, OUTPUT);
pinMode(r3, OUTPUT);
pinMode(r, OUTPUT);

Serial.begin(9600);
ledTest();

delay(100);
lVal = analogRead(inL);
delay(10); //resting time for the ADC
rVal = analogRead(inR);

lX = (lVal - lB)/lM;
rX = (rVal - rB)/rM;

comparConst = (lX - rX)/((lX + rX) / 2); //value when no force is applied.

digitalWrite(M, HIGH); //signals the device is ready for use
delay(300);
digitalWrite(M, LOW);
}
//////////END OF SETUP//////////

void loop() {
//////////
//read in values
//////////

lVal = analogRead(inL);
delay(10); //settling time for the ADC
rVal = analogRead(inR);

//////////
//compare values
//////////
lX = (lVal - lB)/lM;
rX = (rVal - rB)/rM;

comparison = (lX - rX)/((lX + rX) / 2 - comparConst);
//compares voltage of left and right, subtracts value of zero force

//////////
//display
//////////
clearAll();
displayLEDs(comparison);

//////////
//Debugging
//////////
/*
Serial.print(lVal);
Serial.print(" ");
Serial.print(lX);
Serial.print(" ");

```

```

Serial.print(comparison);
Serial.print(" ");
Serial.print(rX);
Serial.print(" ");
Serial.print(rVal);
Serial.print(" ");
Serial.println(comparConst);
*/
////////////////////END OF MAIN////////////////////
delay(100);
}

////////////////////ADDITIONAL FUNCTIONS////////////////////

/*
*displayLEDs computes what LEDs to display and displays them.
*returns void
*/
void displayLEDs(double comparison){
if(comparison > maxBndry){
    turnOn(l, l3, l2, l1);
}
else if(comparison > bndry3) {
    turnOn(l3,l2,l1);
}
else if(comparison > bndry2) {
    turnOn(l2,l1);
}
else if(comparison > minBndry) {
    turnOn(l1);
}
else if(comparison > -minBndry) {
    turnOn(M);
}
else if(comparison > -bndry2) {
    turnOn(r1);
}
else if(comparison > -bndry3) {
    turnOn(r1,r2);
}
else if(comparison > -maxBndry) {
    turnOn(r1,r2,r3);
}
else{
    turnOn(r1,r2,r3,r);
}
}

/*
*clearAll turns all LEDs off.
*/
void clearAll(){
digitalWrite(l, LOW);
digitalWrite(l3, LOW);
digitalWrite(l2, LOW);
digitalWrite(l1, LOW);

```

```

digitalWrite(M, LOW);
digitalWrite(r1, LOW);
digitalWrite(r2, LOW);
digitalWrite(r3, LOW);
digitalWrite(r, LOW);
}

/*
*turnOn turns up to four LEDs at once.
* there are four versions of this function passed one to four LEDs.
*/
void turnOn(int a, int b, int c, int d){
    digitalWrite(a, HIGH);
    digitalWrite(b, HIGH);
    digitalWrite(c, HIGH);
    digitalWrite(d, HIGH);
}

/*
*turnOn turns up to four LEDs at once.
* there are four versions of this function passed one to four LEDs.
*/
void turnOn(int a, int b, int c){
    digitalWrite(a, HIGH);
    digitalWrite(b, HIGH);
    digitalWrite(c, HIGH);
}

/*
*turnOn turns up to four LEDs at once.
* there are four versions of this function passed one to four LEDs.
*/
void turnOn(int a, int b){
    digitalWrite(a, HIGH);
    digitalWrite(b, HIGH);
}

/*
*turnOn turns up to four LEDs at once.
* there are four versions of this function passed one to four LEDs.
*/
void turnOn(int a){
    digitalWrite(a, HIGH);
}

/*
*ledTest displays each LED individually followed by a sychronized flash
through all of them.
*This is useful for determining any problems with the wiring of the LEDs.
*/
void ledTest(){
    delay(500);
    Serial.println("Begin test");
    digitalWrite(1, HIGH);
    delay(100);
    digitalWrite(1, LOW);
    digitalWrite(13, HIGH);
}

```

```
delay(100);
digitalWrite(l3, LOW);
digitalWrite(l2, HIGH);
delay(100);
digitalWrite(l2, LOW);
digitalWrite(l1, HIGH);
delay(100);
digitalWrite(l1, LOW);
digitalWrite(M, HIGH);
delay(100);
digitalWrite(M, LOW);
digitalWrite(r1, HIGH);
delay(100);
digitalWrite(r1, LOW);
digitalWrite(r2, HIGH);
delay(100);
digitalWrite(r2, LOW);
digitalWrite(r3, HIGH);
delay(100);
digitalWrite(r3, LOW);
digitalWrite(r, HIGH);
delay(100);
digitalWrite(r, LOW);
delay(100);
digitalWrite(l1, HIGH);
digitalWrite(l3, HIGH);
digitalWrite(l2, HIGH);
digitalWrite(l1, HIGH);
digitalWrite(M, HIGH);
digitalWrite(r1, HIGH);
digitalWrite(r2, HIGH);
digitalWrite(r3, HIGH);
digitalWrite(r, HIGH);
delay(300);
clearAll();
delay(500);
Serial.println("End of LED Test");
}
```

## References

Patten et al. "Weakness and strength training in persons with poststroke hemiplegia: Rationale, method, and efficacy." *Journal of Rehabilitation Research and Development* May/June 2004: 293-312.

Landau et al. "Preservation of directly stimulated muscle strength in hemiplegia due to stroke." *Archives of Neurology* Volume 59, Sep. 2002: 1453-1457.

Barclay-Goddard et al. "Force platform feedback for standing balance training after stroke." *The Cochrane Library* 2009.

Navarro et al. "Balance recovery through virtual stepping exercises using Kinect skeleton tracking: a follow-up study with stroke patients." *Studies in Health Technology and Informatics* 2012 Volume 181.

Clark et al. "Validity and reliability of the Nintendo Wii Balance Board for assessment of standing balance." *Gait and Posture* 2010: 307-310.

Raymakers et al. "The assessment of body sway and the choice of stability parameter(s)." *Gait and Posture* 2005: 48-58.

Northrup, Edwin F. *Methods of Measuring Electrical Resistance*,. New York: McGraw-Hill Book, 1912. Print.

8-bit AVR Microcontroller with 16/32 Bytes of ISP Flash and USB Controller Datasheet. Atmel.