

BME Design-Spring 2026 - Team AFO

Complete Notebook

PDF Version generated by

KALOB KIMMEL

on

Apr 29, 2026 @05:43 PM CDT

Table of Contents

Project Information	2
Team contact Information	2
Project description	3
Team activities	4
Team Meetings	4
01/26/2026 - Team Meeting 1	4
02/02/2026 - Team Meeting 2	5
02/09/2026 - Team Meeting 3	6
02/16/2026 - Team Meeting 4	8
02/19/2026 - Team Meeting 5	9
02/25/2026 - Team Meeting 6 (in lecture)	10
03/02/2026 - Team Meeting 7	11
03/16/2026 - Team Meeting 8	13
03/23/2026 - Team Meeting 9	14
04/06/2026 - Team Meeting 10	15
04/13/2026 - Team Meeting 11	16
04/20/2026 - Final Team Meeting 12	17
Client Meetings	18
02/03/26 Client Meeting 1	18
Advisor Meetings	19
01/30/26 Advisor Meeting 1	19
02/06/26 Advisor Meeting 2	20
02/13/26 Advisor Meeting 3	22
03/06/26 Advisor Meeting 4	23
03/13/26 Advisor Meeting 5	24
04/10/26 Advisor Meeting 6	25
Design Process	26
02/06/2026 - PDS	26
02/12/2026 - Dorsiflexion Materials Design Matrix	27
02/19/2026 Updated Design Matrix	28
02/19/2026 Preliminary Presentation Slides	29
04/25/2026 - Final Poster	30
04/29/2026 - Final Report	31
Materials and Expenses	32
02/18/2026 - Materials Printing and Manufacturing	32
04/29/2026 - Final Expenses	33
Fabrication	34
3/10/2026 - AFO Fabrication	34
3/12/2026 - AFO Fabrication 2	36
03/23/2026 - Fabrication Plans	39
Testing and Results	40
Protocols	40
02/19/2026 - MTS Testing Protocol	40
04/06/2026 - Testing Protocol at UMich	41
Experimentation	42
02/19/2026 - MTS material testing	42

3/2/2026 - MTS Data Analysis	44
04/20/2026 - Dorsiflexion and Stabilogram Testing Analysis	52
Fall 2025 Project Files	53
Fall 2025 Notebook	53
Fall 2025 Final Report	55
Fall 2025 PDS	57
Alex Conover	59
Research Notes	59
Biology and Physiology	59
01/27/2026 - FSHD 1 Research	59
01/27/2026 - Gait Cycle Research	62
01/27/2026 - Materials Research	66
01/27/2026 - 3D Printing Research	68
02/10/2026 - Carbon Fiber Types and Responses	70
Competing Designs	72
01/27/2026 - Competing AFO Research	72
01/27/2026 - Standards Research	74
01/27/2026 - Patents Research	76
02/12/2026 - Materials Research	78
03/05/2026 - Patent Research, Dorsiflexion Specific	80
03/05/2026 - Patent Research, Medial/Lateral Specific	83
Design Ideas	85
02/02/2026 - Fall 2025 Reflection	85
02/02/2026 - Design Upgrade Ideas	87
02/03/2026 - PDS rework	89
02/10/2026 - Carbon Fiber Manufacturing	91
02/11/2026 - CF Lab Notes	93
03/05/2026 - Design Update Ideas	95
03/10/2026 - Fabrication 1	97
03/12/2026 - Fabrication 2	99
Training Documentation	101
01/27/2026 - Lab Training	101
02/05/2026 - Woodshop Training	102
03/29/2026 - Woodshop Certification	103
Lecture Notes	104
01/28/2026 - Library Session 1	104
02/04/2026 - Lecture 2 (JOBS)	106
02/11/2026 - Lecture 3 (interview)	108
02/18/2026 - Lecture 4 (Feedback)	110
02/25/2026 - Lecture 5 - Diversity and Inclusion	111
03/04/2026 - Lecture 6 - Library Lecture 2	114
03/06/2026 - Tong Lecture	118
03/11/2026 - Lecture 7 - Protocol Development	119
03/18/2026 - Lecture 8	121
03/25/2026 - Lecture 9	122
04/08/2026 - Lecture 10	124
04/15/2026 - Lecture 11	125
Reflections	127
02/27/2026 - Preliminary Reflection	127
03/12/2026 - Protocol Reflections	128
04/16/2026 - Data Collection	129
04/23/2026 - Elevator Pitch	130
04/24/2026 - Statistical Analysis	131
04/29/2026 - Final Thoughts	134
Avery Lyons	135
Research Notes	135
Biology and Physiology	135
01/26/26 Research Notes: Revolutionizing Medical 3D Printing: Filaflex for Orthotics, Podiatry, & Prosthetics"	135
01/26/26 Research Notes: "Materials and Manufacturing for Ankle-Foot Orthoses: A Review"	136
01/26/26 Research Notes: "Spatio-temporal gait differences in Facioscapulohumeral muscular dystrophy during single and dual task overground walking- A pilot study"	138

01/26/26 Research Notes: "Interplay between balance, gait kinematic and physical activity level in facioscapulohumeral muscular dystrophy"	140
01/31/26 Research Notes: "Characterization of carbon fiber reinforced PLA composites manufactured by fused deposition modeling"	141
02/03/26 Research Notes: "Carbon fiber properties"	142
02/09/26 Research Notes: "Eco-friendly 3D Printing Filament PLA CF Raw Materials"	144
02/11/26 Research Notes: "What is TPU Filament?"	145
02/11/26 Research Notes: Design Matrix Brainstorm	146
02/16/26 Research Notes: Comparing Material Properties of TPU, PET, and Nylon 66	147
02/16/26 Research Notes: University of Michigan possible connections	148
02/23/26 Research Notes: "What is Carbon Fibre?"	149
02/23/26 Research Notes: "Ultimate Guide to PLA-CF 3D Printing Filament"	151
02/25/26 Research Notes: "Energetics of Walking and Running"	152
Competing Designs	153
01/31/26 Reflection of Fall 2025 Design	153
03/04/26 Research Notes: Ankle Foot Orthosis Patent Search	154
03/04/26 Research Notes: Ankle Foot Orthosis Patent Search	156
03/04/26 Research Notes: Dorsiflexion Patent Search	158
Ethics	160
01/26/26 Research Notes: "Ethical framework of assistive devices: review and reflection"	160
02/01/26 Research Notes: "A Roadmap to Patient Engagement"	162
02/09/26 Research Notes: "A Guide to Patient Engagement: 7 Practical Strategies to Consider"	164
03/16/26 Brainstorming Notes: Collaboration Between Two Academia Institutions	166
Design Ideas	167
03/16/26 Research Notes: Final Product Finishes	167
Training Documentation	168
Training Documentation 2	168
Lecture Notes	169
01/28/26 Lecture 2 Notes: "Library Session 1: Article searching, source evaluation, and citation management"	169
02/04/26 Lecture 3 Notes: "Resume, Cover Letter, and Job Postings"	170
02/11/26 Lecture 4 Notes: Presentation Tips	171
02/18/26 Lecture 5 Notes: Presentation Peer Review	173
02/25/26 Lecture 6 Notes: Diversity and Inclusion in Design	174
03/04/26 Lecture 7 Notes: Library Session 2- Patents Standards, and Other Design Resources	176
03/09/26 Tong Lecture Notes	178
03/11/26 Lecture 8 Notes: Protocol Development	180
03/18/26 Lecture 9 Notes: Brevity in Communication	182
03/25/26 Lecture 10 Notes: Ethics in Engineering	184
04/08/26 Lecture 11 Notes: Engineering Judgement	185
04/15/26 Lecture 12 Notes: Poster Presentations	186
04/22/26 Lecture 13 Notes: Final Poster Feedback	188
Individual Work	189
03/10/26 Fabrication Notes	189
03/10/26 Protocol Notes	190
03/10/26 Preliminary Report Personal Feedback Notes	191
03/16/26 Fabrication Protocol Notes	192
03/25/26 Brainstorming Executive Summary	193
04/08/26 Executive Summary Draft Feedback Notes	195
04/15/26 Elevator Pitch Write-up	196
04/25/26 Final Report Work	197
Sierra Loosen	198
Research Notes	198
Biology and Physiology	198
1/28/26 Literature Search - Facioscapulohumeral Muscular Dystrophy	198
1/28/26 Literature Search - Ankle Foot Orthosis (AFO) stiffness design for mitigation of ankle inversion injury	199
1/28/26 Literature Search - Use, tolerability, benefits and side effects of orthotic devices in Charcot-Marie-Tooth disease	201
1/28/26 Literature Search - WHO standards for prosthetics and orthotics	203
Competing Designs	205
1/28/26 Reviewing Previous AFO Teams' Work	205
2/3/25 Literature Search-Costs of AFOs	207
2/3/26 Literature Search-Ankle Foot Orthosis (AFO) Market Report Overview	208
2/3/26 Literature Search-Effects of Carbon versus Plastic Ankle Foot Orthoses on Gait Outcomes and Energy Cost in Patients with Chronic Stroke	209
2/5/26 Literature Search - Mechanical Properties of Additively Manufactured Thermoplastic Polyurethane (TPU)	211

2/11/26 Literature Search-Ballistic Fabrics	216
2/11/26 Literature Search-Polyester-Elastane Blends	218
2/11/26 Literature Search-Thermoplastic Polyurethane	220
Design Ideas	222
2/11/26 Comparison of Design Matrix Materials	222
Training Documentation	224
3/5/26 Previous Semester's UW Training Documentation	224
3/5/26 Previous Semester's CITI Training Documentation	225
3/5/26 Previous Semester's D+I Lab Training Documentation	227
3/8/26 Spring 2026 Training-Bloodborne Pathogens	228
Lecture Notes	230
1/28/26 Lecture Notes - Library Session 1	230
2/4/26 Lecture Notes-Peer Resume Reviews	232
2/11/26 Lecture Notes-Presentation Tips and Job Interviews	233
2/18/26 Lecture Notes-Preliminary Presentation Peer Review	234
2/25/26 Lecture Notes & Team Activity-Diversity and Inclusion in Design	235
3/4/26 Lecture Notes-Library Session 2	237
3/6/26 Tong Lecture	239
3/11/26 Lecture Notes-Protocol Development	240
3/18/26 Lecture Notes-Brevity in Communication	242
3/25/26 Lecture Notes-Ethics in Engineering	244
4/8/26 Lecture Notes-Engineering Judgment	246
4/15/26 Lectures Notes-Poster Presentations	248
4/22/26 Lecture Notes-Peer Poster Review	249
BSAC	250
1/30/26 BSAC Meeting	250
2/6/26 BSAC Executive Meeting	251
2/13/26 BSAC Meeting with Faculty	252
2/20/26 BSAC Executive Meeting	253
2/27/26 BSAC Meeting	254
3/6/26 BSAC Executive Meeting	255
3/13/26 BSAC Meeting with Faculty	256
4/10/26 BSAC Meeting with Faculty	257
Individual Work	258
2/18/26 Individual Preliminary Presentation Work	258
2/19/26 Individual Preliminary Presentation Work	259
2/22/26 Individual Preliminary Report Work	260
2/24/26 Individual Preliminary Report Work	261
3/7/26 MTS Testing Analysis	262
3/10/26 Team AFO Fabrication	263
3/12/26 AFO Fabrication 2	264
3/12/26 Testing Protocol Brainstorming	265
3/17/26 Work on Fabrication Protocol	266
3/26/26 Executive Summary Brainstorming	267
3/26/26 Makeup Show and Tell Assignment	268
4/6/26 Individual Work on Executive Summary	270
4/15/26 Individual Work on Final Poster	271
4/16/26 UMich Data Analysis Work	272
4/21/26 Individual Final Deliverables Work	273
4/28/26 Individual Work on Final Report	274
Kalob Kimmel	275
Research Notes	275
Biology and Physiology	275
1/28/26 Ankle foot orthosis quick search	275
2/2/26 Dorsiflexion	276
2/2/26 FSHD	278
2/6/26 FSHD pt. 2	280
3/2/2026 "Steppage Gait"	281
Competing Designs	282
2/5/26 Push Ortho AFO by Brace Lab	282
2/6/26 Pro care super lite	284

3/13/26 Dynamic exoskeletal orthosis	286
3/13/26 Orthotics brace and system patent	288
Ethics	290
2/5/26 Patient Satisfaction of AFO	290
2/5/26 Inaccessability due to cost	292
2/20/26 Working with adolecents to make medical devices	294
2/20/26 Consent and other ethical concerns	295
Materials	296
2/13/25 Elastic polyester	296
2/13/26 TPU	297
2/13/26 Ballistic nylon	298
2/20/26 Dog bone MTS	299
2/27/26 Front toe sleeve material possibilities	301
Design Ideas	303
Toe sleeve 2/27/26	303
3/13/26 OnShape medial lateral supports 3/13/26	305
4/10/26 Half sock design and protocol	307
4/3/2026 Toe Sleeve design	308
3/21/2026 Heel strap design	309
Training Documentation	310
Chemical and Biosaftey Trainings	310
3/16/26 Semester Training HIPAA	311
Lecture Notes	312
Lecture 2 Library	312
2/4/25 Lecture 3	313
Lecture on diversity and inclusion	315
3/6/26 Tong Lecture	316
3/11/26 Protocal lecture	317
3/18/25 Lecture on concise	318
Ethics 3/25/26	319
Judgment 4/8/26	320
Posters help 4/15/26	321
Posters evaluation by peers 4/15/26 (copy)	322
Meeting	323
2/20/26 Preliminary presentation	323
2/13/26 BPAG Meeting, and updated Expenses from past semesters	324
2/27/26 Preliminary Report work	326
4/20/26 Final AFO Fabrication Day 1	327
4/23/26 Final AFO Fabrication Day 2	328
4/24/26 Final AFO Fabrication Day 3	330

**Team contact Information**

Alex Conover - Feb 03, 2026, 8:46 PM CST

Last Name	First Name	Role	E-mail	Phone	Office Room/Building
Ohnsorg	Monica	Advisor	ohnsorg@wisc.edu		2355 EHall
Eggleston	Debbie	Client	debmeegg@gmail.com		
Kahr	Samantha	TA	kahr2@wisc.edu		
Conover	Alex	Team Leader	ajconover@wisc.edu	9202415667	
Avery	Lyons	Communicator	allyons3@wisc.edu	2485150273	
Loosen	Sierra	BSAC	sloosen@wisc.edu	2622240487	
Kimmel	Kalob	BWIG, BPAG	kokimmel@wisc.edu	6083731788	

 **Project description**

Alex Conover - Feb 03, 2026, 8:52 PM CST

Course Number: BME 301**Project Name:** Inconspicuous AFO for Teen**Short Name:** Team AFO**Project description/problem statement:**

Ankle-foot orthoses (AFOs) are designed to support dorsiflexion during the swing phase of walking. They are commonly used in managing muscular dystrophies, and for this project, our focus is specifically on adolescents with Facioscapulohumeral Dystrophy (FSHD), the most prevalent form of muscular dystrophy [1]. Our goal is to create a brace that helps teens achieve safer walking by assisting ankle dorsiflexion, while remaining discreet, lightweight, and flexible enough to allow natural ankle motion. The main design priorities are to position the ankle in proper dorsiflexion, keep the brace slim and unobtrusive, and provide enough flexibility to reduce movement restrictions. This project has been ongoing throughout three semesters, and this semester, spring 2026, will be the final semester of the project; the team is hoping to create a device that fulfills all requests, as well as displays significant data.

About the client:

The client, Debbie Eggleston, is a physical therapist as well as an advocate for individuals with FSHD. She first introduced the team to the patient who would be receiving the AFO. Following a period of limited progress, Ms. Eggleston collaborated with specialists at the University of Michigan to confirm the patient's diagnosis of FSHD1 in December 2022. In addition to her clinical role, Ms. Eggleston has been an active advocate for FSHD awareness for over five years. She has worked closely with FSHD specialists, engaged in community outreach, and utilized social media platforms, such as Facebook groups, to fundraise and raise awareness for the condition.

This project was initiated in the Fall 2024 semester, during which the team met with Ms. Eggleston at multiple points to provide progress updates on the AFO design and manufacturing process. In turn, she shared updates regarding the patient's condition. As the disease has advanced to the point of requiring a professional-grade AFO, Ms. Eggleston has also connected the team with the patient's orthotist, ensuring that future groups can continue development in close collaboration with both the physician and herself. This semester will be the last time the team will work with Ms. Eggleston on this project.

Relative Information:

The patient is:

Height - 1.724 m (5' 7.87")

Weight - 53.4 kg (~118lb)

Shoe Size - 8.5-9 size shoes (womens)



01/26/2026 - Team Meeting 1

Alex Conover - Jan 26, 2026, 2:20 PM CST

Title: Team Meeting 1

Date: 01/26/2025

Content by: Alex Conover

Present: Alex, Avery, Sierra, Kalob

Goals: Establish the weekly meeting with the team, and update them on any other relevant information regarding the client and the project.

Content:

The team meetings will occur every Monday at 1pm, setting us up for a successful week.

Alex and Avery updated Sierra and Kalob on the current status of the project, detailing the work done in the last 3 semesters, and showing the current copy of the prototype that we have from Fall 2025. Clarifying questions were asked regarding the design, and how it was used in previous semesters; the medial/lateral supports are 3D printed with PLA 50% infilled carbon fiber, and the dorsiflexion strap is elastic polyester, and the supporting straps are nylon. We will likely do a lot of material testing this semester to be sure of the types of materials we are using, exactly how strong they are, and whether we should change them.

All important standing documents will be added to lab archives, the final notebook was added already, and the final report and PDS will also be added. The team will work to improve the PDS throughout the semester, and work to create a plan to upgrade the existing prototype for hopefully the final time.

Communication with the client was also established, and the team will try to meet with Mrs. Eggleston some time in the morning (around 8 or 9 am CST) tuesday mornings, as that works for everyone.

Research will be conducted in the following weeks, being sure to hit the marks for 2b and 4b as noted in the assignment. If it's ok, the 2 new members will do their own research, regardless of the research already done, so they may have overlapping sources, but they don't know that information. Avery and Alex will work to make sure they have no overlapping research with previous semesters.

Conclusions/action items:

Complete research entries to have 4 primary sources, following the 2b and 4b research requirements.

Complete the library research assignment as well as the resume and cover letter, tailored to a company, for the lecture this Wednesday.

Avery will send an update to Mrs. Eggleston to schedule a meeting time to receive the client's update.



02/02/2026 - Team Meeting 2

Alex Conover - Feb 11, 2026, 12:41 AM CST

Title: Team Meeting 2

Date: 02/02/2026

Content by: Alex Conover

Present: Alex, Avery, Sierra, Kalob

Goals: Meet and talk about the PDS, the progress report, and the client meeting on Tuesday Morning.

Content:

The team divided up the product design specifications, specifying what colors we will break up to detail the requirements for 301. Alex is red, Avery is yellow, Sierra is blue, and Kalob is green.

Some of the PDS is in need of heavy revision from the previous semesters, especially the materials section, which Avery is tackling. Some of the sections that will remain relatively untouched, specifically the standards and patents, are up to date from last semester, and we haven't seen anything different.

Questions for Debbie (at 8 am tomorrow):

1. Has Maggie been using the brace?
2. Is it comfortable? How is it holding up?
3. Is there, if any, discomfort? Pressure points?
4. Collaboration with the University of Michigan - Ann Arbor possibilities, discuss more on that.

Progress report will go out Thursday - Kalob will update the finances portion of the spreadsheet and include an itemized list of all 3 semesters this project has been running.

Conclusions/action items:

Continue work on the PDS and progress report.

Turn in the PDS on Thursday, as well as email the progress report out to Mrs. Eggleston.



02/09/2026 - Team Meeting 3

Alex Conover - Feb 11, 2026, 12:41 AM CST

Title: Team Meeting 3

Date: 02/09/2026

Content by: Alex Conover

Present: Alex, Avery, Sierra, Kalob

Goals: Meet Online to discuss goals for the week

Content:

The team decided to meet online this week to go to the career fair instead. (It lowkey wasn't worth it -Alex)

The team discussed the following:

- What fabrication needs to get done this week?
- What testing do we want to complete in the future?
- What categories do we want to include in the Design Matrix?
- What kind of update can we get out of Ms. Eggleston and Maggie this week?

Goals that became of the conversation:

- Someone (Alex/Kalob) will create an Onshape file for a TPU dogbone, print 2 or 3 copies, and then the team will be ready to test next week
 - the ballistic nylon needs to be cut to size as well (including the dogbone pattern), and the elastic polyester can be cut to size as well.
- MTS testing will be performed next week(?) barring any complications
- Design Matrix:
 - The team will be comparing the different types of materials used in dorsiflexion (TPU, polyester, ballistic nylon)
 - New categories and weights will be created for this matrix, including the following:

Design Criteria	Material 1: Elastic Polyester		Material 2: TPU		Material 3: Ballistic Nylon	
	Raw Score	Weighted Score	Raw Score	Weighted Score	Raw Score	Weighted Score
	Dorsiflexion Support (30)	/5		45		/5
Durability (20)	/5		/5		/5	
Flexibility (15)	/5		/5		/5	
Fabrication Quality (15)	/5		/5		/5	
Discreetness (10)	/5		/5		/5	
Cost (10)	/5		/5		/5	
Total	/100		/100		/100	

- To be filled out and turned in this Thursday with the progress report.

- Avery to email the client to receive an update on our request to wear the brace for 2 days straight.

Conclusions/action items:

Complete the design matrix and progress report for the week.

Avery to reach out again as a reminder for the data the team needs.

Find out what time works for materials testing next week.



02/16/2026 - Team Meeting 4

AVERY LYONS - Feb 16, 2026, 12:29 PM CST

Title: Team Meeting 4

Date: 02/16/2026

Content by: Avery Lyons

Present: Alex, Avery, Sierra, Kalob

Goals: Meet Online to discuss goals for the week

Content:

-Ideas

+ 2 braces: one with TPU straps and one with polyester

+ MTS testing Thursday?

+ Testing prototypes after spring break?

-- first find a UMich professor to see if we can test

-- ship prototypes

+ created Preliminary presentation slides

Conclusions/action items:

Complete the preliminary presentation and progress report for the week.

Find out what time works for materials testing next week.



02/19/2026 - Team Meeting 5

AVERY LYONS - Feb 19, 2026, 7:22 PM CST

Title: Team Meeting 5

Date: 02/19/2026

Content by: Avery Lyons

Present: Alex, Avery, Sierra, Kalob

Goals: Meet Online to discuss goals for the week and practice presentation

Content:

- Completed TPU, polyester, and ballistic nylon MTS testing
- lots of slippage
- See Alex's notes for further details
- Practiced presentation
- Few changes made (e.g. formatting, bolding, and pacing)
- Invited client via Zoom
- Discussed feedback from Maggie: front strap is slipping backwards
- Ideas: add grippy portion, reduce length of strap to increase tension

Conclusions/action items:

Complete the preliminary presentation tomorrow morning and get feedback/suggestions on our prototype.



02/25/2026 - Team Meeting 6 (in lecture)

Alex Conover - Feb 25, 2026, 1:59 PM CST

Title: Lecture DEI Assignment

Date: 02/25/2026

Content by: Alex

Present: Team

Goals: Understand and Comprehend DEI in engineering.

Content:

BME Code of Ethics - Assignment

- What components of your design can be improved?

- Different colors (doesn't have to be black/gray)
- different sizes (for overall scope of the project...)
- easier to use

- Which of the 7 principles are you addressing?

3. simple and intuitive use - how to make our product easier to use? (instruction manual)

5. Tolerance for Error - how can we eliminate sharp edges if our product breaks?

6. Low Physical Effort - how can we make the ergonomics of this design better

- How can you make these improvements?

- Create an instruction manual for our design with clarifying images and descriptions, it would make it easier to use and understand.

- Make it easier to determine medial and lateral sides...

Conclusions/action items:

We can implement these ideas from the brainstorming session and upgrade our design to be more universally accessible. A lot of the principles involved with universal design could be implemented to make our design more applicable to the "average" patient, versus our very personalized design right now.



03/02/2026 - Team Meeting 7

Alex Conover - Mar 02, 2026, 1:44 PM CST

Title: Team Meeting 6

Date: 03/02/2026

Content by: Avery Lyons

Present: Alex, Avery, Sierra, Kalob

Goals: Meet in ECB to discuss goals for the week and practice presentation

Content:

- List of materials needed for UMich contact

+ Contact: Aidan Shoresh, graduating ME at UMich, 248-878-5870

+ force plate, motion capture if possible

- Created schedule to plan out deliverables

- Ideas to mitigate slippage

+ Add piece of grippy sock to bottom of strap or add adhesive beads to bottom

- PVC for durability/affordability

-Silicon for comfort and superior grip

- Hot glue dots? Possibly too brittle

+ Sock cap

- Uses toes

- Goals this week:

+ parse MTS testing data for elastic modulus, graph stress-strain curves together to compare, yield strength, and ductility

- Draft testing plans

-Fabrication

Schedule for the rest of the semester:

March 2026

Sunday	Monday	Tuesday	Wednesday	Thursday	Friday	Saturday
1	2	3	4	5	6	7
	Draft Testing Plans (Avery Alex)				TONG (Probably)	
	Parse Data from MTS Testing...? (Sierra)			Update & Print	In/Ev Sides (Kalob)	
8	8	9	10	11	12	13
Brace needs: -side upgrades -dorsiflexion	Fabrication of New Brace ↳ (Monday) (ins) ↳ Ballistic Nylon, do we need more?		Testing Plans due thur		Notebook Check BSAC	Finish Braces...
15	16	17	18	19	20	21
	Ship Prototype				Show & tell	
22	23	24	25	26	27	28
	Work out testing plans with michigan / Only w/ Maggie				BSAC	
29	30	31	1	2	3	4
	430 Exam 2		Confirm Testing Plans			
						

April 2026

Sunday	Monday	Tuesday	Wednesday	Thursday	Friday	Saturday
29	30	31	1	2	3	4
	spring break			Executive Summary Draft due 11:59		
5	6	7	8	9	10	11
	Parse Data from Testing				BSAC	
	Draft Final Report (Scratch)					
12	13	14	15	16	17	18
	Draft Poster				No meeting - EXP 4/17 11:59pm Final Executive Draft	
	Draft Executive Summary					
19	20	21	22	23	24	25
	Finish Final Report		Bring Poster to Class		Final Poster Prez (due 10am)	
26	27	28	29	30	1	2
		Final Deliverables		430 Exam 3		

Conclusions/action items:

We will be analyzing the MTS testing data, drafting testing plans, and beginning to fabricate. Next week, we will meet in the Makerspace to fabricate. Kalob will focus on CAD and printing, Sierra will focus on MTS data, and Alex and Avery will focus on testing plans.



03/16/2026 - Team Meeting 8

AVERY LYONS - Mar 16, 2026, 1:41 PM CDT

Title: Team Meeting 8

Date: 03/16/2026

Content by: Avery Lyons

Present: Alex, Avery, Sierra, Kalob

Goals: Meet online to discuss goals for the week

Content:

- BME contact did not work out
- + BME department doesn't have force plate
- + Alex to contact Directors of HPSSC to see if they have a force plate
- + If not, then we will use OpenCap to test
- continued working on fabrication protocols
- Questions
- + How can we make the brace more aesthetically pleasing?
- ++ 3D printing, smoother outside edges, no fraying
- Can anyone help with sewing machine?
- Ways to help eliminate strap slipping?
- Tips for OpenCap long-distance if necessary

Conclusions/action items:

- + Coordinate with UMich Kinesiology to check about force plate availability
- + Finish fabrication plans tonight



03/23/2026 - Team Meeting 9

Alex Conover - Apr 07, 2026, 1:41 PM CDT

Title: Before Break (And 430 Exam) Meeting

Date: 03/23/2026

Content by: Alex Conover

Present: Alex, Avery, Sierra, Kalob

Goals: Virtual Meeting to establish goals for the week and spring break.

Content:

We spoke about finishing any remaining testing protocol that might need to be finished or changed, since we now have to work with OpenCap as U Mich denied our request.

But wait! An email from Debbie! She talked to Peter, and we might be able to test with the U Mich department after all.

Conclusions/action items:

Have a good spring break and monitor email over break to see if anything pops up.



04/06/2026 - Team Meeting 10

Alex Conover - Apr 08, 2026, 1:12 PM CDT

Title: Team Meeting 10

Date: 04/06/2026

Content by: Alex Conover

Present: Avery, Alex, Sierra

Goals: Re-assess and figure out where we're at post-break.

Content:

The team met to work on the executive summary and figure out what kind of testing plans we need to work on.

We literally, during the meeting, received confirmation that we could test with the University of Michigan's Kinesiology departments stuff. We will continue to work on testing plans, because U-Mich has a lot of facilities for us to use, which were detailed in this email:

Lower Limb Lab 1 (Room 1600) is a 2741 square-foot space equipped with all necessary equipment to perform standard biomechanical assessments. Kinematic data is collected via a 16-camera digital motion analysis system (Qualisys, Göteborg, Sweden). Seven force platforms (AMTI, Watertown, MA) are embedded in the ground to collect kinetic data. The space also contains a staircase with embedded force plates to measure ground reaction force and load cells to measure force on the handle bars (Berotec, Columbus, OH). A custom-built Likorall (Hill-Rom Co., Batesville, IN) overhead lift system surrounds the lab to prevent participants from falling when walking overground or on the stairs. The lab also has a second capture area with an additional 10-camera motion capture system surrounding a split belt treadmill with two embedded force plates (Berotec, Columbus, OH). A support rail for a harness surrounds the treadmill. Both spaces have 16-channel wireless electromyography systems (Delsys Inc., Boston, MA, USA). Additionally, the lab houses a custom-device to measure the stiffness of ankle-foot orthoses and a robotic system to emulate assistive technology such as exoskeletons and prostheses through off-board actuation (Humotech, Pittsburgh, PA).

So that was fun!

Wednesday evening, we will send up any remaining questions for the testing protocol.

Conclusions/action items:

Testing to be completed this week! At Michigan!



04/13/2026 - Team Meeting 11

Alex Conover - Apr 16, 2026, 1:55 PM CDT

Title: Team Meeting 11

Date: 04/13/2026

Content by: Alex Conover

Present: Avery, Alex, Sierra, Kalob

Goals: Assess the data we received from UMich and plan out the rest of the semester.

Content:

The team met up to assess the data received from UMich; the testing files will be shared with us later today and we will start analyzing as soon as we have the data.

Kalob showed us his sock idea with the dorsiflexion strap, and it looks like it would work well. We could implement this into the final design we may or may not make.

We also need to recontact Debbie about the comfort survey. The testing went longer than they thought it would and they ended up speeding through it at the end of testing,

Conclusions/action items:

Data to be analyzed later this week once it's received. Client and patient to be contacted about the comfort survey.



04/20/2026 - Final Team Meeting 12

Alex Conover - Apr 27, 2026, 2:38 PM CDT

Title: Final Team Meeting

Date: 04/20/2026

Content by: Alex Conover

Present: Whole Team

Goals: Establish what else needs to be finished for the final poster and report.

Content:

The team went over the final report, fleshing out some areas and leaving others for later. The poster was the main focus, as we wanted it to be mostly done by Wednesday, so we could print the poster by Thursday at the latest.

The team also just received the right data (.mat files) so the analysis has just begun. Alex and Sierra are doing the analysis and will upload to the poster when completed.

The team will also print the final iteration of the prototype with a different material for a sleeker finish.

Conclusions/action items:

Kalob to update the group on prototype printing.

Alex and Sierra to finish the statistical Analysis of the data.



02/03/26 Client Meeting 1

AVERY LYONS - Feb 03, 2026, 8:21 AM CST

Title: Client Meeting 1

Date: 2/03/2026

Content by: Avery Lyons

Present: Avery, Kalob, Alex, and Sierra

Goals: The goal is to discuss updates with the client and receive design suggestions based on Maggie's use of the AFO in the past 2 months.

Content:

- Client Questions as decided in 02/02/26 team meeting:
 - 1. Has Maggie been using the brace?
 - confused on how to use brace
 - wasn't sure if they had the dorsiflexion aspect
 - 2. Is it comfortable? How is it holding up?
 - 3. Is there, if any, discomfort? Pressure points?
 - 4. Collaboration with the University of Michigan - Ann Arbor possibilities, discuss more on that.
 - Maggie goes twice a year to UofM for doctor appts
 - encouraging her to wear the regular AFO
 - Questions are irrelevant: not wearing the brace
 - had gait analysis at Ohio State University
 - for UofM contacts, Debbie will contact the doctors first to see if they have any BME contacts then Avery will check if need be
 - Debbie has a niece, Maria
 - Dr. Justin Williams, past advisor, used to be a professor at Michigan- may have contacts
 - Wayne State University is another possible avenue- Avery has many contacts
 - Dr. Cynthia Bir
 - maybe check in with Peter Adamczyk- difficult due to sabbatical but is a friend to Debbie
- Design Ideas
 - Polyester straps to TPU to increase dorsiflexion support
 - mediolateral support is secondary
 - toes must be up for heel strike

Conclusions/action items:

We will have a graded notebook check next week Friday. The PDS is due Thursday. As a team, we need to work with the client (Debbie) to find a way to encourage Maggie to actually wear the brace. Her condition will not improve nor change if she does not wear it.



01/30/26 Advisor Meeting 1

AVERY LYONS - Jan 30, 2026, 2:02 PM CST

Title: Advisor Meeting 1

Date: 1/30/2026

Content by: Avery Lyons

Present: Avery, Kalob, Alex, and Sierra

Goals: The goal is to meet our new advisor, discuss semester expectations, and complete a notebook check.

Content:

- Explained past project and actions to advisor
 - past designs (i.e. Fall 2024, Spring 2025, Fall 2025, ideas for this semester)
- Advisor said to possibly contact Adam Check
- Progress reports due by 8 PM on Thursdays
- each teammate presented their LabArchives research
- explained terminology to the advisor
 - dorsiflexion, mediolateral, etc.
- Sierra was asked about her new ideas
 - Goals: most comfortable design
- Kalob asked about his new ideas:
 - SolidWorks, carbon fiber usage, more coverage AFO vs. bringing down mediolateral sides to the floor
- Advisor ideas:
 - maybe find strap alternative due to wear and tear, maybe find a material that can take a lot of flexion

Conclusions/action items:

We will have a graded notebook check next week Friday. The PDS is due Thursday. The client meeting is scheduled for Tuesday morning at 8 AM.



02/06/26 Advisor Meeting 2

AVERY LYONS - Feb 06, 2026, 2:05 PM CST

Title: Advisor Meeting 2

Date: 2/06/2026

Content by: Avery Lyons

Present: Avery, Kalob, Alex, and Sierra

Goals: The goal is to meet our new advisor, discuss the past client meeting, and complete a notebook check.

Content:

- Explained how client meeting went
 - patient has no used prototype/not sure if it was received
 - waiting on final updates
 - have a second prototype that we can send
 - possibly have her wear prototype for 2-3 straight days to get feedback on pressure points, comfortability, etc.
 - received some info on some professors that we could possibly collaborate with at the University of Michigan for testing
- Presented notebooks

Conclusions/action items:

The PDS is updated and turned in. The team presented our weekly research and discussed next step suggestions. We are awaiting an update to see if the client has officially received the AFO. We are going to do some MTS testing this week using a bone shaped TPU. The image below is from Sierra's notebook.

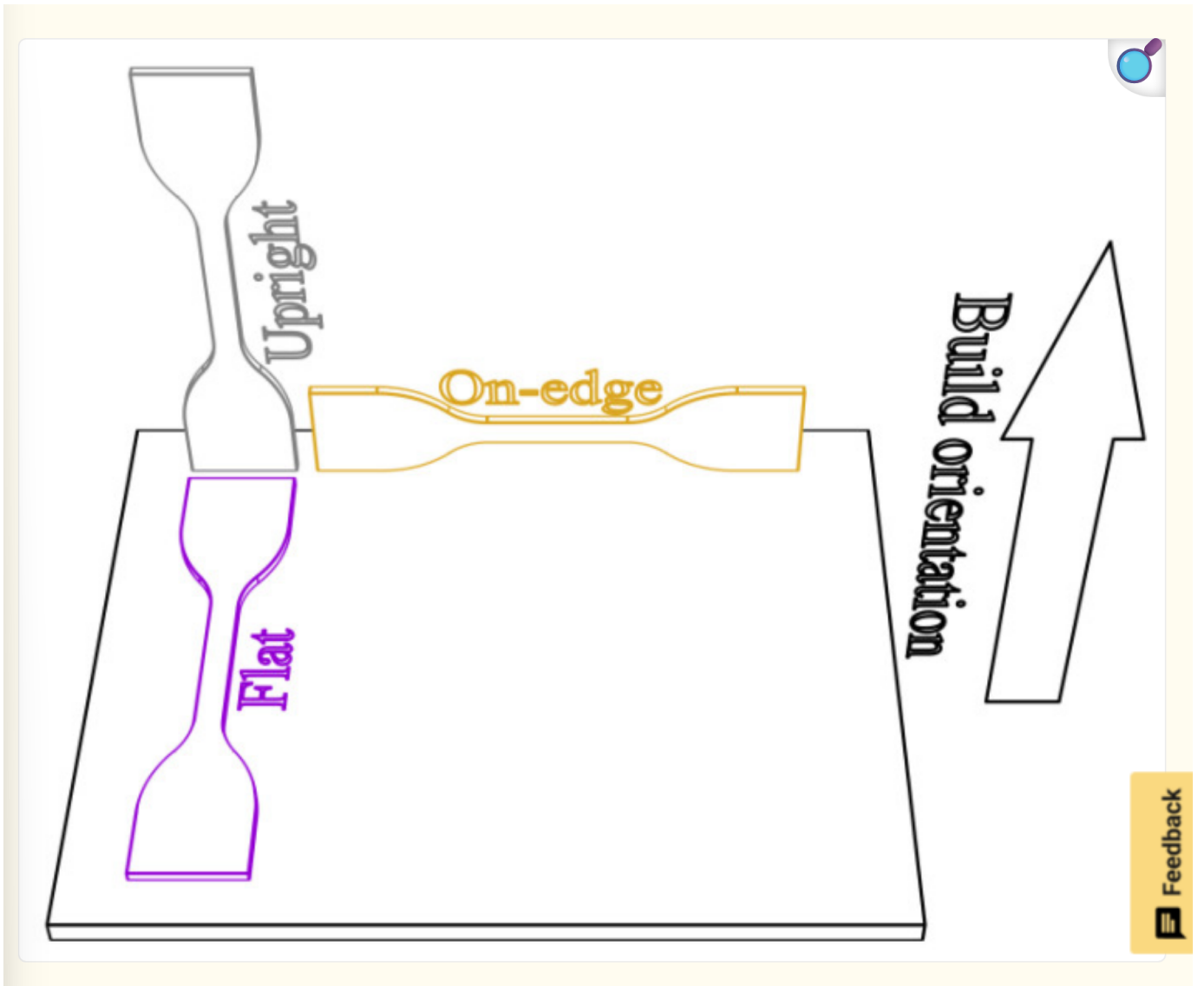



02/13/26 Advisor Meeting 3

AVERY LYONS - Feb 13, 2026, 1:43 PM CST

Title: Advisor Meeting 3

Date: 2/13/2026

Content by: Avery Lyons

Present: Avery, Kalob, Alex, and Sierra

Goals: The goal is to meet our new advisor, discuss the preliminary presentations, and complete a notebook check.

Content:

- Client has given us update
 - wants us to text Maggie's personal number to encourage her to wear the brace
 - waiting on Peter to do an intro to the University of Michigan professor, Dr. Brian Umberger
 - hasn't heard from him yet
 - will reach out to professor directly if she can't reach Peter
 - if none of this pans out, she will reach out to the other professors

Conclusions/action items:

The PDS is updated and turned in. The team presented our weekly research and discussed next step suggestions. We are awaiting an update to see if the client has officially received the AFO. We are going to do some MTS testing this week using a bone shaped TPU. The image below is from Sierra's notebook.



03/06/26 Advisor Meeting 4

SIERRA LOOSEN - Mar 06, 2026, 1:56 PM CST

Title: Advisor Meeting 4

Date: 3/6/26

Content by: Sierra

Present: Sierra, Kalob, Alex

Goals: Update Dr. Ohnsorg and Sam on our project status

Content:

- We are actively working on analyzing MTS data
- Kalob is working to change the Onshape file so that we can get the side pieces printed out for the brace
- We made our calendar for the rest of the semester
- Team fabrication on Monday of the new brace
- We want to get the brace fabricated done as soon as possible and get it shipped to Michigan
- Dr. Ohnsorg thinks that TPU doesn't have enough elasticity for what we need
 - If we decrease the length of the elastic polyester strap, this might fix the issues with the current prototype
 - She thinks we should probably stick with elastic polyester
- We might also implement a toe cover to hold the strap in place

Conclusions/action items:

Next week, we will start fabricating the brace so we can get it sent to Michigan for testing. We are still coordinating with Avery's contacts in Michigan to get testing done with Maggie at the University of Michigan.



03/13/26 Advisor Meeting 5

AVERY LYONS - Mar 13, 2026, 2:02 PM CDT

Title: Advisor Meeting 5

Date: 3/13/26

Content by: Avery

Present: Sierra, Kalob, Alex, Avery

Goals: Update Dr. Ohnsorg and Sam on our project status

Content:

- Preliminary Report comments
 - Appendices
 - Effective use
 - Every appendix is there for a reason
 - If included, must be referenced somewhere in report
- Good job updating PDS!
- Update: found UMich contact that is BME: Catherine Liang
 - she is going to talk to one of her professors to see if he can help
- Notebook checks

Conclusions/action items:



04/10/26 Advisor Meeting 6

AVERY LYONS - Apr 10, 2026, 1:53 PM CDT

Title: Advisor Meeting 6

Date: 4/10/26

Content by: Avery

Present: Sierra, Kalob, Alex, Avery

Goals: Update Dr. Ohnsorg and Sam on our project status

Content:

- Updates
 - Force plate testing to occur with U of Michigan Kinesiology tomorrow
 - sent testing protocol
 - Proctors of test:
 - Havi Razavi (PhD student) and Dr. Deanna Gates (Leading professor)
 - Parse data: Origin or MATLAB or RStudio
 - Submitted for Excellence Award
 - Kalob made sock-attachment and protocol
 - Made it too big to fit his own foot- will update

Conclusions/action items:

We can decide if we want to meet next week. We will use Word for the final report. We are going to make a final product using thermoforming to make the best aesthetic product. We will await Sam's review of our Executive Summary Draft.

**02/06/2026 - PDS**

Alex Conover - Feb 13, 2026, 1:41 PM CST

Title: PDS Upload**Date:** 02/06/2026**Content by:** Alex Conover**Present:** All**Goals:** Upload the PDS to lab archives.**Content:**

Here is the PDS uploaded for convenience. We will be updating this document throughout the semester as our project is fully formed.

Conclusions/action items:

Work on the preliminary presentation, as well as weekly documents.

Alex Conover - Feb 12, 2026, 4:44 PM CST

**Inconspicuous Ankle Foot Orthosis (AFO) for teen**

PRODUCT DESIGN SPECIFICATIONS (PDS)

Team Name:
Team: AFO**Team Members:**
Alex Conover (Team Leader)
Alex Lutz (Chairman)
Serra Lovans (BSAC)
*Kaleb Kinross (BHW, SPAG)***Client:**
Debbie Eggelross**Advisor:**
Dexter-Marcus Obersteg, University of Wisconsin - Madison

February 5th, 2026

[Download](#)**Color_Copy_-_Product_Design_Specifications_-_AFO_for_Teen.pdf (356 kB)**



02/12/2026 - Dorsiflexion Materials Design Matrix

Alex Conover - Feb 12, 2026, 4:26 PM CST

Title: Dorsiflexion Materials Design Matrix

Date: 02/12/2026

Content by: Alex Conover

Present: N/A

Goals: Flesh out the beginning of the Design Matrix.

Content:

The team worked to create the design matrix, specifically fleshing out the specifications for what the team will grade the materials on. Further information is necessary (more research) for each team member before we grade the matrix to decide what material. We may also perform testing to decide which material to create.

Conclusions/action items:

Rate each of the categories for the matrix to decide what material to use.

Perform testing to help decide what material - then finish the matrix.

Alex Conover - Feb 12, 2026, 4:26 PM CST

Table 1: Dorsiflexion Material Design Matrix

Design Criteria	Material 1: Elastic Polyester		Material 2: TPU		Material 3: Ballistic Nylon	
						
	Raw Score	Weighted Score	Raw Score	Weighted Score	Raw Score	Weighted Score
Dorsiflexion Support (25)	0.5		0.5		0.5	
Durability (15)	0.5		0.5		0.5	
Flexibility (15)	0.5		0.5		0.5	
Fabrication Quality (15)	0.5		0.5		0.5	
Comfort (10)	0.5		0.5		0.5	
Discreetness (10)	0.5		0.5		0.5	
Cost (10)	0.5		0.5		0.5	
Total		/100		/100		/100

Dorsiflexion Support (25%): The material chosen needs to be able to provide ample dorsiflexion support in order to improve the swing, heel strike, and mid-stance phases for the consumer's gait. This ultimately corrects the body's adaptive strategies that deal with the compromised gait such as early heel rise, foot dragging, circumduction, and steppage gait.

[Download](#)

Spring_2026_Design_Matrix_Criteria.pdf (3.54 MB)



02/19/2026 Updated Design Matrix

AVERY LYONS - Feb 19, 2026, 5:18 PM CST

Table 1: Dorsiflexion Material Design Matrix

Design Criteria	Material 1: Elastic Polyester		Material 2: TPU		Material 3: Ballistic Nylon	
	Raw Score	Weighted Score	Raw Score	Weighted Score	Raw Score	Weighted Score
Dorsiflexion Support (25)	3.5	13.25	4.5	20.25	5.5	23.25
Durability (15)	4.5	12.15	3.5	9.15	4.5	12.15
Flexibility (15)	5.5	13.15	4.5	12.15	2.5	6.15
Fabrication Quality (15)	2.5	9.15	4.5	12.15	3.5	9.15
Comfort (10)	4.5	10.10	4.5	8.10	3.5	6.10
Discretion (10)	4.5	8.10	4.5	8.10	4.5	8.10
Cost (10)	3.5	6.10	3.5	10.10	2.5	4.10
Total		75.100		79.100		70.100

Dorsiflexion Support (25%): The material chosen needs to be able to provide ample dorsiflexion support in order to improve the swing, heel strike, and mid-stance phases for the consumer's gait. This ultimately corrects the body's adaptive strategies that deal with the compromised gait such as early heel rise, foot dragging, circumduction, and stepping gait.

[Download](#)

Spring_2026_Design_Matrix_Criteria.pdf (4.21 MB)



02/19/2026 Preliminary Presentation Slides

AVERY LYONS - Feb 19, 2026, 5:19 PM CST



[Download](#)

Spring_2026_-_Prelim_Presentations.pdf (2.03 MB)



04/25/2026 - Final Poster

Alex Conover - Apr 27, 2026, 12:32 PM CDT

Title: Final Poster Upload

Date: 04/25/2026

Content by: Alex Conover

Present: N/A

Goals: Upload the final poster to lab archives

Content:

Final poster is uploaded below, and it was a great performance from the team. We scored well and only had one mishap on the questions.

Conclusions/action items:

See poster below!

Alex Conover - Apr 27, 2026, 12:33 PM CDT



[Download](#)

Final_Poster_-_AFO_for_Teen_2_.png (31.2 MB)



04/29/2026 - Final Report

KALOB KIMMEL - Apr 29, 2026, 5:40 PM CDT

Title: Final Report Upload

Date: 04/29/2026

Content by: Kalob Kimmel

Present: N/A

Goals: Upload the final report to lab archives

Content:

Final Report is uploaded below!

Conclusions/action items:

See Report below!

KALOB KIMMEL - Apr 29, 2026, 5:38 PM CDT



[Download](#)

Team_AFO_-_Final_Report_04_29_2026.pdf (22.9 MB)



02/18/2026 - Materials Printing and Manufacturing

Alex Conover - Feb 18, 2026, 4:58 PM CST

Title: Materials Manufacturing

Date: 02/18/2026

Content by: Alex Conover

Present: Kalob Kimmel, Alex Conover

Goals: Print new TPU test strips and fabricate the other dogbone pieces.

Content:

Kalob worked to create the CAD file to print out three dogbone test strips to use in MTS testing 02/19. The file is linked below.

Alex cut out the dogbone pattern in the ballistic nylon, using scissors. The ballistic nylon fabric is easily fray-able, so extra care was used when cutting the samples.

Conclusions/action items:

Use the samples in testing on 2/19, and report back with any discrepancies in the test files.

KALOB KIMMEL - Feb 19, 2026, 11:40 AM CST



[Download](#)

Dog_Bone.SLDPRT (75.6 kB)



04/29/2026 - Final Expenses

KALOB KIMMEL - Apr 29, 2026, 5:41 PM CDT

Title: Final Expenses Upload

Date: 04/29/2026

Content by: Kalob Kimmel

Present: N/A

Goals: Upload the final Expenses to lab archives

Content:

Final Expenses is uploaded below!

Conclusions/action items:

See below!

Item	Description	Manufacturer	Vendor	Date	QTY	Cost Each	Total
Side bases							
PLA CF	Medial & lateral PLA CF print	Makerspace	design lab	3/8/2026	1	\$2.47	\$2.47
Tough 1500	Medial & lateral Tough 1500 print	Makerspace	design lab	4/23/2026	86.1	\$0.25	\$21.53
Straps and Padding							
TPU	Tpu print of doge bone for MTS testing	Makerspace	Design Lab	2/18/2026	3	\$0.17	\$0.51
Superglue	Adhesive used for attaching padding to supports		Design Lab	3/9/2026	1	\$1.50	\$1.50
Elastic Fabric	Fabric used to prototype with sock		Design Lab	4/9/2026	1	\$1.00	\$1.00
Hair clips	Used for sock prototype	Splendorflying	Amazon	4/1/2026	1	\$3.99	\$3.99
						TOTAL:	\$31.00



3/10/2026 - AFO Fabrication

AVERY LYONS - Mar 16, 2026, 1:13 PM CDT

Title: AFO Fabrication

Date: 3/10/26

Content by: Sierra

Present: Sierra, Alex, Avery, Kalob

Goals: Complete fabrication of the AFO

Content:

Today, the team fabricated the AFO. Kalob had previously printed out the PLA-CF inversion and eversion supports. We cut out two pieces of mesh padding for each hard side plate. Alex and Avery (after a valiant fight with the sewing machine) hand sewed the mesh pieces together. Then Alex's hands got covered in super glue while gluing the mesh padding to the PLA-CF. Avery and Kalob worked on sewing the back straps to the PLA-CF. Alex sewed the dorsiflexion strap together (and stabbed herself multiple times). Then, the front strap was sewed on, and the velcro was added.

**Conclusions/action items:**

A majority of the fabrication is done. The team just needs to add on the new portion of the AFO, which is the toe strap. This will be attached to the dorsiflexion strap to hold it in place. The dorsiflexion strap needs to be cut to approximately 15 inches and sewed on.



3/12/2026 - AFO Fabrication 2

SIERRA LOOSEN - Mar 12, 2026, 10:41 AM CDT

Title: AFO Fabrication 2

Date: 3/12/26

Content by: Sierra

Present: Sierra and Alex

Goals: Complete the dorsiflexion strap and toe sock fabrication for the AFO

Content:

We first cut a shorter dorsiflexion strap to put on the new AFO. I then sewed the ends of the dorsiflexion strap together. Alex sewed the velcro pieces on to the front strap. Alex then sewed the long edges of the dorsiflexion strap together.

Conclusions/action items:

We are still debating whether or not we should implement the toe sock portion into the design. We have found some scrap fabric that we could use. We also are thinking of potentially buying a sock and cutting the toes off to use for our design.

Alex Conover - Mar 12, 2026, 12:08 PM CDT



[Download](#)

IMG_5532.jpeg (3.84 MB)

Alex Conover - Mar 12, 2026, 12:08 PM CDT

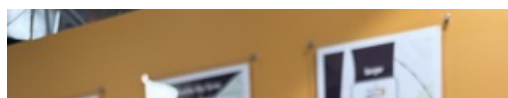



[Download](#)

IMG_5531.jpeg (3.62 MB)

Alex Conover - Mar 12, 2026, 12:08 PM CDT



[Download](#)

IMG_5530.jpeg (3.79 MB)

Alex Conover - Mar 12, 2026, 12:08 PM CDT



[Download](#)

IMG_5529.jpeg (3.44 MB)

Alex Conover - Mar 12, 2026, 12:08 PM CDT



[Download](#)

IMG_5528.jpeg (3.88 MB)



03/23/2026 - Fabrication Plans

Alex Conover - Apr 16, 2026, 1:57 PM CDT

Title:

Date:

Content by:

Present:

Goals:

Content:

Conclusions/action items:

Alex Conover - Apr 16, 2026, 1:57 PM CDT

Fabrication Plans for Inconspicuous AFO for Teen

Team Members: Alex Conover, Avery Lyons, Sierra Loosen, Jakob Kimmel
Advisor: Dr. Monika Dhruag, University of Wisconsin-Madison
TA: Sam Kahr
BME 301, Section 304

Material	Quantity	Cost
Mold of patient foot	1	N/A
CF-PLA	*See print details	\$9.00
Ba/BkGc nylon	24 in ²	\$12.61 for fabric
Polyester	38 in	\$7.99
Mesh fabric	*See print details	\$16.99 for fabric
Velcro	2 in ²	\$4.99
Black thread	1 spool	\$2.50/spool (has to use at Wendt)
Sewing kit	1 kit	\$14.99/kit (free use of team members kit)
Superglue	0.07 oz bottle	\$1.25
Fabric scissors	1 pair	N/A
White fabric pencil	1	N/A
Exacto knife	1	N/A
Bambu 3D Printer	1 printer	N/A

*Cost per brace is approximately \$53

Name of fabrication step/portion of prototype: R: Designing and Printing the Medial and Lateral Supports of the AFO
Date to be completed: 03/29/2026
Team Members fabricating: Jakob
Detailed Illustrated Steps of fabrication:

[Download](#)

Spring_2026_-_Fabrication_Plans_.pdf (6.1 MB)



02/19/2026 - MTS Testing Protocol

Alex Conover - Feb 18, 2026, 4:42 PM CST

Title: MTS Testing Protocol for 2/19 Materials Testing

Date: 02/19/2026

Content by: Alex Conover

Present: N/A

Goals: Detail the process we will be following for MTS testing of our 3 materials.

Content:

The protocol the team will follow for testing is relatively simple. The team needs to test 3 samples each of TPU filament, elastic polyester, and ballistic nylon. There will be 9 tests done, each a tensile test, and the average values will be considered when determining the modulus.

First, the TPU dogbone will be tested. Three trials will be run. The gauge distance will be measured each time to ensure the accuracy of the values recorded by the MTS machine.

The elastic polyester will be tested second, with 3 trials also being performed.

- This test may have some finagling to do, since the last test we performed with the polyester, it slipped out of the grips. Possible solutions to this problem include bringing more fabric up into the grips for more surface area to grip or adding a secondary substance to ensure it stays in the grips.

The ballistic nylon will be tested last. It will have 3 trials performed, and I'm expecting similar issues in the slippage, as that material is inherently more slippery than the elastic polyester.

When the data has been collected, the team will work together to calculate the elastic modulus, and graph the stress/strain curves leading to failure of the material. This will help determine which material to move forward with in our design.

Conclusions/action items:

Perform the MTS testing!

Do the presentation...

Add the data from testing to the preliminary report.



04/06/2026 - Testing Protocol at UMich

Alex Conover - Apr 27, 2026, 12:20 PM CDT

Title: Umich Testing Protocol

Date: 4/16/2026

Content by: Alex Conover

Present: N/A

Goals: Upload the testing protocol we sent to the University of Michigan.

Content:

The testing protocol had to be extremely well defined as the team sent the protocol to the University of Michigan to perform on our behalf. The Department of Kinesiology allowed us to test with their force plates and motion capture.

Conclusions/action items:

See attached document for full testing plans.

Alex Conover - Apr 16, 2026, 1:58 PM CDT

Testing Plans for Inconspicuous AFO for Teen - UMich Forceplate testing

Team Members: Alex Conover, Avery Lyons, Sierra Lawson, Kaleb Kimmel
Advisor: Dr. Monika Chmura, University of Wisconsin-Madison
TA: Sam Kahr

Date of Testing: TBD, but hoping for the week of UW spring break(?)
Location of Testing: University of Michigan - Ann Arbor

Devices to Test:

- Fall 2025 Model (Elastik Polyester Crossflexion Strap, original length)
- Spring 2026 Model (SP Dorsiflexion Strap, Lengthened Medial/Lateral Component)

Previous Testing:

The previous testing for this project was performed in November of 2025, with the Fall 2025 team (which included Avery and Alex) the testing performed was a gait analysis, followed by a stability gait analysis of balance path length. The goal was to see if the preliminary design ideas improved the gait of the patient, while also improving the overall balance. Photos of the brace tested can be seen in the Testing Analysis Document. The final iteration of the design was created post-testing can be found below.



Figure 1: Final Fall 2025 AFO brace

This iteration of the brace was never tested, as it was completed post-testing, and elements from testing were iterated into the brace. The team has received feedback from the patient about the feel of this brace: it feels good, works well from what she can tell, and doesn't have the uncomfortable rubbing against the medial of the ankle.

[Download](#)

Testing_Plans_-_03_05_2026.docx (1.34 MB)

 **02/19/2026 - MTS material testing**

Alex Conover - Feb 19, 2026, 11:33 AM CST

Title: MTS Materials Testing

Date: 02/06/2026

Content by: Alex Conover

Present: Alex Conover

Goals: Collect the data from materials testing with the MTS machines.

Content:

Elastic Polyester	TPU	Ballistic Nylon
Length = 8.5 in, Width 1/32 in, gauge 4.1 in *Material is bunched up in the clamps to ensure adequate testing. rate = 100 mm/s	gauge = 4.7 in, see materials printing for dimensions. * testing rate remains 50 mm/s no visible nicks scratches, or any damage to this specimen	Length = 7.75 in, width = 1 in, thickness = 1/32 in gauge = 3.3 in testing rate 25 mm/s, fabric is scrunched to see if breakage will occur - no breakage, scrunch fail?
8.4 in, width - 1/32, gauge = 3.75 *material is pre-stretched to try and test breakage? slower rate, (75 mm/s)	gauge = 4.7 in. testing rate remains 50 mm/s no visible breakage on the specimen :(Length = 7.6 in, width = 1 in, thickness = 1/32 in, gauge = 3.5 in. testing rate 25 mm/s - no breakage
7 in length, width 1/32 in, gauge = 4.8 in * less bunching, slower rate (50 mm/s)	gauge = 4.3 in. testing rate depleted to 25 mm/s no visible breakage, but more stretch?	Length = 7.9 in, width = 1 in, thickness = 1/32 in, gauge = 4.25 in testing rate 25 mm/s - no failure

ugh

Conclusions/action items:

Parse data and determine elastic modulus.

Graph the stress/strain curves and determine which material would be best usable for our project.



3/2/2026 - MTS Data Analysis

SIERRA LOOSEN - Mar 07, 2026, 12:33 PM CST

Title: MTS Data Analysis

Date: 3/2/26

Content by: Sierra

Present: N/A

Goals: Analyze the data collected from MTS testing of our three materials

Content:

I used MATLAB to analyze the data that Alex collected during MTS testing. This includes making a stress-strain (see below) curve for each trial, which includes three trials for three materials. I didn't calculate the Young's Modulus for each trial because these values may not actually be reliable since the material was slipping out of the machine during testing. The materials also were not tested to failure due to the slippage.

Conclusions/action items:

The data for each of the three materials was analyzed. The data may not be extremely reliable however as there was slipping of the material from the grips during testing. Based on this data, TPU had the largest Young's Modulus (steepest slope), but we know that it also lacks elasticity which may not be great for our purposes.

SIERRA LOOSEN - Mar 07, 2026, 12:40 PM CST

Stress-Strain Curves by Material

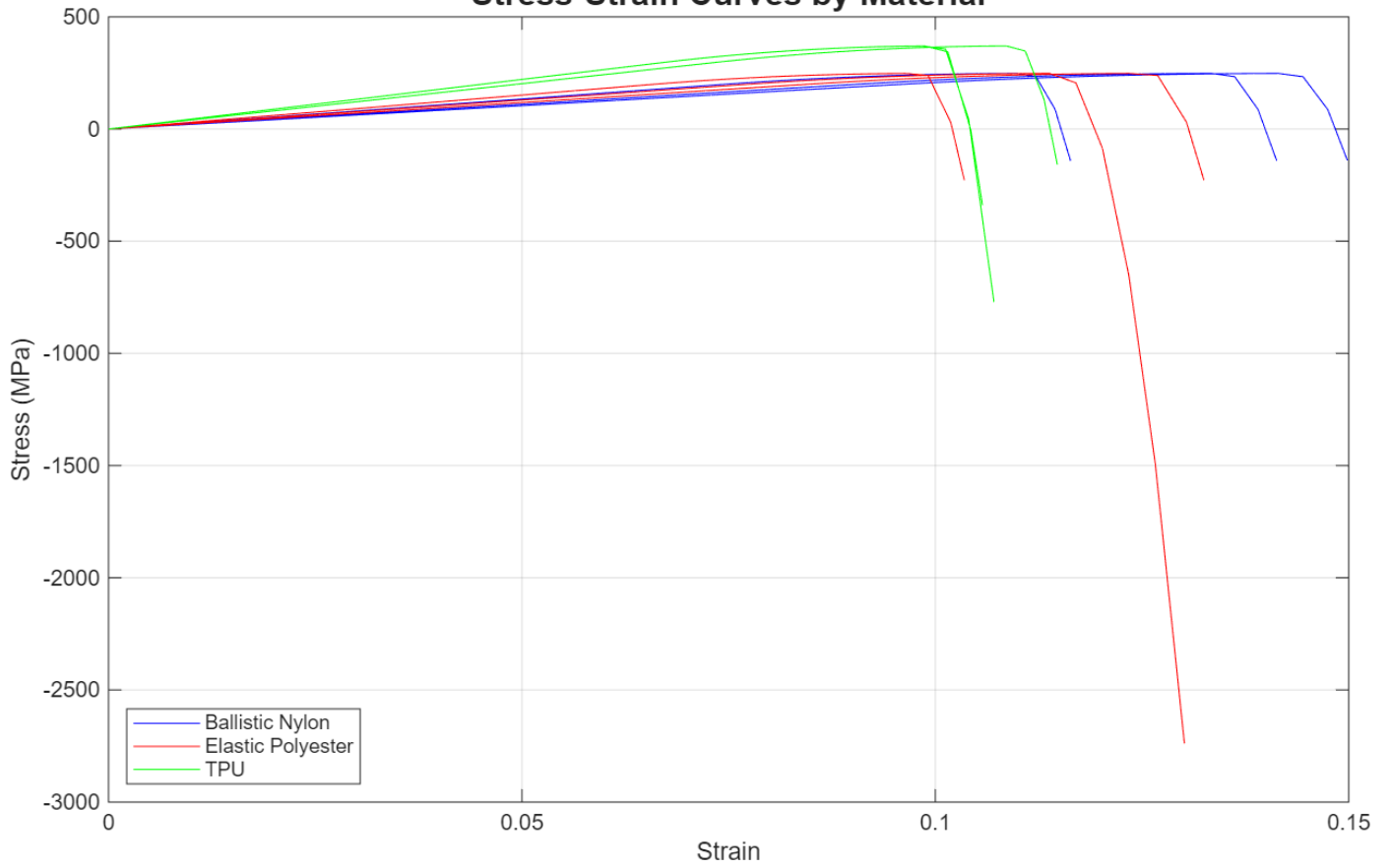

Ballistic Nylon

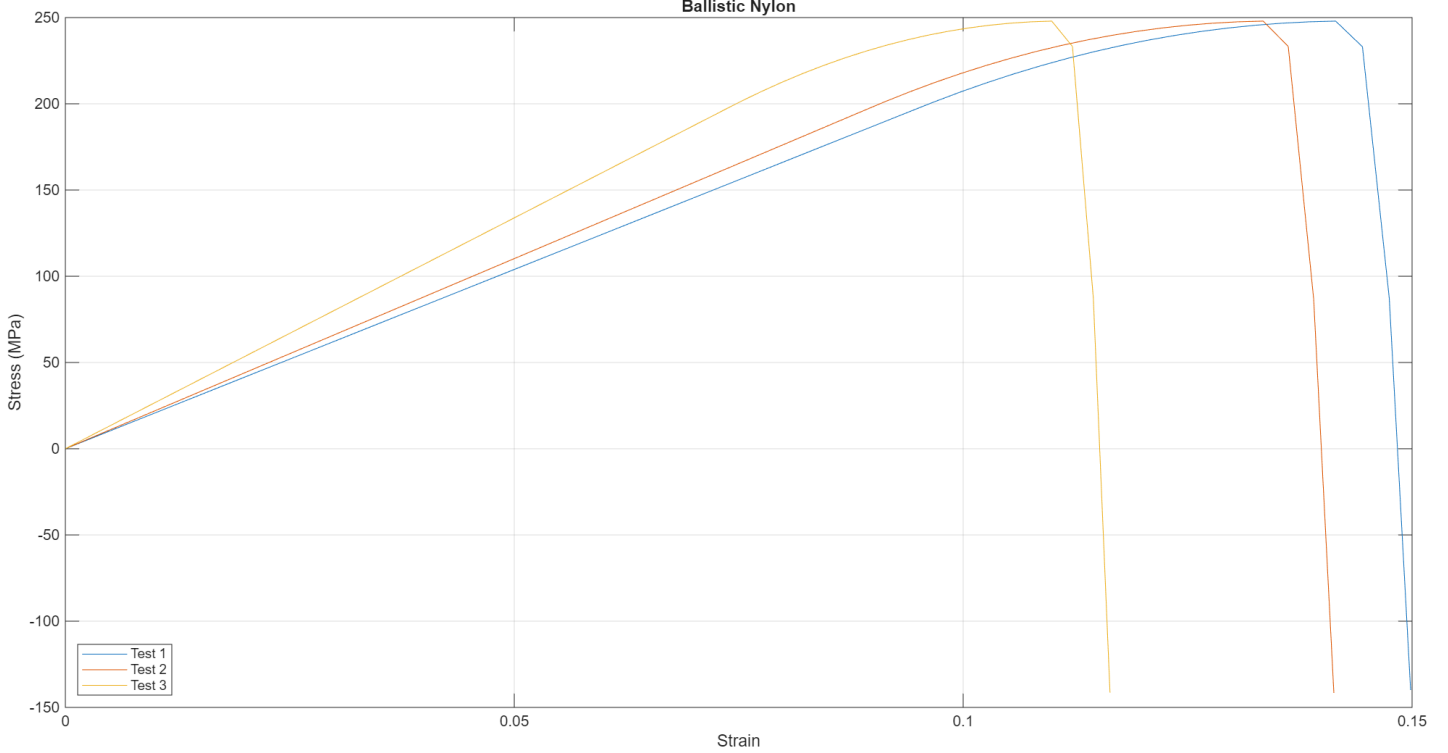

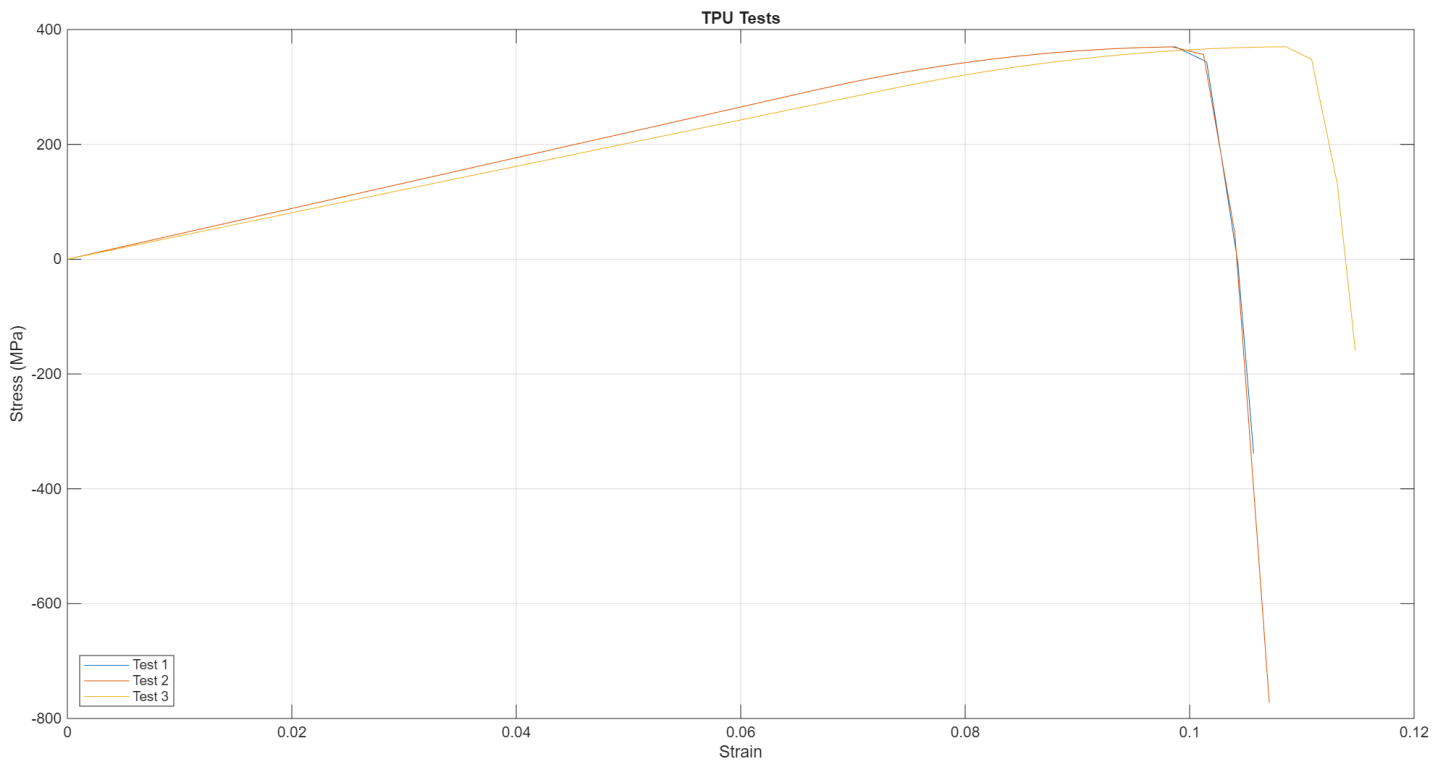
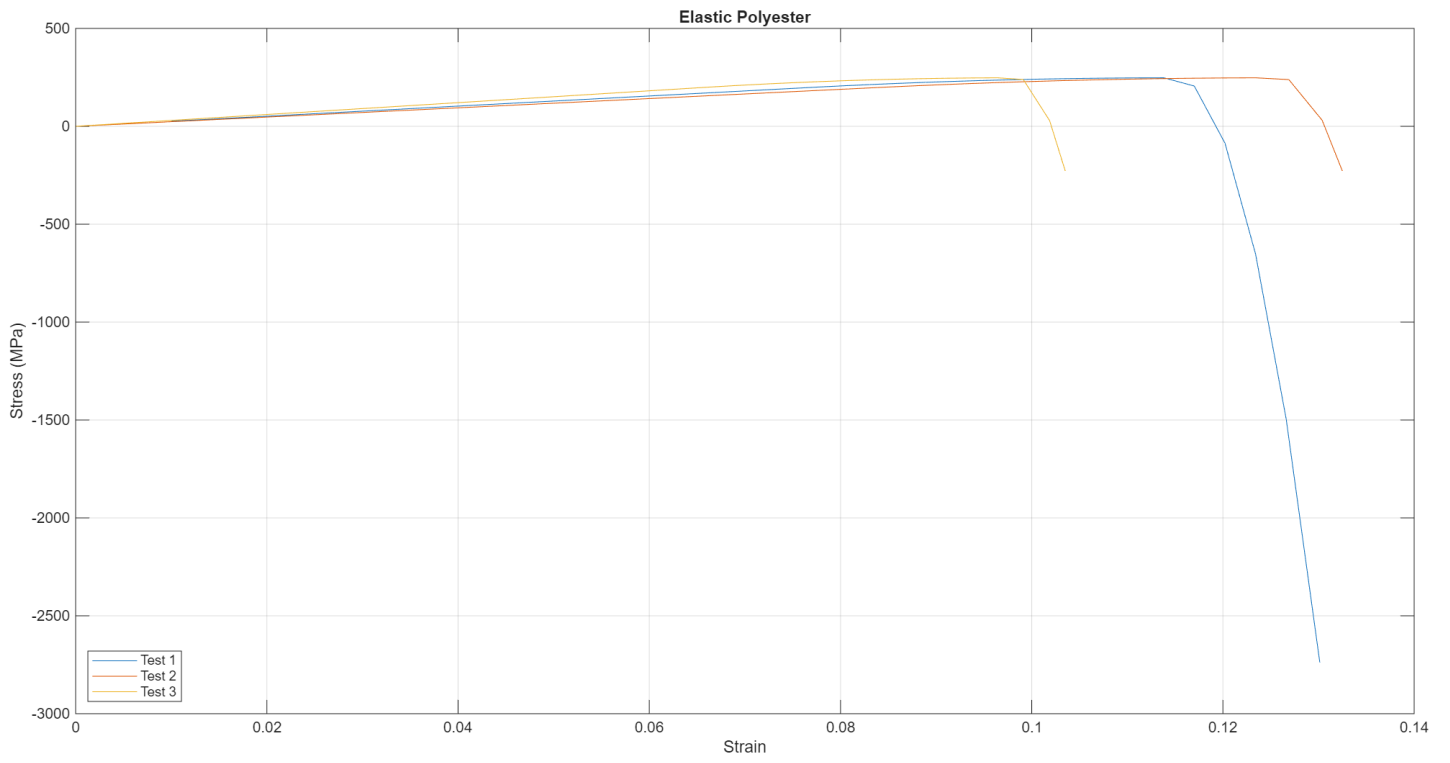

SIERRA LOOSEN - Mar 07, 2026, 12:40 PM CST

MATLAB Code

% Ballistic nylon tests

ballistic_1 = readmatrix("B1.txt");

```
displacement_ballistic_1 = ballistic_1(:, 1);  
load_ballistic_1 = ballistic_1(:, 2);  
time_ballistic_1 = ballistic_1(:, 3);  
area_ballistic_1 = 20.16125 %mm squared (the area of the cross section, width*thickness)  
guage_ballistic_1 = 83.82 % mm  
stress_ballistic_1 = load_ballistic_1 / area_ballistic_1;  
strain_ballistic_1 = displacement_ballistic_1 / guage_ballistic_1;
```

% Ballistic nylon test 2

```
ballistic_2 = readmatrix("BN2.txt");  
displacement_ballist_2 = ballistic_2(:, 1);  
load_ballistic_2 = ballistic_2(:, 2);  
time_ballistic_2 = ballistic_2(:, 3);  
area_ballistic_2 = 20.16125 % mm squared  
guage_ballistic_2 = 88.9 % mm  
stress_ballistic_2 = load_ballistic_2 / area_ballistic_2;  
strain_ballistic_2 = displacement_ballist_2 / guage_ballistic_2;
```

% Ballistic Nylon test 3

```
ballistic_3 = readmatrix("BN3.txt");  
displacement_ballistic_3 = ballistic_3(:, 1);  
load_ballistic_3 = ballistic_3(:, 2);  
time_ballistic_3 = ballistic_3(:, 3);  
area_ballistic_3 = 20.16125 % mm squared  
guage_ballistic_3 = 107.95 % mm  
stress_ballistic_3 = load_ballistic_3 / area_ballistic_3;  
strain_ballistic_3 = displacement_ballistic_3 / guage_ballistic_3;
```

```
figure(1);
```

```
plot(strain_ballistic_1, stress_ballistic_1, strain_ballistic_2, stress_ballistic_2, strain_ballistic_3, stress_ballistic_3);

legend("Test 1", "Test 2", "Test 3", "Location", "southwest");

title("Ballistic Nylon");

xlabel('Strain');

ylabel('Stress (MPa)');

grid on;

%% Elastic polyester tests

ep_1 = readmatrix("EP1.txt");

displacement_ep_1 = ep_1(:, 1);

load_ep_1 = ep_1(:, 2);

time_ep_1 = ep_1(:, 3);

area_ep_1 = 20.16125; % mm squared, assuming 1 in wide and 1/32 in thick

guage_ep_1 = 104.14; % mm

stress_ep_1 = load_ep_1 / area_ep_1;

strain_ep_1 = displacement_ep_1 / guage_ep_1;

% Elastic Polyester test 2

ep_2 = readmatrix("EP2.txt");

displacement_ep_2 = ep_2(:, 1);

load_ep_2 = ep_2(:, 2);

time_ep_2 = ep_2(:, 3);

area_ep_2 = 20.16125; % mm squared, assuming 1 in wide, 1/32 in thick

guage_ep_2 = 95.25; % mm

stress_ep_2 = load_ep_2 / area_ep_2;

strain_ep_2 = displacement_ep_2 / guage_ep_2;

% Elastic Polyester test 3

ep_3 = readmatrix("EP3.txt");

displacement_ep_3 = ep_3(:, 1);
```

```
load_ep_3 = ep_3(:, 2);

time_ep_3 = ep_3(:, 3);

area_ep_3 = 20.16125; % mm squared, assuming 1 in wide, 1/32 in thick

guage_ep_3 = 121.92; % mm

stress_ep_3 = load_ep_3 / area_ep_3;

strain_ep_3 = displacement_ep_3 / guage_ep_3;

figure(2);

plot(strain_ep_1, stress_ep_1, strain_ep_2, stress_ep_2, strain_ep_3, stress_ep_3);

legend("Test 1", "Test 2", "Test 3", "Location", "southwest");

title("Elastic Polyester");

xlabel('Strain');

ylabel('Stress (MPa)');

grid on;

hold on;

%% TPU tests

tpu_1 = readmatrix("TPU1.txt");

displacement_tpu_1 = tpu_1(:, 1);

load_tpu_1 = tpu_1(:, 2);

time_tpu_1 = tpu_1(:, 3);

area_tpu_1 = 13.5080375; % mm squared, 0.03125 in thick, 0.67 in wide

guage_tpu_1 = 119.38; % mm

stress_tpu_1 = load_tpu_1 / area_tpu_1;

strain_tpu_1 = displacement_tpu_1 / guage_tpu_1;

tpu_2 = readmatrix("TPU2.txt");

displacement_tpu_2 = tpu_2(:, 1);

load_tpu_2 = tpu_2(:, 2);

time_tpu_2 = tpu_2(:, 3);
```

```
area_tpu_2 = 13.5080375% mm squared
```

```
guage_tpu_2 = 119.38 % mm
```

```
stress_tpu_2 = load_tpu_2 / area_tpu_2;
```

```
strain_tpu_2 = displacement_tpu_2 / guage_tpu_2;
```

```
tpu_3 = readmatrix("TPU3.txt");
```

```
displacement_tpu_3 = tpu_3(:, 1);
```

```
load_tpu_3 = tpu_3(:, 2);
```

```
time_tpu_3 = tpu_3(:, 3);
```

```
area_tpu_3 = 13.5080375% mm squared
```

```
guage_tpu_3 = 109.22 % mm
```

```
stress_tpu_3 = load_tpu_3 / area_tpu_3;
```

```
strain_tpu_3 = displacement_tpu_3 / guage_tpu_3;
```

```
figure(3);
```

```
plot(strain_tpu_1, stress_tpu_1, strain_tpu_2, stress_tpu_2, strain_tpu_3, stress_tpu_3);
```

```
legend("Test 1", "Test 2", "Test 3", "Location", "southwest");
```

```
title("TPU Tests");
```

```
xlabel("Strain");
```

```
ylabel("Stress (MPa)");
```

```
grid on;
```

```
%% Comparing all data on 1 graph
```

```
figure(4);
```

```
% Plot all three materials
```

```
p1 = plot(strain_ballistic_1, stress_ballistic_1, 'b', ...
```

```
strain_ballistic_2, stress_ballistic_2, 'b', ...
```

```
strain_ballistic_3, stress_ballistic_3, 'b');
```

```
hold on;
```

```
p2 = plot(strain_ep_1, stress_ep_1, 'r', ...  
strain_ep_2, stress_ep_2, 'r', ...  
strain_ep_3, stress_ep_3, 'r');
```

```
p3 = plot(strain_tpu_1, stress_tpu_1, 'g', ...  
strain_tpu_2, stress_tpu_2, 'g', ...  
strain_tpu_3, stress_tpu_3, 'g');
```

```
% Legend using one representative line per material
```

```
legend([p1(1), p2(1), p3(1)], 'Ballistic Nylon', 'Elastic Polyester', 'TPU', ...  
'Location', 'southwest');
```

```
xlabel('Strain');
```

```
ylabel('Stress (MPa)');
```

```
title('Stress-Strain Curves by Material', 'FontSize', 15);
```

```
grid on;
```

```
box on;
```



04/20/2026 - Dorsiflexion and Stabilogram Testing Analysis

Alex Conover - Apr 27, 2026, 12:27 PM CDT

Title: Testing Analysis

Date: 4/20/2026

Content by: Alex Conover

Present: Alex and Sierra

Goals: Analyze the data from testing.

Content:

To see the data, follow this link to the drive, and view the 50 billion files we have:

https://drive.google.com/drive/folders/1GpkoddQL3__ZgCqAwWS-zz1Ub1xVclQC?usp=drive_link

Much of the analysis was crunched due to the poster presentation being on friday, but good analysis was done, and the dorsiflexion is significant!

Conclusions/action items:

See the poster and report for more information about testing.



Alex Conover - Jan 23, 2026, 12:12 PM CST

BME Design-Fall 2025 - Alex Conover
Complete Notebook
PDF Version generated by
Sean CAFFEY
on
Date: 10/20/25 @ 12:12 PM CST

Table of Contents

Project Information	2
Team/Project Information	2
Project Description	4
Team Schedule	5
Stow and tell - 1/13/1985	5
Team Meeting 1 - 09/09/2025	7
Team Meeting 2 - 09/14/2025	8
Team Meeting 3 - 09/21/2025	11
Team Meeting 4 - 09/28/2025	13
Team Meeting 5 - 10/05/2025	14
Team Meeting 6 - 10/12/2025	18
Team Meeting 7 - 10/20/2025	19
Team Meeting 8 - 10/27/2025	17
Team Meeting 9 - 11/03/2025	18
Team Meeting 10 - 11/10/2025	19
Team Meeting 11 - 11/20/2025	30
Team Meeting 12 - 12/01/2025	21
Client Meetings	22
09/15/2025 - Client Meeting 1	22
09/15/2025 - Client Meeting 1	28
10/15/2025 - Client Meeting 2	26
Advisor Meetings	30
09/12/2025 - Advisor Meeting 1	30
09/19/2025 - Advisor Meeting 2	30
09/26/2025 - Advisor Meeting 3	30
10/03/2025 - Advisor Meeting 4	31
10/10/2025 - Advisor Meeting 5	30
10/17/2025 - Advisor Meeting 6	34
11/03/2025 - Advisor Meeting 7	35
11/10/2025 - Advisor Meeting 8	36
11/17/2025 - Advisor Meeting 9	37
Design Processes	38
09/14/2025 - Team Brainstorm	38
09/24/2025 - 3D Printaway Design	41
10/16/2025 - 3D Print Design Meeting	44
Materials and Expenses	46
12/15/2025 - Final Expense Table	46
Fabrication	47
11/19/2025 - Final Fabrication Notes	48
Testing and Results	51
Protocols	51
09/14/2025 - FEA Testing	51
09/24/2025 - Stow Print Testing Protocol	54
10/19/2025 - MFG Testing Information	59

[Download](#)

2025_12_10_notebook_22139-compressed.pdf (6.24 MB)

Alex Conover - Jan 26, 2026, 2:27 PM CST

Alex Conover - Jan 26, 2026, 2:34 PM CST

Title: Fall 2025 Final Notebook

Date: 12/12/2025

Content by: Alex Conover

Present: Fall 2025 Team Members

Goals: Have a summary of the notebook from fall 2025 for research and reference purposes.

Content:

For convenience, the project was summarized by ChatGPT. The "learn from your information" mode has been turned off, so ChatGPT does not learn from your information, and will not share your information to the internet.

This project focused on the design, fabrication, and evaluation of an inconspicuous ankle-foot orthosis (AFO) intended for a teenage patient with Facioscapulohumeral Muscular Dystrophy (FSHD). The primary objective was to improve dorsiflexion during gait while maintaining medial-lateral ankle stability, comfort, and discretion—key concerns identified by the client and patient, who expressed dissatisfaction with traditional rigid AFOs due to bulkiness, discomfort, and social stigma. The device was required to support functional walking, accommodate daily activities such as horseback riding, and resemble an athletic brace rather than a medical device.

Building upon work from prior semesters, the team employed a structured, user-centered design process that included background research, client interviews, brainstorming, a weighted design matrix, and iterative prototyping. Three preliminary concepts were evaluated against criteria such as dorsiflexion support, comfort, durability, discreteness, and ease of use, leading to the selection of an inversion-prevention brace augmented with flexible dorsiflexion straps. Multiple design iterations addressed prior failure modes, including fracture near the malleolus and inadequate force transfer, through changes in geometry, material thickness, strap placement, and padding design.

Fabrication combined carbon-fiber reinforced PLA structural components with TPU and textile elements to balance stiffness and flexibility. Mechanical characterization was performed using tensile and repeated stress testing on an MTS system to evaluate candidate strap materials, while functional performance was assessed through force plate gait analysis and balance testing. Patient testing compared walking and standing trials with and without the brace, revealing improvements in foot clearance, heel strike behavior, and overall gait stability, particularly when worn with a shoe.

Overall, the final prototype demonstrated meaningful functional improvement over prior designs and standard orthoses while better meeting the patient's aesthetic and comfort needs. While some limitations remain—such as residual strap slippage and variability in quantitative gait metrics—the results support the feasibility of a low-profile, modular AFO for adolescents with progressive neuromuscular conditions. Future work includes refining strap retention, improving statistical power in gait analysis, and pursuing intellectual property protection to enable continued development beyond the academic setting.

Conclusions/action items:

If other analysis is necessary, then individual entries may be considered to further delve into the notebook and report.

 **Fall 2025 Final Report**

Alex Conover - Jan 27, 2026, 3:13 PM CST

Title: Executive summary of the Fall 2025 Final Report**Date:** 01/27/2026**Content by:** Alex Conover**Present:** Fall 2025 Team**Goals:** Further understand what is going on within the final report, and learn about any extra information that may need to be included.**Content:**

This final report documents the design, fabrication, and evaluation of a custom ankle–foot orthosis developed for a teenage patient with FSHD who experiences foot drop, ankle inversion, and gait instability. Building on multiple prior semesters of development, the project aimed to deliver a discreet, comfortable, and functional orthotic solution that the patient would consistently wear in daily life, including at school and during horseback riding.

The finalized AFO integrates carbon fiber–reinforced PLA inversion supports, a low-profile elastic dorsiflexion strap, adjustable ballistic nylon fastening, and dual-layer breathable padding. The design balances rigidity for mediolateral ankle stability with flexibility to allow natural gait mechanics. Fabrication leveraged patient-specific 3D scanning and additive manufacturing to ensure a precise fit while maintaining low cost and rapid iteration capability.

Validation testing included comfort surveys, force plate gait analysis, stabilogram assessment of postural sway, and mechanical testing of structural components. Results indicated reduced discrepancies between heel-strike and toe-off forces, improved mediolateral stability during stance, and increased patient-reported comfort compared to earlier prototypes and no-brace conditions. Although statistical significance was limited by a single-participant sample, observed trends and effect size analyses suggested meaningful functional improvements without adverse gait effects.

The report concludes that the final design successfully meets the core functional and aesthetic goals established in the PDS, demonstrating a viable custom orthotic solution for adolescents with neuromuscular disorders. Recommendations for future work include material refinement, improved strap retention, expanded clinical testing, and exploration of scalability for broader patient populations.

Conclusions/action items:

Continue to refine the brace and learn as much as we can from the final report.

Alex Conover - Jan 27, 2026, 3:13 PM CST



Team Name:
AFO for Theo

Team Members:
Alex Crooner (Team Leader)
Avery Lopez (Communications)
Adam Singleton (Co-EPAG)
Celia Oshkovec (Co-EPAG)
Clare Munkel (MSAC)
Sean Curry (EPAG)

Client:
Debbie Eggleston

Advisor:
Debra Josie Williams - University of Wisconsin-Madison

December 10, 2025

1

[Download](#)

AFO_for_Team_Final_Report_-_12_10_2025.pdf (14.4 MB)

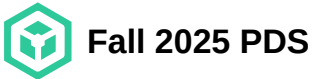

Alex Conover - Jan 27, 2026, 3:01 PM CST

Title: Fall 2025 PDS Executive Summary**Date:** 01/27/2026**Content by:** Alex Conover**Present:** N/A**Goals:** Summarize the PDS to understand the design specifications of the last semester.**Content:**

This Product Design Specification outlines the functional, mechanical, and user-centered requirements for a custom ankle-foot orthosis designed for a teenage patient with Facioscapulohumeral Muscular Dystrophy (FSHD). The primary objective of the device is to assist ankle dorsiflexion during gait, limit excessive inversion, and improve overall walking safety while remaining discreet, lightweight, and compatible with standard footwear. Special emphasis is placed on minimizing social stigma by creating a low-profile brace that resembles a common athletic support rather than a medical device.

The PDS defines detailed performance targets, including allowable ankle range of motion, resistive torque requirements during plantarflexion, inversion limits, and structural load capacity based on patient body weight and gait forces. Material constraints prioritize strength-to-weight ratio, durability under cyclic loading, breathability, and biocompatibility, with fiberglass, polymer composites, and flexible textiles identified as suitable candidates. The document also establishes dimensional requirements tailored to the patient's anatomy and outlines safety considerations related to skin contact, circulation, and emergency removal.

In addition, the PDS addresses regulatory classification, applicable standards, expected service life, operating environment, and economic considerations. Competing orthotic designs are reviewed to contextualize design tradeoffs and justify the need for a custom, discreet solution. Overall, the PDS serves as a comprehensive framework guiding design decisions, fabrication methods, and validation testing to ensure the final device meets both clinical performance goals and the patient's personal preferences.

Conclusions/action items:

Continue to optimize and refine the PDS to best fit the qualifications of our client.

Alex Conover - Jan 27, 2026, 3:14 PM CST



Inconspicuous Ankle Foot Orthosis (AFO) for teen

PROJECT DESIGN SPECIFICATIONS (PDS)

Team Name:
Team: AFOTeam Members:
Alex Conover (Team Leader)

Clair Mitchell (BSAC)
Betsy Jones (Communicator)
Crista D'Alonzo (Co-SPAG)
Albi Stephens (Co-SPAG)
Sara Corry (SPAG)

Client:
Debbie Eggleson

Advisor:
Doctor Justin Williams, University of Wisconsin - Madison

December 9th, 2025

[Download](#)

Product_Design_Specifications_-_AFO_for_Teen.pdf (366 kB)



01/27/2026 - FSHD 1 Research

Alex Conover - Jan 27, 2026, 4:16 PM CST

Title: FSHD 1 Research - Understanding the Complexity

Date: 01/27/2026

Content by: Alex Conover

Present: N/A

Goals: Understand more about FSHD, the disease that our client has.

Content:

Facioscapulohumeral Muscular Dystrophy (FSHD) is a rare, progressive neuromuscular disorder characterized by skeletal muscle weakness and degeneration. As seen in an article by D. Megalizzi, here are some of the most typical expressions of the disease, as well as causes and symptoms.

1. Muscle involvement typically begins in the face, shoulders, and upper arms, but often progresses to the lower limbs, contributing to gait impairment and foot drop.
2. FSHD is most commonly caused by abnormal expression of the DUX4 gene, which is normally silenced in healthy adult muscle tissue.
3. Disease onset and severity vary widely between individuals, even among patients with similar genetic alterations.
4. Epigenetic changes, particularly reduced DNA methylation in the D4Z4 region of chromosome 4, play a critical role in enabling DUX4 expression.
5. Aberrant DUX4 activity leads to muscle cell toxicity, impaired regeneration, and increased susceptibility to fatigue and injury.
6. FSHD affects both proximal and distal muscle groups, which can disrupt normal gait mechanics and joint stability.
7. Progressive ankle dorsiflexor weakness commonly results in foot drop, increasing fall risk, and functional limitations.
8. There is currently no cure for FSHD, and treatment focuses on symptom management, mobility support, and quality-of-life improvement.
9. Orthotic interventions, such as ankle-foot orthoses, play an important role in mitigating functional deficits caused by lower-limb muscle weakness.

After further thought with my basic level biology and genetics (hooray for bio 101), I had the thought of "can FSHD be cured with gene editing, early on in development, perhaps hypermethylation?", and came across some results:

- Gene editing and epigenetic modulation show real potential to reduce or silence DUX4 expression, which is the key toxic driver in FSHD.

- This approach *targets the root cause* rather than downstream symptoms.
- However, fully curing FSHD will require solving delivery, safety, and reversal of established pathology challenges.
- Early clinical efforts indicate *hopeful progress toward disease-modifying therapy*, but the question of a complete cure remains open and under investigation.

Per the research article by A. Sasala, initial trials have begun to assess whether this gene-editing technology can alleviate symptoms and prevent further damage in patients.

- August 2025 announcement: first patient dosed, no results yet — trial launched.
- January 2026 update: early data from a small number of participants show favorable safety and promising early functional improvements compared to natural history controls, but no definitive efficacy outcomes have been published.
- **EPI-321 is delivered via a clinically validated AAV vector (AAVrh74)** that has been used in other muscle gene therapies, suggesting it can effectively reach skeletal muscle cells and has an existing safety track record.
- The therapy is designed not to cut DNA but to **epigenetically silence DUX4 by increasing methylation near the gene**, which could provide *durable repression* of the pathogenic expression underlying FSHD.
- This is a **single-dose treatment** aimed at producing long-lasting effects — the idea being that once methylation patterns are restored, muscle cells may maintain normal gene repression for their lifetime.
- The study is a **Phase 1/2 open-label, dose-escalation trial** designed to evaluate safety and early signs of efficacy over a long follow-up (up to ~5 years), though early results are expected sooner.
- A well-matched **natural history comparator cohort (ReSolve study) is being used** in early analyses, which strengthens the context for interpreting functional and strength measures from the first participants.
- The therapy has received **multiple regulatory designations**—FDA Fast Track, Rare Pediatric Disease, and Orphan Drug—indicating regulatory recognition of its potential and the unmet medical need in FSHD.
- Epicrispr's platform (Gene Expression Modulation System or GEMS) represents an approach where gene expression can be adjusted without permanent cuts to the genome, potentially reducing safety risks compared with nuclease-based editing.

As previously concluded, FSHD is a terrible disease to be afflicted with, and

References:

[1] D. Megalizzi *et al.*, “Deciphering the Complexity of FSHD: A Multimodal Approach as a Model for Rare Disorders,” *International Journal of Molecular Sciences*, vol. 25, no. 20, p. 10949, Jan. 2024, doi: [10.3390/ijms252010949](https://doi.org/10.3390/ijms252010949).

[2] A. Sasala, “Epicrispr Biotechnologies Doses First Patient in First-in-Human Clinical Trial of EPI-321 for Facioscapulohumeral Muscular Dystrophy - FSHD Society.” Accessed: Jan. 27, 2026. [Online]. Available: <https://www.fshdsociety.org/2025/08/06/epicrispr-8-6-25/>

Conclusions/action items:

Continue to research for this project, diving further into various topics to prevent the same kind of research to be done over and over again. Finish at least 2, possibly 4 entries by this thursday.



01/27/2026 - Gait Cycle Research

Alex Conover - Jan 27, 2026, 4:40 PM CST

Title: Gait and Walking Analysis Research

Date: 01/27/2026

Content by: Alex Conover

Present: N/A

Goals: Understand the gait cycle, in walking and running, and understand how foot drop and other muscle weaknesses can affect the gait.

Content:

Notes on the gait cycles comparing walking and running mechanics:

Walking:

Overall structure

- One gait cycle is defined as heel strike to heel strike of the same foot.
- Walking always includes a stance phase and a swing phase, with periods of double support.
- Typical phase distribution:
 - Stance phase: ~60% of the cycle
 - Swing phase: ~40% of the cycle

Stance phase (≈60%)

- Begins at initial contact (heel strike).
- Foot transitions from heel to full contact while the limb accepts body weight.
- Includes loading response, mid-stance, and terminal stance.
- The ankle moves from slight dorsiflexion to plantarflexion, then back toward dorsiflexion.
- Plantarflexors act eccentrically early and concentrically at push-off.
- Ends at toe-off.

Swing phase (≈40%)

- Begins when the foot leaves the ground.
- Limb advances forward and prepares for the next contact.
- Requires adequate ankle dorsiflexion for toe clearance.

- Ends at the next heel strike.

Key biomechanical features

- Presence of double support (~20% of the cycle total).
- Lower peak ground reaction forces compared to running.
- More energy-efficient and mechanically stable than running.
- Highly dependent on ankle control for smooth transitions.

Running cycle:

Overall structure

- One running cycle is also defined as foot contact to next contact of the same foot.
- Running eliminates double support and introduces a flight phase.
- Phase distribution varies with speed, but typically:
 - Stance phase: ~30–40%
 - Swing + flight: ~60–70%

Stance phase

- Shorter and more forceful than in walking.
- Begins with foot strike (heel, midfoot, or forefoot depending on runner).
- Limb rapidly absorbs impact and stores elastic energy.
- Ankle, knee, and hip flex more than in walking.
- Ends with powerful push-off.

Flight phase

- Both feet are off the ground simultaneously.
- Unique to running and sprinting.
- Requires higher muscle activation and balance control.

Key biomechanical features

- Much higher ground reaction forces than walking (often 2–3× body weight).
- Greater reliance on elastic energy storage in tendons (especially Achilles).
- Increased joint moments and loading rates.
- Reduced stability compared to walking.

Much of this was review from BME 315 (biomechanics) where we were constantly analyzing the data from walking and running, but some general review never hurts.

Understanding some of the AFO integration with walking and the gait in general, notes here:

- Normal walking relies on coordinated ankle plantarflexor activity to support body weight, generate forward propulsion, and initiate limb swing during late stance.
- The gastrocnemius and soleus muscles are the primary contributors to these functions, producing substantial ankle moments that directly influence gait efficiency.
- Weakness or impaired activation of these muscles disrupts ankle moment generation, leading to altered gait mechanics, reduced push-off, and compromised foot clearance.
- Ankle–foot orthoses (AFOs) introduce an external mechanical moment at the ankle joint that interacts with the user's biological joint moments during gait.
- Experimental gait analyses have directly quantified the magnitude and timing of AFO-generated moments throughout the stance phase.
- Increasing plantarflexion resistance in an articulated AFO reduces excessive ankle plantarflexion during early stance and improves control of foot position.
- Changes in ankle resistance affect not only ankle kinematics but also knee joint motion and loading due to biomechanical coupling between joints.
- Higher AFO resistive moments can increase knee flexion or alter knee moments, indicating potential tradeoffs between ankle control and proximal joint mechanics.
- Optimal AFO performance depends on appropriate tuning of resistive stiffness to support dorsiflexion while minimizing unintended compensatory movements.
- These findings highlight the importance of balancing stability and mobility when designing AFOs for individuals with neuromuscular impairments.

References:

- [1] J. Perry and J. M. Burnfield, *Gait Analysis: Normal and Pathological Function*, 2nd ed. Thorofare, NJ, USA: SLACK Incorporated, 2010.
- [2] R. R. Neptune, S. A. Kautz, and F. E. Zajac, "Contributions of the individual ankle plantar flexors to support, forward progression and swing initiation during walking," *J Biomech*, vol. 34, no. 11, pp. 1387–1398, Nov. 2001, doi: [10.1016/s0021-9290\(01\)00105-1](https://doi.org/10.1016/s0021-9290(01)00105-1).
- [3] T. Kobayashi, M. S. Orendurff, M. L. Singer, F. Gao, and K. B. Foreman, "Contribution of ankle-foot orthosis moment in regulating ankle and knee motions during gait in individuals post-stroke," *Clin Biomech (Bristol)*, vol. 45, pp. 9–13, Jun. 2017, doi: [10.1016/j.clinbiomech.2017.04.002](https://doi.org/10.1016/j.clinbiomech.2017.04.002).
- [4] T. Kobayashi, M. L. Singer, M. S. Orendurff, F. Gao, W. K. Daly, and K. B. Foreman, "The effect of changing plantarflexion resistive moment of an articulated ankle-foot orthosis on ankle and knee joint angles and moments while walking in patients post stroke," *Clin Biomech (Bristol)*, vol. 30, no. 8, pp. 775–780, Oct. 2015, doi: [10.1016/j.clinbiomech.2015.06.014](https://doi.org/10.1016/j.clinbiomech.2015.06.014).

Conclusions/action items:

Great review of running and walking mechanics, and then how both are affected by using an AFO. In our designs, we should be sure to aim to fix foot drop to prevent any injuries during walking or running, and then provide a stable enough support to stabilize the gait of the patient.



01/27/2026 - Materials Research

Alex Conover - Jan 27, 2026, 5:15 PM CST

Title: Materials Research

Date: 01/27/2026

Content by: Alex Conover

Present: N/A

Goals: Understand a little bit more about what kind of materials we could use / reinforce that the ones we've picked work well.

Content:

Through research about materials for both aspects of the brace, dorsiflexion, and preventing eversion/inversion.

- Experimental studies show that 3D-printed polymers such as PLA exhibit strong mechanical anisotropy, with significantly lower strength and stiffness in the build (Z) direction due to weak interlayer bonding.
- This finding directly impacts AFO design, as load-bearing components must be printed with primary stress directions aligned in-plane with filament paths to avoid premature failure.
- Tensile and failure analyses demonstrate that interlayer delamination, rather than material yielding, is the dominant failure mode in FDM-printed PLA, reinforcing the need for conservative safety factors in orthotic components.
- Research on fiber-reinforced polymer composites fabricated through additive manufacturing shows substantial improvements in flexural strength, stiffness, and fatigue resistance compared to unreinforced polymers.
- These improvements are especially relevant to AFOs, which experience repetitive cyclic loading during gait, making fatigue performance a critical design consideration.
- Studies indicate that fiber alignment and reinforcement placement significantly affect mechanical performance, supporting the use of carbon-fiber-reinforced PLA for inversion-resisting structural elements in this project.
- Flexural fatigue testing of reinforced composites demonstrates slower stiffness degradation over time, which aligns with the project's goal of creating a durable brace suitable for daily use.
- The research supports the design decision to separate rigid structural components from flexible elements, allowing stiffness where stability is needed and compliance where motion is required.
- Additive manufacturing enables patient-specific geometry while maintaining adequate mechanical performance when fabrication parameters are carefully controlled, which is essential for custom orthotic fit.
- Overall, these studies justify the project's focus on print orientation, material selection, and reinforcement strategies to ensure the AFO provides sufficient support, durability, and safety under real-world use.

Also, some preliminary research for using carbon fiber:

Using carbon fiber for the medial and lateral support components of the AFO could be beneficial because it offers a higher stiffness-to-weight ratio and improved fatigue resistance compared to 3D-printed polymers, allowing greater inversion and eversion control with thinner, lighter structures. This could enhance durability under the repetitive loading experienced during gait while maintaining a low-profile design. However, pure carbon fiber introduces increased fabrication complexity, higher cost, slower iteration, and greater risk of comfort issues if edge finishing and padding are not carefully managed. Given the need for patient-specific geometry and iterative refinement, a hybrid approach—such as reinforcing printed components with carbon fiber in high-stress regions—may provide a practical balance between mechanical performance, manufacturability, and user comfort for this project.

The team knows that manufacturing with carbon fiber would be time-consuming and difficult, but may be willing to try for a finalized product. It may not be necessary at this point to craft the device out of carbon fiber, but it may prevent some of the early wear and tear that could be present with the reinforced PLA. The team would have to work in the automotive lab on campus, as that is the only place where UW students can get certified to work with carbon fiber, as well as use the stuff in general.

References:

[1] A. R. Torrado and D. A. Roberson, "Failure Analysis and Anisotropy Evaluation of 3D-Printed Tensile Test Specimens of Different Geometries and Print Raster Patterns," *J Fail. Anal. and Preven.*, vol. 16, no. 1, pp. 154–164, Feb. 2016, doi: [10.1007/s11668-016-0067-4](https://doi.org/10.1007/s11668-016-0067-4).

[2] A. D. Pertuz-Comas, J. G. Díaz, O. J. Meneses-Duran, N. Y. Niño-Álvarez, and J. León-Becerra, "Flexural Fatigue in a Polymer Matrix Composite Material Reinforced with Continuous Kevlar Fibers Fabricated by Additive Manufacturing," *Polymers*, vol. 14, no. 17, p. 3586, Jan. 2022, doi: [10.3390/polym14173586](https://doi.org/10.3390/polym14173586).

Conclusions/action items:

Look into the automotive lab training for working with carbon fiber, and determine if the team wants to work with the material in general.

Continue to research materials and testing opportunities for our materials to determine what would best help support dorsiflexion in the design.



01/27/2026 - 3D Printing Research

Alex Conover - Jan 27, 2026, 9:54 PM CST

Title:

Date: 01/27/2026

Content by: Alex Conover

Present: N/A

Goals:

Content:

Materials and fabrication research for 3D printing AFO's (to confirm what we're already doing):

- **3D printing enables personalized orthosis geometry** based on patient-specific scans, improving fit and dimensional accuracy over traditional molding methods.
- **Fused deposition modeling (FDM) materials (e.g., PC-ABS, ULTEM)** can be used to create patient-specific AFOs, with measurable mechanical performance such as strain and rotational stiffness during gait.
- **Automated design and scanning workflows reduce fabrication time** and technical skill requirements, increasing reproducibility and easing iteration between prototypes.
- **Clinical testing of 3D-printed AFOs shows mechanical durability** (no cracks or stiffness change after use) and high patient satisfaction due to weight and comfort, supporting the viability of printed orthoses.
- **Biomechanical effects of AM-fabricated AFOs are observable**, as printed devices have distinct influences on ankle kinematics and can be tuned for stiffness and movement control.
- **3D-printed AFOs show potential advantages over traditional orthoses** in fit, aesthetics, and ability to customize function without extensive manual fabrication steps.
- Research supports the **use of computational modeling alongside experimental testing** to predict loading and optimize material usage in AFO design.
- These studies collectively justify your project's emphasis on **custom geometry, material selection, and fabrication control** to achieve effective orthotic function.

This research supports our methods, as we are using a mold of the patients' scans to design the brace, creating the maximum amount of mechanical performance, as the brace is fitted to the patient. The 3D printing allows the device to be incredibly easy to use, lightweight, comfortable, and easily customizable. The customizability that comes with 3D printing might warrant staying with 3D printing, regardless of our ideas for carbon fiber. We hypothetically could use the current 3D printed model to create a mold for the carbon fiber, but the shape is incredibly organic, and might not be feasible with carbon fiber.

References:

[1] R. K. Chen, L. Chen, B. Tai, Y. Wang, A. Shih, and J. Wensman, "Additive manufacturing of personalized ankle-foot orthosis," *Transactions of the North American Manufacturing Research Institution of SME*, vol. 42, pp. 381–389, Jan.

2014.

[2] "Ankle-Foot Orthosis Made by 3D Printing Technique and Automated Design Software - Cha - 2017 - Applied Bionics and Biomechanics - Wiley Online Library." Accessed: Jan. 27, 2026. [Online]. Available: <https://onlinelibrary-wiley-com.ezproxy.library.wisc.edu/doi/10.1155/2017/9610468>

[3] S. Telfer, J. Pallari, J. Munguia, K. Dalgarno, M. McGeough, and J. Woodburn, "Embracing additive manufacture: implications for foot and ankle orthosis design," *BMC Musculoskelet Disord*, vol. 13, p. 84, May 2012, doi: [10.1186/1471-2474-13-84](https://doi.org/10.1186/1471-2474-13-84).

[4] E. Wojciechowski *et al.*, "Feasibility of designing, manufacturing and delivering 3D printed ankle-foot orthoses: a systematic review," *J Foot Ankle Res*, vol. 12, p. 11, Feb. 2019, doi: [10.1186/s13047-019-0321-6](https://doi.org/10.1186/s13047-019-0321-6).

Conclusions/action items:

The team can work with these 3D printed materials, especially if the lifespan of the product is longer than expected, and fits better overall than that of a real AFO. This research confirms that we can continue to work with these elements, as we've tested them before.



02/10/2026 - Carbon Fiber Types and Responses

Alex Conover - Feb 10, 2026, 11:00 PM CST

Title: Carbon Fiber, Types and Responses

Date: 02/10/2026

Content by: Alex Conover

Present: N/A

Goals: Learn more about the manufacturing technique while using carbon fiber.

Content:

Carbon Fiber has exceptional biocompatibility [1]

- Article focuses on LTI carbon (pyrolytic carbon type), which is known for its biocompatibility
- carbon surfaces exhibit excellent blood compatibility (don't trigger reactions from the body's immune system (430 reference))
- more suited to long-term contact with living tissues and fluids (internal devices)

Carbon Fiber also has great resistance to wear and fatigue [1]

- high resistance under cyclic stress (essential property for implants under mechanical load)
- ideal/appealing for load-bearing biomedical components
- The higher durability helps mitigate the risk associated with weakening materials, shedding particles or toxic metals into the bloodstream/tissues.

Carbon Types [1]:

- Pyrolytic carbon: produced at high temperature, has a highly controlled microstructure
- Dense isotropic carbons: uniform properties in all directions
- Fiber-reinforced carbons: used as structural components in composite devices

Biological Interactions [1]:

General biological behavior of carbon materials:

- minimal adverse tissue reactions (less inflammatory responses, encapsulated by organized tissue rather than chaotic scarring)
- protein adsorption: carbon reduced unwanted platelet activation (preventing clotting)
- Surface adaptation: modifying the surface (coatings, texture) can further improve cell attachment and integration.
 - Makes CF a good candidate for heart valves and bone prostheses.

Influence, Legacy, etc [1]

This is in fact an old paper...

- referenced in many more recent studies

- helped inspire further composite and engineered carbon materials research, specifically looking at structural biomedical applications.

References:

[1] J. C. Bokros, "Carbon biomedical devices," *Carbon*, vol. 15, no. 6, pp. 353–371, Jan. 1977, doi: [10.1016/0008-6223\(77\)90324-4](https://doi.org/10.1016/0008-6223(77)90324-4).

Conclusions/action items:

Biomaterials research has been ongoing for a long time, and even back in the 70s we were looking for answers on how to put something into the body that shouldn't be there. Maybe this is why Wolverine is able to have adamantium on his skeleton. His healing factor is strong enough that the process in which the metal would be broken down doesn't happen, and the cells in his body are constantly replaced if they do get affected by metal leeching off of his bones.

This is also a good review for BME 430 (we have an exam next week and I'm scared), a lot of this exam will be about foreign body reactions and protein adsorption, both of which were mentioned in this article.



01/27/2026 - Competing AFO Research

Alex Conover - Jan 27, 2026, 10:06 PM CST

Title: Competing AFO Research

Date: 01/27/2026

Content by: Alex Conover

Present: N/A

Goals: Understand more about the types of AFO's that exist in the spectrum of AFO's.

Content:

Competing AFO Designs - Evidence from Research

- **AFO design categories:** AFOs are generally grouped into passive (fixed or articulated), semi-active (adaptive impedance/dampers), and active/robotic systems with actuators; each category has distinct mechanical goals and trade-offs.
- **Passive AFOs:** Traditional passive designs use mechanical elements (springs, hinges, dampers) to control motion and resist foot drop; they are simple and lightweight but do not actively generate torque.
- **Semi-active adaptive orthoses:** Devices with adaptive damping or variable stiffness elements can respond to gait phase, improving support and comfort without full actuation.
- **Actuated/Active AFOs:** Active orthotic systems use external power (electric, pneumatic, hydraulic) to apply controlled dorsiflexion or plantarflexion torque, offering dynamic support tailored to user needs.
- **Articulated support mechanisms:** Designs like the **ADJUST AFO** employ separate leaf-spring hinges to independently control plantarflexion and dorsiflexion stiffness, maintaining more normal ankle range of motion during gait.
- **Clinical effects vary by design:** Systematic reviews show that elastic and circular AFOs can improve dorsiflexion during swing, while dorsal orthoses benefit push-off moments and walking efficiency in plantarflexor weakness.
- **Design limitations:** Many existing AFOs restrict ankle range of motion which can limit activities requiring flexible gait patterns (e.g., stairs), highlighting the ongoing need for designs that balance control with mobility.
- **Robotic/advanced systems:** Research in rehabilitation robotics demonstrates the potential of powered AFOs and exoskeletons to generate needed torque profiles via actuators, improving gait mechanics beyond passive support.
- **Journal representation:** *Journal of Prosthetics and Orthotics* and *Prosthetics and Orthotics International* publish clinical and mechanical studies on AFO impacts, while *IEEE Transactions on Neural Systems and Rehabilitation Engineering* includes advanced orthotic control and adaptive designs.

- **Design trends:** The literature reflects a shift from rigid, static braces toward orthoses that adapt to user biomechanics, suggesting a broader range of design alternatives to benchmark against for your project.

References:

- [1] D. van der Wilk *et al.*, “Development of an Ankle-Foot Orthosis That Provides Support for Flaccid Paretic Plantarflexor and Dorsiflexor Muscles,” *IEEE Trans Neural Syst Rehabil Eng*, vol. 26, no. 5, pp. 1036–1045, May 2018, doi: [10.1109/TNSRE.2018.2818820](https://doi.org/10.1109/TNSRE.2018.2818820).
- [2] D. van der Wilk, P. U. Dijkstra, K. Postema, G. J. Verkerke, and J. M. Hijmans, “Effects of ankle foot orthoses on body functions and activities in people with floppy paretic ankle muscles: a systematic review,” *Clinical Biomechanics*, vol. 30, no. 10, pp. 1009–1025, Dec. 2015, doi: [10.1016/j.clinbiomech.2015.09.013](https://doi.org/10.1016/j.clinbiomech.2015.09.013).
- [3] M. Alam, I. A. Choudhury, and A. B. Mamat, “Mechanism and Design Analysis of Articulated Ankle Foot Orthoses for Drop-Foot,” *ScientificWorldJournal*, vol. 2014, p. 867869, 2014, doi: [10.1155/2014/867869](https://doi.org/10.1155/2014/867869).
- [4] C. Zhou, Z. Yang, K. Li, and X. Ye, “Research and Development of Ankle–Foot Orthoses: A Review,” *Sensors (Basel)*, vol. 22, no. 17, p. 6596, Sep. 2022, doi: [10.3390/s22176596](https://doi.org/10.3390/s22176596).

Conclusions/action items:

The different types of AFO's are all more cumbersome than what we have designed, minus the passive AFO, but even that can be uncomfortable and foreign, especially for a 16 year old girl. The method of creating a brace similar to an athletic brace creates the least amount of abrasiveness, the most amount of comfort, while still attempting to give the support one needs to walk normally.



01/27/2026 - Standards Research

Alex Conover - Jan 27, 2026, 10:13 PM CST

Title: Standards Research

Date: 01/27/2026

Content by: Alex Conover

Present: N/A

Goals: Figure out what patents and standards exist already so we can follow them throughout the process of creating our medical device.

Content:

Standards & Regulatory Resources

- **ISO 22675 – Testing of Ankle-Foot Devices and Foot Units**

Specifies standardized **cyclic and static test procedures** to evaluate the strength, durability, and service life of ankle-foot devices under simulated real-world loading conditions (e.g., heel strike to toe-off). These tests help verify whether a device can withstand repeated walking loads and static loads without structural failure [1].

- **ISO 10328 – Structural Testing of Lower-Limb Prostheses**

Defines **static and cyclic strength test methods** for structural components of lower-limb prostheses, including ankle-foot devices. The test configurations simulate compound loads experienced during normal walking stance and assess structural integrity, fatigue resistance, and safety [2].

- **FDA Recognized Standards – Medical Devices (incl. ISO 10328/22675)**

The U.S. Food and Drug Administration lists certain internationally recognized standards that can be used to demonstrate conformity with performance and safety requirements for medical devices, including lower-limb prosthetic and orthotic components. Manufacturers can use compliance with these standards in regulatory submissions to show device robustness and reliability [3].

How these standards relate to our project:

- ISO 22675 defines realistic cyclic and static tests that simulate walking loads on ankle-foot devices to assess strength and durability.
- ISO 22675 includes test ranges and loading profiles tied to stance-phase mechanics, ensuring devices are evaluated under conditions similar to real gait.
- ISO 10328 provides structural test methods for static and fatigue loads on complete lower-limb prostheses and components, including AFOs, informing strength requirements.
- Static and cyclic tests in ISO 10328 assess worst-case loading scenarios, helping designers anticipate potential failure modes from repeated gait cycles.
- FDA recognition of these standards means compliance can support regulatory submissions by demonstrating that your device meets widely accepted performance benchmarks.

- Using these standards in design validation improves confidence that an AFO will withstand long-term use without structural failure.

References:

[1] "ISO 22675:2024," ISO. Accessed: Jan. 27, 2026. [Online]. Available: <https://www.iso.org/standard/79620.html>

[2] "ISO 10328:2016," ISO. Accessed: Jan. 27, 2026. [Online]. Available: <https://www.iso.org/standard/70205.html>

[3] "Recognized Consensus Standards: Medical Devices." Accessed: Jan. 27, 2026. [Online]. Available: https://www.accessdata.fda.gov/scripts/cdrh/cfdocs/cfStandards/detail.cfm?standard__identification_no=42373&utm_source=chatgpt.com

Conclusions/action items:

We can continue to add to our device, and then, because we didn't get our patent from last semester, we can continue working towards that as an ultimate goal. However, the true main goal is to provide the patient with a device that they like to use, and has quantifiable results.



01/27/2026 - Patents Research

Alex Conover - Jan 27, 2026, 10:32 PM CST

Title: Existing Patents Research

Date: 01/27/2026

Content by: Alex Conover

Present: N/A

Goals: Understand more about the patents that exist, and figure out what may or may not be the reason we were denied a patent.

Content:

Patent Summaries:

1) Adjustable Dynamic Ankle Brace / Strut (WO2025222118A1)

- **What it covers:** An orthopedic brace with a **leg cuff, footplate, and adjustable strut** linking them. The strut's stiffness and bending location can be changed, allowing adaptation to different activity levels and terrain.
- **Relevance:** This patent illustrates *mechanically tunable stiffness* in AFOs — a concept that parallels design goals where you might want **variable support or adaptability** rather than a rigid, one-setting brace [1].

2) Ankle-Foot Orthosis Fixed to Shoe (US8904674B2)

- **What it covers:** A design for an AFO that is **structurally attached to a shoe's sole and upper**, with a continuous horizontal and vertical portion that provides support while trying to maintain gait mechanics.
- **Relevance:** Demonstrates *integrated brace–shoe systems* and highlights strategies for anchoring AFOs and distributing forces — important when comparing attachment strategies vs. your strap-based design [2].

3) Footplate with Energy Storage & Return (US7270644B2)

- **What it covers:** An orthotic footplate with *layered stiffness profiles* that **stores energy during stance flexion and releases it at toe-off**, aiding propulsion and stability.
- **Relevance:** This is a good example of *energy-storage mechanisms* in orthoses — conceptually similar to designs like *energy-storage AFOs* and argues for strategically designed flexures, which might inspire your dorsiflexion assistance mechanics [3].

These are all existing patents for the AFO's that exist already. Our device matches multiple descriptions, so it makes sense as to why we were denied a patent last fall.

References:

[1] J. E. Sanders, J. L. Garbini, M. WEISSINGER, and A. KROUT, "Adjustable dynamic ankle foot orthosis," WO2025222118A1, Oct. 23, 2025 Accessed: Jan. 27, 2026. [Online]. Available: <https://patents.google.com/patent/WO2025222118A1/en>

[2] N. Schwartz, "Ankle-foot orthosis," US8904674B2, Dec. 09, 2014 Accessed: Jan. 27, 2026. [Online]. Available: <https://patents.google.com/patent/US8904674B2/en>

[3] A. T. Ingimundarson, "Ankle-foot orthosis having an orthotic footplate," US7270644B2, Sep. 18, 2007 Accessed: Jan. 27, 2026. [Online]. Available: <https://patents.google.com/patent/US7270644B2/en>

Conclusions/action items:

Patents are great and all, we just have to make sure to avoid copying the entire design, as that would be an infringement of the patent. Our design contains bits and pieces of all these other ideas, but nothing blatantly copied work for work. We will have to keep detailed documentation throughout the semester if we want a chance at being patented at all.



Title: Materials Research for the Design Matrix

Date: 02/12/2026

Content by: Alex Conover

Present: N/A

Goals: Understand the 3 materials we're planning on testing and using in our design.

Content:

TPU Research Summary

TPU is a rubber-like thermoplastic elastomer with a balance of flexibility, strength, and durability that makes it ideal for flexible parts. It typically has high tensile strength (~75 MPa) and elastic modulus around 4 GPa, with good elastic recovery and flexibility. TPU also offers abrasion resistance, impact resistance, chemical resistance, and decent thermal properties, and it's widely used in wearables, gaskets, shock absorbers, and flexible joints in 3D printing [1].

Elastic Polyester Summary

Materials marketed as elastic polyester usually involve polyester blended with elastic fibers (like elastane/spandex). Elastane itself does not stand alone in most fabrics but provides high stretch and recovery (often stretching 15-45 % or more) when blended. Polyester contributes high strength, durability, and low moisture absorption, while the elastic fibers in the blend give the fabric stretchability and shape retention—important for activewear, fitted clothing, and comfortable textiles [2].

Ballistic Nylon Summary

This research studies how nylon materials behave under deformation in ballistic contexts, meaning how they stretch, compress, or distort when impacted at high speeds or under load. The focus is on nylon fabrics and composites used in ballistic protective systems, examining factors such as:

- Mechanical response under impact or quasi-static loads, Deformation mechanisms (e.g., fiber yielding, yarn pull-out, weave distortion), Comparisons between different nylon material constructions or treatments, Behavior relevant to stopping projectiles or resisting penetration[3].
- Nylon materials in ballistic use must balance stiffness and ductility—too brittle and they fail early, too flexible and they deform without stopping momentum.
- Tests usually quantify yield strength, ultimate strain, energy absorption, and strain modes.
- Results inform designers about what nylon constructions are most effective in protective systems [3].
- Young's modulus 2-4 GPA dependent on the weave strength

References:

[1] "Flexible TPU Filament for 3D Printing:Uses & Applications," Divbyz. Accessed: Feb. 12, 2026. [Online]. Available: <https://www.divbyz.com/knowledge-center/materials/tpu>

[2] "Elastane Fabric: Excellent Elasticity, Perfect Fit." Accessed: Feb. 12, 2026. [Online]. Available: <https://www.grouppf.com/info-detail/elastane-fabric>

[3] M. T. Smith and E. M. Patton, "Evaluation of the Deformation Behavior of Nylon Materials Used in Ballistic Applications," Jun. 1986, Accessed: Feb. 12, 2026. [Online]. Available: <https://apps.dtic.mil/sti/html/tr/ADA171281/>

Conclusions/action items:

This research will be implemented into picking the options for our design matrix, and rating our options (more specifically). This research will be ongoing, and the testing that we will do later in the semester will contribute towards picking our final material for the brace.



03/05/2026 - Patent Research, Dorsiflexion Specific

Alex Conover - Mar 05, 2026, 12:06 PM CST

Title: Patent Research, Dorsiflexion Specific

Date: 03/05/2026

Content by: Alex Conover

Present: N/A

Goals: Learn more about patents that exist for AFOs with dorsiflexion straps.

Content:

1. Flexible Ankle-Foot Orthosis (US20210205109A1) - <https://patents.google.com/patent/US20210205109A1/>

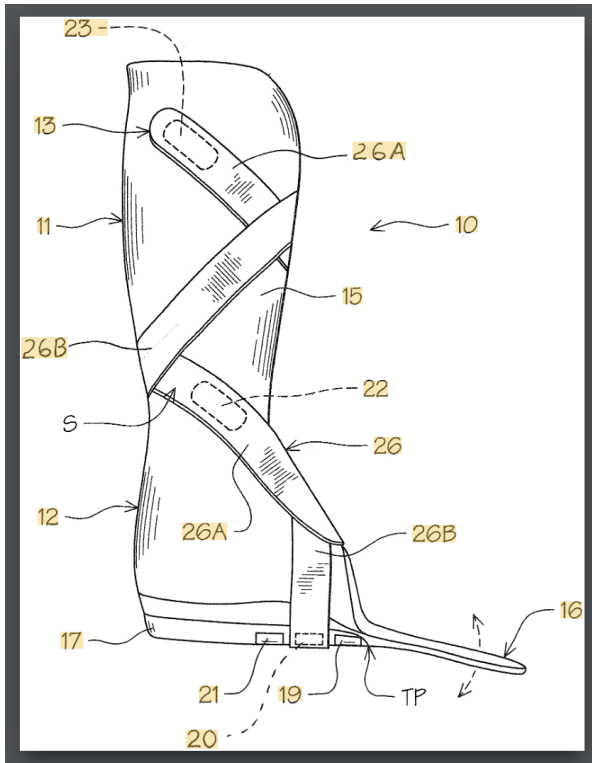

- US20210205109A1 Flexible Ankle-Foot Orthosis patent

Key idea: Adjustable elastic strap that crosses the foot and attaches to the orthosis body to influence dorsiflexion.

Relevant claims/features:

- Orthosis with elastic strap system that can be repositioned across the foot.
- Strap tension can assist dorsiflexion or resist plantarflexion.
- Attachment points allow cross-foot routing of the strap.

Similarities to our Design:

- Uses crossing straps to influence ankle position.
- Strap tension changes foot angle relative to the tibia.
- Foot-surface attachment points distribute load.

Potential differences from our Design:

- Strap is usually across the dorsal foot, not necessarily under the metatarsal heads.

2. Ankle-Foot Orthosis with Tension Strap (US10849778B2) - <https://patents.google.com/patent/US10849778B2/en>

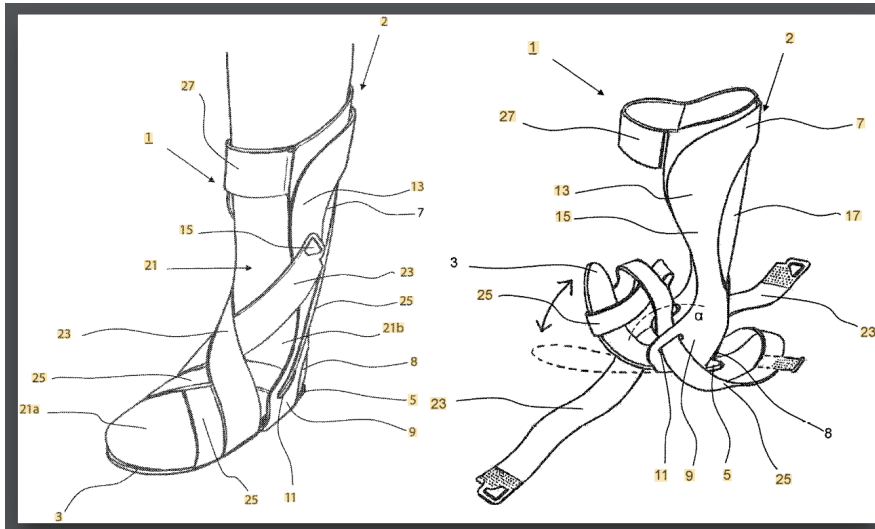

- US10849778B2 Ankle-Foot Orthosis patent

Key idea: Elastic tension strap runs from the lower leg shell over the foot and ankle to provide restoring force.

Relevant design elements

- Strap extends from the leg shell over the instep.
- Produces restoring torque to pull the foot upward.
- Used for foot drop correction.

Relevant Design Specs:

- Generates dorsiflexion assistance via tensioned strap.
- Routing across the foot produces moment about the ankle joint.

Potential differences from our Design:

- Strap typically sits on the instep (top of foot) instead of under the forefoot.

References:

- [1] A. T. M. Voskuilen and A. L. I. Yap, "Ankle-foot orthosis," US10849778B2, Dec. 01, 2020 Accessed: Mar. 05, 2026.
 [Online]. Available: <https://patents.google.com/patent/US10849778B2/en>

[2] J. W. Whiteside, "Flexible ankle foot orthosis," US20210205109A1, Jul. 08, 2021 Accessed: Mar. 05, 2026. [Online]. Available: <https://patents.google.com/patent/US20210205109A1/en>

Conclusions/action items:

These two designs are very similar and do include the options to have an over the foot strap. I see why we didn't receive a patent...



03/05/2026 - Patent Research, Medial/Lateral Specific

Alex Conover - Mar 05, 2026, 12:19 PM CST

Title: Patent Research, Medial/Lateral Specific

Date: 03/05/2026

Content by: Alex Conover

Present: N/A

Goals: Understand more of the patents that exist that would be similar to the medial/lateral aspect of our design.

Content:

1. Carbon-Fiber AFO with Medial and Lateral Struts - US8465445B2

<https://patents.google.com/patent/US8465445B2/en>

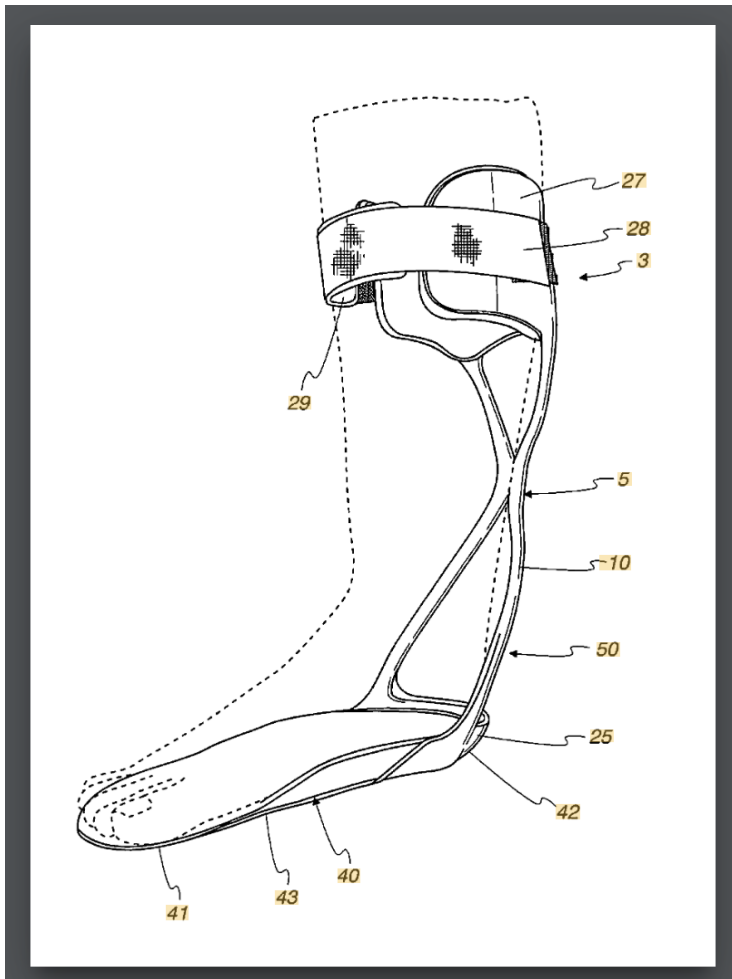

Key concepts

- Carbon-fiber AFO with structural struts that can be medial, lateral, or bilateral.
- Struts connect a footplate to a calf band, storing and releasing energy during gait.

Relevant Claims to our design:

- Orthosis includes one or two vertical struts positioned medially and/or laterally.
- Struts are laminated carbon fiber and function as energy-storing springs.
- Can be fabricated from custom molds of the patient's limb.

Similar to our design:

- Uses carbon fiber structural components located on the medial/lateral sides.
- Custom fabrication based on a plaster mold of the patient's leg/foot.

Differences from our design

- These struts typically run vertically from the footplate to the calf, not plates molded directly along the sides of the foot.

2. Custom Carbon-Fiber AFO with Molded Components - AU2022303313A1

<https://patents.google.com/patent/AU2022303313A1/en>

Key ideas towards our design:

- AFO constructed with a carbon-fiber footplate combined with formable layers that mold around the foot and boot geometry.

Relevancy:

- Uses carbon fiber composite layers shaped around portions of the foot.
- Emphasizes custom molding for fit and structural stiffness.

Differences from our design:

- Most of the structural reinforcement still occurs in footplates or vertical struts, not independent side plates.

References:

[1] P. George, "Ankle and foot orthosis," US8465445B2, Jun. 18, 2013 Accessed: Mar. 05, 2026. [Online]. Available: <https://patents.google.com/patent/US8465445B2/en>

[2] Z. BORNHORST, M. G. DIAZ, P. H. LI, K. MCGEE, E. NAVARRETTE, and A. THOR, "Ankle foot orthoses and method of manufacturing," AU2022303313A1, Jan. 04, 2024 Accessed: Mar. 05, 2026. [Online]. Available: <https://patents.google.com/patent/AU2022303313A1/en>

Conclusions/action items:

Most existing AFO patents use carbon-fiber struts and footplates to assist dorsiflexion, but few place custom-molded carbon-fiber plates along the medial and lateral sides of the foot with a strap running under the ball of the foot, making our design somewhat different from our approach.



02/02/2026 - Fall 2025 Reflection

Alex Conover - Feb 02, 2026, 6:06 PM CST

Title: Fall 2025 Reflection of Content

Date: 02/02/2026

Content by: Alex Conover

Goals: Review and come up with a list of how many pros vs cons there were in the fall semester.

Content:

Overall, I thought the fall semester went really well. As the team leader and returning member of this project, my goal was to teach the BME 200 sophomores how the design process worked (in this application), and try to fast-track our way to prototyping and testing. I personally wanted to have our new prototype finished by show and tell, and then perform testing earlier so we had more time to upgrade/finalize the design, and send to the client for usage. The team was held back by the availability of the client and patient, as they were coming from Michigan to come and test with us, as well as our availability due to my commitments (band), and other team members' events (cross country, birthdays, etc). Overall, we were able to complete a final prototype with ample time remaining in the course, just not as much as I had hoped.

The testing we were able to complete was very thorough, in my opinion, for what we were working with. We performed a gait analysis using force plate testing, as well as a balance test. Despite these results not providing significant data, I believe it was a good experience for all parties involved, especially our BME 200 students. They were able to learn about how to collect that data, how many trials we performed, and other aspects of testing. I shouldered much of the load to interpret the data and analyze the patterns within, and maybe that coding practice could have been spread to the BME 200 students, but many of them did not have adequate MATLAB experience and were preoccupied with other areas of the project at that time.

I also shouldered much of the load for fabrication, mostly the physical preparation and crafting of the brace. Sean (BME 200) did an excellent job crafting the brace in Onshape, and we will continue to build upon that model this semester. If we are planning on moving onto carbon fiber, a concrete design will need to be finalized, and fitted with Maggie, to make sure that it fits before spending hundreds of dollars to create a mold and carbon fiber the design. Despite this challenge, I am confident in our ability to fast-track things this semester, as we are working off of very finalized documents from previous semesters, and can test early, and craft a final project we will be proud of.

Pros of Fall 2025	Cons/Improvement Needed Fall 2025
Created a great final design that the client and patient can currently use.	The brace still slips downwards, so a design change is needed there.
Performed well in presentations and provided A-rate documentation.	Further MTS tensile testing could be performed for better data on the materials.
Attained more crafting and designing skills through Onshape and the Makerspace.	A 3-point bending test could also be performed to compare PLA-CF and CF, if we get that far in the spring 26 semester.
Also gained valuable experience in the data analysis area, with Dr. Wille's help.	

Conclusion/Action Items:

Create a schedule (maybe) to schedule out when testing and training will occur, especially with carbon fiber in the mix.

Continue to update the schedule and ideas after the meeting with Debbie on Tuesday morning.

02/02/2026 - Design Upgrade Ideas

Alex Conover - Feb 02, 2026, 6:29 PM CST

Title: Design Upgrade Ideas

Date: 02/02/2026

Content by: Alex Conover

Present: N/A

Goals: Provide ideas about potential design upgrades

Content:

As seen in the uploaded PDF, brainstormed various ideas to upgrade the current design to prevent slippage, make it easier to wear, and produce significant data.

The main three ideas are as follows:

1. Decrease downwards slippage by extending the printed PLA-CF to the base of the foot, at the heel, preventing slippage without hindering the normal gait.
2. Increase longevity of the brace by laser cutting the straps, preventing fraying and excess wear and tear before usage.
3. To add an increased element of dorsiflexion, change the dorsiflexion strap to also arch over the distal end of the metatarsals (metatarsophalangeal joint), increasing the amount of force applied to the foot, decreasing the amount of foot drop and therefore providing significant data.

Another thing to note: the brace upgrade idea to wrap the printed material would hypothetically work, but maybe only in the case of 3D printing. The material would be too organic (maybe) to work with carbon fiber. More research is required in this area to determine if that part of the design is feasible.

Another thought during sketching was to provide exact blueprints for how to recreate the brace, so we can give it to the client at the end, in case they want to make another brace later down the road, but Maggie may not want to wear our version of the brace as she gets older, and the true AFO should provide the adequate support she needs to walk normally.

Conclusions/action items:

Perform materials (carbon fiber) research and figure out exactly how organic a shape we can create.

Continue to brainstorm with other group mates for design ideas.

Alex Conover - Feb 02, 2026, 6:30 PM CST

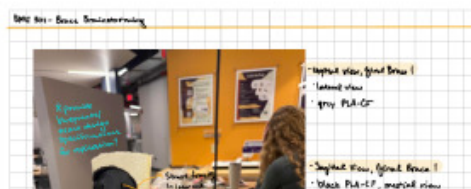

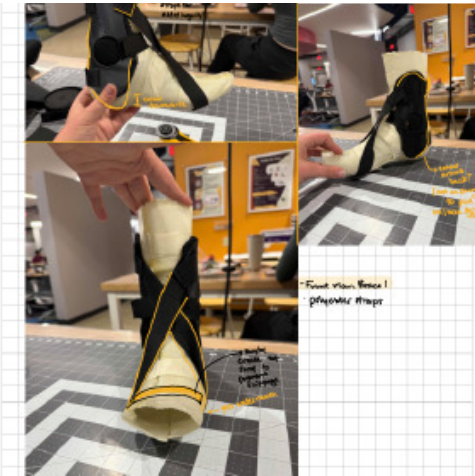

[Download](#)

Design_Ideas.pdf (2.23 MB)



02/03/2026 - PDS rework

Alex Conover - Feb 05, 2026, 5:06 PM CST

Title: PDS rework and reflection

Date: 02/03/2026

Content by: Alex Conover

Present: N/A

Goals: Rework my portions of the PDS and other writing that needs to get done. Also minor reflection on the PDS.

Content:

One of my main goals was to update the problem statement. The general gist of it was the same, but I added a sentence detailing the finale:

Ankle-foot orthoses (AFOs) are designed to support dorsiflexion during the swing phase of walking. They are commonly used in managing muscular dystrophies, and for this project, our focus is specifically on adolescents with Facioscapulohumeral Dystrophy (FSHD), the most prevalent form of muscular dystrophy [1]. Our goal is to create a brace that helps teens achieve safer walking by assisting ankle dorsiflexion, while remaining discreet, lightweight, and flexible enough to allow natural ankle motion. The main design priorities are to position the ankle in proper dorsiflexion, keep the brace slim and unobtrusive, and provide enough flexibility to reduce movement restrictions. This project has been ongoing throughout three semesters, and this semester, spring 2026, will be the final semester of the project; the team is hoping to create a device that fulfills all requests, as well as displays significant data.

I updated various other aspects of the PDS, including performance requirements, aesthetics, patient concerns, additional patient requests, and reviewed the previous patents. The areas that will for sure be updated within the next week include the patient concerns and requests, as we didn't get too much of an update from Ms. Eggleston today. She was unsure if Maggie had been wearing the brace or if she had received it in the mail (we got confirmation she did, so this was a surprise to hear). Hopefully, the team can clear the air and get an update on how much Maggie could feel the braces' influence, both good and bad.

I also redid the calculations in the performance requirements section. This was something I had asked my BME 200 sophomore to take care of, and I missed it on the final (mostly because they didn't update the PDS with any of the feedback from our prior advisor), but who am I to complain? So I finally updated the weight requirement and force applied through the foot. The base normal force is $53.4 \text{ kg} \times 9.81 \text{ m/s}^2$, which is about 524 N of force. Peak forces through the foot are often 3 times that, which is around 1570 N worth of force applied at the step off of each walking step.

The PDS also had some fairly old sources attached to it, and the rest of the team is going through their sections, double-checking sources are still good and applicable, while also fixing any minor formatting issues, updating wording to the present, and making other minor edits to the whole document to make it as streamlined as possible.

Conclusions/action items:

Continue to work on the PDS, and personally, make sure all of the sources are updated (numbered correctly) before being turned in this Thursday.

Also, complete the progress report for the week after working on the remaining entries and PDS content.

Per our meeting with Ms. Eggleston today, we will also start working out the contacts for who we want to speak and work with at the University of Michigan. I will also reach out to our former advisor, Dr. Justin Williams, as he used to work at UM, and may have valuable connections for us.

- **markforged onyx 4 - carbon fibers in the print**
- **can also waterjet the carbon fiber (12 x 12 in in wendt)**



02/10/2026 - Carbon Fiber Manufacturing

Alex Conover - Feb 11, 2026, 12:23 AM CST

Title: Carbon Fiber Manufacturing in Medical Devices

Date: 02/10/2026

Content by: Alex Conover

Present: N/A

Goals: Learn more about the process of manufacturing an external medical device made of carbon fiber.

Content:

Fabrication Methods for Carbon Fiber Components

1. Lay-up and cure method (transitional composite molding)

- wet lay up: CF fabrics are placed in a mold and resin is applied manually, air is removed, part is cured (room temp or heated)
- prepreg lay-up: pre-impregnated fiber sheets (with resin in them already) are placed in molds; then cured under heat/pressure (autoclave...); yields high-quality, high-strength parts.
- vacuum bagging: after lay up, the part is covered with a vacuum bag to remove air and compact layers before cure (common for critical components)
 - These methods are used when surface finish and strength matter

2. Compression Molding

- carbon fiber fabrics or chopped fiber materials plus resin are put into a 2-part mold and compressed under high heat and pressure
- used in high-volume production because the mold can be reused, and the cycle time is shorter than free-handing
- good for repetitive structural parts like standardized external device parts, instrument handles, etc.

3. Sheet Molding Compounds (CF-SMC / Compression Molding)

- CF sheet molding compound (CF-SMC) is a pre-mixed sheet of chopped CF and resin that is placed into molds and compression-cured.
- this allows for automated and fast molding for a high volume
- effective for device bodies or non-continuous fiber structural parts that need mid-range mechanical properties at a moderate cost.

4. Filament Winding

- Continuous carbon fiber tows impregnated in resin are wound around a mandrel in controlled patterns to build pipes, rods, cylindrical things.

- after winding, resin is (heat) cured, and mandrel is removed.
- ideal for tubular structural parts

5. Additive Manufacturing (3D composite printing)

- fusing or depositing carbon fiber reinforced filaments (short or continuous fibers) with a polymer matrix:
 - Fused deposition modeling (FDM) with CF reinforced filament
 - Continuous fiber 2D printing (Markforged, etc): this doesn't require traditional molds and can rapidly produce customizable shapes with controlled fiber orientation.
- useful in medical devices requiring customization (External braces, fixtures, etc)

Heat and Curing

Curing the resin system (thermoset or thermoplastic) is critical to the outcome of the carbon fiber:

- thermoset composites (epoxy, vinyl ester): require heat, sometimes pressure (autoclave/vacuum) to cure into solid structures
- thermoplastic composites (PEEK, nylon): use heat alone to melt and solidify, can be reheated, reformed, and welded
- additive composite printing: often uses local heat to fuse fibers and matrix during deposition.

Medical Device Applications

Typically, CF composites are used for:

- External fixator rods and frames: lightweight, strong, radiolucent
- Surgical instrument handles and components: fatigue resistance and sterilization stability
- Radiolucent instrument tables, braces, and supports (with complex shapes available via AM or molding)

References:

[1] S. Adil and I. Lazoglu, "A review on additive manufacturing of carbon fiber-reinforced polymers: Current methods, materials, mechanical properties, applications and challenges," *Journal of Applied Polymer Science*, vol. 140, no. 7, p. e53476, 2023, doi: [10.1002/app.53476](https://doi.org/10.1002/app.53476).

Conclusions/action items:

Our method of manufacturing is 3D printing, which falls into the additive manufacturing of carbon fiber, albeit it's just the fibers that are reinforcing the medial and lateral sides of the brace.

In order to manufacture with carbon fiber, we would have to get the "composites training" done in the DI shop trainings. In another entry, I will attach the email from fall 2024 detailing where and what capabilities the labs have in order to make carbon fiber stuff.

If we were to utilize CF for our project, it sounds like options 1 or 3 are our best, as 1 give sa good surface finish (which would be necessary) as well as strength, and 3 gives more flexibility with shape, I think. Next steps would be to find out exactly what UW is capable of in terms of designing and manufacturing carbon fiber.

**02/11/2026 - CF Lab Notes**

Alex Conover - Feb 11, 2026, 12:33 AM CST

Title: Carbon Fiber Lab Notes and Fall 2024 Email**Date:** 02/11/2026**Content by:** Alex Conover**Present:** N/A**Goals:** Rehash the points made from the DI lab and makerspace about working with carbon fiber.**Content:****From:** Alex Jean Conover <ajconover@wisc.edu>**Sent:** Tuesday, October 22, 2024 10:51 AM**To:** Maker Contact <maker-contact@engr.wisc.edu>**Subject:** Working with Carbon Fiber in the TEAM-Lab

Hello!

I am Alex Conover, a sophomore in Biomedical engineering. I am currently in BME 200 (mixed with BME 300 and we're working on a project called Ankle Foot Orthosis for Teen, which is us trying to create an inconspicuous ankle brace (ish) for our client and patient. In our final design, we plan to work with carbon fiber to provide the most optimal strength and stiffness for the patient. However, we want to know if we can work with carbon fiber within the TEAM Lab. I know there are some limitations regarding materials and what we can work with, but if you can give us as much information as possible regarding working with carbon fiber in the TEAM Lab, please let me know.

I've attached our final design image for reference and the current SolidWorks model for the carbon fiber piece. We want to make it in 1 piece, supporting the calf and then swooping down to support the medial side of the ankle. Please let me know if you have any questions about our project.

Thank you,
Alex Conover

Hi Alex,
First of all, thank you for sending the drawings! It's very helpful.

We don't allow CF in the main shop, but we do have a post-processing lab for CF inside of the automotive lab. There's a separate [training](#) you'll need to do if you work in there, just because the tools are a bit different and there are some unique hazards with those airborne particles.

It looks like you'll have flat pieces to join, which is good – we aren't set up to do layups. The post-processing lab is for shaping/sanding only.

I've CCed Pete Noonan, our graduate student, who can help answer any questions you have about using the lab!

Best,
Carly

Design Innovation Lab

ECB Shops

(608) 261-1112

making.engr.wisc.edu

College of Engineering | University of Wisconsin-Madison

Conclusions/action items:

The files mentioned in the email are attached here, for reference, to see what the design used to look like, and to know what we were asking for at the time.

From the previous research, the team would have to complete the composites training in order to work with and refine any carbon fiber materials we create. It might be worth it to have the space create the device for us, rather than risk us in the lab. Also our expertise is lacking, and maybe a consult should be considered to determine if the experts think this is feasible with the methods of creation in the last research entry, as well as the information included in this email.

Also from the email, we can see that the lab doesn't do lay-ups, which was method 1 of fabrication in the previous research entry about carbon fiber. We would have to turn to method 3 (molding) or stick with 3D printing. There is another printer that we might use to create a finer product than what we currently have.

Next steps for carbon fiber might mean consulting with the team-lab to see what kind of insight they might have, as well as possibly completing the composites training. Link to the training can be found somewhere in here:

<https://making.engr.wisc.edu/equipment/composites/>

Alex Conover - Feb 11, 2026, 12:28 AM CST

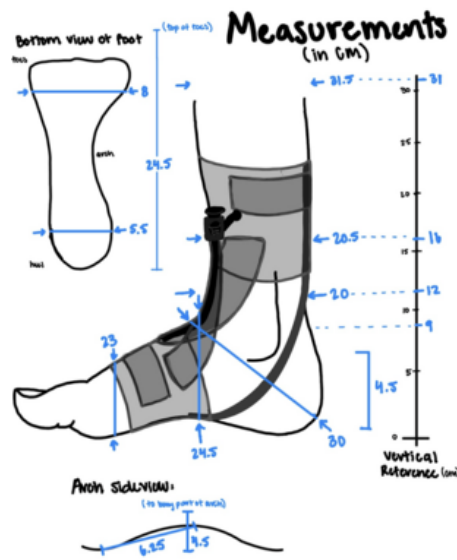

[Download](#)

AFO_Brace_Final.png (650 kB)

Alex Conover - Feb 11, 2026, 12:28 AM CST

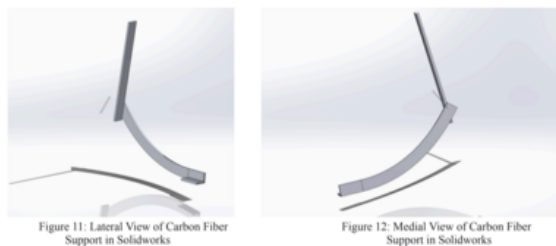

[Download](#)

AFO_Solid_Works.png (174 kB)



03/05/2026 - Design Update Ideas

Alex Conover - Mar 05, 2026, 10:20 AM CST

Title: Design Update Ideas

Date: 03/05/2026

Content by: Alex Conover

Present: N/A

Goals: Document the design update ideas discussed in the team meeting(s).

Content:

The team has had several good ideas for updating the design. Here are some of the following written down:

1. Medial/Lateral Updates

- Even though the client updated us, saying the patient's health had gotten better and might not need the medial/lateral support as much, they are still a very integral part of our design.
- In order to prevent further slippage of the sides downward, the team will lower the sides to the ground.
- The upward force imparted through the brace by having it constantly pushing up from the shoe will eliminate the downward slippage that the device may encounter
- A drawback to this change would be that the device would be larger, and less inconspicuous, but for prioritizing functionality, I think the trade-off is worth it

2. Dorsiflexion strap slippage update

- One of the issues that the patient expressed during our communication about the device was that the dorsiflexion strap that runs under the balls of the foot occasionally slipped towards the heel.

- Several Solutions were proposed:

- Adding grips to the bottom of the front of the strap (hot glue, think grippy sock material, etc).

- Adding grips to the bottom of the strap would prove to be a challenge.
- If the hot glue doesn't adhere to the chosen material, then it's useless.
- The method of adherence for a not a hot glue-based material would add more bulk to the design too.

- Adding a toe sleeve on the end to prevent slippage overall

- Would increase the level arm - provide greater dorsiflexion via torque of the ankle.
- Could be uncomfortable to wear if the material is not breathable.
- Sewing would be the best option to adhere the material to the actual brace, but the material type would need to be researched.

- Lowkey the team could cut the end off of a sock and use that on the brace...

- The team will likely go with the sock toe idea, as it has fewer drawbacks and potential pitfalls than adding grips.

3. Dorsiflexion Material Updates

- Despite the team completing MTS testing and are working on parsing the data, earlier research revealed that the elastic polyester material might still be the best way to go

- The TPU filament might not be flexible enough to provide the user experience requested from the client, and overall performed super close to elastic polyester, leading us to re-evaluate our research and material choices.

- The Elastic Polyester material is breathable, stretchy enough for us to work with, and easy to fabricate.

- The only drawback we experienced with it was the insignificant data from last semester, which wasn't even with the final brace. The lack of significance was likely due to the dorsiflexion strap not including enough upward pull to support the gait analysis

- A solution to not having enough dorsiflexion support would be to shorten the strap on the brace, leading to less material, but overall allowing the strap to be tighter on the foot, bringing the (hopefully) adequate level of dorsiflexion up to match what the foot needs to walk normally.

4. Testing Updates

- The team is starting the drafting of the testing plans we will send to UMich. The testing that we want done will be determined by how many braces we create.

- The current roster of braces includes the brace sent to the client and a replica in the hands of the team.

- With the proposed design changes, the team could make one more replica of the Fall 2025 brace, with a TPU strap, while shortening the dorsiflexion elastic polyester strap on the team's replica for ease of comparison.

- If the TPU proves to be a worse option in the parsed data, then the final manufactured brace will simply extend the medial/lateral sides downward and have a shorter dorsiflexion strap.

- Once the number of braces has been decided, the testing plans can be fully detailed.

Conclusions/action items:

Continue to communicate with UMich friends and professors to work out a testing date.

Create the Testing Plans document and detail exactly what we want to see done with our devices.



03/10/2026 - Fabrication 1

Alex Conover - Mar 12, 2026, 12:42 PM CDT

Title: First round of Fabrication

Date: 03/10/2026

Content by: Alex Conover

Present: Whole team

Goals: Start (and hopefully finish) the fabrication of the AFO.

Content:

Spoiler alert, the team did not finish the fabrication of the brace.

To start, the team measured the straps that already existed, because someone wasn't smart enough to write down distances last time they fabricated, don't know who that was.

- For context, the prior braces were fabricated using the model of the foot that the team has, because it's an accurate enough model to create a good sized brace, and exact dimensions were never recorded.

The following dimensions were checked:

- Back Straps of the brace: 6 inches each total length, non-adjustable on the brace.
 - Strap length can be adjusted manually by cutting the straps for a closer fit to the model.
- Dorsiflexion strap: total of 18 inches on the working end, with approximately 2 more inches in the brace holding it onto the brace, for a total of 20 inches
 - The team wants to adjust the level of dorsiflexion, so the strap will be shortened by 2 inches, for a total of 18 inches
 - the strap is also sewn all the way down to reduce the stretchiness of the brace; this will also be completed if the team doesn't fight with the sewing machines again.

Fabrication of the Medial/Lateral Pieces:

The team started with the medial and lateral pieces, cutting the mesh fabric to fit around the outsides of the brace to prevent unnecessary abrasions.

- This process is not exact. The dimensions of the medial and lateral pieces will be detailed in the fabrication notes of Kalob's entries.

The medial/lateral pieces are placed onto the mesh, a white fabric pencil is used to get a rough outline of the parts, then fabric scissors are used to cut out 2 copies.

The 2 copies are then sewn together, ideally with a sewing machine, but we had to hand-sew the part this semester due to the machine fighting back.

- A total of 4 swaths of fabric are cut from the mesh, 2 of each side, then those of each respective sewn together, the side without the porous fabric faces outwards, while the smooth side faces inward for easy adherence to the PLA-CF

print.

Once both sides are sewn, they can be superglued to their respective sides. A generous amount of superglue is applied to the print, and the fabric is glued to the brace.

Fabrication of the Straps:

The back and front straps are relatively simple.

- Cut the ballistic nylon with a fabric scissors, or ideally a fabric roller cutter (for straighter lines) into 1-inch wide by 6 inches in length pieces (x2), then cut a piece that is 1 in wide by 12 inches long.

Once cut, all pieces are attached to the brace in their respective places.

- back straps are unadjustable, and completely sewn together to eliminate any slippage.
- the front strap is only secured on one side, as the other side utilizes velcro to be an adjustable strap.
 - A 1 inch by 2 inch piece of velcro is cut and adhered with the adhesive already on the velcro

The dorsiflexion strap was measured to be 20 inches, we changed it to 18 inches, then doubled the strap up on itself and cut.

- the folded piece is then sewed together completely to avoid any slippage of the brace, and help reduce the stretchiness
- It is then attached via sewing to the brace and held in place to avoid slippage.

Alex completed the sewing with Avery, and then Alex glued all the stuff together. Kalob and Avery worked to sew the back straps, with Kalob fighting the sewing machine with the ballistic nylon. Sierra helped cut out the fabric before she had to go to 315 lecture.

The front strap was also sewn by Avery and Kalob, Alex helped with the velcro.

Then someone (Alex) accidentally made the strap half as long as it was supposed to be, and we ran out of time before the 430 lecture. The fabrication will have to continue another day!

Conclusions/action items:

Finish the overall fabrication of the brace this week so that we can work on shipping it out next week.

We ultimately won't have a prototype for show and tell, because it will be on a truck to Michigan, but we will have adequate pictures and descriptions.



03/12/2026 - Fabrication 2

Alex Conover - Mar 12, 2026, 1:05 PM CDT

Title: Finish the Fabrication of the brace

Date: 03/12/2026

Content by: Alex

Present: Alex and Sierra

Goals: Actually finish the whole fabrication of the brace.

Content:

Surprise! We did finish it this time! (For the most part).

Sierra and I worked to complete the brace in the morning of 3/12; the only parts left to complete were the dorsiflexion strap, and maybe the sock part.

The dorsiflexion strap was cut to the right length this time, of 18 inches, then sewn together and sewn to the brace.

The velcro was peeling a little bit on the front strap, so I added some superglue around the edges to hold it down a little more securely. Sierra worked to sew the 2 halves of the brace together, and then I sewed it to the brace itself.

Once all of the pieces were put together, we assessed the other pieces to make sure everything was still steady from fabrication 2 days prior. Everything was, which was a good sign.

Problems we ran into for fabrication:

- The general sewing machines that the makerspace has are not heavy-duty enough to work with mesh fabric, ballistic nylon, or elastic polyester.
- Sewing by hand takes a long time.
- Not knowing various dimensions (fixed with measurements...)

Overall, the process went well, and we ultimately have another brace with updated features. Kalob might add the sock idea to the brace, but TBD depending on how much time we have.

Conclusions/action items:

We will continue to refine the brace and add any other modifications we deem necessary.

We plan to ship the brace next week!

Alex Conover - Mar 12, 2026, 2:01 PM CDT





[Download](#)

IMG_5532.jpeg (3.84 MB)

01/27/2026 - Lab Training

Alex Conover - Jan 28, 2026, 1:11 PM CST

Title: Lab Training

Date: 01/27/2025

Content by: Alex Conover

Present: N/A

Goals: Upload the certifications I've obtained.

Content:

See attached document for proof of HIPAA training, lab training, both chemical and physical, and whatever other trainings I had done for this documentation.

Conclusions/action items:

Ta da!

Alex Conover - Jan 27, 2026, 10:36 PM CST



Course	Assigned on	Completed on	Expired on
2025-0001 HIPAA Privacy & Security Training	2025-0001 HIPAA Privacy & Security Training	01/27/25	
2025-0001 HIPAA Privacy & Security Training	2025-0001 HIPAA Privacy & Security Training	01/27/25	
OSHA 10-Hour Construction Safety Course	OSHA 10-Hour Construction Safety Course	01/27/25	01/27/26
Chemical Safety Training (MSHA 10-Hour)	Chemical Safety Training (MSHA 10-Hour)	01/27/25	01/27/26
OSHA 30-Hour Construction Safety Course	OSHA 30-Hour Construction Safety Course	01/27/25	01/27/26

<https://my.eplanning.mhs.wisconsin.gov/TLT/Data.do?BID=1832>

[Download](#)

training_documentation.pdf (154 kB)



02/05/2026 - Woodshop Training

Alex Conover - Feb 05, 2026, 5:09 PM CST

Title: Woodshop Training

Date: 02/05/2026

Content by: Alex Conover







Present: N/A

Goals: Complete the required training for BME 301, by choice. Finally complete the woodworking training that I've been pushing off.

Content:

I spent 20 minutes working through the training and overview of the woodworking training. I'm fairly well-versed in the different wood shop tools already, as I've had enough experience working with my father on projects throughout my life, but training for safety is necessary.

I will continue to work through this training, as well as others, especially since it's required for the class.

▼ Woodworking		Prerequisites: Intro to Shop Tools (Pre-Lab)	Complete All Items	✓
	Woodworking: Welcome! 2 pts Scored at least 2.0			✓
	Woodworking: Our Shops 3 pts Scored at least 3.0			✓
	Woodworking: Wood 101 5 pts Scored at least 5.0			✓
	Woodworking: Safety 3 pts Scored at least 3.0			✓
	Woodworking: Equipment Overview 5 pts Scored at least 5.0			✓
	Woodworking: Next Steps 3 pts Scored at least 3.0			✓
	Woodworking: Orientation Signup			
	Woodworking: Resources			

In-person training is on Monday, February 9th, from 6:00-6:30pm.

Conclusions/action items:

Continue to research the carbon fiber opportunities we can work with.

Finish entries for the next week.

03/29/2026 - Woodshop Certification

Alex Conover - Mar 29, 2026, 9:26 PM CDT

Title: Training in the Curriculum - Wood shop Training Completion

Date: 03/29/2026

Content by: Alex Conover

Present: N/A

Goals: Upload the completed woodshop training certification.

Content:



**ALEXANDRA
CONOVER**

ID Number: 908526336
7

Eligibility: CoE
Students

- Profile
- Program Registrations
- Bookings
- Memberships
- Orders
- Invoices

My Memberships				
Membership Type	Start Date	Expiry Date	Renew	Card Info
Woodshop Orientation	Mon, Feb 9 2026	Permanent	Not Renewable	N/A
Woodshop Orientation Eligible	Wed, Aug 20 2025	Wed, Dec 31 3000	Not Renewable	N/A
Machining	Tue, Aug 20 2024	Permanent	Not Renewable	N/A
Laser Cutter	Tue, Aug 20 2024	Thu, Jan 2 3000	Not Renewable	N/A
Laser Cutter	Wed, May 17 2023	Wed, Jan 1 3000	Not Renewable	N/A
Shop Tools	Thu, May 11 2023	Wed, Jan 1 3000	Not Renewable	N/A
Access Fee	Sun, Jan 22 2023	Sun, May 19 2024	Not Renewable	N/A
Lab Orientation	Sun, Jan 1 2023	Tue, Dec 30 3000	Not Renewable	N/A
Shop Tools - Training Eligible	Sun, Jan 1 2023	Tue, Dec 30 3000	Not Renewable	N/A
Laser Cutter - Training Eligible	Sun, Jan 1 2023	Tue, Dec 30 3000	Not Renewable	N/A

Conclusions/action items:

For the training in the curriculum!



01/28/2026 - Library Session 1

Alex Conover - Jan 28, 2026, 1:51 PM CST

Title: Library Literature Search

Date: 01/28/2025

Content by: Alex Conover

Present: Avery, Sierra, Kalob

Goals: Learn more about article searching, source evaluation, and citation management.

Content:

AI Technology vs Chatbots vs Online Search Engines

Main difference - chatbots are trained on internet data (can produce internet data, or false data), whereas databases and pulling their info from a set piece of information.

AI Chatbots

- are predictive text generators, not search engines (although some now integrate search engines)
- do not evaluate for accuracy, bias, or credibility
- generate factually incorrect statements
- make up sources
- doesn't answer prompts consistently
- are trained on undisclosed data that:
 - retain systemic biases, may not be current, etc

Evaluating your sources

Relevance: what is this source about?

Authority: who created this?

Quality: why was this written and how does that affect the information?

Currency: when was this source created?

- read laterally!

Technical Reports

Technical reports publish the results of scientific or technical research, often using federal funds. The research is performed and reports are produced by companies, universities and government laboratories.

Find information on technical reports in the Libraries; recommended data bases include:

- DTIC (Department of Defense), NTRL (Department of Commerce and more), OSTI (Department of Energy)

Citation Manager - Zotero

I use zotero, so this is review.

- I love citation generation for free

Zotero has been upgraded a few times since I downloaded it last - I redownloaded the app and reconnected to ensure accurate/best citations and the most up-to-date version of the app.

Kuhlthau's Information Search Process

Exploration, when inconsistent, incompatible information is encountered and uncertainty, confusion, and doubt frequently increase and people find themselves "in the dip" of confidence.

- Eventually, you will find what you were looking for, despite the massive influx of resources you may have to sort through, but with perseverance, you will find what you are looking for eventually.

Conclusions/action items:

Continue to use zotero as a citation manager throughout the PDS/Reports, it cuts down on time and effort needed to manage citations, especially with the sheer amount that we use in BME.

Use the library resources to find good, credible, relevant sources. ChatGPT can only go so far.



02/04/2026 - Lecture 2 (JOBS)

Alex Conover - Feb 05, 2026, 11:55 AM CST

Title: Industry, Resume Review, Etc

Date: 02/04/2026

Content by: Alex Conover

Present: Avery, Sierra, Kalob

Goals: Learn more about resume review and see what the general BME population wants to learn about

Content:

Resume Review!

Summer Research applications are due this week and next week.

Trying to find an application that fits best what I want to do...

Uploaded copies of the in-class activity with new peers.

- I really need to update my resume...

Conclusions/action items:

Final Resume and application is due Feb 10th next week (Tuesday). Update it with the knowledge from class as well as any other professional advice.

Alex Conover - Feb 04, 2026, 1:49 PM CST

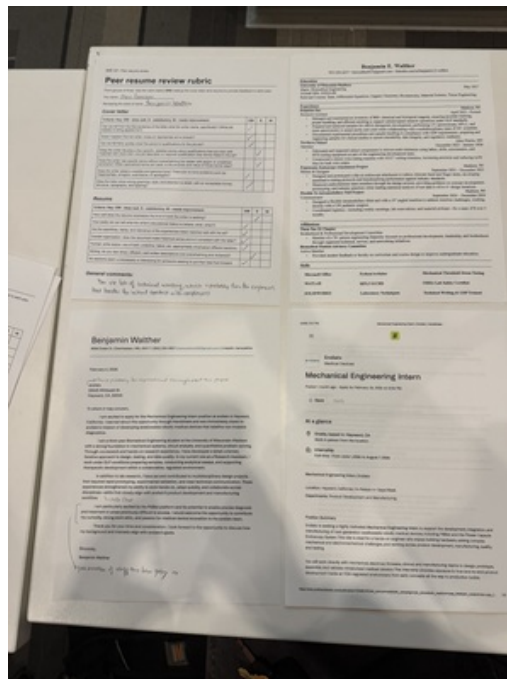

[Download](#)

IMG_4908.jpeg (4.94 MB)

Alex Conover - Feb 04, 2026, 1:49 PM CST

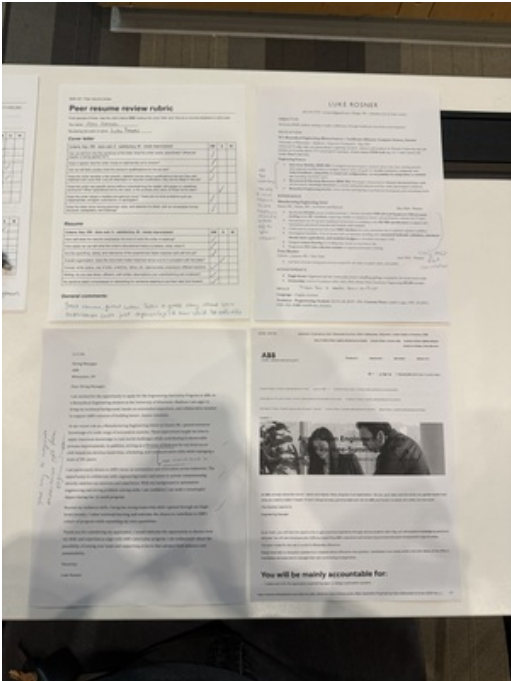

[Download](#)

IMG_4909.jpeg (5.19 MB)



02/11/2026 - Lecture 3 (interview)

Alex Conover - Feb 11, 2026, 1:39 PM CST

Title: Presentation Review, Interviewing

Date: 02/11/2026

Content by: Alex Conover

Present: Avery, Sierra, Kalob

Goals: Notes about the preliminary presentation, interviews

Content:

6 x 6 rule (6 bullets and sentences, etc)

Design matrix in order. Design matrix correctly highlighted.

Check font consistency

Don't use hanging bullets (beyond 2...)

- Dr. P hates hanging bullets. just combine them.

Figure captions: highlight key features...

CAD design, use the screenshot, not a professional drawing...

- make sure to also measure dimensions on the CAD drawing, well labeled with what the things are.

- professional drawing is for machining...

- handwritten drawings are not preferred (specifically labels) - a nice sketch done (on an ipad or whatever) is fine

Graph! no raw data!

- statistics:

- 3 trials; bin trials - average +/- standard deviation

Use effective storytelling with figures (how does the design work?) - exploded view

Interviewing Guidelines

- Reference specific policies, products, ideals, etc

- bring a portfolio

- ask questions post interview

Conclusions/action items:

The document with the job interview responses will be attached at the end here.

Preliminary presentation will be created and started this weekend.

Alex Conover - Feb 11, 2026, 2:16 PM CST

BME 301: Job Interviewing

Interview questions

While engineering interviews will often ask you a number of technical questions to ensure you have the skills that they need, they will often choose a set of behavioral questions to determine what kind of employee you might be and how you handle non-technical situations. Familiarize yourself with these sorts of questions so that you are not surprised by them in an interview.

1. Talk about a weakness or challenge you've had to overcome in your life.
2. Consider your most recent engineering job or academic engineering project. Tell us one thing that you've learned recently from that job or experience.
 - a. Something that I've learned from BME 301 but remember is that a fresh set of eyes is never a bad experience, especially on a project that has been ongoing. Sometimes you need a new perspective. In the project to build a robot across new ideas that I ultimately used in a working prototype. Even those with less experience (BME 200) had useful insight into the project, and provided useful skills and information despite their lack of design experience. They were a member to seek, and can contribute to the project one way or another.
3. Talk about a serious mistake or a time when you failed at something pretty important, and explain how you resolved it or dealt with it.
4. Talk about a time in your life when you had to move to live in a different area; what were the big challenges about the move, what made your most uncomfortable, and what strategies did you develop to become more comfortable? How did you deal with the change?
5. Sometimes it is necessary to give other people bad news or criticism in order to achieve a positive goal or to avoid a potentially more serious problem. Describe a time when you communicated something unpleasant or difficult to say to your manager, your professor, or your peers.
6. Tell me about a specific experience of yours that illustrates your ability to influence another person verbally. Feel free to use an example that involves changing an attitude, selling a group on an idea, or being persuasive about a goal that you had.
 - a. In my work experience at Keysight Technology, I worked with some other students in the marketing department. The goal was to create 4D cases in three months, by hand, to create a newer, updated library of courses for Keysight. Before my co-intern arrived, I was faced to create a streamlined process to create these new courses, on a scale of 100, with AI and product manager input. Once she arrived, I worked to convince her to use the method to create these courses, as well as creating SOPs (processes) to create these courses for new workers, who no one could offer me. We were successful in a reform, working across Keysight, with multiple product managers, and modules to create over 50 new courses, for over 100 total assets in the new education system.
7. It's sometimes important to deal with someone who has a negative attitude – especially when you need to work together to accomplish a task. Give me an example of a time when you confronted a negative attitude.
8. When you're not at work, what do you do that is two standard deviations better than anybody else?

Adapted with permission from InterGQR 2027

1

[Download](#)

Alex_Conover_-_BME_301_-_Job_interview_activity.pdf (92.8 kB)



02/18/2026 - Lecture 4 (Feedback)

Alex Conover - Feb 18, 2026, 4:27 PM CST

Title: Presentation Feedback Lecture

Date: 02/18/2026

Content by: Alex Conover

Present: All Team

Goals: Receive feedback on the preliminary design presentation in the lecture.

Content:

Some of the most common feedback was to cut down on the number of words that we used.

We will also edit some of the slides to look a bit better, cutting down the hanging bullets.

We also as a team left comments on the group ahead of ours, my feedback is attached below here.

Conclusions/action items:

Finish the presentation with the feedback we were provided.

Meet at 7 pm Thursday to practice the presentation out loud.

Actually give the presentation this week Friday at 1:35pm.



02/25/2026 - Lecture 5 - Diversity and Inclusion

Alex Conover - Feb 27, 2026, 11:40 AM CST

Title: DEI lecture in engineering

Date: 02/25/2026

Content by: Alex Conover

Present: Avery, Kalob, Sierra

Goals: Brainstorm and understand diversity equity and inclusion within the engineering spectrum.

Content:

Team Brainstorming

- Diversity List

- creating affordable designs for all people to access
- creating designs that cater to all people
- taking into account all sorts of backgrounds (financial, cultural background, upbringing, etc)
- catering to all people
 - using ergonomics to cater to all body types (think percentiles)
- research all sides of a topic/idea
- wide accessibility of design

Universal Design

- creating multiple designs if a "one-size-fits-all" idea doesn't actually fit all.
- taking into account all factors, such as age, disability, capability, etc.

7 Principles of Universal Design

1. Equitable Use

- useful and marketable to people with diverse abilities
- safety, privacy appealing to all users

2. Flexibility in Use

- accommodates a wide range of individual preferences and abilities
- provide choice in methods of use

3. Simple and Intuitive Use

- understand regardless of experiences, knowledge, language skills, or current concentration level.

- eliminate unnecessary complexity

4. Perceptible information

- design communicates necessary info effectively to the user

5. Tolerance for Error

- minimizes hazards and the adverse consequences of accidental or unintended action

6. Low physical effort

- can be used efficiently and comfortably, and with a minimum of fatigue

7. size and space for approach and use

- appropriate size and space is provided for approach, reach, manipulation, and use regardless of the user's body size, posture, or mobility

How does this relate to Ethics?

- we want to maximize comfort for more people, design for more people in general

- work for all people

- create safer environments

- design with all peoples in mind

BME Code of Ethics - Assignment

- What components of your design can be improved?

- Different colors (doesn't have to be black/gray)

- different sizes (for overall scope of the project...)

- easier to use

- Which of the 7 principles are you addressing?

3. simple and intuitive use - how to make our product easier to use? (instruction manual)

5. Tolerance for Error - how can we eliminate sharp edges if our product breaks?

6. Low Physical Effort - how can we make the ergonomics of this design better

- How can you make these improvements?

- Create an instruction manual for our design with clarifying images and descriptions, it would make it easier to use and understand.

- Make it easier to determine medial and lateral sides...

Conclusions/action items:

The team should set aside time to work on the universal design principles, as it could really improve the quality of our prototype. Despite not getting a patent, we could still implement a way to make our design more universally wearable, and not just customized to our patient.



03/04/2026 - Lecture 6 - Library Lecture 2

Alex Conover - Mar 05, 2026, 9:50 AM CST

Title: Library Lecture 2

Date: 03/04/2026

Content by: Alex Conover

Present: N/A

Goals: Review the Library Lecture notes post-lecture because I was in Indianapolis.

Content:

Patents, Standards, and Other Design Resources

Mapping the Design process to literature:

- standards
- market/industry databases
- patents

Standards

Our libraries have (Full texts via databases):

- ASTM (American Society of Testing Materials) - includes all ASTM standards, many ISO and IEC standards
- ASABE (Agricultural and Biological Engineers)
- IEEE (Electrical and Computer Engineers)

Historical Print collection at UW

- freely available online: ASSIST Quick search, everyspec, FDA, International Telecommunications Union, nasa, nfpa, etc
- check TechStreet Enterprise for titles and use the request a standard form

Market and Industry Sources

Specific Recommendations:

- Data Axle Reference Solutions: directory information on businesses and demographic and lifestyle information on consumers
- IBIS World Industry Reports - market research reports on over 700 US Industries
- ProQuest One Business: Full text business journals, newspapers dissertations and industry reports.

Patents and Prior Art - Searching

Patent examiners evaluate applications against prior art, which includes:

- inventions disclosed in UW and foreign patents and patent applications
- inventions disclosed in publications
- inventions currently for sale or in public use

Searching for Patents/Prior Art

Squngee - patent number US 64744260

- couldn't find on lens.org, or google patents
 - other things to be taken into account would be other bouncing squirrel feeder ideas, which came up multiple times when searching "Squirrel Feeder" on [lens.org](https://www.google.com/patents/lens)
 - however, the bouncing squirrel feeder did not reveal any patents when searched
 - Overall, one could probably create something novelly different and get a patent.

Evaluation

Patent examiners evaluate for:

- usefulness
- novelty
- non-obviousness

Claims:

- define legally enforceable aspects of patent
- every utility patent has at least one claim
- each claim is a single sentence:
 - Preamble ("An animal feeding apparatus having a first end and a second end")
 - Transition ("Comprising")
 - Antecedent Basis ("a mounting region")

Independent Claims

- Standalone
- Contain all limitations necessary to define an invention

Dependent Claims

- Must refer to a previous claim
- must further limit the claim

- Includes all limitations of the claim it refers to

Evaluation Example:

1. Differences in functionality:

- Squngee:

- Spring/elastic recoil system
- With animal grabbing bait - device drops downwards (spring rapidly recoils upward)
- Scares squirrel away
- Bait is suspended from a vertical rod with mechanical components
- **Purpose:** startle animals to release the ball and provide protection to bird feeder

- Squirrel Bungee Apparatus:

- uses a flexible elastic cord - no strong recoil
- animal hangs and bounces downward
- more like a bungee for squirrels...
- holds corn cobs / bait at the bottom
- **Purpose:** provide a controlled bouncing motion, to entertain people while distracting squirrels from bird feeders

2. Differences in Language Used

Squngee:

- "Recoiling Mechanism", "Spring-based member", "rapid upward movement", "startling the animal."
- claims focus on: mechanical recoil, forceful motion, and deterrence of the squirrel.

Squirrel Bungee

- "Elastic Member", "flexible suspension", "vertical movement", "amusement device"
- Claims emphasize: Elastic suspension rather than recoil, controlled motion rather than startling
 - helps avoid claiming the earlier mechanism

3. Workaround Earlier Patent?

The key mechanism is changed:

- Spring-loaded recoil vs elastic cord suspension
- Rapid snap upward vs smooth bouncing
- deterrent mechanism vs amusement/feeding device
- mechanical assembly vs simple hanging apparatus

Strategies used:

- different mechanical principle (recoil vs stretch)
- different intended function (scaring vs entertaining)
- Different claim language (avoids recoil and spring-biased action)
 - allows for novelty and non-obviousness

4. Market a device without novel features?

Yes, but only yes if:

- The earlier patent was expired (20 years from filing)
- the product does not infringe active claims of newer patents
- you change aspects like: design, materials, mounting, accessories, etc

However:

- cannot patent if it lacks novelty
- cannot copy patented claims if the patent is still active

You could still complete: branding, price, manufacturing improvements, design aesthetics

Patents Relevant to our Project:

See the individual research section of the notebook for specific patents.

Conclusions/action items:

Overall, lens.org and Google Patents are useful resources for comparing patents. We submitted for a patent last semester and did not get it; using the knowledge attained now, we could work on pitching our patent better, and using specific language to describe how our device differs from existing technologies.

Alex Conover - Mar 11, 2026, 10:09 AM CDT

Title: Library Lecture 2

Date: 03/04/2026

Content by: Alex Conover

Present: N/A

Goals: Find a patent that is suitable/relevant for our project.

Content:

Conclusions/action items:



03/06/2026 - Tong Lecture

Alex Conover - Mar 11, 2026, 10:08 AM CDT

Title: Tong Lecture

Date: 03/06/2026

Content by: Alex Conover

Present: Team

Goals: Reflect on the Tong Lecture.

Content:

Dr. Williams was my advisor last semester for the AFO project, and he never really mentioned the other stuff that he was doing beyond advising and teaching. That guy has done so much throughout his career, it's insane. I can't imagine starting 5 different companies in like 20 years, he's insane.

Overall, I thought the talk was super interesting and informative; Dr. Williams is clearly well-experienced and contains a wealth of knowledge, one I was a fool not to access with my time with him. Less is more, and work with good people.

Also he's from Trent, SD, which is crazy work. 91 people? Wow.

This was a great opportunity to learn about his history and how his stuff has worked out.

Conclusions/action items:

Go big or go home lowkey after you have all your stuff figured out through schooling. If you're not content with the job that you have, take advantage of your opportunities presented to have a greater impact on the world.



03/11/2026 - Lecture 7 - Protocol Development

Alex Conover - Mar 11, 2026, 1:56 PM CDT

Title: Protocol Development

Date: 03/11/2026

Content by: Alex

Present: The whole team is present.

Goals: Learn about how to write a protocol.

Content:

Fail Fast and fail forward

- Perfection is not important
 - low fidelity - cardboard, etc
 - start early!
 - test individual pieces
- Documentation still required!
- check out 1080 closet or makerspace 170 leftovers

Preliminary Testing and Analysis

- circuit diagrams and circuit testing
- fittings (connection points)
- simple calculations
- free body diagrams
- mechanics of materials

Planning general concepts for fab and testing

- materials (detailed list) - match material expense table and more
 - Name of material
 - Concentration, amount or starting dimensions
 - Manufacturer and part number
 - purpose of material
 - list of equipment needed (manufacturer and model number if known)

- include references to papers or research in other parts of the notebook
- Methods (step-by-step plan) - list
 - Mix; for how long and with what vigor, etc
 - Cut; with what tool and what size, etc
- Rule #1 - repeatable by an unfamiliar reader

Use your resources!

Jessie Darly - Onshape (we've worked with this guy before in AFO)

Faculty are great resources as well.

Fabrication Plans:

- name of fabrication step/portion of prototype:
- date to be completed:
- team member(s) fabricating:
- detailed sketch of the portion being fabricated
- detailed bullet-pointed steps of fabrication

Testing Components

- Statistics? Sample size? - minimum 3, 6 is good
- What controls are needed?
- Do you have to design something to ensure precision and accuracy
 - Test fixture for MTS
 - apparatus to hold items in a fixed position for motion capture, etc
 - code to perform analysis
- Reference and discuss the PDS criterion being tested
- Testing plan should match fabrication plan (timeline) (each component should be tested individually)
 - **For our example**, we've individually tested materials for both medial/lateral and the dorsiflexion straps.

Conclusions/action items:

We should work out a vigorous fabrication plan and update our testing plans to be more informative of the exact steps we want the people to take, especially since we're not running our own testing.

We are testing the critical criteria of dorsiflexion and medial/lateral support.



03/18/2026 - Lecture 8

Alex Conover - Mar 25, 2026, 1:26 PM CDT

Title: Lecture 8 - Call to Action

Date: 03/25/2026

Content by: Alex Conover

Present: N/A

Goals: Help with the call to action for show and tell.

Content:

I was in Portland, OR, for this lecture. I hate our men's basketball team. Why can't they be as good as the women's hockey team?

Anyways, we got good feedback from show and tell, and the seniors liked our project. I'm excited for the conclusion of our project.

Conclusions/action items:

Continue to work on testing plans, draft the executive summary, and start the final report summary.



03/25/2026 - Lecture 9

Alex Conover - Mar 25, 2026, 2:20 PM CDT

Title: Lecture 9 - Engineering Ethics

Date: 03/25/2026

Content by: Alex Conover

Present: Avery, Sierra, Kalob

Goals: Have a lengthy conversation about ethics in our 301 lecture.

Content:

Personal vs Professional Ethics

- Personal ethics might differ from professional in the sense that personal ethics could be different, or less focused as a professional ethics code may be.

Where do ethics come from?

- personal experiences
- how you were raised
- religion

Ethical Problem solving is similar to the design process

Ethical Decision-Making Process:

Awareness: understand when you're facing a problem with ethical dimensions

Stakeholders

options

analysis of options

- harm test, publicity test, reversibility test, universality test,

Consider the different perspectives on this case listed below, and discuss these questions in detail. Type your responses as a team. Identify one team member to report out to the class.

1. **The Guidant VPs:** Most of the VP's at Guidant are very much against reporting the data to the FDA. (a) How might they continue to justify their case? (b) What would be the moral foundations of their perspective?

a) It's going to affect the marketability of future devices made by Guidant, and it still helps people (despite the rate of complications). They may also have been worried about the cost and losing out on potential profit/bonus within the company.

b) Morally, they are still helping out the patients who are sick.

2. **Patients and doctors:** Think about the position of those directly impacted: primarily patients who might be candidates for this surgery, and the doctors who use the device: (a) what arguments would those people want to ensure are considered by both the

VPs and the design engineers about whether to report or not report the complications data? (b) What might be the ethical foundations of their perspective?

a) The device is still helping people and preventing deaths. All parties involved are doing more procedures, making more devices, and making a greater profit. Not reporting the data would allow the device to continue being used. Patients should be made aware of the true complications of the device. Surgeons

b) The people are still being helped, without the device they would not be able to continue living. Not reporting to the FDA would allow the people to continue to be helped, regardless of if they end up killing another person or not.

3. **The design engineers:** (a) What else can they say or do? (b) What arguments can they try to make, and to whom?

a) The design engineers could have directly reported the findings to the FDA instead of going to the board of directors for the company; this would have placed their jobs in jeopardy if the company found out who told the FDA, but that would also be an illegal firing.

b) They report directly to the FDA and might avoid the loophole of the VP's.

4. **The design engineers:** What options do they have? Generate a list of possible options (a minimum of 3 from the perspective of the design engineers), describe how each stakeholder is affected, then analyze them using the BME Code of Ethics (<https://www.bmes.org/2025/cmbeconference/codeofconduct>) and a couple of tests from the [ethical decision-making system](#). Explain in detail the best option you would consider trying to act on.

Changing the design - not screw up the arteries/veins of the patient. Stakeholders might back out if the information about the misreported cases gets to them; but telling them might be the most optimal thing just to be straight up. Tell the FDA straight, instead of talking to the higher-level VPs; they won't be happy, but it will improve patient and device safety.

Ethics to our Design Project:

Components of our design to face ethical dilemmas:

- We are working with a minor! - Obey HIPAA, informed consent, and keep parents in the loop.

Conclusions/action items:

Thermoforming - Dr. P



04/08/2026 - Lecture 10

Alex Conover - Apr 08, 2026, 2:07 PM CDT

Title: Lecture 10

Date: 04/08/2026

Content by: Alex Conover

Present: Team!

Goals:

Content:

Engineering judgement!

- process of making informed decisions, often in situations where there isn't a clear-cut answer or a specific code, etc

- decisions, problem solving, ethics, evaluation

Good assumptions are part of engineering judgment.

- real-world engineering problems
- open-ended problems
- teamwork and collaboration with others
- critical thinking - evaluate solutions, testing/analysis
- communication
- handling uncertainty
- intuition, etc

Attitudes, behaviors, and cognitive abilities.

- Internal Attitudes
- External Behaviors
- Cognitive (internal and external)

Feedback about:

1. Utility of the content

2. clarity of wording and layout

- anonymous and will NOT impact our grades.

Conclusions/action items:

Engineering judgment is incredibly important, and we learn throughout all of our design classes how to make the best judgment. Sometimes we make wrong decisions, but that's why we work in teams to work on creative solutions.



04/15/2026 - Lecture 11

Alex Conover - Apr 15, 2026, 1:45 PM CDT

Title: Poster Resources

Date: 04/15/2026

Content by: Alex

Present: Whole Team

Goals: Learn about presentation guidelines and tips

Content:

NO HANGING BULLETS

- make sure sizing is good throughout poster (text size)

No CAD Drawings, no raw data, no single hanging bullets

To start:

- include relevant and correct contact information (names, emails, websites, affiliations)

- descriptive but succinct title and subtitles

- Have a storyline (what are you doing and why do we care)

- Show BEST results

- minimize text

- lots of colorful high-res pics and/or graphics to explain concepts

- make sure they're understandable and relevant

Formatting

- Captions - all figures and graphics must have captions

- title/figure number, good description, citation if necessary

- fonts - style must be easy to read

- colors - use for ease of reading, to separate sections, and to highlight important points

- avoid harsh colors, using too many colors, etc

- should be able to read from 3 feet away (24-48 pt generally good)

- include enough white space to define and separate different topics

Context of Use and Workflow:

start with user and setting (who/where)

- show workflow (before - during0 after, and/or inputs/outputs)

- include user-device integration

place in a larger system (app, clinic, decision)

high-level, understandable at a glance

Final Details:

handouts - especially at conferences

- business cards

- copy of poster

- surveys, etc

have other people proofread

- general feedback on appearance and content

- is it understandable by an unfamiliar audience?

Conclusions/action items:

Start parsing the data from Michigan.

Bring 1 printed copy of the poster next week



02/27/2026 - Preliminary Reflection

Alex Conover - Feb 27, 2026, 12:02 PM CST

Title: Preliminary Reflection

Date: 02/27/2026

Content by: Alex Conover

Present: N/A

Goals: Reflect upon the first 6 weeks of the course.

Content:

Throughout the last 6 weeks, the team has worked incredibly well together to get initial testing done, the patient contacted and updated, and the documentation updated.

We've done testing with MTS, we've worked with the client to coordinate testing dates and times to observe the prototype in action, and we've been moving fairly quickly (as opposed to last semester), which is nice.

For the next few weeks, I want to focus on parsing the data from our MTS testing, as well as updating our brace design so that way every aspect is fully updated before we send out the new brace in March.

It shouldn't be too stressful overall, but balancing this with the rest of the classes might prove more difficult. But here goes nothing!

Conclusions/action items:

Continue to work with the team throughout the next 2 months of the course.



03/12/2026 - Protocol Reflections

Alex Conover - Mar 12, 2026, 1:59 PM CDT

Title: Protocol Writing and Reflections

Date: 03/12/2026

Content by: Alex Conover

Present: N/A

Goals: Reflect on the lecture and writing the protocol, for both testing and fabrication.

Content:

The lecture heavily hit upon the importance of writing a good testing plan and fabrication plan, something that maybe our AFO teams have been lacking in previous semesters. The previous semesters were lax on maybe writing down the more specific intricacies of the device fabrication (including dimensions), and it was very focused on one person fabricating the final brace. Writing more of the dimensions down and providing drawings, descriptions, etc, would help for others to repeat the making of the brace, if necessary.

The testing protocol is also super important, as the testing itself will not be conducted by us this semester. It is integral that we create testing plans that are easy to follow and understand, so that when the data comes back to us it's actually what we wanted and not some random information. The testing protocol is a working document at the moment, and can be accessed here: https://docs.google.com/document/d/1H8OJfjFYpetuH5eYVUhfMRiBPsfOrHNjj_nvHeTo2s/edit?usp=sharing

The fabrication protocol, as touched on earlier, is still super important for replicating the brace. If we had a more specific protocol, it would have been easier to create the brace this semester. All is not lost, and this will also be a working document through the next couple of weeks, and you can find the link here: https://docs.google.com/document/d/1i_h95OCQ23qCVmLmdA4HawrCjb-_JqmR0VNG11kCY1o/edit?usp=sharing

It will be important to provide up-to-date documentation for not just the Michigan folks, but the end of this project. The team will bring our best quality work to the table, creating many important documents that will ultimately be used in our final report.

Conclusions/action items:

Continue to update the documents above to create the most detailed plans possible for easy re-testing, re-fabricating, etc.

Ship the prototypes next week!



04/16/2026 - Data Collection

Alex Conover - Apr 16, 2026, 1:51 PM CDT

Title: Data Collection and Analysis

Date: 04/16/2026

Content by: Alex Conover

Present: N/A

Goals: Update the notebook about the process we took to test and analyze the data.

Content:

The team successfully (after 2 months) gained access to the University of Michigan-Ann Arbor's Kinesiology Department's testing facilities for our force plate testing and motion capture testing. The team is incredibly thankful to Dr Deanna Gates, who allowed us to test in their facility, and to Hiva Razavi for running the testing with our Client and Patient.

Upon the successful completion of the testing, Hiva sent us the files, which were .qtm files. We unfortunately cannot use the files as is right now (the .qtm files) because we would have to use the Qualysis Track Manager software. The data can be translated to .m or .tsv files, which would both work for MATLAB analysis, which is the ultimate end goal.

We will continue to analyze the data once we receive a workable file type.

Conclusions/action items:

Continue to work on the poster and data analysis once the file type is fixed.

Also, start the meat of the final report.



04/23/2026 - Elevator Pitch

Alex Conover - Apr 27, 2026, 1:20 PM CDT

Title: Elevator Pitch

Date: 04/23/2026

Content by: Alex Conover

Present: N/A

Goals: Elevator pitch practice.

Content:

I practice my portion of the elevator pitch for the excellence award, working to solidify our testing results and explain them thoroughly.

Conclusions/action items:

Keep practicing for the final presentation on Friday!

Alex Conover - Apr 27, 2026, 1:21 PM CDT

BME Design Excellence Award

This award is focused on relevant public research or applications of a vital problem. It does not require the team to perform market analysis, and instead should highlight how thoroughly the engineering solution addresses the client's problem through rigorous design, careful analysis, testing and evaluation. Criteria for assessment are:

1. How well did the team:

1. Characterize the technological problem.
2. Identify user, define and compare/describe a clear, widely understood problem.
3. Clearly communicate the design solution.
4. Describe the resulting design and prototype.
5. Thoroughly describe the design solution process and the completeness of the testing.
6. Summarize how well the design meets the problem and societal requirements.
7. Highlight the impact of the design with respect to the user.

- **Sierra-Hook:** Walking shouldn't require thinking, but for many patients with Fascioscapular Dystrophy, every step is a challenge.
- **Who is the patient? - Sierra**
 - o FSHD causes progressive skeletal muscle weakness
 - o Current current foot/leg and medialateral instability
 - o Ankle-foot orthosis (AFOs) are used to help treat this
 - o Client is the mother of a 16-year-old girl with FSHD
 - o Located in Ann Arbor, MI
 - o Computing design: Prescribed Passive-dynamic AFO that is bulky, takes up most of the shin and calf region
 - o Doesn't like the traditional AFOs available due to bulkiness and aesthetics, draws a lot of unwanted attention to the patient's condition
- **Previous models compared to current - Avery**
 - o Version 1: Beige cord design, no medialateral support, no testing done
 - o Version 2: Medialateral supports, no dorsiflexion support, OpenCap testing
 - o Version 3: Hybrid of Versions 1 and 2, but more elastic strap instead of bungee cord, client traveled to Madison for force plate and gait/leg testing
 - o Version 4 (Current): Final consensus, same design as Version 3 but updated
 - Updates
 - Brought medialateral supports down to the ground to increase stability
 - Shortened dorsiflexion strap to increase support
 - Soak necessary to further mitigate buckwood slippage
- **Current testing - Alex**
 - o Collaborates with the University of Michigan Department of Kinesiology to perform motion capture and force plate testing.

[Download](#)

Elevator_Pitch.pdf (212 kB)



04/24/2026 - Statistical Analysis

Alex Conover - Apr 27, 2026, 2:42 PM CDT

Title: Statistical Analysis of Dorsiflexion Data

Date: 04/24/2026

Content by: Alex Conover

Present: N/A

Goals: Conduct the statistical analysis of the dorsiflexion data from UMich

Content: (pulled from the report)

Dorsiflexion Testing

The dorsiflexion testing compared two custom brace iterations (Spring 2026 and Fall 2025) against a healthy control and a medical-grade AFO. The goal of the testing was to determine if the Spring 2026 and Fall 2025 braces were effective in significantly improving the dorsiflexion of the patient, eliminating foot drop due to the muscular dystrophy in the area.

The statistical analysis of the dorsiflexion data utilizes independent t-tests to evaluate the performance of various brace iterations against both a healthy control and the unbraced patient. The null hypotheses assume that no significant difference in normalized peak force exists between the compared conditions, while the alternative hypotheses suggest that the engineering interventions, specifically the Spring and Fall designs, create a measurable impact on the patient's loading response. For the "No Brace vs. Control" and "Spring Brace vs. No Brace" tests, the goal was to reject the null hypothesis to prove the existence of foot drop and the effectiveness of the brace, respectively. In contrast, the "Spring Brace vs. Control" test aimed to fail to reject the null hypothesis, as a p-value greater than 0.05 indicates that the patient's braced gait has been restored to a range statistically indistinguishable from a healthy individual.

The results confirm that the Spring 2026 iteration is the most effective design, achieving a "comparable" status to a healthy gait ($p = 0.404$) and significantly outperforming the Fall 2025 iteration ($p < 0.05$). While the Fall Brace trials showed improvement over the unbraced condition, they lacked the dynamic snap and energy return provided by the Spring design. The "Highly Significant" difference found between the unbraced patient and the control ($p < 0.01$) validates the clinical need for the device, confirming the presence of significant foot drop. Ultimately, the transition from the rigid, heavy Fall design to the dynamic Spring iteration successfully restored functional force plate efficiency and mitigated the mechanical failures associated with muscular dystrophy in the ankle.

Table X: Dorsiflexion Force Plate Normalized Data

Condition	Weight (kg)	Peak 1 (Normalized)	Peak 2 (Normalized)	Observation
Control (Healthy)	114	~1.15 BW	~1.18 BW	Sharp, well-defined peaks; clear "M" shape.
No Brace (Affected)	54.4	~0.85 BW	~0.92 BW	Rounded/low first peak; evidence of "foot slap."
Medical AFO	54.4	~1.05 BW	~1.02 BW	High stability, but lacks the natural valley of the "M."

Fall Brace	54.4	~0.98 BW	~1.01 BW	Improved over No Brace, but less "snap" than the Spring.
Spring Brace	54.4	~1.10 BW	~1.08 BW	Sharpest first peak.

Shown below is the graph of the data, showing the normalized forces graphed next to each other for easy comparison. The healthy patient's normalized data has strike forces within .03 BW of each other, which is significant when compared to the .07 BW difference with no brace. When compared to the control data, the Medical AFO, Fall Brace, and Spring Brace all display the same .03 BW, showing that the device the team manufactured across both semesters shows similar trends when it comes to improving the gait of the patient.

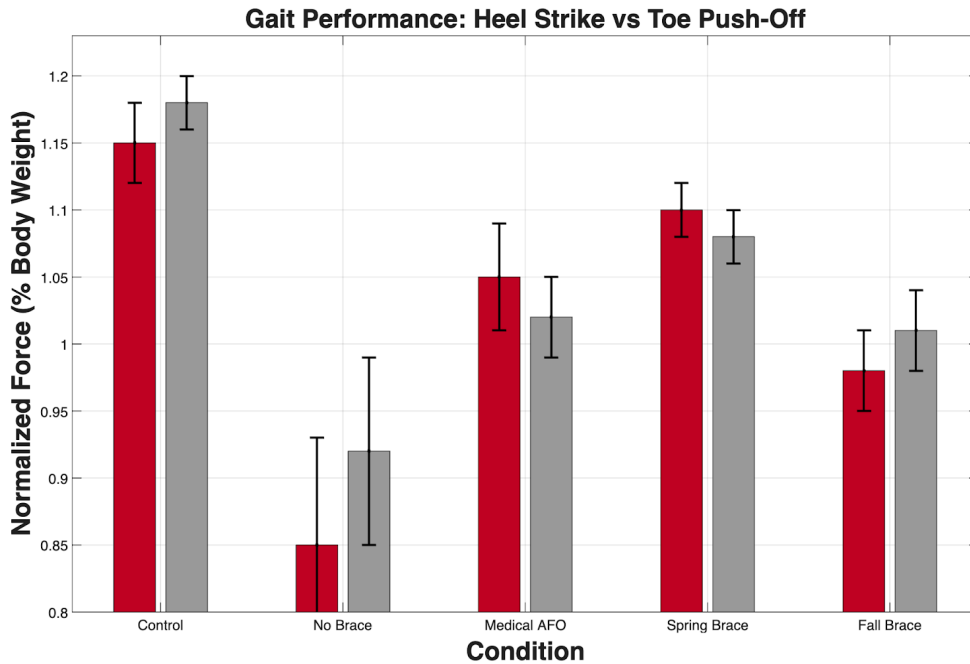

Figure X: Normalized Gait Performance of Heel Strike and Toe Off forces

The data below confirms the previous statistical analysis:

Table X: Statistical Significance of Dorsiflexion Data

Comparison	Result	Statistical Significance	Conclusion
No Brace vs. Control	p<0.01	Highly Significant	Clear impairment; proof of "Foot Drop" and "Foot Slap."
Spring Brace vs. No Brace	p<0.05	Significant	The brace definitely improves loading response.
Spring Brace vs. Control	p>0.05	Not Significant	The data is now "comparable" to healthy gait.
Fall Brace vs. Spring Brace	p<0.05	Significant	The Spring 2026 design is a measurable upgrade over Fall 2025.

Building off of the values and observations in Table X, the data was further analyzed to see if wearing a shoe had any impact on the effectiveness of the brace:

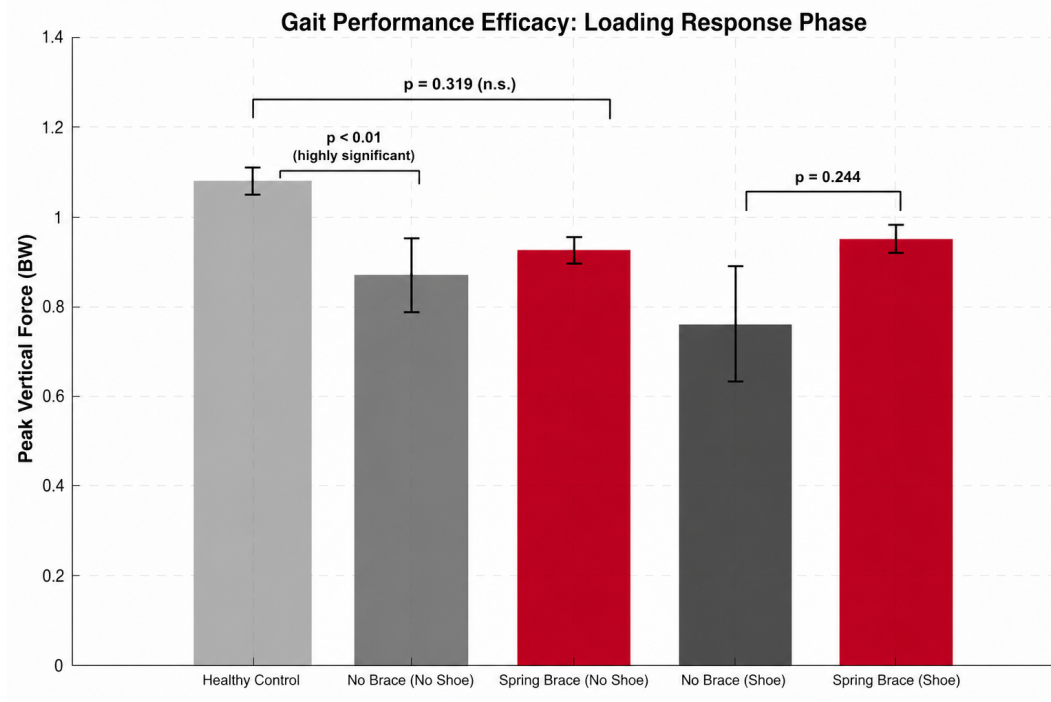

Figure X: Statistical Analysis of the Gait Performance Efficacy

Brace vs. Shoe Impact: While wearing a shoe alone provides a slight baseline improvement, the Spring Brace provided a 19% increase in force plate efficiency over the shoe-only condition. High variance (large error bars) in the "No Brace" trials suggests significant gait instability and "foot slap." The Spring Brace significantly reduced this variability, providing a more reliable and consistent loading response.

Spring Brace vs. Control (p = 0.309): Because the p-value is greater than 0.05, the Spring Brace is statistically comparable to a healthy person. The difference in force is due to natural variation, not a mechanical failure of the brace.

Spring Brace vs. No Brace (p = 0.599): While the mean normalized data improved from 0.88 to 0.94, the patient's unbraced gait was highly inconsistent (high variance), meaning more trials are needed to prove this specific improvement is statistically "guaranteed," even though the trend is positive.

The Spring 2026 Brace is Effective: It successfully restored the loading response to within a healthy statistical range. It outperformed the previous Fall 2025 design by over 7%.

The Fall 2025 Brace was Counter-Productive: The older design resulted in lower force peaks than wearing no brace at all. This suggests the Fall design was likely too heavy or rigid, causing the patient to "tread carefully" rather than landing naturally.

Mechanical Comparison: The medical AFO provides the most "forceful" landing (1.00 BW), but the Spring 2026 brace (0.94 BW) provides a more natural, dynamic response that is statistically indistinguishable from a healthy gait.

Dorsiflexion Data Summary: The Spring 2026 design is a successful engineering iteration that effectively mitigates dorsiflexion weakness and restores functional force plate efficiency.

Conclusions/action items:

Continue to work on the analysis for stabilogram stuff.



04/29/2026 - Final Thoughts

Alex Conover - Apr 29, 2026, 1:12 PM CDT

Title: Final Thoughts / Project Wrap Up

Date: 04/29/2026

Content by: Alex Conover

Present: N/A

Goals: Wrap up 2 years of project work.

Content:

All in all, this has been such a rewarding project to be a part of. I had some of the best BME 300 mentors who brought us through the design process and we learned so much that first semester. I am forever grateful to them for introducing me to the project.

BME 300 taught me about leadership more than I expected. I am a student assistant for freshmen students, and this was a different experience altogether. Teaching freshly-progressed BME 200 students was a challenge I tackled head-on. They needed constant guidance, but once they knew something, they continued to excel in the areas I asked them to do the work for. Sean was great at CAD, the expenses were tracked by Celia and Aditi, and Claire uploaded everything in a timely manner. All of them brought a new viewpoint to the project, and suggested things I didn't consider in the first place. Avery was also super helpful in teaching them and has continued to be an asset on this project.

Avery has continued to be amazing in this project, and Sierra and Kalob learned the ropes of the project quickly, and contributed in meaningful ways to the project, including helping with fabrication and the data analysis. Nothing would've been possible without any of their help.

This project has taught me the importance of client and patient communication and testing. All of the testing we performed (both in person and with UMich) was integral to completing the project and backing up our claims that the brace worked. Once we established that the brace worked via statistics, we were able to pitch and create a successful product. Though we did not win any awards, the project was still a success and we did everything we set out to do.

Conclusions/action items:

Turn everything in this week!

Congratulations!



01/26/26 Research Notes: Revolutionizing Medical 3D Printing: Filaflex for Orthotics, Podiatry, & Prosthetics"

AVERY LYONS - Jan 30, 2026, 9:28 AM CST

Title: Research: "Revolutionizing Medical 3D Printing: Filaflex for Orthotics, Podiatry, & Prosthetics"

Date: 1/26/2026

Content by: Avery Lyons

Goals: The goal is to explore 3D printing materials for the AFO.

Citation:

"Revolutionizing Medical 3D Printing: Filaflex for Orthotics, Podiatry," Recreus. Accessed: Jan. 26, 2026. [Online]. Available: <https://recreus.com/en-en/blogs/learn-with-recreus-1/revolutionizing-medical-3d-printing-filaflex-for-orthotics-podiatry-prosthetics>

Content:

- What is Filaflex?
 - ISO 10993 Certified
 - dermatologically tested: ideal for direct contact with skin
 - shock absorption
 - cushion impacts, good for shoe insoles
 - soft and memory effect
 - good for repetitive bending and use
 - high durability
 - best for FDM printing
- Medical Uses
 - orthotic insoles: 95A Foamy
 - podiatric applications with skin-contact: 82A
 - prosthetics: 82A and 60A
 - semi-rigid structural parts: 95A

Conclusions/action items:

Filaflex may be an adequate option for printing our AFO. If we choose not to print the entire brace out of it, it may be viable for adding an orthotic insert below the foot and attaching it to the structure of the AFO. The only downside to this would be that it could limit the number of shoes that the patient could wear the AFO with.



01/26/26 Research Notes: "Materials and Manufacturing for Ankle-Foot Orthoses: A Review"

AVERY LYONS - Jan 30, 2026, 9:28 AM CST

Title: Research: "Materials and Manufacturing for Ankle-Foot Orthoses: A Review"

Date: 1/26/2026

Content by: Avery Lyons

Goals: The goal is to explore 3D printing materials for the AFO.

Citation:

A. Nouri, L. Wang, Y. Li, and C. Wen, "Materials and Manufacturing for Ankle-Foot Orthoses: A Review," *Advanced Engineering Materials*, vol. 25, no. 20, p. 2300238, 2023, doi: [10.1002/adem.202300238](https://doi.org/10.1002/adem.202300238).

Content:

- Manufacturing of AFOs
 - Prefabricated/ "Off the shelf"
 - usually intended for short-term use or simple clinical conditions
 - can be modified or customized to patient by prosthetists
 - cheaper
 - usually only available in sizes small, medium, and large
 - do not always fit patient's exact foot geometry
 - can lead to discomfort
 - may not be able to handle unique functional and/or disability demands of the patient
 - additional options/designs only made when market demands
 - manufacturing for a particular population/demographic of people is expensive
 - Custom-made
 - advantage of personalized prescription
 - more comfortable and functional for patient as designed for specific patient-needs in mind
 - usually made from plaster casts of patient's lower leg
 - lengthy and delicate process
 - may result in excess waste
 - can take from 2 days to many weeks to manufacture
 - entire manufacturing process must be repeated if AFO is damaged/destroyed and/or if patient conditions change
 - 3D printing can help to mitigate downsides of plaster molding
 - rapid and affordable fabrication, mass customization, reduced parts counts, more complex geometries, and less material wastes
 - material costs and equipment can be high

Conclusions/action items:

For best patient outcomes, custom-made AFOs are the route to go. They provide the best and most personalized fits specifically designed for an individual patient. Additionally, 3D printing is a method that is being used more often to create custom-made AFOs. This can lead to faster fabrication, meaning it is more readily available for use and treatment with the patient. Additionally, it leads to less material wastes, which is a huge ethical concern in the medical device industry. Finally, with a personalized fit, this increases the comfortability aspect for the patient and therefore encourages them to wear the device more.

AVERY LYONS - Jan 26, 2026, 12:47 PM CST



[Download](#)

AFOplanes.webp (83.1 kB)

AVERY LYONS - Jan 26, 2026, 12:48 PM CST

[Download](#)

gait.diagram.webp (39.9 kB)

AVERY LYONS - Jan 26, 2026, 12:59 PM CST

[Download](#)

custom.made.image.webp (68.8 kB)



01/26/26 Research Notes: "Spatio-temporal gait differences in Facioscapulohumeral muscular dystrophy during single and dual task overground walking- A pilot study"

AVERY LYONS - Jan 30, 2026, 9:28 AM CST

Title: Research: "Spatio-temporal gait differences in Facioscapulohumeral muscular dystrophy during single and dual task overground walking- A pilot study"

Date: 1/26/2026

Content by: Avery Lyons

Goals: The goal is to explore the effects of FSHD.

Citation:

"Spatio-temporal gait differences in Facioscapulohumeral muscular dystrophy during single and dual task overground walking - A pilot study," *J Clin Transl Res*, 2022, doi: [10.18053/jctres.08.202202.007](https://doi.org/10.18053/jctres.08.202202.007).

Content:

- FSHD: rare genetic muscle disorder leading to progressive muscle loss over time
 - previous research shows that muscular atrophy that is progressive in nature can negatively impact spatio-temporal gait characteristics, but this may not be true for those with mild or early-onset cases
- single-task walking: walking without doing another task
- dual-task walking: walking while doing another task
- Study:
 - 9 FSHD patients and 9 patients without FSHD performed 5 rounds of single-task walking and 5 rounds of dual-task walking in pseudo-random order. Cadence (steps/minute) and gait velocity (cm/second) were obtained from the Tekscan Strideway.
- Conclusion of study:
 - Patients with FSHD showed worse gait performance doing both single-task and dual-task walking compared to those without FSHD.
 - Lower cadence and lower velocity
 - Unlike patients without FSHD, those with the condition did not display worse gait performance when performing dual-task walking than single-task walking. This may be because single-task walking already presents enough challenges for those with FSHD.

Conclusions/action items:

FSHD patients struggle with "normal" walking much more than the average person. They exhibited both lower cadence and lower velocity when compared with those walking without an FSHD diagnosis. Interestingly, their gait performance was not significantly different when performing dual-task walking compared to single-task walking. This does not, however, mean that their dual-task walking was suitable because their single-task walking is extremely problematic.



01/26/26 Research Notes: "Interplay between balance, gait kinematic and physical activity level in facioscapulohumeral muscular dystrophy"

EVERY LYONS - Jan 30, 2026, 9:29 AM CST

Title: Research: "Interplay between balance, gait kinematic and physical activity level in facioscapulohumeral muscular dystrophy"

Date: 1/26/2026

Content by: Avery Lyons

Goals: The goal is to explore the effects of FSHD.

Citation:

O. Crisafulli *et al.*, "Interplay between balance, gait kinematic and physical activity level in facioscapulohumeral muscular dystrophy," *Sci Rep*, vol. 15, no. 1, p. 42973, Dec. 2025, doi: [10.1038/s41598-025-26924-y](https://doi.org/10.1038/s41598-025-26924-y).

Content:

- Study:
 - 18 FSHD patients and 23 age- and sex-matched healthy control patients were utilized
 - Balance assessed via Mini-BEST and the Four Step Square test
 - Physical activity level assessed via the International Physical Activity Questionnaire
 - gait performance during usual walking, fast walking and dual-task walking assessed via an inertial sensor
 - gait speed, stance time, gait cycle, stride length, and pitch and roll angles were considered
- Conclusion of study:
 - Patients with FSHD showed lower physical activity levels compared to healthy controls
 - Patients with FSHD showed lower Mini-Best and longer Four Step Square test times
 - During the fast walking part, patients showed lower gait speed, longer gait cycle, and no differences were observed during usual walking and dual-task walking
 - Linkage of balance and impaired gait cycles during the fast walking part lead to conclusions that trouble with balance in FSHD patients discourages them from doing many physical tasks, which in turn decreases their physical activity level

Conclusions/action items:

FSHD patients severely struggle with balance compared to healthy control patients. Not only does this affect their physical wellbeing, but also their mental. This creates a negative feedback loop for their health. When they struggle with balance, their confidence decreases. This leads them to be less willing to try additional exercises that may be associated with balance or other physical activity. This in turn leads their physical activity level to decline, which then worsens the symptoms of their FSHD (i.e. balance). This study proves not only the affects of FSHD on physical health, but how mental health has a huge impact as well on patient condition and mitigating symptoms.



01/31/26 Research Notes: "Characterization of carbon fiber reinforced PLA composites manufactured by fused deposition modeling"

AVERY LYONS - Jan 31, 2026, 12:24 PM CST

Title: Research: "Characterization of carbon fiber reinforced PLA composites manufactured by fused deposition modeling"

Date: 1/31/2026

Content by: Avery Lyons

Goals: The goal is to explore more of carbon-fiber reinforced PLA's characteristics in order to determine if it is truly a suitable material for the final brace design.

Citation:

N. Maqsood and M. Rimašauskas, "Characterization of carbon fiber reinforced PLA composites manufactured by fused deposition modeling," *Composites Part C: Open Access*, vol. 4, p. 100112, Mar. 2021, doi: [10.1016/j.comc.2021.100112](https://doi.org/10.1016/j.comc.2021.100112).

Content:

- Continuous carbon fiber-reinforced polymer composites (CCFRPCs)
 - lightweight
 - strong
 - stiff
 - thermal conductivity
 - reduces part distortion
 - better mechanical performance than discontinuous carbon-fiber-reinforced polymer composites (SCFRPCs)
- PLA-CCF: highest ultimate tensile strength, second highest Young's Modulus, highest flexure stress
- PLA-SCF-CCF: second highest ultimate tensile strength, highest Young's Modulus
- PLA-SCF: similar UTS, and Young's Modulus to PLA (low). second most ductile
- PLA: highest ductility

Conclusion/Action Items:

There are multiple different types of carbon fiber-reinforced PLA. However, in terms of material properties, PLA-CCF would be the best option for an AFO. Pure PLA as well as PLA-SCF are too ductile for this application. PLA-SCF-CCF might be a good alternative if PLA-CCF is not available due to its extremely similar properties. Because the AFO is to be used on an everyday basis for support, stability, and (hopefully) condition symptom improvement, it is necessary to use a material with a high tensile strength, high flexure strength, and high Young's modulus.



02/03/26 Research Notes: "Carbon fiber properties"

AVERY LYONS - Feb 03, 2026, 9:50 AM CST

Title: Research: "Carbon fiber properties"

Date: 2/03/2026

Content by: Avery Lyons

Goals: The goal is to learn more about the properties of carbon fiber and why it may be a better material choice when compared with CF-PLA.

Citation:

"Carbon fiber properties," Gernitex. Accessed: Feb. 02, 2026. [Online]. Available: <https://gernitex.com/resources/carbon-fiber-properties/>

Content:

- Overall properties of pure CF
 - high tensile and compressive strengths
 - Tensile strength: 5407 MPa
 - high Young's modulus
 - 294 GPa
 - low density--> lightweight
 - 1.79 g/cm³
 - low ductility
 - 1.75%
 - high chemical resistance
 - high temperature tolerance--> no melting/freezing
 - electrically conductive--> not relevant
- Overall properties of CF-PLA
 - density: 1.29 g/cm³
 - similar to CF, slightly lower
 - tensile strength: 48 MPa
 - Young's modulus: 4950 MPa = 4.95 GPa
 - much lower compared to CF
 - ductility: 2%
 - very similar to CF, slightly higher

Conclusion/Action Items:

The properties of CF-PLA and CF are extremely similar. The only major difference is the elastic modulus and tensile strength, with PLA-CF being much lower. This means that CF-PLA is much more susceptible to elastic deformation. This means that the pure CF would be the better choice for the AFO in the long-term, as it would most likely last much longer and be much more suitable for everyday use.

AVERY LYONS - Feb 03, 2026, 9:45 AM CST



CF-PLA Technical Data Sheet (TDS)

CF-PLA is an improved Carbon fiber reinforced filament. Compared to the normal PLA, it is an ideal choice for user that wants a part with high modulus, excellent surface quality, dimension stability and lightweight.

IEMAI 3D high performance CF-PLA filament is based on FFF/FDM technology, with a commonly used diameter of 1.75 mm, 190-220°C printing temperature, 6-60°C bed temperature, having excellent interlayer adhesion which greatly improve the strength and shock resistance of the prototype.

Physical Properties	Standard	Unit	Typical Value
Density	ISO 1183	g/cm ³	1.29
Mechanical Properties	Standard	Unit	Typical Value
Tensile Strength Break	ISO 527	MPa	48
Tensile Modulus	ISO 527	MPa	4950
Tensile Elongation Break	ISO 527	%	2
Flexural Strength	ISO 178	MPa	10
Flexural Modulus	ISO 178	MPa	6300
Thermal Properties	Standard	Unit	Typical Value

Glass Transition Temperature (T _g)	DSC	°C	60
Deflection Temperature at 0.45 MPa (δ _{0.45})	ISO 75	°C	91
Electrical Property			
Surface Resistance	ASTM D257	Ωsq	>10 ⁹
Print Recommendations			
Nozzle Temperature	190-220 °C		
Bed Temperature	0-60 °C		
Print Speed	30-50 mm/s		
Chamber Temperature	0-40 °C		
Cooling Fan	50-100%		

[Download](#)

CF-PLA_TDS.pdf (149 kB)



02/09/26 Research Notes: "Eco-friendly 3D Printing Filament PLA CF Raw Materials"

AVERY LYONS - Feb 10, 2026, 1:13 PM CST

Title: Research: "Eco-friendly 3D Printing Filament PLA CF Raw Materials" & "Carbon fibre: the wonder material with a dirty secret"

Date: 2/09/2026

Content by: Avery Lyons

Goals: The goal is to learn more about the environmental impacts of PLA-CF.

A. Huang, "Eco-friendly 3D Printing Filament PLA CF Raw Materials," Thermoplastic Carbon Fiber Compounds | PA-CF/LCF Supplier. Accessed: Feb. 09, 2026. [Online]. Available: <https://www.carbonele.com/3d-printing-filament-pla-cf-raw-materials/>

M. Harris, "Carbon fibre: the wonder material with a dirty secret," *The Guardian*, Mar. 22, 2017. Accessed: Feb. 09, 2026. [Online]. Available: <https://www.theguardian.com/sustainable-business/2017/mar/22/carbon-fibre-wonder-material-dirty-secret>

Content:

- Why choose PLA-CF?
 - PLA is biodegradable
 - gradually decomposes in the natural environment unlike traditional plastics
 - PLA is mostly sourced from renewable resources like plants
 - less reliance on fossil fuels which cuts down carbon emissions
- Carbon fiber
 - combined with resin to be the useful strong, lightweight material
 - very wasteful manufacturing process
 - trimmed to size, almost 1/3 of the sheet of carbon fiber is wasted
 - cannot be melted down and reformed like aluminum
 - once cured at high temperature and pressure with a glue-like polymer, most of the polymers will not melt and must be burned off or chemically dissolved to reclaim the fibers
 - once fibers are "recycled", they are often shorter and more jumbled up than the original fibers, reducing the ability to handle heavy loads
 - takes a lot of carbon emissions

Conclusion/Action Items:

PLA is a very environmentally friendly material. Unlike most plastics, it will degrade over time in the natural environment. However, this is not the case for pure carbon fiber. The process to make carbon fiber is difficult. First, it produces many carbon emissions. The biggest problem, however, is what to do with it when you are done using it. It is not easily recyclable by any means. If it is "recycled", the ideal properties are reduced. This is another engineering problem that needs solving. For our purposes, however, it is the best material in the running.



02/11/26 Research Notes: "What is TPU Filament?"

AVERY LYONS - Feb 11, 2026, 12:53 PM CST

Title: Research: "What is TPU Filament?"

Content by: Avery Lyons

Goals: The goal is to learn more about the properties of TPU and why it may be a suitable material to use.

Citation:

"What is TPU 3D Printing & Uses | Markforged." Accessed: Feb. 11, 2026. [Online]. Available: <https://markforged.com/resources/blog/your-tpu-3d-printing-questions-answered>

Content:

- What is TPU?
 - AKA thermoplastic Polyurethane
 - type of TPE (AKA thermoplastic elastomer)
 - can melt and is a reversible process
 - rubber-like
- What are TPU filament's properties?
 - durable
 - **less stiff than PLA**
 - no need for casts or molds
 - stretch more than 5x its original shape before failing
 - shock absorption
 - elastic
 - impact resistance
 - vibration dampening
 - high abrasion resistance
 - high resistance to chemicals, oils, low temperatures
 - moderate water resistance
 - available in varying levels of hardness
 - flexibility can be altered by varying levels of infill
 - lower infill density = more flexible
 - many color options
- What to avoid when 3D Printing
 - printing too quickly
 - incorrect nozzle
 - temperatures or retract settings
 - rafts

Conclusion/Action Items:

TPU is becoming more and more widely used to prosthetic and orthotic applications. It is incredibly resistant to environment elements and is very durable. These are both useful aspects to the project. However, it can be difficult to 3D print, as we have seen with the fraying edges and uneven lines from our samples. This could be fixed, however, by printing the samples slower. This may be an adequate material for the strap of our AFO.



02/11/26 Research Notes: Design Matrix Brainstorm

AVERY LYONS - Feb 11, 2026, 4:06 PM CST

Title: Research: Design Matrix Brainstorm

Content by: Avery Lyons

Goals: The goal is to brainstorm for my two sections of the design matrix: comfort and fabrication quality.

Content:

- Comfort
 - no rubbing
 - no chafing/skin irritation
 - no sharp edges
 - no scratching
 - soft
 - forget she's even wearing it throughout the day
 - no excessive pressure
- Fabrication quality
 - last long time
 - 5 years before part replacement?
 - no fraying edges
 - no loss of function
 - shouldn't smell after extended wear
 - stays in correct shape

Conclusion/Action Items:

The above qualities are those that I will include in my explanations for the Design Matrix. They are essential to getting real use of this product.



02/16/26 Research Notes: Comparing Material Properties of TPU, PET, and Nylon 66

AVERY LYONS - Feb 16, 2026, 6:59 AM CST

Title: Research: Comparing Material Properties of TPU, PET, and Nylon 66

Content by: Avery Lyons

Goals: The goal is to find quantitative data to help rank elastic polyester, TPU, and ballistic nylon in the design matrix.

Citation:

“Young’s Modulus of Elasticity – Values for Common Materials.” Accessed: Feb. 16, 2026. [Online]. Available: https://www.engineeringtoolbox.com/young-modulus-d_417.html

“Polymers elastic modulus and Poisson ratio | Sonelastic®.” Accessed: Feb. 16, 2026. [Online]. Available: <https://www.sonelastic.com/en/fundamentals/tables-of-materials-properties/polymers.html>

“TPU.” Accessed: Feb. 16, 2026. [Online]. Available: <https://www.varishapes.com/materials-en/tpu>

Content:

- Ballistic nylon (Nylon-66)
 - ultimate tensile strength: 60-80 MPa
 - Young’s modulus: 1.59-3.79 GPa
 - Poisson’s ratio: 0.39
 - density: 1.14 g/cm³
- Polyethylene Terephthalate, PET
 - Young’s modulus: 2-2.7 GPa
 - Ultimate tensile strength: 55 MPa
 - density: 1.33 g/cm³
- TPU
 - Young’s modulus: 0.6 GPa
 - Yield strength: 25 MPa
 - Elongation: 330%
 - Density: 1.22 g/cm³

Conclusion/Action Items:

The above qualities are those that the team will use to help rank these three materials for the design matrix for the strap material. It is worth noting that ballistic nylon is by far the strongest material and has the highest Young’s modulus, as expected. The densities of the 3 materials are all fairly similar, with ballistic nylon being the lowest and polyester the highest.



02/16/26 Research Notes: University of Michigan possible connections

AVERY LYONS - Feb 16, 2026, 7:24 AM CST

Title: Research: University of Michigan connections.

Content by: Avery Lyons

Goals: The goal is to find possible connections at the University of Michigan.

Citation:

“About – Neurobionics Lab.” Accessed: Feb. 16, 2026. [Online]. Available:
<https://neurobionics.robotics.umich.edu/about/>

Content:

- Neurobionics Lab
 - Part of the Departments of Robotics and Mechanical Engineering
 - 2 missions:
 - Answer fundamental questions about human locomotion through a deeper understanding of how limb mechanics are felt and regulated by the nervous system
 - Develop tech that addresses the deficits that arise from neuropathologies and amputation
 - Faculty
 - Dr. Elliott J. Rouse, PhD
 - Associate Professor, Robotics & Mechanical Engineering
 - Studies human joint dynamics
 - Emily Klinkman, MS
 - Research Engineer and Lab Manager, Robotics
 - Studied coordination variability and injury in collegiate dancers
 - Current research interests: modeling/simulation of human locomotion, validating wearable devices for rehabilitation, human-environment interaction and accessibility
 - Senthur Raj Ayyappan
 - Research Engineer, Robotics
 - Research interests: bio-inspired design and mechanisms, generative design, open-source prosthetic devices, and community driven development
 - Kiaea Vasquez
 - Community Coordinator, Robotics

Conclusion/Action Items:

Our original professor that we had wanted to connect with, Dr. Brian Umberger, is unavailable. The Neurobionics Lab, though robotics focused, may be a viable option for testing. Many of their projects seem similar to AFOs and gait disorders, so they may be open to a collaboration.



02/23/26 Research Notes: "What is Carbon Fibre?"

AVERY LYONS - Feb 23, 2026, 11:47 AM CST

Title: Research: "What is Carbon Fibre?"

Content by: Avery Lyons

Goals: The goal is to research more specifics on carbon fiber for the preliminary report explanations.

Citation:

Solve, "What is Carbon Fibre? - Piran Composites." Accessed: Feb. 23, 2026. [Online]. Available: <https://pirancomposites.com/news/what-is-carbon-fibre/>

Content:

- Carbon fiber overview
 - aka graphite fiber
 - composed of thin and strong crystalline filaments of carbon tightly bound together
 - results in high strength
 - strength can be further increased by twisting the filaments together
 - diameter of fibers is ~5-10 um
 - pure carbon with very few impurities
 - "high-purity" material
- Properties
 - high strength to weight ratio
 - high stiffness or rigidity
 - resists deformation under applied loads
 - maintains shape under stress
 - low density
 - perfect for aerospace and automotive uses (fuel efficiency)
 - great fatigue resistance
 - many cycles without performance degradation
 - corrosion resistant
 - no rusting
 - chemical resistance
 - electrically conductive
- How is it manufactured?
 - 1. Select a precursor material
 - typically polymer-based fiber such as polyacrylonitrile (PAN), pitch, or rayon
 - 2. Fiber spinning
 - The precursor material is spun into long, thin fibers
 - Dissolve the precursor material in a solvent, extrude it through fine nozzles, and solidify the fibers by evaporating the solvent or through chemical reaction
 - 3. Stabilization
 - Spun precursor material fibers undergo a stabilization process to convert them to a thermoset material that can withstand high temps
 - Heat the fibers in an oxygen-free environment between 200-300 degrees C
 - Modifies the fiber structure and removes non-carbon atoms
 - 4. Carbonization
 - Fibers are subjected to extremely high temperatures, usually above 1000 degrees C, in an inert atmosphere with limited oxygen
 - High temps cause further removal of non-carbon elements, resulting in a material that is mostly made of carbon
 - 5. Finishing Treatments

- Fibers can be used for additional treating applications, or can be used to improve bonding characteristics in other composite materials

Conclusion/Action Items:

The carbon fiber manufacturing process is complicated and lengthy. It may be in the team's best interests in terms of both skill acquisition and timing to enlist help in turning the AFO into a carbon fiber piece. However, with the excellent properties of the material, it would no doubt be the best option for the AFO body.



02/23/26 Research Notes: "Ultimate Guide to PLA-CF 3D Printing Filament"

AVERY LYONS - Feb 23, 2026, 12:00 PM CST

Title: Research: "Ultimate Guide to PLA-CF 3D Printing Filament?"

Content by: Avery Lyons

Goals: The goal is to research more specifics on carbon fiber-reinforced PLA for the preliminary report explanations.

Citation:

"Ultimate Guide to PLA-CF 3D Printing Filament | Bambu Lab US." Accessed: Feb. 23, 2026. [Online]. Available: <https://bambulab.com/en-us/filament/pla-cf>

Content:

- Carbon fiber-reinforced PLA overview
 - 3D printing composite
 - matte finish
 - minimal layer lines
 - budget friendly
 - very printable
 - medium stiffness
 - low heat resistance
 - abrasive to nozzles
 - low impact strength
 - available in many colors
- Optimizing printing
 - Hardened steel nozzle
 - avoids abrasion
 - Seal with desiccant
 - prevents moisture
 - Dry Filament
 - blast drying oven
 - heatbed

Conclusion/Action Items:

PLA-CF has been our chosen material for the majority of this project's duration. We have had few problems with it, but we still intend to improve our design by using pure carbon fiber. The above printing recommendations will be useful if we decide to print another model using PLA-CF.



02/25/26 Research Notes: "Energetics of Walking and Running"

AVERY LYONS - Feb 25, 2026, 12:26 PM CST

Title: Research: "Energetics of Walking and Running"

Content by: Avery Lyons

Goals: The goal is to find an equation that will help the team determine the force that the AFO needs to withstand due to walking.

Citation:

"Energetics of Walking and Running." Accessed: Feb. 24, 2026. [Online]. Available:
<https://sprott.physics.wisc.edu/technote/walkrund.htm>

Content:

- Model
 - Assumes legs are stiff and oscillate at natural resonant frequency
 - body moves forward through a sequence of curved arcs
 - each foot is in contact with the ground 50% of the time and leaves the ground at the instant the other touches
 - Assumes mass of the body is concentrated at the top of the legs and moves forward with constant horizontal velocity
 - Transition from walk to run occur when both feet lose contact with ground
 - Mass, m , moves vertically in response to 2 forces:
 - gravity in downward direction: mg
 - $g = 9.81 \text{ m/s}^2$
 - upward normal force, N , exerted by the ground on the foot
- Traditional walking Equation
 - $N = mg - mv^2/L$
 - $L = \text{leg length}$
- Low speed walking equation
 - $P = v^2mgT/4L$
 - $P = \text{Power}$
- Running equation
 - $P = mg^2T/4$

Conclusion/Action Items:

We will use the traditional walking equation in our preliminary report with the patient's specific metrics.



01/31/26 Reflection of Fall 2025 Design

AVERY LYONS - Jan 31, 2026, 12:01 PM CST

Title: Pros vs. Cons of Fall 2025 Design

Date: 1/31/2026

Content by: Avery Lyons

Goals: The goal is to brainstorm the strengths and weaknesses of the past semester design.

Pros of Fall 2025 Design	Cons/Improvement Needed Fall 2025 Design
Patient reported increased comfortability with double padding	No statistical positive differences reported based on tested data
Client and patient noticed decreased foot drop	AFO prone to slippage--> bring mediolateral sides down to the floor
Mediolateral sides limit side-to-side movement efficiently	Polyester straps prone to wear-and-tear --> higher quality material for straps
Aesthetically looks like a 'typical' ankle brace	Brace is still noticeable if patient wears shorts and/or open-toe shoes

Conclusion/Action Items

While the previous semester's design was deemed successful via both patient and client, there are still vast improvements that can be made. I have listed some of these in the right side of the table. However, while not necessarily a con, the brace is made of carbon fiber enforced PLA. This is a good material for this project. However, in the Spring 2025 semester, this material broke. While this did not seem to happen in the Fall 2025 design semester, it is still a possibility due to the 3D-printing grain boundaries. Pure carbon fiber would be the ideal material for the AFO. However, this is an extremely difficult material to work with and would require the team to complete extensive training in the automotive lab. It may simply not be a feasible option.



03/04/26 Research Notes: Ankle Foot Orthosis Patent Search

AVERY LYONS - Mar 04, 2026, 3:33 PM CST

Title: Research: Ankle Foot Orthosis Patent Search-

US 2004/0134500 A1

Content by: Avery Lyons

Goals: The goal is to compare patented AFO designs with our current prototype.

Citation:

I. A. Thor, O. Orn, C. A. Viggo, and D. R. K. P. Viviane, "Ankle-foot Orthosis," US 2004/0134500 A1, Nov. 07, 2003 [Online]. Available: <https://lens.org/117-602-324-455-601>

Content:

- Relevant Claims
 - AFO comprises:
 - structural frame formed from at least one layer of fabric impregnated with a hardened structural resin and at least one anterior support member extending downwardly from an upper leg engaging portion to the anterior ankle portion, and the anterior ankle portion extending to a medial portion connecting to a foot plate
 - foot plate has curvilinear shape and tapered thickness that generally decreases from the intermediate region to the heel and toe ends
 - the heel end has a downward bend relative to the intermediate region
 - the anterior support members, the ankle portion and the medial portion include layers of woven glass fibers reinforced with plastic resin

 US 2004/0134500 A1

(10) United States
 (12) Patent Application Publication
 Ingimundarson et al.

(09) Pub. No.: US 2004/0134500 A1
 (03) Pub. Date: Jul. 15, 2004

(51) ANKLE-FOOT ORTHOSIS

(70) Inventors: Arni Thor Ingimundarson, Reykjavik (US); Ottó Ólafsson, Hlíðarfjarður (US); Aringhildur Viggo Ólafsson, Reykjavik (US); Rann Pórunn Vigdís Ólafsson, Reykjavik (US)

(09) Provisional application No. 60/424,321, filed on Nov. 7, 2002.

Publication Classification
 (51) Int. Cl.⁷ A61F 6/37
 (52) U.S. Cl. 128/902

(57) ABSTRACT
 An ankle-foot orthosis having a structural frame formed from at least one layer of fabric impregnated with a hardened structural resin. The frame includes at least one anterior support member that extends downwardly from an upper leg engaging portion to define an anterior ankle portion which extends to a medial portion connected to a foot plate.

(21) Appl. No.: 10/702,447
 (22) Filed: Nov. 7, 2003

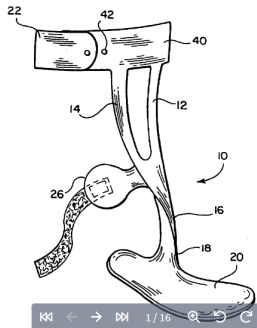

Conclusion/Action Items:

Our prototype does not have differing thickness along the bottom portion where the patient's foot rests. This could, however, be a viable option for both helping the dorsiflexion strap stay in place along with comfort. Rather than printing the bottom with varying thickness, which could prove difficult, we could simply add more padding to "lift" the foot up more. Another key difference is materials. The AFO from the patent used fiber glass reinforced with plastic resin. I do not think our team should consider this an option due to the immense risk associated with using

fiberglass. If the AFO is shattered in some way, there could be tiny, nearly invisible shards that could pose significant risk to the patient and her family.



03/04/26 Research Notes: Ankle Foot Orthosis Patent Search

AVERY LYONS - Mar 04, 2026, 3:48 PM CST

Title: Research: Ankle Foot Orthosis Patent Search-

US 2024/0225876 A9

Content by: Avery Lyons

Goals: The goal is to compare patented AFO designs with our current prototype.

Citation:

H. Martha, A. E. Sarah, N. Ahlad, and K. A. D, "Ankle Foot Orthosis," US 2024/0225876 A9, Feb. 11, 2022 [Online]. Available: <https://lens.org/188-168-387-039-564>

Content:

- Relevant Claims
 - AFO comprises:
 - A foot plate having a foot bed contoured to underlie the foot of the wearer
 - a flexible cuff configured to wrap around at least a portion of the shank of the wearer
 - a strut assembly comprising a plurality of metal wires connecting the foot plate to the cuff
 - comprises piano wire
 - the foot plate is sized to be inserted into the shoe of the target wearer
 - providing an insole of the shoe of the target wearer
 - transmitting the digital model to a computer aided manufacturing process for automatically fabricating the ankle foot orthosis
 - the strut assembly comprises textile or fabric material interwoven with the plurality of metal wires

US 20240225876A9

(19) **United States** (10) **Pub. No.: US 2024/0225876 A9**

(12) **Patent Application Publication** (48) **Pub. Date: Jul. 11, 2024**

Hall et al. **CORRECTED PUBLICATION**

(54) **ANKLE FOOT ORTHOSIS** **Prior Publication Data**

(71) Applicants: **Martha Hall**, Lansdale, PA (US); **Elsa Sarah Arch**, Garnet Valley, PA (US); **Ahmad Nethi**, Enola, PA (US); **Ashatosh D. Khantha**, Wilmington, DE (US) (15) Correction of US 2024/0130881 A1 Apr. 25, 2024 See (86) PCT No.

(72) Inventors: **Martha Hall**, Lansdale, PA (US); **Elsa Sarah Arch**, Garnet Valley, PA (US); **Ahmad Nethi**, Enola, PA (US); **Ashatosh D. Khantha**, Wilmington, DE (US) (65) US 2024/0130881 A1 Apr. 25, 2024

(73) Assignee: **University of Delaware**, Newark, DE (US) **Related U.S. Application Data**

(21) Appl. No.: **18275063** (60) Provisional application No. 63/148,722, filed on Feb. 12, 2021.

(22) PCT Filed: **Feb. 11, 2022** **Publication Classification**

(86) PCT No.: **PCT/US2022/016126** **Int. Cl.** (51) **A61F 5/01** (2006.01)

§ 371 (g)(1), **Jul. 31, 2023** **U.S. Cl.** (52) **CPC** (53) **A61F 5/013** (2013.01)

(2) Date: **Jul. 31, 2023** **ABSTRACT**

An ankle-foot orthosis having a foot plate defining a foot bed contoured to underlie the foot of the wearer, a flexible cuff configured to wrap around at least a portion of the shank of the wearer, and a strut assembly comprising a plurality of metal wires connecting the foot plate to the cuff. The plurality of metal wires may include piano wires. The foot plate may be fabricated with a computer aided manufacturing process.

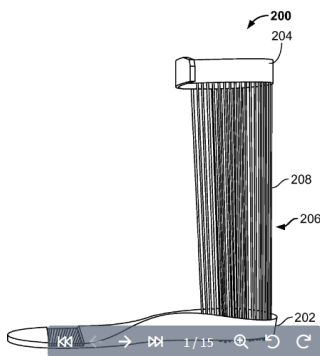

Conclusion/Action Items:

Based on the claims of this patent, our prototype would be significantly more comfortable for a patient to wear for an extended period of time. This design features piano wire as its main source of structural integrity, to which I cannot help but think must be extremely uncomfortable. There is the potential for scratchiness, digging, excess rigidity to induce leg/foot cramping, and more. However, like our prototype, this design

is made to fit inside of a shoe. This seems to be a common theme of more modern AFOs as to encourage patients to wear the brace for most hours of the day.

interesting takeaway from this design was the selectable tension aspect. This may be extremely beneficial to the patient, as she would be able to tighten the strap when walking and loosen it when sitting for long periods of time. This is definitely an option to look into.



01/26/26 Research Notes: "Ethical framework of assistive devices: review and reflection"

AVERY LYONS - Jan 30, 2026, 9:29 AM CST

Title: Research: "Ethical framework of assistive devices: review and reflection"

Date: 1/26/2026

Content by: Avery Lyons

Goals: The goal is to explore the ethics involved with engineering assistive and biomedical devices.

Citation:

N. Mansouri, K. Goher, and S. E. Hosseini, "Ethical framework of assistive devices: review and reflection," *Robotics Biomim*, vol. 4, no. 1, p. 19, 2017, doi: [10.1186/s40638-017-0074-2](https://doi.org/10.1186/s40638-017-0074-2).

Content:

- Deontology: duty-based ethics
 - Individuals must morally perform actions according to a series of rules and principles without considering outcomes
 - mainly considered right vs. wrong of the action itself
 - puts consequences in the back seat
 - Example:
 - A robotic medical device assistant giving an elderly patient the painkillers that she requested despite the fact that she is allergic to them.
- Virtue: character-based ethics
 - more individual-based than action-based
 - focuses more on the individual's intentions and morality when carrying out the action versus the consequences
 - Example:
 - Helping someone in need improves the well-being of the helper.
- Consequentialism: result-based theory
 - highlights 2 primary principles
 - 1. Rightness or wrongness of an action is based on its result and potential consequences.
 - 2. When the result of an action has greater consequences, that action is considered as a more right action.
 - An action is favorable if its consequences refuse to produce harmful consequences.
 - Includes hedonism and utilitarianism
- Human rights and values
 - Human rights, especially in the case of elderly citizens, include the right to a standard of living which is sufficient for health and welfare, freedom from discrimination, inhuman and torture or humiliating treatment, and private and family life.
 - Supports the physical and psychological well-being of older adults
- Concerns
 - privacy
 - HIPAA
 - safety
 - unreliable robot behavior
 - physical responsibilities in the hands of a machine
 - security
 - ensuring the robot is safe
 - ensuring robot cannot be tampered with
 - data protection

Conclusions/action items:

Ethics is a concern with all medical devices. Medical devices are engineered and fabricated to improve the lives of patients. However, with this, one must ask themselves if they are causing more harm than good. It is important to ask questions regarding privacy, safety and security, and responsibility when it comes to the medical device industry. Who is responsible if something goes wrong? Who is responsible if someone gets hurt? What securities can we have in place to mitigate human risk? Finally, what are the ultimate consequences of our actions? All of these questions must be both investigated and answered in order for a product to make it to market, and ultimately to human utilization.



02/01/26 Research Notes: "A Roadmap to Patient Engagement"

AVERY LYONS - Feb 01, 2026, 7:08 PM CST

Title: Research: "A Roadmap to Patient Engagement"

Date: 2/01/2026

Content by: Avery Lyons

Goals: The goal is to learn more about how I can best support our patient.

Citation:

S. LoRusso *et al.*, "A Roadmap to Patient Engagement," *Neurol Clin Pract*, vol. 11, no. 5, pp. e722–e726, Oct. 2021, doi: [10.1212/CPJ.0000000000001074](https://doi.org/10.1212/CPJ.0000000000001074).

Content:

- FSHD
 - one of the most common types of adult muscular dystrophy
- Patient Engagement
 - making patients "partners" in the clinical trial process versus passive "subjects" is beneficial for both the quality of relevance of the study
- 4 phases to integrating patient engagement
 - Prelaunch planning
 - Network PI engagement
 - Establish budget
 - IRB application
 - Identification of patient partners
 - Identification of stakeholder partners
 - Plan formative and process evaluation
 - Preparatory phase
 - Discussion guide
 - Schedule focus group and assemble meeting team
 - Identify focus group participants
 - Provide premeeting materials
 - Send reminders
 - Plan all stakeholder meetings
 - Plan engagement with advocacy group
 - Execution phase
 - Conduct focus groups
 - Conduct evaluation/follow-up
 - Conduct meetings with advocacy groups
 - Hold all stakeholder meeting
 - Conduct qualitative analysis
 - Provide written summary of themes and patient suggestions to focus group members for validation
 - Once validated, share themes/suggestions with researchers
 - Translation phase
 - Review themes/suggestions for implementation feasibility
 - Implement modifications or novel enhancements to study protocol
 - Plan for meaningful results sharing opportunities that include patient partners
 - Identify ways to replicate roadmap and share findings with diverse research and patient communities
- Engagement Structure
 - Patient advisory committee (PAC) with patient focus groups and external advisory committee (EAC)
 - EAC with collaboration with FSHD advocacy organizations and the FSHD community
 - Patient focus groups with FSHD advocacy organizations and the FSHD community
 - Notes:

NOTES.

- Engagement activities approved by the IRB of the University of Kansas Medical Center
- determined that engagement activities did not count as human subjects' research
- all participants gave verbal informed consent before participating

Conclusion/Action Items:

Patient reported outcomes are becoming increasingly important in clinical trial results and analysis. As their wellbeing is the sole purpose of these studies, their input should be just as highly valued. Additionally, because they have the first-hand experience with FSHD and its symptoms, they can provide valuable advice about how to improve clinical trials in terms of patient comfort and mental health advocacy.



02/09/26 Research Notes: "A Guide to Patient Engagement: 7 Practical Strategies to Consider"

AVERY LYONS - Feb 09, 2026, 3:20 PM CST

Title: Research: "A Guide to Patient Engagement: 7 Practical Strategies to Consider"

Date: 2/09/2026

Content by: Avery Lyons

Goals: The goal is to learn more about how I can best support the patient and encourage her to keep up with her treatment plan for best results.

Citation:

["Patient Engagement Strategies & Examples to Boost Outcomes." Accessed: Feb. 09, 2026. [Online]. Available:
1 <https://www.insidercx.com/blog/patient-engagement-strategies>
]

Content:

- Main factors that affect patient engagement
 - Patient characteristics
 - Demographics: age, gender, socioeconomic status
 - personal beliefs
 - mental and emotional state
 - Healthcare professionals
 - knowledge, expertise, communication skills, attitudes, and professional behavior
 - positive interactions, empathy, and respect
 - Healthcare system
 - accessibility and availability of services
 - supportive policies and regulations
 - overall quality of care
 - organization
 - Environmental factors
 - physical and socioeconomic environment
 - safety and comfort of facilities
 - accessibility features
- 7 patient engagement strategies
 - 1. Improve communication with patients
 - ensure patients clearly understand health conditions and treatment plans
 - use language that patient can easily understand
 - be available for questions
 - communicate effectively and empathetically
 - 2. Personalize patient care as much as possible
 - each patient is unique with own set of needs, preferences, and circumstances
 - go beyond standard treatment plan and take personal health goals, lifestyle choices, and individual concerns into account
 - accommodate patient's schedule
 - 3. Improve accessibility to care and medical information
 - physical access to healthcare facilities, patient medical records, and ability to communicate with providers
 - offer Telehealth services
 - user-friendly patient portals
 - 4. Improve health literacy of patients
 - ability to understand information and make informed decisions about care
 - helps patients accurately describe issues

- create educational materials easy to read and understand
 - simple language and visuals
- workshops and seminars to educate
- teach-back method
- online resources
- 5. Use feedback to improve patient experience and care quality
 - implement patient feedback system
 - surveys
 - regularly review and analyze feedback data to identify common themes and areas for improvement
 - patient advisory councils
- 6. Encourage shared decision making
 - patient and healthcare providers work together to make patient care decisions
 - collaborative approach
- 7. Strengthen social support
 - family and caregiver involvement
 - support groups
 - community resources
 - peer mentoring programs

Conclusion/Action Items:

Not all of these strategies are completely relevant to our patient, Maggie, however they are still informative. Many of these are explained in a hospital/clinical setting, whereas our work is very much out-patient focused. However, I think that encouraging Maggie to be more involved with communication is more important than communication with Debbie. This is because it can become almost like a game of telephone, which is not productive for any parties involved. If the team could know more about Maggie's schedule, then we could coordinate a meeting with both her and Debbie to get primary opinions. Additionally, we need to find a way to ensure that Maggie understands just how necessary it is for her to wear the AFO. If she continues to not wear it, then her condition will progress at a faster rate. Finally, if she doesn't wear it, then we cannot fully customize it to her liking.



03/16/26 Brainstorming Notes: Collaboration Between Two Academia Institutions

AVERY LYONS - Mar 16, 2026, 7:26 PM CDT

Title: Brainstorming Ethics Behind Collaboration with 2 Universities

Date: 3/16/2026

Content by: Avery Lyons

Goals: The goal is to brainstorm important things to keep in mind in terms of ethics when working with 2 universities.

Content:

- Main concerns
 - Establishing clear goals
 - Publishing vs. patenting
 - Purpose is to help a real-world patient, not to directly benefit either university
 - Credit
 - The University of Wisconsin-Madison owns the project due to its continuous funding over the last 4 semesters, but the University of Michigan will obviously get credit where it is due
 - Copyright
 - Intellectual Property
 - Data
 - Ensure the data is recorded in a consistent manner
 - Ensure the data is stored in a safe place in accordance with HIPAA
 - Communication
 - Ensure testing protocols are precise with no confusion
 - Be available for questions in the case that there is confusion
 - Find a testing date(s) that works for all 3 parties
 - UofM, UW, and the client & patient
 - Schedule at least one meeting to communicate expectations and timelines
 - Contract?
 - Professional behavior
 - Patient safety
 - Adequate testing supervision
 - Ideally a professor or graduate student that is well-versed in force plate testing
 - HIPAA
 - confidentiality and privacy is kept
 - no one that is not affiliated with the project should be in the testing space
 - No emailing photos of the patient's face or identifiable patient data

Conclusion/Action Items:

I could not find an exact research source that discussed the ethics behind two universities collaborating together, so I decided to make my own list of ethical factors that may be involved should our team at the University of Wisconsin-Madison collaborate with the University of Michigan.



03/16/26 Research Notes: Final Product Finishes

AVERY LYONS - Mar 16, 2026, 7:03 PM CDT

Title: Research: Final Finishes

Content by: Avery Lyons

Goals: The goal is to research the best ways to improve our prototype to look like a final, finished product.

Citation:

“CastCoverz! Cast Covers, Crutches & Accessories, Waterproof Products.” Accessed: Mar. 16, 2026. [Online]. Available: <https://castcoverz.com/>

“3 Easy Ways to Stop Fabric from Fraying,” wikiHow. Accessed: Mar. 16, 2026. [Online]. Available: <https://www.wikihow.com/Stop-Fabric-from-Fraying>

Content:

- CastCoverz!
 - May help keep the AFO clean
 - Help change up the look
 - All black may help blend into dark pants
 - Patterned covers may counteract inconspicuous idea
- 3D printing the CF-PLA in a matte finish
 - Is this possible with Makerspace 3D printers?
- Limit fraying of straps
 - Heat sealing
 - Use lighter or candle to heat the polyester edges until they lightly melt
 - Move the strap back and forth in the flame quickly to form a sealed, plastic-like edge
 - Liquid sealants
 - Fabric glue, seam sealant (Fray Check)
 - Sewing
 - Fold edges over and sew a hem
 - Sew a zigzag stitch using a machine directly over raw edge
 - Sew a whipstitch
 - Cutting
 - Use sharper scissors or a hot knife

Conclusion/Action Items:

CastCoverz! may not be the best fit for our patient, as many of their covers are patterned. Additionally, the AFO is already all black, so a black cast cover is irrelevant. For getting rid of/preventing frayed edges, heat sealing and/or liquid sealants may be our best option. The only worry with a liquid sealant would be leaving behind residue, which could again detract from the aesthetically pleasing portion of our design.



Training Documentation 2

AVERY LYONS - Mar 29, 2026, 5:36 PM CDT



This certifies that Avery Lyons has completed training for the following course(s):

Course	Assignment	Completion	Expiration
Biosafety 102: Bloodborne Pathogens for Laboratory and Research	Biosafety 102: Bloodborne Pathogens Safety in Research Quiz 2026	3/13/2026	3/13/2027
Biosafety Required Training	Biosafety Required Training Quiz 2024	3/3/2025	3/3/2030
Chemical Safety: The OSHA Lab Standard	Final Quiz	3/3/2025	
UW Human Subjects Protections Course	Basic/Refresher Course - Human Subjects Research	10/25/2025	10/25/2028

Data Last Imported: 03/29/2026 04:24 PM



01/28/26 Lecture 2 Notes: "Library Session 1: Article searching, source evaluation, and citation management"

AVERY LYONS - Jan 28, 2026, 1:52 PM CST

Title: Lecture: "Library Session 1: Article searching, source evaluation, and citation management"

Date: 1/28/2026

Content by: Avery Lyons

Goals: The goal is to explore the library resources available.

Content:

- How tech works
 - Online Search Engines (ex. Google)
 - Index info gathered from the internet by crawlers; they do not directly include informational content
 - Produce a results list based on your input
 - LLM Chatbots (ex. ChatGPT)
 - Trained on internet data
 - Produce text based on your input
 - Predictive text generators, not search engines
 - not always correct
 - trained on undisclosed data
 - Databases (ex. Scopus, PubMed)
 - Directly include and index info sources or records about sources
 - Produce a results list based on your input
- Evaluating your sources
 - Relevance: What is this source about?
 - Authority: Who created this?
 - Quality: Why was this written and how does that affect the information?
 - Currency: When was this source created?
- Technical Reports
 - publish the results of scientific or technical research, often using federal funds
 - research is performed and reports are produced by companies, universities, and government laboratories
 - Recommended databases include: DTIC, NTRL, OSTI
- UW Library Tips
 - Use the FindIt button to request a copy of articles that do not yet allow full access
 - Receive email with link to full text
 - Use the Ask a Librarian box for immediate support from real librarians
 - can use until about 10 PM

Conclusions/action items:

The FindIt button when utilizing UW-Madison library databases is definitely new and useful information to me. I am excited to try it out for my primary source research if I choose to use Scopus. Additionally, I did not know that there was real librarian support pretty much all day. I will be using the Ask a Librarian button if I ever need help. It's great to know that this is a resource! Also, as someone who spent the previous summer working at the NSCEB in Washington D.C., I am excited to learn that I have hands-on experience with technical reports. The NSCEB was created for the sole purpose of publishing their report. While I joined the team after the report was already published, I did help with outreach and awareness afterwards.



02/04/26 Lecture 3 Notes: "Resume, Cover Letter, and Job Postings"

AVERY LYONS - Feb 04, 2026, 1:54 PM CST

Title: Lecture: "Resume and Cover Letters"

Date: 2/04/2026

Content by: Avery Lyons

Goals: The goal is to get feedback on my cover letter and resume from my peers to make a final draft.

Content:

- The Job Ready Essentials
 - Internship/Co-op pipeline
 - professional branding
 - interviewing and pitching
- Project Leadership and Ethics
 - Project Management
 - Engineering Ethics
 - Critical Decision Making
- Technical and Advanced Pathways
 - Hands on experience, 3D printing, CAD
 - Medical school, law school, grad school
- Peer Review Instructions
 - complete rubric for 2 people
 - be professional
 - offer helpful comments
 - 1 positive
 - 1 area of improvement
 - 1 area to be expanded

Conclusions/action items:

I reviewed Xicheng and Sydney's resume and cover letters. I received some great feedback. First, I am going to sync up the order of the jobs that I talk about in my resume and cover letter. I will also try to eliminate some of the white space in my resume to make it more concise.



02/11/26 Lecture 4 Notes: Presentation Tips

AVERY LYONS - Feb 11, 2026, 1:40 PM CST

Title: Lecture 4 Notes: Presentation Tips

Date: 2/11/2026

Content by: Avery Lyons

Goals: The goal is to get some presentation tips and practice interviewing.

Content:

- Layout and Contents
 - Bullets
 - never have a single hanging bullet
 - top left bullet should line up across slides
 - Fonts
 - be consistent with style
 - legible
 - Organization- use a logical flow
 - not always chronological
 - design ideas should be presented in same order in all places
 - Use your content- don't use pictures that you won't discuss
 - 6x6 rule of thumb
- Keep audience interested
 - So what?
 - Use your project's impact to stimulate interests
 - Attitude: don't talk down to your audience
 - Presence: It's your topic- be excited
 - Mannerisms: Talk to your audience
 - Highlights vs. Depth
 - cannot possibly cover everything that you've done
 - hit the highlights of design matrix
- Figure captions
 - For images: Figure X, what it's showing/highlighting
 - citation if not your own
 - For graphs: Figure X, data present
 - For comparison plots: Figure X, show key result
- Graphics: CAD
 - one or two clear images
 - labels and scale REQUIRED
 - never use drawings in presentations or reports
- Graphics: sketches
 - Remove background
 - Clean lines
 - labels and scale required
- Results
 - never show raw data
 - appropriate font sizes
 - show statistical analysis
- Effective storytelling for figures
- Interview Guidelines
 - Bring a small portfolio

- Be specific/personal
 - Undergraduate research/independent study
 - Design projects/leadership

Conclusions/action items:

I will implement the presentation tips to ensure that our group does everything correctly with minimal mistakes.

AVERY LYONS - Feb 11, 2026, 2:07 PM CST

BME 301 - Job Interviewing

Job Interviewing

Prior to class

Read the guidance provided by ECS: <https://ecs.wisc.edu/academics/centerforhr/> (including the ECS Job Search Guide - INTERVIEWING pdf found at the link above. (You do not have to class prepare to fully for this activity.)

Read/like the interview questions provided below and prepare for a conversation with your peers based on the in-class activity.

During class

1. Form groups of 3. You will each pick 3 questions off of the list of example interview questions below. Each person must pick different questions within your group.
2. Type up your answers to your chosen questions (you make a copy of the gDoc and type your responses below).
3. Take turns sharing your answers with your group members (start with one of the questions each, then keep taking turns until everyone has shared a 3). After taking to your group members answers, note what you liked about their responses, and add to their response (both verbally and in your notes) if you have suggestions.
4. Each answer should be no more than 1-2 minutes in length.
5. Each post-answer discussion should be no more than 2 minutes in length.

Interview questions

While engineering academics will often ask you a number of technical questions to ensure you have the skills that they need, they will often choose a set of behavioral questions to determine what kind of employee you might be and how you handle non-technical situations. Familiarize yourself with these sorts of questions so that you are not surprised by them in an interview.

1. Talk about a weakness or challenge you've had to overcome in your life.
2. Consider your most recent engineering job or academic engineering project (or one thing that you've learned recently from that job experience).
3. Talk about a serious mistake or a time when you failed at something pretty important, and explain how you resolved it or dealt with it.
4. Talk about a time in your life when you had to move to live in a different area; what were the big challenges about the move, what made you most uncomfortable, and what strategies did you develop to become more comfortable? How did you deal with the change?
 - a. In Summer 2025, I moved to Washington, D.C. for an internship. The biggest challenges associated with the move were not only finding an apartment, but also navigating my way around the city and getting to

Adapted with permission from InterGGR 2017

1

[Download](#)

Copy_of_BME_301_-_Job_interview_activity.pdf (111 kB)



02/18/26 Lecture 5 Notes: Presentation Peer Review

AVERY LYONS - Feb 18, 2026, 1:52 PM CST

Title: Lecture 5 Notes: Preliminary Presentation Peer Review

Date: 2/18/2026

Content by: Avery Lyons

Goals: The goal is to get some presentation tips and practice interviewing.

Content:

- Reviewed slides for the Pavlick Harness Sensor
 - Comments:
 - Be more specific about patient demographic (e.g. age)
 - Explain designs in simple terms with less acronyms when presenting
 - Include small images of competing designs so the audience knows what to compare
 - Some small formatting errors
- Reviewed feedback for our presentation
 - deleted my section of key concepts for the design matrix
 - will explain during presentation

Conclusions/action items:

I will implement the presentation feedback to ensure that my slides for the presentation are as smooth as possible.



02/25/26 Lecture 6 Notes: Diversity and Inclusion in Design

AVERY LYONS - Feb 25, 2026, 1:56 PM CST

Title: Lecture 6 Notes: Diversity and Inclusion in Design

Date: 2/25/2026

Content by: Avery Lyons

Goals: The goal is to learn how I can be more inclusive in my designs.

Content:

- What does diversity mean in engineering design?
 - creating designs for a multitude of demographics (i.e. various heights, various sizes)
 - creating affordable designs to ensure accessibility
 - designs that take cultural and religious beliefs into account
 - keeping an open mind
 - ethnicity
 - skill sets
 - experiences
- What does universal design mean?
 - creating multiple versions to cater to everyone
 - taking many factors into account (i.e. age, capability)
 - using many languages to ensure no exclusion of those that are blind, etc.
 - user friendly
 - no need for specialization- usable by all people, not just the average user
- 7 Principles of Design
 - 1. Equitable Use
 - Design is useful and marketable to people with diverse abilities
 - 2. Flexibility in Use
 - Design accommodates a wide range of individual preferences and abilities
 - 3. Simple and Intuitive Use
 - Use of design is easy to understand, regardless of user's experience level, knowledge, language skills, or current concentration level
 - Eliminate unnecessary complexity
 - Provide effective feedback
 - 4. Perceptible Information
 - Design communicates necessary information effectively to user, regardless of ambient conditions or the user's sensory abilities
 - 5. Tolerance for Error
 - Design minimizes hazards and the adverse consequences of accidental or unintended actions
 - 6. Low physical effort
 - Design can be used efficiently and comfortably and within a minimum of fatigue
 - 7. Size and space for approach and use
 - Appropriate size and space is provided for approach, reach, manipulation, and use regardless of user's size, posture, etc.
- How does this relate to Ethics?
 - Not cheaping out or cutting corners to save money
 - Not giving the design to the public until all safety concerns have been addressed
 - Not deliberately cutting out certain groups that the design could exclude

Conclusions/action items:

We are addressing the Simple and Intuitive Use design principle. We have brainstormed coming up with an instruction manual to make our design easier to use.



03/04/26 Lecture 7 Notes: Library Session 2- Patents Standards, and Other Design Resources

AVERY LYONS - Mar 04, 2026, 2:04 PM CST

Title: Lecture 7 Notes: Library Session 2- Patents Standards, and Other Design Resources

Date: 3/04/2026

Content by: Avery Lyons

Goals: The goal is to learn more about library resources.

Content:

- Standards
 - Libraries have:
 - ASTM
 - ASABE
 - IEEE
 - Freely available online:
 - ASSIST quick search, EverySpec, FDA, International Telecommunications Union, NASA, NFPA
 - All other cases:
 - check TechStreet Enterprise for titles and use the 'Request a Standard' form
- Market/Industry Sources
 - Find info on companies, industries, consumer trends with business databases
 - Library search guides to help you get started
 - Specific recommendations:
 - Data Axle Reference Solutions
 - directory info on businesses and lifestyle info on consumers
 - IBISWorld Industry Reports
 - market research reports on over 700 U.S. industries
 - ProQuest One Business
 - full text business journals, newspapers, dissertations, and industry reports
- Patents and Prior Art- Searching
 - Patent examiners evaluate applications against prior art, includes:
 - Inventions disclosed to U.S. and Foreign Patents and Patent Applications
 - Inventions disclosed in publications
 - Inventions currently for sale or in public use
 - Hypothetical
 - we have an idea for a bouncing squirrel feeder that keeps away from bird feeders
 - We know of a similar device, The Squngee, which helpfully includes a patent number on its packaging: US 6,474,260
 - Go to [Lens.org](https://www.patentlens.org) and find the patent for The Squngee
 - Ways to expand search: check citations, rearrange words
 - Patent examiners evaluate for:
 - Usefulness
 - Novelty
 - Non-obviousness
 - Claims
 - Define legally enforceable aspects of patent
 - Every utility patent has at least one claim
 - Each claim is a single sentence
 - Preamble
 - Transition
 - Antecedent Basis
 - Independent Claims

- Standalone
- Contain all limitations necessary to define an invention
- Dependent Claims
 - Must refer to previous claim
 - Must further limit the claim
 - Includes all limitations of claim it refers to

Conclusions/action items:

[Lens.org](https://www.lens.org) is a very helpful website when it comes to patent research. The market/industry sources will come in handy when it comes time to write the Executive Summary for our project as we will need to complete market analysis.



03/09/26 Tong Lecture Notes

AVERY LYONS - Mar 09, 2026, 12:20 PM CDT

Title: Tong Lecture Notes

Date: 3/09/2026

Content by: Avery Lyons

Goals: The goal is to learn more about Dr. Justin Williams' work.

Content:

- Peter Tong (1941-2025)
 - founded Inaugural Peter Tong Department Chair
 - came to every design presentation
- Neurotechnology
 - science fiction vs. reality
 - Avatar, The Six Million Dollar Man, Star Wars
- Growing up
 - rural South Dakota with population of 91
 - family farm
 - not many people went to college
 - liked to fix things on the farm --> mechanical engineering
 - went to work for Daktronics (makes scoreboards)
 - friend died pole vaulting --> wanted to learn more about the brain
 - went to ASU for BME
 - postdoc at U of Michigan
 - starting driving between Ann Arbor and Madison to work with doctor at UW
- 2003: BRL --> failed
- Gore bought NIT
- Neuronexus --> Greatbatch --> NEL/Neuronexus
- NeuroOne
 - Sometimes less is more
 - spent every Tuesday and Thursday in OR
 - Epilepsy surgery
 - thin film electrodes
 - Nasdaq
- Brainsync
 - Market and timing is everything
 - UW Hospital Brain Computer Interface Project
 - Can you do this without an implant?
 - Use cap with electrodes outside
 - Tweeting by thinking
 - Stroke rehabilitation
- NeuraWorx
 - sometimes its personal
 - PSP is a rare disease
 - buildup of tau protein damaging brain cells
 - newly discovered glymphatic system
- Now working on headband simulator

Conclusions/action items:

I missed the Tong lecture due to an internship call. After watching the recording, I have learned many lessons from Dr. Williams: know your market, timing is crucial, be motivated, work with good people, and it's okay to make it personal.



03/11/26 Lecture 8 Notes: Protocol Development

AVERY LYONS - Mar 11, 2026, 1:46 PM CDT

Title: Lecture 8 Notes: Protocol Development

Date: 3/11/2026

Content by: Avery Lyons

Goals: The goal is to begin writing testing protocols.

Content:

- Fall fast and fail forward
 - Perfection is not important
 - Low fidelity - cardboard, etc.
 - Start early!
 - Test individual pieces
 - Documentation still required!
 - Check out the 1080 ECB closet
- Preliminary testing/Analysis
 - Low fidelity prototyping
 - Circuit diagrams and circuit testing
 - Fittings (connection points)
 - FBDs
 - Mechanics of materials
- Planning general concepts for fab and testing
 - Materials - detailed list = match material expense table + more
 - Name of the material
 - Concentration, amount, or starting dimensions
 - Manufacturer and part number
 - Purpose of material
 - List of equipment needed (manufacturer and model number if known)
 - Include references to papers or research in other parts of notebook
 - Methods - step by step plan - list
 - Mix - for how long and with what vigor, etc.
 - Cut - with what tool and what size, etc.
 - Rule #1: repeatable by unfamiliar reader
- 3D printing
 - Same rules apply - plus more
 - Materials
 - Manufacturer and model of the printer
- Manufacturing
 - Consider throughout the process
 - Cannot manufacture everything you can 3D print
 - Common methods
 - Molding - blow, injection, thermoforming, extrusion, and rotational
 - Machining / subtractive manufacturing - mill, lathe, waterjet
 - Joining - welding, soldering, screwing, riveting, and adhesives
- Seek professional advice
 - Design Innovation Labs
 - Design hub / design consultation
 - Makerspace / ECB shop
 - Use experts in the field - faculty
- Fabrication Plans - template

- Team name
- Team members
- Project title
- Timeline (Gantt chart)
- Materials and costs table
- Fabrication Details
 - 1. Name of fabrication step/ portion of prototype
- Testing plan - additional considerations
 - Think about statistics before you start
 - What controls are needed?
 - Do you have to design something to ensure precision and accuracy?
 - Test fixture for MTS
 - Apparatus to hold items in fixed position for motion capture, etc.
 - Code to perform analysis
 - Reference and discuss the PDS criterion being tested
 - Testing plan should match fabrication plan
 - Each component must be tested

Conclusions/action items:

We will take these tips and requirements into consideration for our testing plans and fabrication plan.



03/18/26 Lecture 9 Notes: Brevity in Communication

AVERY LYONS - Mar 18, 2026, 1:47 PM CDT

Title: Lecture 9 Notes: Brevity in Communication

Date: 3/18/2026

Content by: Avery Lyons

Goals: The goal is to begin writing testing protocols.

Content:

- Purpose of elevator pitches
 - Succinctly and effectively communicate your ideas
 - Seize opportunities
 - Use an 'elevator ride' to pitch = short
 - Goal
 - Capture attention
- Crafting your pitch
 - Know your audience: Tailor your pitch to the interests and needs of the audience
 - Practice: Rehearse your pitch until it flows naturally and confidently
 - Be authentic: Let your passion and enthusiasm shine through
 - Keep it simple: Avoid jargon and technical language that may confuse audience
 - Adapt and iterate: Be open to feedback
- General structure
 - Introduction: We are on project X... (be concise)
 - Attention grabber: I'm looking for help with...
 - Value proposition: clearly articulate what you offer:
 - Target customer
 - Benefits: highlight key aspects
 - Call to action: We are struggling with X... What are your suggestions?
- General structure- Tong Awards
 - Introduction: We are on project X... (be concise)
 - Attention grabber: We have developed a device to do X
 - Value proposition: Currently there is not a device to do X as existing technologies and patients fail because of Y
 - Benefits: It is estimated that X people would benefit from this device which has a potential market of \$. Demonstrate prototype fully.
 - Call to action: Do you have any questions?
- Dos and don'ts of elevator pitching
 - Do
 - Maintain eye contact and exude confidence
 - Keep it concise and focused
 - Tailor your pitch to different audiences
 - Don't
 - Overwhelm with unnecessary details
 - Forget to listen and engage with your audience
 - Sound rehearsed or robotic
- Purpose of Executive summary
 - Essentially an elevator pitch put into a 1-page document
 - Provides a concise overview of a longer document
 - Captures attention and conveys key information
 - No citations
- Purpose of abstract
 - Provides a clear, concise, and specific summary of your work

- Helps readers decide if they want to read the full paper
- Journals may require a longer executive summary style abstract
- Roughly 250 words most of the time
- General structure of abstract
 - Background/context
 - Objective
 - Methods
 - Results and Analysis
 - Discussion/Conclusion
- Technical Reports
 - Eliminate extraneous text
 - Do not explain the obvious
 - Only provide details required to reproduce final design/testing
 - Avoid conversational text
 - Spell out acronyms once when first introduced
 - Do not include raw data
 - Proofread thoroughly

Conclusions/action items:

We will begin working on our Executive Summary.



03/25/26 Lecture 10 Notes: Ethics in Engineering

AVERY LYONS - Mar 25, 2026, 2:07 PM CDT

Title: Lecture 10 Notes: Ethics in Engineering

Date: 3/25/2026

Content by: Avery Lyons

Goals: The goal is to understand more about applying ethics to engineering.

Content:

- How do you define ethics?
 - Ethics are developed through your personal beliefs and experiences
 - Is there a difference between personal and professional ethics?
 - Yes, be careful what you say in the workplace
 - What might be okay to say in front of friends may not be appropriate for coworkers
- Ethical Problem Solving
 - Establish a Need (site visit)
 - Understand the problem
 - Generate solutions (brainstorming)
 - Evaluate solutions
 - Develop detailed design
- Ethical Decision-Making Process
 - Awareness: understand that you are facing an ethical dilemma
 - Stakeholders: imagine their needs, put yourself in their position
 - Options
 - Analysis of Options
 - Harm test
 - Publicity test: Would you want your decision published online?
 - Reversibility test: How would you feel if you or someone you loved was adversely affected by this?
 - Universality test
 - Respect for persons test: Does this decision best respect the rights and dignity of others?
 - Utilitarian test
 - Social justice test
- Entry:
 - What components of your design have ethical dimensions?
 - Our patient is a minor. We have to obey HIPAA as well as keep her parents informed about project status, communication, and any other factors that affect the patient.
 - How will your team address the ethical dimensions?
 - Our first line of contact is the patient's mother. We have only used the patient's personal phone number under the permission of the parent.

Conclusions/action items:

We will begin working on our Executive Summary.



04/08/26 Lecture 11 Notes: Engineering Judgement

EVERY LYONS - Apr 08, 2026, 2:09 PM CDT

Title: Lecture 11 Notes: Engineering Judgement

Content by: Avery Lyons

Goals: The goal is to understand more about applying judgement to engineering.

Content:

- What is engineering judgement?
 - The process of making informed decisions, often in situations where there isn't a clear-cut answer or specific code or standard to follow, by weighing available information, experience, and principals to live by
- ABET Outcome 6:
 - an ability to develop and conduct approximate experimentation, analyze and interpret data, and use engineering judgement to draw conclusions
- How do you learn engineering judgement?
 - real world problems, open-ended problems, critical thinking (evaluate solutions with testing and analysis), communication, intuition (use experiences and reflect on past projects), ask questions, handling uncertainty, teamwork and collaboration
- Credit: Desha Chadha, Imperial College London
 - Interviewed 20+ professional engineers from Europe, USA, and East Asia
 - Identified common terms/elements and created a 3D model: Attitudes, Behaviors, and Cognitive
 - Attitudes: what you feel and believe about a specific issue
 - Behaviors: how you demonstrate and act upon your knowledge while addressing a specific issue
 - Cognitive (internal and external): what you know about, and are able to do, to address a specific issue
- Comments
 - A7 may not be applicable due to the fact that you do not have to feel self-confident about every decision. Confidence is developed over time.
 - B2 is very important because asking questions is a great way to learn. Your teammates and other contributors may have more/different experience than you and may be able to offer a unique perspective.
 - B3 is very important because failure is also a great way to learn. How would you know the outcome if you never try?
 - A5 is unclear due to the word "comfortably". This is a broad and vague word that may mean different things to different people.

Conclusions/action items:

I have previously used engineering judgement in projects, internships, and classes. However, I do not think that I used it consciencely. I will work on actively using this judgement. The team will use engineering judgement for our current project and our projects in the future.



04/15/26 Lecture 12 Notes: Poster Presentations

AVERY LYONS - Apr 15, 2026, 1:46 PM CDT

Title: Lecture 12 Notes: Poster Presentations

Content by: Avery Lyons

Goals: The goal is to get tips on making the best poster possible.

Content:

- Before you start
 - Where will you print?
 - Libraries: College or Steenbock
 - Print shops
 - How to print?
 - Ask what size
 - Can printers cut off excess white space?
 - File type
 - What makes a good poster?
 - No hanging bullets
 - No blurry pictures
 - No CAD drawings, use actual sketch
 - Font big enough to read
 - Figure captions
 - No typos
 - Logical flow (Results shouldn't be first and intro shouldn't be last)
 - No raw data
 - Use color and visuals, but not too overwhelming
- Getting Started
 - Read the requirements and evaluation form
 - Include relevant and correct contact information
 - Names, emails, websites, affiliations
 - Descriptive
 - Show your BEST results
 - Minimize text (bulleted w/ descriptive subtitles)
 - Lots of colorful but high resolution pictures
 - Full captions with figure number, explanation, and citation
 - Font styles must be easy to read
 - Colors: use for ease of reading, to separate sections, and to highlight important points
 - Don't put red and green together in case of color blindness
- Formatting
 - Must be able to read text from 3 feet away
 - Usually 24-28
 - References in relatively small font
 - Reference pictures and graphics that are not your own
- Context of Use and Workflow
 - Start with user and setting (who, where)
 - Show workflow (before -> during -> after, and/or inputs -> outputs)
 - Include user-device interaction
 - Place in larger system (app, clinic, decision)
 - Use color/grouping to organize/show what belongs together
 - Use labels with minimal text
- Flow Charts
 - Clear steps with obvious flow

- Start with context: user/patient- not just device
- Show the system: inputs -> outputs -> outcome
- Final Details
 - Handouts - especially at conferences
 - Business cards
 - Copies of poster
 - Surveys
 - Have several other people proofread
 - General feedback on appearance and context
 - Is it understandable by an unfamiliar audience?

Conclusions/action items:

We will each bring an individual copy of our poster for peer review. Our goal is to have the poster done by Friday to send to Sam for feedback.



04/22/26 Lecture 13 Notes: Final Poster Feedback

AVERY LYONS - Apr 25, 2026, 8:14 AM CDT

Title: Lecture 13 Notes: Final Poster Feedback

Content by: Avery Lyons

Goals: The goal is to get tips on how to improve our final poster.

Content:

- Review poster of another team
- Get feedback on our poster

Conclusions/action items:

We gave feedback and received feedback on our poster. The biggest takeaway was making sure that we described the actual testing that took place, not just the results.



03/10/26 Fabrication Notes

AVERY LYONS - Mar 11, 2026, 3:08 PM CDT

Title: Fabrication Notes

Content by: Avery Lyons

Goals: The goal is to document the fabrication of this semester's prototype.

Content:

- Mediolateral sides
 - 3D printed using Kalob's updated designs with the sides being elongated
 - 3D printed out of 50% infill CF-PLA
- Back straps
 - Cut out of ballistic nylon
 - Threaded through the mediolateral sides by Alex and myself
- Doubled padding
 - Sierra and I cut the padding out of mesh using scissors by tracing the printed mediolateral sides
 - Alex attempted to sew the two layers of padding together on the sewing machines, but encountered difficulties
 - Alex hand sewed the medial side of the padding and I hand sewed the lateral side of the padding
 - Sewed the edges together
 - Alex then super-glued the padding to their respective sides
 - Kalob cut the holes in the padding for the straps using an exacto-knife
- Straps
 - The dorsiflexion strap and toe strap still needs to be fabricated
 - Kalob used a sewing machine to sew the back straps using the Fall 2025 model for reference

Conclusion/Action Items:

We will fabricate the dorsiflexion and toe straps, most likely tomorrow. We will then attach these and get the prototype ready to ship to the client for testing. We will keep corresponding with the University of Michigan to set up concrete testing plans.



03/10/26 Protocol Notes

AVERY LYONS - Mar 11, 2026, 3:16 PM CDT

Title: Protocol Brainstorming Notes

Content by: Avery Lyons

Goals: The goal is to brainstorm what factors need to be taken into account when writing the protocol.

Content:

- Testing goals
 - Test both the final design of Fall 2025 and the updated Spring 2026 design and compare results
- Specifics:
 - Ideally want yellow Adidas to be worn again (these were worn in previous testing)
 - Both shoes worn during shoe tests
 - For stabilogram testing, 30 seconds of standing on one foot is ideal
 - If she comes down for a second/loses her balance, we will not stop the test
 - How will this affect the data?
 - For force plate testing, want her to walk at least three steps
 - Does it matter what foot she starts with?
 - Length of U of M's force plate shouldn't matter: the more steps, the better
 - Does calibration matter?
 - Are there any force plate settings we need to take into account?
 - Comfortability survey again
 - Any pressure points? Rubbing?

Conclusion/Action Items:

We will meet as a team on Monday to discuss the official protocols and finalize our testing plans. We need to be as specific as possible as we will not be the one's conducting the actual testing.



03/10/26 Preliminary Report Personal Feedback Notes

AVERY LYONS - Mar 11, 2026, 3:30 PM CDT

Title: Preliminary Report Personal Feedback Notes

Content by: Avery Lyons

Goals: The goal is to take notes on what I can improve on my sections for the preliminary report.

Content:

- Missing
 - Figure with dimensions for current design
 - Add labels for references when explaining parts of design
 - Add numerical values for Flexibility section of Dorsiflexion design matrix
 - Additional paragraph about why the chosen materials won and justifications
- Fix
 - Order of headings and design matrices
 - Wording from past semesters in Dorsiflexion Support explanation under Dorsiflexion design matrix
 - Sentence structure of Comfort section of Dorsiflexion design matrix
- Add Info
 - Reason for 50% infill of CF in CF-PLA
 - Why ballistic nylon was given same score in Durability section of Dorsiflexion design matrix but not chosen over elastic polyester
 - Why TPU was chosen for Discreteness section of Dorsiflexion design matrix when all materials scored the same
 - Compressive and torsional stress values for Strength section of Inversion/Eversion design matrix

Conclusion/Action Items:

I will make these changes when it comes time to write the final report.



03/16/26 Fabrication Protocol Notes

AVERY LYONS - Mar 16, 2026, 7:34 PM CDT

Title: Fabrication Protocol Notes

Content by: Avery Lyons

Goals: The goal is to document my portion of the fabrication protocol.

Content:

- Front strap fabrication documentation
 - Necessary materials
 - 1" x 12" strip of ballistic nylon
 - 1" x 2" piece of velcro
 - Fabric scissors
 - Super glue
 - Sewing kit/Sewing machine
 - Completed body of brace fitted onto mold of foot
 - Steps
 - Cut strip out of ballistic nylon
 - Cut strip of velcro
 - Front strap secured on lateral side via sewing
 - Front strap looped through medial side and brought back to lateral side
 - Velcro is attached to lateral side to allow adjustability
 - Superglue velcro adhesive to increase support
- Labeled and dimensioned images to enhance understanding



Conclusion/Action Items:

We have decided to hold off on turning in the testing protocol until we know if the collaboration with the University of Michigan is happening. If it is not, we will need to write new protocols for the client to use OpenCap for at home testing.



03/25/26 Brainstorming Executive Summary

AVERY LYONS - Mar 25, 2026, 12:20 PM CDT

Title: Executive Summary Ideas

Content by: Avery Lyons

Goals: The goal is to brainstorm for the executive summary for the BME Design Excellence Award.

Content:

This award is focused on critical-path research or specialized one-of-a kind devices. It does not require the team to perform market analysis, but instead should highlight how thoroughly the engineered solution addresses the client's problem through rigorous design, construction, testing and validation. Criteria for assessment are:

How well did the team:

- Characterize the fundamental problem.
 - 16 year old with FSHD
 - thinks current AFO designs on the market are too noticeable/bulky
- Identify and review any competing devices and/or existing intellectual property
 - Fall 2024, Spring 2025, and Fall 2025 designs
 - Passive-dynamic AFO
 - Jointed AFO
 - Supermaleolar orthosis
- Briefly describe the design process.
 - 3D print the sides
 - Cut all 4 straps (2x back, 1x front, and dorsiflexion) from ballistic nylon and elastic polyester
 - cut out mesh padding and sew two layers together
 - super glue padding to the sides
 - cut slits for the straps
- Describe the resulting design and prototype
 - medial and lateral sides made of 3D-printed 50% infill CF-PLA
 - 2 back straps made of ballistic nylon
 - 1 adjustable front strap made of ballistic nylon
 - 1 dorsiflexion strap made of elastic polyester
 - 2 layers of padding on the mediolateral sides
- Succinctly describe the design validation process and the completeness of this testing.
 - Spring 2025: OpenCap
 - Fall 2025: force plate testing, no statistical significance, client reported noticeable improvement in gait
 - Spring 2026: OpenCap, hoping for statistical difference
- Summarize how well the design meets the problem and operational requirements.
 - Client reported comfort and satisfaction
 - Discrete, athletic look
 - Fits in a shoe
- Describe the impact of the design with respect to the user
 - Encourages the user to wear the brace more
 - Improves foot drop

o

Conclusion/Action Items:

When our patent was denied last semester, we were informed by WARF that there was not really a market for AFOs, especially those that are so thoroughly customized. This is why we have decided to submit for the BME Design Excellence Award rather than the Tong BME Design Awards.



04/08/26 Executive Summary Draft Feedback Notes

EVERY LYONS - Apr 08, 2026, 1:11 PM CDT

Title: Executive Summary Draft Feedback Notes

Content by: Avery Lyons

Goals: The goal is to take notes on what I can improve in the Executive Summary draft.

Content:

- Testing content
 - Update outline with what we have specifically done this semester for testing
 - MTS, Force plate, Motion capture, etc.
 - What has been improved based on testing
 - How does testing show success
- Formatting
 - Design improvements first then testing information

Conclusion/Action Items:

I will make these changes when it comes time to write the final draft.



04/15/26 Elevator Pitch Write-up

AVERY LYONS - Apr 25, 2026, 8:15 AM CDT

Title: Elevator Pitch Write-Up

Content by: Avery Lyons

Goals: The goal is to make an outline for the Elevator Pitch to ensure everyone hits and knows the key points.

Content:

- **Hook:** Walking shouldn't require thinking, but for many patients, every step is a challenge.
- **Who is the patient?**
 - 16-year-old girl with FSHD
 - Causes severe foot drop and mediolateral instability
 - Doesn't like the traditional AFOs available due to bulkiness and aesthetics
 - Located in Ann Arbor, MI
- **Previous models compared to current**
 - Version 1: Bungee cord design, no mediolateral support
 - Version 2: Mediolateral supports, no dorsiflexion support
 - Version 3: Hybrid of Versions 1 and 2de, but uses elastic strap instead of bungee cord
 - Version 4 (Current): Final semester, same design as Version 3 but updated
 - Updates:
 - Brought mediolateral supports down to the ground to increase stability
 - Shortened dorsiflexion strap to increase support
 - Sock accessory to further mitigate backward slippage
- **Current testing**
 - Collaboration with the University of Michigan Department of Kinesiology
- **Patient satisfaction**

Conclusion/Action Items:

I will update the patient satisfaction section when the patient responds to my request for her feedback. The client said she would make sure the patient responded by today, but I will send a follow-up email if I receive no response by tomorrow. Alex will fill out the testing section once she has looked through the data.



04/25/26 Final Report Work

AVERY LYONS - Apr 25, 2026, 8:23 AM CDT

Title: Final Report Work

Content by: Avery Lyons

Goals: The goal is to make an outline for my sections of the final report.

Content:

- Preliminary Materials
 - Explain the 3 dorsiflexion materials
 - Notable properties
 - Manufacturing
 - Sources
 - Explain the 3 mediolateral materials
 - Notable properties
 - Manufacturing
 - Sources
 - Add figure w/ labels so readers know what design features are being talked about
 - Add dimensions
- Design Matrices
 - Explain each category for the 2 matrices
 - Rewrite
 - Explain why each material won for that category
 - Sources
- Explain final material choices
 - Why PLA-CF was used despite pure CF winning
 - testing timelines
 - ease of fabrication
 - expenses
 - Why 50% infill?
 - Why elastic polyester ultimately won
- Ethics
 - HIPAA
 - Parental consent due to patient's age under 18
 - Professionalism
 - Keeping client and patient in loop via communication
 - Modes of communication
 - Keeping privacy when coordinating with University of Michigan
 - Ultimate use of AFO

Conclusion/Action Items:

I will use this outline to write my sections of the final report including preliminary materials, design matrices, final materials, and ethics. I will cite my sources as well as make adjustments based on feedback from the preliminary report.



1/28/26 Literature Search - Facioscapulohumeral Muscular Dystrophy

SIERRA LOOSEN - Jan 28, 2026, 3:36 PM CST

Title: Literature Search - Facioscapulohumeral Muscular Dystrophy

Date: 1/28/26

Content by: Sierra

Present: N/A

Goals: The goal is to learn more about FSHD which effects the user of our device

Link: <https://www.ncbi.nlm.nih.gov/books/NBK559028/>

Content:

- Facioscapulohumeral muscular dystrophy (FSHD) is a genetically acquired disease that leads to progressive muscle weakness
 - inherited in an autosomal dominant fashion
- It effects the skeletal muscle tissue of the individual
- Muscle groups involved include face muscles, muscles of the shoulder girdle, and lower extremity
 - FSHD starts proximally in the face and spreads distally to affected muscle groups
- There are two subtypes of FSHD
 - 95% of cases are type 1, in which the D4Z4 repeats become lost
 - 5% of cases are type 2, in which methylation and epigenetics are affected in a deletion-independent manner
 - Regardless of the type, the end result is the same
 - The DUX4 protein product that is normally only expressed in germline tissues becomes expressed in somatic cells (specifically myocytes which are the functional units of skeletal muscles)
 - DUX4 protein is especially toxic to myocytes which leads to cell death and muscle atrophy seen in FSHD patients
- FSHD is one of the most prevalent types of muscular dystrophy currently known
 - prevalence of approximately 3.2 to 4.6 cases per 100,000 people, does not seem to affect any racial group more or less than others
 - FSHD does seem to be less prevalent in women compared to men, with female patient's being diagnosed later in life than men
- The onset of physical exam findings in FSHD can occur across an individual's entire lifespan
 - most common during the second decade of life
 - development of symptoms typically occurs over a long period of time
- Genetic testing is the gold standard in diagnosing FSHD, but it can be aided by EMG, MRI, laboratory tests, and muscle biopsies
- There are currently no disease-modifying treatments for FSHD
 - Main treatment is supportive care and management of symptoms
 - physical therapy and rehabilitation exercises
 - Foot drop (which our user has) can be partially corrected with the use of ankle-foot-orthoses (AFOs)
- The overall lifespan of the patient is not affected, but roughly 20% of affected individuals will experience disability significant enough to required wheelchair use

Conclusions/action items:

Facioscapulohumeral Muscular Dystrophy is a genetic disease that leads to the degeneration of a person's skeletal muscles. FSHD currently has no cures, but treatments and rehab can help improve the patient's symptoms. The symptoms of this disease get worse over time, and right now our client would like us to focus on make an AFO to improve the drop foot and ankle inversion that the patient is experiencing. The team will continue building on previous semester's work to hopefully make a finalized product for the client and patient.



1/28/26 Literature Search - Ankle Foot Orthosis (AFO) stiffness design for mitigation of ankle inversion injury

SIERRA LOOSEN - Jan 28, 2026, 4:49 PM CST

Title: Ankle Foot Orthosis (AFO) stiffness design for mitigation of ankle inversion injury

Date: 1/28/26

Content by: Sierra

Present: N/A

Goals: Read a study about how AFOs can be used to prevent ankle inversion injuries

Link: <https://ieeexplore.ieee.org/document/8692490>

Content:

- The purpose of this study was to develop a simulation-based stiffness design for an AFO to reduce the risk of ankle inversion sprain during landing
 - the focus was on preventing subtalar inversion angles greater than 25 degrees (which are associated with injury)
- Ankle inversion injuries account for approximately 77% of lower limb ligament injuries
 - these injuries are common in sports and uneven terrain
- The traditional design of AFOs relies heavily on trial and error fabrication with poorly quantified mechanical properties
- Computational simulations of musculoskeletal tissue offers a way to optimize the AFO design without repeated patient testing
- This study used OpenSim to simulate 3D human movement with and without the AFO
 - the injury risk was evaluated using maximum subtalar angle during landing from free fall onto a 20 degree inclined plane
- Results showed that
 - increasing AFO translational stiffness generally reduced ankle inversion angle
 - the relationship between stiffness directions was nonlinear
 - multiple stiffness combinations successfully kept subtalar angles below 25 degrees
 - high stiffness in all three directions produced the lowest inversion angles (around 19 degrees)
- No single stiffness value is required as this study shows that there are multiple safe configurations
- the results support personalized AFO design, tailoring the directional stiffness to patient specific needs
 - some patient trials are still needed to verify the design, but the simulation based design reduces the dependence on repeated patient trials

Conclusions/action items:

Simulation based software can be used to aid with the prototyping and testing of AFOs. This is especially beneficial in our situation as the client and patient live in Michigan which makes it infeasible to do repetitive in person testing. The team will likely continue to use simulations to aid in prototyping and testing of this design as has been done in the previous work of this team.

SIERRA LOOSEN - Jan 28, 2026, 4:40 PM CST

Ankle Foot Orthosis (AFO) stiffness design for mitigation of ankle inversion injury

D. Talcott, J. Miller, M. S. Carroll, M.A.R. Lajo

Abstract— Modeling and simulation of human movement has the potential to improve the design of medical devices and rehabilitation devices by enabling the identification of cause-effect relationships in individual patients. One such application is the design of ankle foot orthosis (AFO) devices to mitigate the risk of ankle inversion injury during landing. This paper presents a simulation-based stiffness design for an ankle foot orthosis (AFO) that can help to mitigate the risk of ankle inversion injury during landing. The study was conducted using OpenSim to simulate 3D human movement with and without the AFO. The injury risk was evaluated using maximum subtalar angle during landing from free fall onto a 20 degree inclined plane. Results showed that increasing AFO translational stiffness generally reduced ankle inversion angle. The relationship between stiffness directions was nonlinear. Multiple stiffness combinations successfully kept subtalar angles below 25 degrees. High stiffness in all three directions produced the lowest inversion angles (around 19 degrees). No single stiffness value is required as this study shows that there are multiple safe configurations. The results support personalized AFO design, tailoring the directional stiffness to patient specific needs. Some patient trials are still needed to verify the design, but the simulation based design reduces the dependence on repeated patient trials.

1. INTRODUCTION

Modeling and simulation of human movement has the potential to improve the design of medical devices and rehabilitation devices by enabling the identification of cause-effect relationships in individual patients. One such application is the design of ankle foot orthosis (AFO) devices to mitigate the risk of ankle inversion injury during landing. This paper presents a simulation-based stiffness design for an ankle foot orthosis (AFO) that can help to mitigate the risk of ankle inversion injury during landing. The study was conducted using OpenSim to simulate 3D human movement with and without the AFO. The injury risk was evaluated using maximum subtalar angle during landing from free fall onto a 20 degree inclined plane. Results showed that increasing AFO translational stiffness generally reduced ankle inversion angle. The relationship between stiffness directions was nonlinear. Multiple stiffness combinations successfully kept subtalar angles below 25 degrees. High stiffness in all three directions produced the lowest inversion angles (around 19 degrees). No single stiffness value is required as this study shows that there are multiple safe configurations. The results support personalized AFO design, tailoring the directional stiffness to patient specific needs. Some patient trials are still needed to verify the design, but the simulation based design reduces the dependence on repeated patient trials.

provide information on external muscle forces and joint loads. This information is used to assess the risk of injury during landing. The study was conducted using OpenSim to simulate 3D human movement with and without the AFO. The injury risk was evaluated using maximum subtalar angle during landing from free fall onto a 20 degree inclined plane. Results showed that increasing AFO translational stiffness generally reduced ankle inversion angle. The relationship between stiffness directions was nonlinear. Multiple stiffness combinations successfully kept subtalar angles below 25 degrees. High stiffness in all three directions produced the lowest inversion angles (around 19 degrees). No single stiffness value is required as this study shows that there are multiple safe configurations. The results support personalized AFO design, tailoring the directional stiffness to patient specific needs. Some patient trials are still needed to verify the design, but the simulation based design reduces the dependence on repeated patient trials.

Computational simulations were performed using human movement models with and without a passive AFO to assess the AFO usability for the ankle-foot orthosis that prevents the risk from transferring with respect to the footplate. The design of Experiment (DOE) methodology was used to assess sensitivity between the three principal directions of the AFO stiffness. Results revealed that the ankle inversion angle was less than 25 degrees when providing larger values of translational stiffness were used, although a nonlinear behavior was observed between the three principal directions of the AFO stiffness, for which injury risk design configurations were derived.

In clinical practice it is important to find the ideal AFO for a given patient using several stiffness with different characteristics, namely stiffness and flexibility. Thus, currently, simulation models are already used to explore the influence of this parameter within separating the constant measures of the individual [3]. It is important to note that the flexibility of an ankle-foot orthosis depends on

11. Torres, M. S. B. L. Instituto Superior de Engenharia de Lisboa, Instituto Politécnico de Lisboa, av. Conselheiro António Augusto, 1, 1501-801 Lisboa, Portugal; m.silva@isep.ipv.pt (m.silva@isep.ipv.pt)
12. Silva, M. S. B. L. Instituto Superior de Engenharia de Lisboa, Instituto Politécnico de Lisboa, av. Conselheiro António Augusto, 1, 1501-801 Lisboa, Portugal; m.silva@isep.ipv.pt (m.silva@isep.ipv.pt)
13. A. Cavaleiro, Instituto Politécnico de Lisboa, Instituto Superior de Engenharia de Lisboa, av. Conselheiro António Augusto, 1, 1501-801 Lisboa, Portugal; a.cavaleiro@isep.ipv.pt (a.cavaleiro@isep.ipv.pt)
14. A. Cavaleiro, Instituto Politécnico de Lisboa, Instituto Superior de Engenharia de Lisboa, av. Conselheiro António Augusto, 1, 1501-801 Lisboa, Portugal; a.cavaleiro@isep.ipv.pt (a.cavaleiro@isep.ipv.pt)
15. A. Cavaleiro, Instituto Politécnico de Lisboa, Instituto Superior de Engenharia de Lisboa, av. Conselheiro António Augusto, 1, 1501-801 Lisboa, Portugal; a.cavaleiro@isep.ipv.pt (a.cavaleiro@isep.ipv.pt)

Authorised for personal use only: University of Worcester, Download Date January 28, 2025 at 22:42:00 UTC from IP 193.50.135.100. See also: [https://doi.org/10.1080/00140139.2025.2444444](#)

[Download](#)

Ankle_Foot_Orthosis_AFO_stiffness_design_for_mitigation_of_ankle_inversion_injury_2_.pdf (2.21 MB)



1/28/26 Literature Search - Use, tolerability, benefits and side effects of orthotic devices in Charcot-Marie-Tooth disease

SIERRA LOOSEN - Jan 28, 2026, 5:23 PM CST

Title: Literature search - Use, tolerability, benefits and side effects of orthotic devices in Charcot-Marie-Tooth disease

Date: 1/28/26

Content by: Sierra

Present: N/A

Goals: Read the study about the use, tolerability, and side effects of orthotic devices in a disease similar to muscular dystrophy

Link: <https://pmc.ncbi.nlm.nih.gov/articles/PMC11041609/>

Content:

- This study focused on using AFOs to mitigate symptoms in Charcot-Marie-Tooth disease
 - this is similar to muscular dystrophy in that CMT causes distal motor weakness and foot deformities and it is also a genetically inherited disease
 - Orthotic devices such as shoe inserts, orthopedic shoes and AFOs are assistive devices in the management of CMT patients in order to alleviate symptoms, improve gait and improve quality of life
 - 49% of CMT patients use AFOs according to this study
- Patients often find that the prescribed orthotic device is uncomfortable or unsuitable and is therefore used less than is prescribed or advisable, sometimes it isn't used at all
- AFOs can be divided into:
 - plastic AFOs
 - support plantar and dorsal flexion ankle movements
 - elastic band AFOs
 - which only assist in foot dorsiflexion
- This study found that despite users understanding the potential benefits of AFOs and identified drawbacks (which might be remedied), they were frustrated by the difficulties of translating this into practice
 - since AFOs are not strictly necessary for walking, the physical and psychological discomfort associated with their use as well as supply issues may have an important role in the patient's decision whether to use them or not
 - CMT patients, especially women, had poor compliance with using their prescribed AFOs or orthopedic shoes due to their poor aesthetics
 - this directly relates to our project as our patient requested that the AFO to treat HSHD be inconspicuous in nature as to not draw unwanted attention to the device, previous semesters of work have lead to an aesthetically pleasing product that the client and patient like
 - The study found that only 20% of the CMT patients used their prescribed AFO outside the house
 - There was also a high percentage of users reporting that they experiences pain and skin irritation while wearing their AFO, which also contributed to the lack of wearing it
- The study analyzed answers from 266 CMT patients
 - 185 subjects were prescribed lower limb orthoses, but 35/185 of them never used them
 - Among the 150 who did use them, 103 reported a current use while 47 of them abandoned their device
 - 61 of the 103 users were using AFOs
 - Complications were reported by 59% of patients, and were frequently related to AFOs (69%) as compared with shoe inserts and orthopedic shoes
 - AFO users complained mostly of skin reddening and moderate to severe pain
 - When asked for reasons not to use AFOs, discomfort/pain, emotional distress, and size were the most reported

Conclusions/action items:

This study highlights the fact that many patients who would benefit from the use of AFOs do not use for various reasons such as being aesthetically unpleasing, or causing pain and discomfort. This raises ethical questions about balancing the benefits against potential harm of using an AFO. This also emphasizes the important of ensuring we create something that our patient will actually wear, and not abandon using due to aesthetic reasons or discomfort. As a team, we need to ensure that our product successfully assists in the mitigation of symptoms for the FSHD patient and alleviate any worries the patient has that would stop her from wearing the device on a regular basis.

Neurosciences



Original research

Use, tolerability, benefits and side effects of orthotic devices in Charcot-Marie-Tooth disease

Alessandro Bertini,¹ Fiore Mangione,^{1,2} Gian Maria Fabrizi,^{3,5} Angelo Schenone,^{6,7,8} Lucio Santoro,⁹ Tolino Cavallaro,¹⁰ Matteo Tagliapietra,¹¹ Marina Grandi,¹² Stefano Cogli Pavolini,¹³ and Matteo Falzone,¹⁴ Isabella Allegri,¹⁵ Luca Padias,¹⁶ Costanza Pozzaglia,¹⁷ Irene Torroze,^{18,19} Beonora Coviak,¹ Paolo Saviet,¹ Andrea Quartrone,¹¹ Paola Volentini,²⁰ Stefano Tozza,²¹ Luca Goetti,²² Massimo Russo,²³ Anna Mazzino,²⁴ Giuseppe Vira,²⁵ Valeria Prada,^{26,27} Riccardo Zucchino,²⁸ Francesco Ferraro,²⁹ Chiara Pisotta,³⁰ Davide Pareyson,³¹ for the Italian CMT Network

Additional supplemental material is published online with this article. Please visit the journal website for details on how to access this online supplement.

Correspondence to: Dr. Alessandro Bertini, 1, viale dell'Università, 10125, Padova, Italy (a.bertini@unipadova.it)

Supplementary material is published online with this article. Please visit the journal website for details on how to access this online supplement.

Received: 11 August 2021
Accepted: 10 October 2021
Published online: 19 November 2021

Check for updates

© Bertini et al. 2021
This article is distributed under the terms of the Creative Commons Attribution License (CC BY) 4.0 International License, which permits unrestricted use, distribution, and reproduction in any medium, provided the original author(s) and the source are credited.

ABSTRACT
Background: Shoe inserts, orthopedic shoes, ankle-foot orthoses (AFOs) are important elements in Charcot-Marie-Tooth disease (CMT) management, but little is known about use, benefits, and tolerability in daily life.
Methods: We also assessed in Italian CMT Registry patients an online ad hoc questionnaire regarding use, complications, and perceived benefits/tolerability associated with shoe inserts, orthopedic shoes, AFOs and their combinations. Patients were also asked to fill in the Quebec User Evaluation of Satisfaction with Assistive Technology questionnaire rating satisfaction with current use of AFO and related services.
Results: 740 completed surveys from 355 CMT patients, seventy per cent of subjects were prescribed custom built orthoses, but 115% did not use them. Over 1,000 subjects wore shoe inserts, 15% orthopedic shoes and 20% AFOs. Frequency of use and duration was high: 48% for shoe inserts, 25% for orthopedic shoes and 21% for AFOs. Complications were reported by 35% of patients and were most frequently related to AFOs (aching, skin ulcers, experienced greater mechanical stresses and reduced tolerability as compared with shoe inserts). Use of AFOs and orthopedic shoes (as well as shoe inserts, respectively) showed greater degree of foot weakness, customisation and timing for customisation were determinant factors in AFOs' tolerability. Quality of foot footwear and follow-up services were perceived as weak.
Conclusions: The majority of CMT patients is prescribed shoe inserts, orthopedic shoes and/or AFOs, although perceived benefits and tolerability are rather great. There is a high rate of complications, particularly inappropriate prescriptions and orthotists' errors in diagnosis, which reduce the use of AFOs. A rational, patient-oriented and multidisciplinary approach to orthoses prescription must be encouraged.

BACKGROUND
Distal motor weakness and foot deformities are the most disabling symptoms in Charcot-Marie-Tooth disease (CMT), the most prevalent group of inherited peripheral neuropathies, causing disability in

WHAT IS ALREADY KNOWN ON THIS TOPIC?
→ Distal weakness is an important manifestation in Charcot-Marie-Tooth disease (CMT) management, but little is known about use, benefits and tolerability in daily life.
WHAT THIS STUDY ADDS
→ Although 70% of patients were prescribed foot orthoses, 11% of them did not use the devices, 37% of us no longer abandoned them and 50% experienced complications.
→ Disease severity, degree and distribution of foot weakness, and both performance and timing of customisation impacted on ankle-foot orthoses (AFOs) benefits and tolerability.
→ At least 17% and possibly up to 21% of AFO prescriptions might be inappropriate according to patients.
HOW THIS STUDY MIGHT AFFECT RESEARCH, PRACTICE OR POLICY
→ A patient-tailored and rational approach in prescribing AFOs is needed and is likely to improve compliance and tolerability, limiting waste of resources.

less, associated with sensory deficits and decreased toe-clear step reaction reflexes are other characteristic findings.
Orthotic devices such as shoe inserts, orthopedic shoes and ankle-foot orthoses (AFOs) are important assistive devices in the management of CMT patients, by alleviating symptoms, improving gait, and helping energy conservation (1-3) during daily life. Their reported use ranges between 12% and 22% for shoe inserts and 21% and 47% for AFOs, across different large cohorts of CMT patients.
However, data regarding the employment of the different types of orthoses in real life and the actual patient issues and compliance are still scarce. Indeed, clinical experience indicates that patients often find the prescribed orthotic device

[Download](#)

jnnp-2023-332422.pdf (959 kB)



1/28/26 Literature Search - WHO standards for prosthetics and orthotics

SIERRA LOOSEN - Jan 28, 2026, 5:48 PM CST

Title: WHO standards for prosthetics and orthotics

Date: 1/28/26

Content by: Sierra

Present: N/A

Goals: Read about the broader ethical implications regarding orthotics according to the World Health Organization

Content:

- Prostheses and orthoses enable people with physical impairments or functional limitations to live healthy, productive, independent, dignified lives and to participate in education, the labor market and social life
 - this connects AFO use to fundamental human rights and shows how beneficial AFOs can be in including disabled individuals into society
- The use of prostheses or orthoses can reduce the need for formal health care, support services, long term care and caregivers
- Without access to prostheses or orthoses, people who need them are often excluded, isolated and locked into poverty, which increases the burden of morbidity and disability
- The World Health Organization estimates that today, only one in ten people in need has access to assistive products, including prosthesis and orthoses
 - this is due to their high cost and lack of awareness, availability, trained personnel, policy and financing
 - this addresses ethical concerns of AFOs regarding equity and access to these resources based on socioeconomic status
- The WHO is working to improve access to assistive devices globally and help aid those who would benefit from using these devices

Conclusions/action items:

It is important for our team to address some of these concerns that the World Health Organization has outlined. We need to make a device that could easily be replicated and adjusted for other patients to use. Although the cost is not a direct concern for our team, as the BME department is so graciously funding this project, we need to still consider cost. The cost should be reasonable so that if the product is replicated, it can be easily bought by other individuals who may want to use it. This article also shows the importance of AFOs in assisting individuals with disabilities to do every day tasks and be woven into the fabric of society without set backs.

SIERRA LOOSEN - Jan 28, 2026, 5:32 PM CST



[Download](#)

9789241512480-part1-eng.pdf (4.3 MB)



1/28/26 Reviewing Previous AFO Teams' Work

SIERRA LOOSEN - Jan 28, 2026, 2:50 PM CST

Title: Reviewing Previous AFO Teams' Work

Date: 1/28/26

Content by: Sierra (Reports by previous AFO teams)

Present: N/A

Goals: Read through the final reports from the previous 3 semesters to understand what work has already been done on this project, as well as what still needs to be worked on

Content:

Background/client/user info

- The client is Debbie Eggleston and the user of this product is her daughter who has Facioscapulohumeral Dystrophy (FSHD)
 - FSHD is a common type of muscular dystrophy, and it is a genetic disorder that leads to progressive muscle weakness
 - There is no cure for FSHD, but treatments include physical therapy, orthotics, and surgery
- The project aims to create a discrete ankle-foot orthosis as current AFO designs are bulky and would draw unwanted attention
 - The user is a high school aged girl who would feel uncomfortable wearing a large AFO while at school and doing activities
- The AFO should support dorsiflexion to prevent foot drop, provide flexibility for daily activities, and prevent ankle inversion
 - foot drop occurs when the foot's muscles are too weak to support the foot in a normal position, leading to an excess drop of the foot, affecting the gait when walking
 - ankle inversion is where the foot rolls inwards which is potentially harmful to the tendons of the ankle
- The goal is to create something that can be replicated and be made customizable to other young individuals who would want an inconspicuous AFO

Fall 2024

- The final design combined two of the preliminary designs (Bungee Brace and Strap Brace) and added a carbon fiber support that runs from the calf down along the inside of the foot
- Materials included nylon, carbon fiber, PLA, black bungee cord, a lock lace, and gel pads
- The design is a compression sock base with various nylon straps around it to secure it in place, and has a bungee cord with a lock lace to further secure it
- Testing included testing of different bungee cord strengths to see what would have the most effective dorsiflexion support
- Testing also included simulations in SolidWorks to evaluate the structural integrity of the 3D printed PLA and carbon fiber pieces
- Future work
 - replace the straps and compression sleeve for a slimmer and more cohesive appearance
 - look into custom molding carbon fiber
 - incorporate user's foot insert into the design
 - in person testing with the user
 - improve the rigid inversion support

Spring 2025

- The final design was the We Support U design, which balances appearance with functionality
- The CF-PLA supports will prevent ankle inversion and eversion at the subtalar joint, the gel pad will reduce discomfort and rubbing on the ankle joint, and the elastic straps will allow for adjustability and customizability
- Materials included the CF-PLA, a foot sleeve composed of a blend of nylon, polyester, and latex, and a thin black bungee cord
- This semester focused on patient dimensional specificity
- The team scanned the cast using the Creality RaptorX gun in the makerspace
- The final inversion support design had two rigid supports with holes to prevent discomfort on or around the malleoli at the ankles, there are two velcro straps located around the shin and underneath the heel
 - there is also a double layered mesh foam on the inside of both supports

- the full assembly of the brace involves placing the inversion support and securing it in the right spot with the velcro straps going around the ankle, and the compression sock with bungee cord mechanism slides over the inversion supports and the bungee cord is tightened
- Testing included MTS testing of the rigid support, where the 35% infill failed first under the 260 N load
- They also completed force plate testing
- They sent the brace to the client and user for them to test, and there was a consistent pain point on the medial side of the foot for both braces
- Future work
 - integrate the bungee mechanism compression sleeve and the rigid support into one cohesive device
 - improve the bungee cord mechanism since the user's condition has progressed
 - have the client travel to Madison to 3D scan the patient's foot to improve the dimensions of the device and mitigate localized discomfort

Fall 2025

- Final design includes 3D printed medial and lateral sides to prevent ankle inversion and eversion, polyester strap to support dorsiflexion, with layers of padding to ensure comfort
- Materials included carbon fiber reinforced PLA, elastic material for dorsiflexion straps, nylon straps for attachment and adjustability, velcro pieces, and padding
- It was determined that the second layer of padding relieved the pain points around the malleoli, and the client and patient approved of the new aesthetic appeal of the design
- Various tests were performed when the client and user traveled to Madison which helped improve the design
- Future work
 - Mediolateral supports will be extended to the floor to reduce downward slipping
 - integrate a TPU strap instead of polyester since testing suggested that TPU is more durable
 - potentially collaborate with University of Michigan's BME department to do some testing since the client lives just 15 minutes from Ann Arbor

Conclusions/action items:

The design has been greatly modified and improved over the last three semesters. The main goals have been achieved and the AFO seems to improve the user's walking. Necessary changes and adjustments were made to ensure the user was comfortable. The design is in its final stages and hopefully there will be a fully finished project at the end of this semester.



2/3/25 Literature Search-Costs of AFOs

SIERRA LOOSEN - Feb 03, 2026, 4:32 PM CST

Title: Literature Search-Cost of AFOs

Date: 2/3/26

Content by: Sierra

Present: N/A

Goals: Learn more about the costs of AFOs to update the economic impact section of the PDS

Citation: A. N. Spector, *Price survey of assistive devices and supports for persons with disabilities: final report*. in Working paper / Applied Research Branch, Strategic Policy, Human Resources Development Canada. Gatineau, Quebec: Applied Research Branch, Human Resources Development Canada, 2003.

Content:

- This is a report that summarizes the results of a price survey of assistive devices and supports for people with disabilities
 - the price survey was done in 2001, so some of the prices may not be accurate anymore
- cost depends on the type of AFO
 - AFO consisting of a spring wire connecting a shoe to a band at the calf (which is similar to what Maggie has from the doctors) had an average cost of \$376.25
 - A thermoplastic AFO takes the weight off of the heel and ankle via a band in the lower knee region and plastic form down the calf had an average cost of \$943.02

Citation:

Daniel2876, "How Much Does An AFO (Ankle Foot Orthosis) Cost?," Rinella Prosthetics & Orthotics. Accessed: Feb. 03, 2026. [Online]. Available: <https://rinellapo.com/how-much-does-an-afo-cost/>

Content:

- This website similarly states that the price of an AFO really depends on the type you get, as well as the level of customization the patient requires
- AFOs that are purchased off the shelf are obviously much cheaper than custom made AFOs
- Often, there is an additional cost to have padding inserted on the AFO
- The cost of an AFO can range from \$59 to \$1053

Conclusions/action items:

In conclusion, AFOs can be quite expensive to purchase, especially without insurance and if a high level of customization is necessary. This further drives the point that we should be considering the cost to fabricate the AFO we make. Although our project is being funded by the BME department, it is still essential for our team to consider that cost is something to think about while fabricating our product to ensure a more inclusive design. Should our design be recreated, it should be as low cost as possible to make it accessible to as many patients as possible.



2/3/26 Literature Search-Ankle Foot Orthosis (AFO) Market Report Overview

SIERRA LOOSEN - Feb 03, 2026, 5:00 PM CST

Title: Ankle Foot Orthosis (AFO) Market Report Overview

Date: 2/3/26

Content by: Sierra

Present: N/A

Goals: Research more information to include in the economic impacts section of the PDS

Citation:

“Ankle Foot Orthosis (AFO) Market Size, Share | Growth [2034].” Accessed: Feb. 03, 2026. [Online]. Available: <https://www.proficientmarketinsights.com/market-reports/ankle-foot-orthosis-afo-market-1334>

Content:

- The global AFO market is expected to grow to \$240 million in 2026
 - further expected to grow to \$330 million by 2034 as demand rises for orthopedic mobility solutions
- Incorporation of smart technology and lightweight materials will account for nearly 40% of product upgrades as new biomechanical innovations continue to transform modern AFO designs
- Over 50% of the new AFO demand is due to a rise in neurological and musculoskeletal conditions
 - associated with aging populations that are developing a need for mobility aids such as AFOs
- The restraining factors and impediments to AFO market growth are the high costs associated with getting an AFO as well as a lack of awareness (among both healthcare professionals and patients)
 - issues related to discomfort, fit, and aesthetics of AFOs can further deter patient compliance in using an AFO
- Advanced carbon fiber and thermoplastic designs will represent 35% of the market by 2034
 - this is driven by patient comfort as well as the ability to make custom AFOs with these materials
 - we as a team are looking into incorporating carbon fiber into our design to make the product look sleek and finished while also providing the necessary support
- Carbon fiber AFOs will dominate the market with approximately 45% of the market share due to their lightweight durability.

Conclusions/action items:

This article emphasizes the global impact of AFOs and explains that there is an upward trend in the need for AFOs. This helps to understand the global implications of our project, even though we are specifically working on one custom AFO for one patient. This further shows that as the need for AFOs in the population increases, it is important to make them accessible to people by raising awareness of the benefits of AFOs, while also ensuring the designs are cost-friendly so that people who need them can actually afford them.



2/3/26 Literature Search-Effects of Carbon versus Plastic Ankle Foot Orthoses on Gait Outcomes and Energy Cost in Patients with Chronic Stroke

SIERRA LOOSEN - Feb 03, 2026, 5:24 PM CST

Title: Effects of Carbon versus Plastic Ankle Foot Orthoses on Gait Outcomes and Energy Cost in Patients with Chronic Stroke

Date: 2/3/26

Content by: Sierra

Present: N/A

Goals: Complete more research on carbon fiber AFOs to determine if we should implement CF in our design

Citation:

D. RIMAUD, R. TESTA, G. Y. MILLET, and P. CALMELS, "EFFECTS OF CARBON VERSUS PLASTIC ANKLE FOOT ORTHOSES ON GAIT OUTCOMES AND ENERGY COST IN PATIENTS WITH CHRONIC STROKE," *J Rehabil Med*, vol. 56, p. 35213, Aug. 2024, doi: [10.2340/jrm.v56.35213](https://doi.org/10.2340/jrm.v56.35213).

Content:

- Plastic AFOs are widely used in clinical practice
 - historically, AFOs have been fabricated as a custom-made rigid plastic piece, designed to partially immobilize the ankle joint at a neutral position in one or more plates
 - the plastics are typically made of thermoplastics like polypropylene
 - this material is widely used due to its relatively low cost, good aesthetics, and ease of cleaning
- However, composite materials, like carbon fibers, are now widely available for incorporation into orthoses
 - A composite AFO is able to significantly improve pathological walking by storing energy during deformation, and increasing push-off during the pre-swing phase
 - Studies have shown that a composite AFO can decrease the energy expenditure of patients with disabilities
 - limited research has been conducted to compare composite AFOs with plastic manufacture AFOs
- this study focuses on exploring the difference in walking performance in stroke patients who have worn a new standard carbon fiber AFO or their personal custom-made plastic AFO
 - compared effects of an "off the shelf" composite AFO with a custom made plastic AFO and with a control condition of wearing no orthosis
- Participants were evaluated using:
 - walking performance - distance covered, walking speed, number of steps, and cadence
 - energy cost of walking - heart rate and VO2 were measured at rest for 10 minutes before testing and continuously during testing
 - gait analysis - a motion capture system was used to evaluate the participants' gait cycles
 - satisfaction questionnaire - participants were given a 7 question survey which evaluated how comfortable they were while walking as well as which AFO they preferred
- Results
 - over 60% of the participants felt more comfortable while walking in the Carbon fiber AFO and 67% of them wished to keep the C-AFO at the end of the study

- using an off the shelf composite AFO significantly improved walking performance and energy cost, to the same degree as their custom-made thermoplastic AFO when compared to a control condition without an AFO
 - no differences between the results for the 2 types of AFO were observed despite their differing designs
- The C-AFO improved gait outcomes and energy cost to the same extent as the plastic custom made AFOs

Conclusions/action items:

This study found that there was no significant difference in the effects of a carbon fiber composite AFO when compared to a custom thermoplastic AFO. Both proved to improve patient outcomes regarding gait and expending less energy while walking. The team will need to do further research to determine if it is worth it to incorporate carbon fiber into our design, as the necessary training to work with carbon fiber in the automotive lab can be quite extensive.



2/5/26 Literature Search - Mechanical Properties of Additively Manufactured Thermoplastic Polyurethane (TPU)

SIERRA LOOSEN - Feb 05, 2026, 9:28 AM CST

Title: Literature Search-Mechanical Properties of Additively Manufactured Thermoplastic Polyurethane (TPU) Material Affected by Various Processing Parameters

Date: 2/5/26

Content by: Sierra

Present: N/A

Goals: Research the properties of TPU to potentially implement into the design

Citation:

T. Xu, W. Shen, X. Lin, and Y. M. Xie, "Mechanical Properties of Additively Manufactured Thermoplastic Polyurethane (TPU) Material Affected by Various Processing Parameters," *Polymers (Basel)*, vol. 12, no. 12, p. 3010, Dec. 2020, doi: [10.3390/polym12123010](https://doi.org/10.3390/polym12123010).

Content:

- Thermoplastic polyurethane (TPU) is a polymer material that has high ductility, good hydrolysis resistance, excellent biocompatibility and great abrasion resistance
 - These properties make it good for structures that require high ductility, such as energy-absorbing structures and wearable devices
- This study focused on printing TPU using selective laser sintering (SLS) which uses a laser to sinter powder layer by layer to form functional end-use components
- The build orientation has a significant influence on the mechanical properties of additively manufactured parts
- This study conducted tests on TPU dumb-bell specimens that were manufactured with an industrial SLS printer
 - The effects of three processing parameters on the mechanical properties of 3D printed TPU were investigated including build orientation, post-processing, and mix ratio

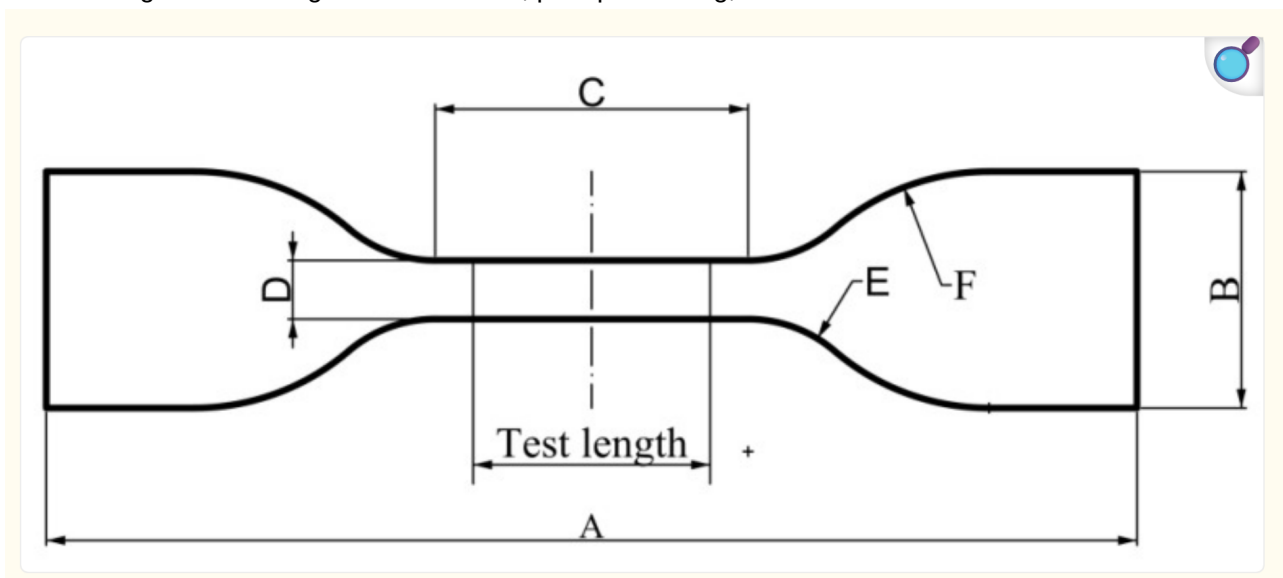

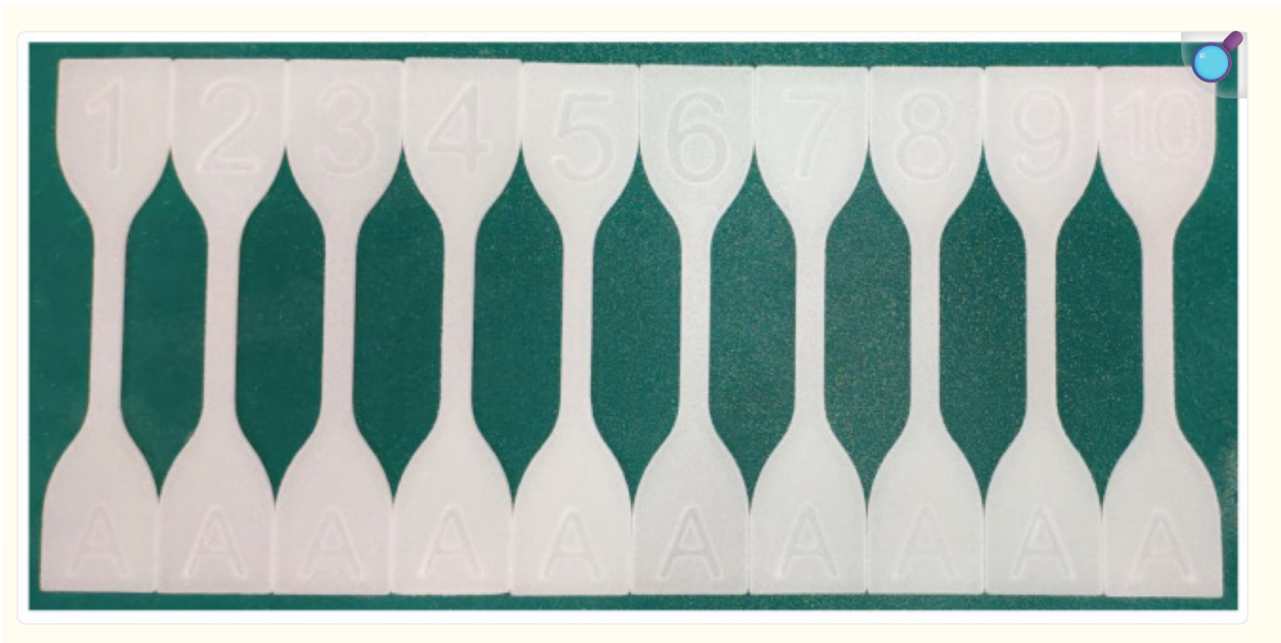

- - Print orientation refers to which orientation a printed part is placed on the print platform
 - the printed part may show an anisotropic property, so the goal was to analyze the effect of orientation on the mechanical properties of 3D printed TPU parts
 - three orientations were analyzed including flat, on-edge, and upright

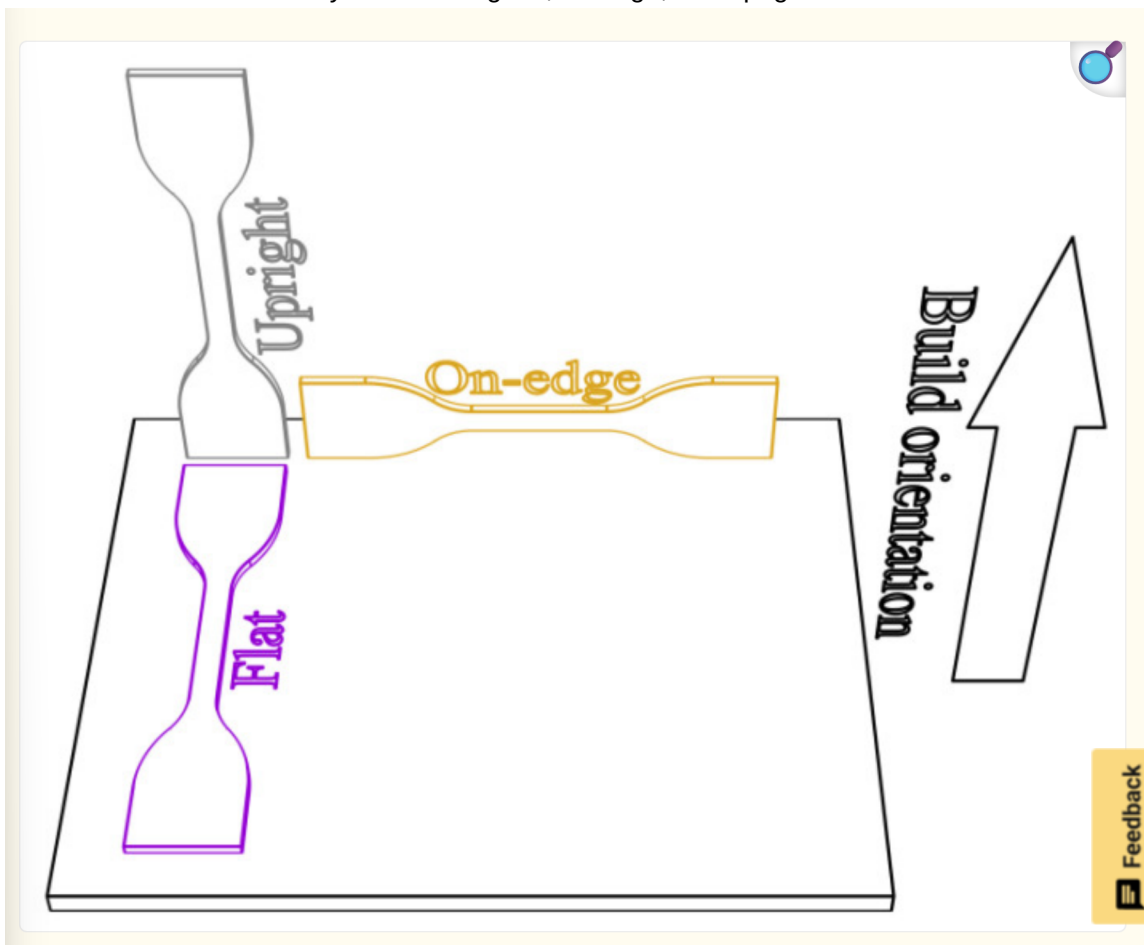

- - Post-processing
 - the chemical solvent would react with the surface of the printed part, which may change the composition of the part
 - the chemical treatment was performed by immersing the printed part into an amide solvent for 3 minutes

- Powder Mix Ratio
 - After SLS processing, the un-sintered powder was often recycled and reused
 - TPU particles may stick together during the SLS process so the large particles were filtered out
 - The temperature in the SLS machine may affect the thermoplastic properties of the un-sintered powder
 - The study investigated three max ratios commonly used in industry
 - 30% new powder, 70% new powder
 - 50%/50%
 - 100% new powder
- Tensile testing
 - 10kN universal testing machine with a 250 N load cell was used
- Results
 - the specimens printed in on-edge orientation have a larger strain capacity compared to specimens printed in flat orientation
 - Specimens printed in upright orientation show a significant drop in both tensile strength and strain capacity
 - samples printed in the flat orientation showed larger variations in the test results than the others
 -

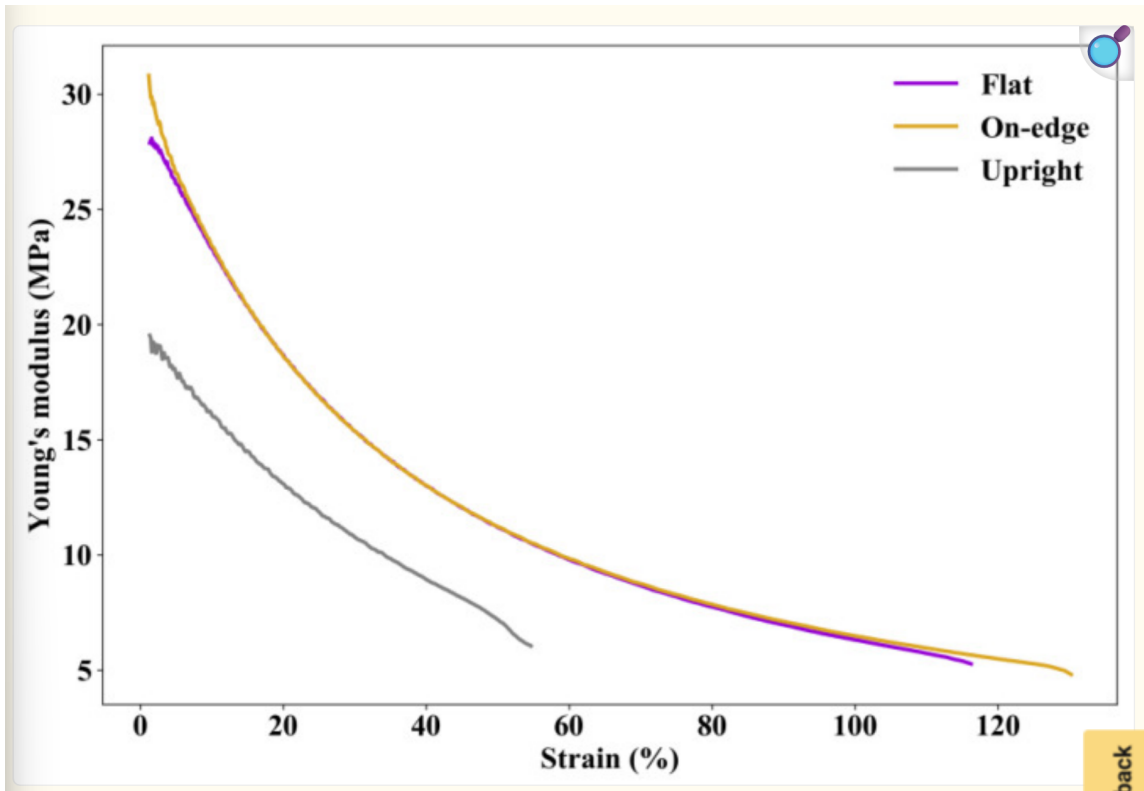

- increasing the mix ration of the new powder increased mechanical properties
 - This obviously wastes a lot of material however if you aren't reusing any of the powder
- TPU specimens printed in flat and on-edge orientations exhibit similar superior mechanical properties
 - for specimens printed in upright orientation, the tensile strength is about 40% lower and deformability is about 60% lower compared to the other two orientations
- post-processing can substantially enhance the deformability of the specimens
 - for flat orientations, deformability can be increased by 40.1%
 - for on-edge orientations, deformability can be increased by 73.5%

- for upright orientations, deformability can be increased by 41.0%

Conclusions/action items:

This study focused on analyzing how various steps of printing TPU parts impacted the mechanical properties of the final product. This relates to our project as we are planning to implement a TPU strap into the final design, but we need to do further research and testing to determine how to apply the ideal forces to support dorsiflexion. The parameter from this study that would most apply to our project would be that printing a strap in different orientations could affect the mechanical properties of the final printed part. We also need to investigate what infill rate to print the strap at since that also affects the mechanical properties.



2/11/26 Literature Search-Ballistic Fabrics

SIERRA LOOSEN - Feb 11, 2026, 7:34 PM CST

Title: Literature Search-Ballistic Nylon

Date: 2/11/26

Content by: Sierra

Present: N/A

Goals: Learn more about the materials we are considering for dorsiflexion support

Citation:

"Ballistic Fabrics," TVF. Accessed: Feb. 11, 2026. [Online]. Available: <https://www.tvfinc.com/article/ballistic-fabrics/>

Content:

- Fun Fact - Ballistic nylon was first created during WWII as a protective fabric to be used in military jackets, it was intended to shield soldiers from exploding fragments and shrapnel
- Ballistic fabric is typically constructed from nylon 6, but ballistic nylon features the "ballistic weave", which is a tight basket-weave pattern
 - Common weaves include 2x2, or 3x3, which means that multiple threads are woven together in each direction which creates a denser and stronger fabric
 - the denier is a measure of the weight and thickness of the fiber which therefore determines the mechanical properties of the nylon, this value can range widely
 - standard ballistic fabric is typically 840D or higher
 - 1050D and even 1680D are common for heavy-duty applications (we likely wouldn't need it to be this high)
 - ballistic fabric is often treated with coatings such as polyurethane or PVC or additional durability, this can also enhance water resistance, UV resistance, and abrasion protection
- Properties of ballistic fabrics
 - abrasion resistance - the dense weave and high denier means that ballistic fabric withstands repeated abrasion better than most other fabrics, the surface also has a smooth finish to reduce friction
 - tensile strength - ballistic fabric has a high tensile strength, which makes it resistant to tearing and puncturing
 - weather resistance - if finished with the appropriate coating, ballistic fiber can resist moisture and UV exposure, making it ideal for outdoor environments
- Tensile strength testing (which we would likely do) is often used to evaluate ballistic fibers, and high denier ballistic fabrics generally score high on tensile strength tests

Conclusions/action items:

Ballistic nylon could be a very good option for us to incorporate into our design for dorsiflexion support. This material is very durable, and has good tensile strength which are both aspects we want in the final design. It also has different

deniers, depending on the weight and thickness of the fiber, so we would be able to test different kinds of this fabric to determine what would be best for our situation.



2/11/26 Literature Search-Polyester-Elastane Blends

SIERRA LOOSEN - Feb 11, 2026, 8:11 PM CST

Title: Literature Search-Polyester-Elastane Blends

Date: 2/11/26

Content by: Sierra

Present: N/A

Goals: Learn more about polyester and elastane fabric blends

Citation:

N. Crafts, "Are Polyester And Elastane Stretchy Fabrics?" Accessed: Feb. 11, 2026. [Online]. Available: <https://northshorecrafts.com/is-polyester-and-elastane-stretchy/>

Content:

- Polyester
 - polyester fibers on their own have relatively low elasticity compared to natural fibers like cotton or wool, the lack of elasticity is due to the molecular structure of polyester which is composed of long chains of repeating units
 - The chains are tightly packed together and therefore do not easily stretch or deform
 - Garments made from polyester alone often have limited stretch and feel stiff, which is why polyester is often combined with other fibers
 - Polyester fabrics also have minimal mechanical stretch
 - even if the fibers themselves have some stretch, the tight weave of the fabric restricts their ability to stretch, and then recover back to its original length
- Elastane
 - also known as spandex
 - a synthetic fiber widely used in the textile industry due to its stretchiness
 - is a highly elastic material, can often be stretched several times its original length, and will return back to its original shape when released
 - Elastane fibers can be stretched up to 500% of their original length, which make them very flexible and resilient
 - the elasticity is due to the use of a special polymer that is spun into fibers during the manufacturing process
 - When elastane fibers are woven into fabrics, the resulting material gains the same stretchability as the fibers themselves
 - elastane woven fabrics have the ability to stretch easily in all directions
 - more elastane fibers leads to greater stretchiness
- Polyester and elastane combined
 - When these two types of fibers are blended together, they result in a fabric that offers stretch and flexibility
 - polyester, which is known for its durability and wrinkle resistance, provides the structure and stability of the fabric
 - elastance provides the stretchiness

- This blend is an ideal choice for garments that require a snug fit or need to accommodate body movements
- Different fabrics have different ratios of polyester to elastane, which is something we could play around with in testing
- polyester-elastane blended fabrics are known for their moisture wicking properties (which is why this blend is often used in activewear clothing)
- over time, polyester and elastane fabrics may develop signs of wear and tear, like pilling or deterioration

Conclusions/action items:

A polyester-elastane blend would provide our design with a material that is both stretchy and stable. However, this may not be a good choice if we want the design to be durable over time since this material is not as strong. Pilling of the polyester-elastane strap may occur over time, which could alter the effectiveness of the AFO and require frequent replacement.



2/11/26 Literature Search-Thermoplastic Polyurethane

SIERRA LOOSEN - Feb 11, 2026, 8:29 PM CST

Title: Literature Search-Thermoplastic Polyurethane (TPU)

Date: 2/11/26

Content by: Sierra

Present: N/A

Goals: Learn more about the properties of TPU for consideration in our design

Citations:

[1] "Thermoplastic Polyurethane (TPU) Material," FOW Mould. Accessed: Feb. 11, 2026. [Online]. Available: <https://www.immould.com/tpu-material/>

[2] Neway, "Thermoplastic Polyurethane (TPU)," Superalloy High temperature alloy Parts Manufacturer. Accessed: Feb. 11, 2026. [Online]. Available: <https://www.newayaerotech.com/pt/services/plastic-3d-printing/thermoplastic-polyurethane-tpu?utm>

[3] kimatedor, "Tpu filament: the good, the bad, and the ugly," Massivit. Accessed: Feb. 11, 2026. [Online]. Available: <https://www.massivit3d.com/blog/tpu-filament-the-good-the-bad-and-the-ugly/>

Content:

- TPU is a unique blend of rubber and plastic, known for its high elasticity, strength, and excellent processing capabilities
- The molecular structure of TPU allows it to behave like both an elastomer and thermoplastic elastomer
- A variety of different TPU can be produced by altering the ratio, structure, and molecular weight of the reaction compounds
- One feature of TPU is its reversible cross-linking through intermolecular hydrogen bonds
 - when heated or dissolved, these bonds weaken which makes the material moldable
 - when cooled, the bonds re-form and the material's original properties are restored
- Properties
 - abrasion resistance - renowned for its exceptional abrasion resistance
 - chemical resistance - resists oils, greases, and many solvents, maintains its integrity in harsh environments
 - low-temperature flexibility - remains flexible and function down to -50 degrees C
 - elasticity and toughness - has both high elasticity as well as high tensile strength (up to 70 MPa) and an elongation at break of up to 1000%
 - Biomedical properties - TPU has excellent biocompatibility which makes it ideal for medical applications
 - non-toxic
 - non-allergenic
 - non-irritating

TPU Properties Table	
Properties	Value
Density (g/cm ³)	1.10–1.25
Melting Point(°C)	150–230
Tensile Strength(MPa)	20–50
Elongation at Break (%)	300–800
Glass Transition Temperature(°C)	-40~-20
Shrinkage Rate (%)	0.35-0.83

- o
- o different types of TPU have different properties that are used for different applications
- o outstanding flexibility with excellent elastic recovery after repeated bending
- o high tear resistance and exceptional abrasion durability for moving components
- o strong impact absorption and vibration damping properties
- o Can be 3D printed, but has some downsides
 - absorbs surrounding moisture
 - must be printed at low speed
 - possible blobs and stringing while printing

Conclusions/action items:

TPU would be a very good option for our design. It is strong and durable, yet also flexible and elastic. This material would be durable over a long period of time and would maintain its mechanical properties throughout repeated use. We can 3D print TPU straps in the makerspace as well. This type of material has also frequently been used in medical devices, so we know it is safe to use.



2/11/26 Comparison of Design Matrix Materials

SIERRA LOOSEN - Feb 11, 2026, 8:33 PM CST

Title: Comparison of Design Matrix Materials

Date: 2/11/26

Content by: Sierra

Present: N/A

Goals: Compare the materials that are included in the design matrix

Content:

The materials listed below are currently being considered for straps on the AFO to aid in dorsiflexion

	Elastic Polyester	TPU (Thermoplastic Polyurethane)	Ballistic Nylon
Pros	<ul style="list-style-type: none"> This type of fabric is both durable (due to the polyester) and stretchy (due to the elastane) Different ratios of polyester to elastane create different mechanical properties, this could be investigated during testing Moisture wicking properties (this blend is often used in athletic wear) 	<ul style="list-style-type: none"> Strong and durable over long periods of time, but also flexible and slightly elastic Has previously been used in medical applications, so we know it is safe to use 	<ul style="list-style-type: none"> Extremely durable (abrasion resistant, high tensile strength, can resist moisture and UV exposure) There are different types based on the weave, as well as the weight and thickness of the fiber so we could play around with testing different kinds
Cons	<ul style="list-style-type: none"> May not be durable over long periods of time, material is subject to pilling and fraying which could alter the effectiveness of the AFO 	<ul style="list-style-type: none"> Issues can arise during 3D printing such as blobs or stringing, and must be printed at very slow speeds, difficult to post process because of its abrasion resistance 	<ul style="list-style-type: none"> Doesn't seem to have any elastic properties, so the strap length would basically remain the same no matter what position the foot is in

Conclusions/action items:

Each of the materials listed above has its individual pros and cons. Some of the materials are more stretchy or more durable than others, while some are not durable over longer periods of time. The team will place these materials in our design matrix and compare them using our established categories based on what characteristics are most important for the success of our design.



3/5/26 Previous Semester's UW Training Documentation

SIERRA LOOSEN - Mar 05, 2026, 7:50 AM CST

Title: Previous Semester's UW Training Documentation

Date: 3/5/26

Content by: Sierra

Present: N/A

Goals: Upload documentation from training in previous semesters

Content:

OVCR Training Information Lookup Tool

University of Wisconsin-Madison



This certifies that Sierra Loosen has completed training for the following course(s):

Course	Assignment	Completion	Expiration
2025-2026 HIPAA Privacy & Security Training	2025-2026 HIPAA Privacy & Security Training	10/23/2025	
Biosafety Required Training	Biosafety Required Training Quiz 2024	10/14/2024	10/14/2029
Chemical Safety: The OSHA Lab Standard	Final Quiz	10/14/2024	
UW Human Subjects Protections Course	Basic/Refresher Course - Human Subjects Research	10/24/2025	10/24/2028

Data Last Imported: 03/05/2026 07:26 AM

Conclusions/action items:

The trainings listed above are the ones I have completed in previous semesters.



3/5/26 Previous Semester's CITI Training Documentation

SIERRA LOOSEN - Mar 05, 2026, 7:53 AM CST

Title: Previous Semester's CITI Training

Date: 3/5/36

Content by: Sierra

Present: N/A

Goals: Upload CITI Training Documentation

Content:

Welcome, Sierra
[Add Institutional Affiliation](#)
[Register as Independent Learner](#)

1 Course Completed 5 Months of Membership

✔ Your registration has been completed successfully.

Show Courses for: University of Wisconsin - Madison Institution List

University of Wisconsin - Madison

Active Courses [Learner Tools](#)
 You have no active courses for this Institution.

Courses Ready to Begin [Learner Tools](#)
 You have no courses ready to begin for this Institution.

Completed Courses [Learner Tools](#)

University of Wisconsin - Madison
UW Human Subjects Protections Course
 Stage 1 - Level 1
[Post-Course Survey](#) ⓘ
 Passed 24-Oct-2025 [Review Course](#) [View - Print - Share Record](#)

Conclusions/action items:

The above screenshot shows my previous completion of the CITI human subjects training during BME 300.



3/5/26 Previous Semester's D+I Lab Training Documentation

SIERRA LOOSEN - Mar 05, 2026, 8:01 AM CST

Title: Previous Semester's D+I Lab Training Documentation

Date: 3/5/26

Content by: Sierra

Present: N/A

Goals: Document previous training at D+I Lab

Content:



Sierra Loosen

ID Number: 908517870
6

Eligibility: CoE
Students

Profile

Program Registrations

Bookings

Memberships

Orders

Invoices

My Memberships				
Membership Type	Start Date	Expiry Date	Renew	Card Info
Machining	Tue, Aug 20 2024	Permanent	Not Renewable	N/A
Laser Cutter	Mon, Feb 19 2024	Permanent	Not Renewable	N/A
Access Fee	Sun, Jan 22 2023	Sun, May 19 2024	Not Renewable	N/A
Shop Tools	Sun, Jan 1 2023	Permanent	Not Renewable	N/A
Lab Orientation	Sun, Jan 1 2023	Tue, Dec 30 3000	Not Renewable	N/A

Conclusions/action items:

The screenshot above displays my completed D+I Lab Training as of 3/5/26.



3/8/26 Spring 2026 Training-Bloodborne Pathogens

SIERRA LOOSEN - Mar 09, 2026, 9:56 AM CDT

Title: Bloodborne Pathogens Training-Training throughout the curriculum

Date: 3/8/26

Content by: Sierra

Present: N/A

Goals: Complete training throughout the curriculum for this semester

Content:



This certifies that Sierra Loosen has completed training for the following course(s):

Course	Assignment	Completion	Expiration
2025-2026 HIPAA Privacy & Security Training	2025-2026 HIPAA Privacy & Security Training	10/23/2025	
Biosafety 102: Bloodborne Pathogens for Laboratory and Research	Biosafety 102: Bloodborne Pathogens Safety in Research Quiz 2026	3/8/2026	3/8/2027
Biosafety Required Training	Biosafety Required Training Quiz 2024	10/14/2024	10/14/2029
Chemical Safety: The OSHA Lab Standard	Final Quiz	10/14/2024	
UW Human Subjects Protections Course	Basic/Refresher Course - Human Subjects Research	10/24/2025	10/24/2028

Data Last Imported: 03/09/2026 09:26 AM

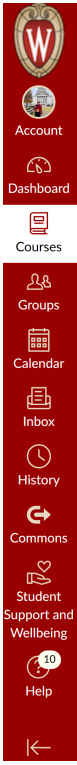

- Ongoing
- Home
- Grades 1
- Course Analytics
- Kaltura Gallery
- Library Resources
- Gradescope

Thank You

Thank you for completing Biosafety 102: Bloodborne Pathogens for Lab and Research Training course.

This training must be renewed annually.

A certificate for this training is not issued by the Office of Biological Safety. To obtain a printable record of this training please do one of the following:

1. Current Bio-ARROW Protocol users: Go to your lab's protocol in Bio-ARROW and view the Training Snapshot (for current Bio-ARROW protocol users only; allow up to 3 days for training record to show most recent updates)

OR

2. Use the [Training Record Lookup Tool](#) to look up your name and print the resulting list of completed trainings (allow up to 5 days for your training record to show the most recent updates)

Questions about Biosafety training or about your Biosafety protocol, please contact our office at biosafety@fpm.wisc.edu

For additional information on the Bloodborne Pathogens Program (BBP) please visit our web pages for <https://ehs.wisc.edu/bloodborne-pathogens/>

[← Previous](#)

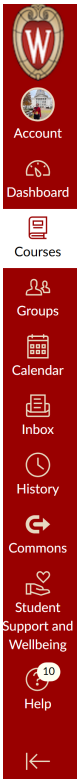

- Ongoing
- Home
- Grades 1
- Course Analytics
- Kaltura Gallery
- Library Resources
- Gradescope

Biosafety 102: Bloodborne Pathogens Safety in Research Quiz 2026

Due No due date Points 10 Questions 10
Available Jan 27 at 12am - Mar 1, 2027 at 11:59pm Time Limit None
Allowed Attempts Unlimited

Last Attempt Details:	
Time:	4 minutes
Current Score:	10 out of 10
Kept Score:	10 out of 10

Unlimited Attempts
[Take the Quiz Again](#)
(Will keep the latest of all your scores)

Instructions

****This quiz has undergone administrative updates as of January 27th, 2026. If you have already completed this course in the last year you do not need to take any other steps.****

If you have not yet completed your BBP annual training for 2026:

- To complete this training, you must pass the quiz with a score of 7 out of 10 questions correct (70%)
- You may take the quiz more than once in order to achieve a passing score.

[Take the Quiz Again](#)

Attempt History

	Attempt	Time	Score
LATEST	Attempt 1	4 minutes	10 out of 10

Score for this attempt: 10 out of 10
Submitted Mar 8 at 7:24pm

Conclusions/action items:

I was able to complete my training about bloodborne pathogens. I now know what bloodborne pathogens are and how they can be contracted. I also know how to prevent them from occurring when working with human or animal tissues.



1/28/26 Lecture Notes - Library Session 1

SIERRA LOOSEN - Jan 28, 2026, 1:56 PM CST

Title: Library Session1: Article searching, source evaluation and citation management

Date: 1/28/26

Content by: Sierra

Present: BME 301 Lecture

Goals: Learn from UW library staff how to effectively find quality sources while researching for our projects

Content:

- Online search engines
 - index information gathered from the internet by crawlers, they do not directly include informational content
 - produce a results list based on your input
- LLM Chatbots
 - trained on internet data
 - produce text based on your input
- AI chatbots
 - are predictive text generators, not search engines
 - do not evaluate for accuracy, bias, or credibility
 - generate factually incorrect statements
 - make up "hallucinates" source
 - do not respond to prompts consistently
 - are trained on undisclosed data that
 - retain systemic biases found online
 - may not be current
- Databases
 - different databases focus on different subject matters
 - can use multiple search terms to narrow down results
 - use the filters to narrow down the results
 - look at the keywords to further narrow down results to only include results with those words
 - check the references of the article you are looking at to help find even more sources
 - once you find a good source, you can save it to a citation manager like Zotero
 - You can use Zotero to add in your citations and create the bibliography
- Resources can be found on Canvas under the library resources tab
- Evaluating sources
 - relevance: what is your source about?
 - authority: who create this?
 - quality: why was this written and how does that affect the information?
 - currency: when was this source created?
 - Read literally
- Technical reports
 - publish the results of scientific or technical research, often using federal funds
 - the research is performed and reports are produced by companies, universities and government laboratories
 - some databases include DTIC (US department of defense), NTRL (US department of commerce and more), OSTL (US department of energy)
- Additional resources
 - chat with a librarian to get questions answered quickly
 - Canvas page
 - UW libraries website

Conclusions/action items:

The UW Libraries are a ton of resources that can be used to help us research for our projects. We need to find four primary resources to add to our notebook. These sources should relate to the overall/global impact of our project as well as things like the environmental impact. The team will continue researching to better understand the scope of our project.



2/4/26 Lecture Notes-Peer Resume Reviews

SIERRA LOOSEN - Feb 04, 2026, 2:01 PM CST

Title: Lecture Notes-Peer Resume Reviews

Date: 2/4/26

Content by: Sierra

Present: BME 301 Lecture

Goals: Give and receive peer feedback on cover letters and resumes

Content:

- Today we are focusing on given peers feedback on our prepared resumes and cover letters
- Important to make use of ECS resources when looking for internships/co-ops/full time jobs
- Use the job posting and rubric to evaluate
 - highlight something that was done well
 - list an area that could be improved
 - one area that could be expanded on
- Upload work done during lecture time to Canvas before leaving

Conclusions/action items:

Today in lecture, we gave our peers feedback on our resumes and cover letters. We will read through our feedback from our peers and make necessary changes to our documents. We then will submit a final copy of our resumes and cover letters for our advisors to read through and give us feedback.



2/11/26 Lecture Notes-Presentation Tips and Job Interviews

SIERRA LOOSEN - Feb 11, 2026, 2:36 PM CST

Title: Presentation Tips and Jobs Interviews

Date: 2/11/26

Content by: Sierra

Present: BME 301 Lecture

Goals: Learn about how to improve presenting and interview skills

Content:

- Job Interview Responses due at the end of today
- For next week's lecture, bring printed out copy of slideshow for in class peer review
- Preliminary Presentations are next week Friday
- Presentation tips
 - The top left bullet should line up across all slides, never have a single hanging bullet
 - Fonts should be consistent across all slides and be legible
 - Use a logical flow (not always chronological order)
 - Design ideas should be presented in the same order in all places (initial designs and then within the design matrix)
 - Keep the audience interested -- emphasize the WHY
 - Talk to your audience - not the screen
 - Hit the highlights for the design matrix, do NOT cover everything
 - Figure captions - figure number, what is it, key function/feature
 - Graphics (CAD) - use the 3D model, not the drawings, labels and scales required
 - Graphics (sketches) - remove background, clean lines, labels and scale required, type labels
 - Results - graph it, never present raw data, use appropriate font sizes, statistics
 - More resources available on the BME design website
- Interviewing Guidelines
 - bring a small portfolio (include design projects, resume, etc)
 - how to stand out among other BMEs: be specific/personal
 - design projects/leadership
 - societies/clubs
 - student assistant roles
 - highlight skills (technical and soft)

Conclusions/action items:

Preliminary presentations are next week Friday. We need to make sure to follow the guidelines for presenting and presentation slides. We also will be doing a peer review of our presentation slides during next week's lecture, so we need to ensure we print those out and bring them to lecture.



2/18/26 Lecture Notes-Preliminary Presentation Peer Review

SIERRA LOOSEN - Feb 18, 2026, 2:23 PM CST

Title: Preliminary Presentation Peer Review

Date: 2/18/26

Content by: Sierra

Present: BME 301 Lecture

Goals: Give and receive peer feedback on preliminary presentation slides

Content:

- Next week during advisor meetings will be individual conferences
- Make sure deliverables are uploaded to website and Canvas
- I was able to go through the Pavlik Kick Sensor team's slideshow and give them feedback about their presentation
 - inconsistent formatting on figure captions
 - some figure captions were missing
 - Missing titles for each design
- I will work to implement the feedback on my slides
 - fix formatting on background slide to have less words and make it into bullet points
 - get rid of hanging bullets

Conclusions/action items:

Our team got feedback from the Pavlik Kick Sensor team. This allowed us to see some mistakes with formatting and content on our slides that our group had not seen. We will work through fixing this feedback before tomorrow night which is when we plan to meet and practice presenting. We will then present on Friday to our peers.



2/25/26 Lecture Notes & Team Activity-Diversity and Inclusion in Design

SIERRA LOOSEN - Feb 25, 2026, 2:02 PM CST

Title: Diversity and Inclusion in Design

Date: 2/25/26

Content by: Sierra

Present: BME 301 Lecture

Goals: Learn about diversity and inclusion in design and how we can implement these ideas into our design

Content:

- What does diversity mean in engineering design?
 - the design is accessible for all socioeconomic levels (not so expensive that only rich people can access it)
 - the design considers the ethnicity/race of different groups of people - classic example is band aids coming in different skin tone colors
 - different skill sets within different the engineering team
 - considering people's religious beliefs or cultural practices
 - testing designs within multiple demographic groups of people to ensure everyone is included
 - ethnicity
 - socioeconomic status
 - culture
 - experiences
- What does Universal Design mean?
 - making designs accessible for all people
 - considering religion, ethnicity, socioeconomic status, etc. in your designs
 - taking into account all factors like age, disability/ability, etc
 - creating multiple designs, there isn't a one size fits all design
 - making sure the design is intuitive, people don't need a lot of background knowledge to use
 - accessible for all genders to use
 - designing broadly and inclusively, not for the 'average user'
 - "Universal design is design that's usable by all people, to the greatest extent possible, without the need for adaptation or specialized design."
- 7 principles of universal design
 - **equitable use:** the design is useful and marketable to people with diverse abilities
 - **flexibility in use:** design accommodates a wide range of individual preferences and abilities
 - **simple and intuitive use:** use of the design is easy to understand, regardless of the user's experience, knowledge, language skills, or current concentration level
 - **perceptible information:** the design communicates necessary info effectively to the user, regardless of ambient conditions or the user's sensory abilities
 - **tolerance for error:** design minimizes hazards and the adverse consequences of accidental or unintended actions
 - **low physical effort:** the design can be used efficiently and comfortably and with a minimum of fatigue

- **size and space for approach and use:** appropriate size and space is provided for approach, reach, manipulation, and use regardless of user's body size, posture, and mobility
- Ethical duty to help as many people as possible through implementing universal design

Lecture activity

- What components of our design can be improved?
 - we can 3D print in different colors
 - for a broader scope (not our project specifically) - print the rigid supports in different sizes
 - create an instruction manual for how to put the AFO on
- Which of the 7 principles are we addressing?
 - simple and intuitive use
- How can we make these improvements?
 - we want to make an instruction manual for how to put the AFO on to make it easier for users

Conclusions/action items:

We discussed how to make our design more diverse and work for a greater number of people. As a team, we discussed how we can implement the 7 principles of design. We want to make an instruction manual for how to put on the AFO, in order to implement simple and intuitive use.



3/4/26 Lecture Notes-Library Session 2

SIERRA LOOSEN - Mar 04, 2026, 1:56 PM CST

Title: Library Session 2: Patents, Standards, and Other Resources for Design

Date: 3/4/26

Content by: Sierra

Present: BME 301 Lecture

Goals: Go over patents and standards and library resources

Content:

What the libraries have:

- Full text via databases
 - ASTM standards, includes all ASTM and many ISO and IEC standards
 - ASABE - American Society for Agricultural and Biological Engineers
 - IEEE - institute for electrical and computer engineers
- Standards are freely available online to use
- Market/Industry sources
 - find information on companies, industries, consumer trends with business databases
 - specific recommendations
 - data axle reference solutions - directory information on businesses and demographic and lifestyle information on consumers
 - IBISWorld Industry Reports - market research reports on over 700 U.S. industries
 - ProQuest One Business - full-text business journals, newspapers, dissertations, and industry reports
 - Good resources to use for writing executive summary later on in semester

Patents and Prior Art-Searching

- Patent examiners evaluate applications against prior art, which includes
 - inventions disclosed in U.S. and Foreign Patents **and Patent applications**
 - inventions disclosed in publications
 - inventions currently for sale or in public use
- [Lens.org](https://lens.org) allows you to search for patents
 - to find other patents that are related to the one you are looking at, look at the "cited by" and "cites" to get related patents
 - try rearranging the words in the title of the patent to find other related sources
 - use classification codes to narrow down the search
- Patent examiners evaluate for
 - usefulness
 - novelty
 - non-obviousness
- Claims section of the patent application
 - define legally enforceable aspects of patent

- every utility patents has at least one claim
- each claim is a single sentence
 - preamble
 - transition
 - antecedent basis
- Independent claims
 - standalone
 - contain all limitations necessary to define an invention
- dependent claims
 - must refer to a previous claim
 - must further limit the claim
 - includes all limitations of claim it refers to

Conclusions/action items:

As a team, we can utilize [lens.org](https://www.patentlens.net/) to look at other designs of AFOs that are already out there. We can use this to help improve our designs. Lens has a lot of filters that can be used to either narrow or broaden the search of the patents.



3/6/26 Tong Lecture

SIERRA LOOSEN - Mar 06, 2026, 1:35 PM CST

Title: Tong Lecture

Date: 3/6/36

Content by: Sierra

Present: BME Students and Faculty

Goals: Hear from Dr. Williams about his prior experiences related to BME

Content:

In this Tong lecture, Dr. Williams talked about his path to becoming a professor and founder of numerous startup companies. He started his life on a large cattle ranch in a very rural area of South Dakota. His father didn't want him and his brother to be farmers like he was, so Dr. Williams attended South Dakota State where he got a degree in mechanical engineering. He then went to Arizona State and Michigan for further education. He helped start numerous startups and was here at UW when the BME department was first founded. Some of his messages were to work with good people, and also not be afraid of getting your hands dirty, as evidenced by him working in the operating room to help implant some of the brain devices his companies made.

Conclusions/action items:

Dr. Williams has a long and accomplished career in the field of neuroengineering. He has helped come up with devices that have bettered the lives of many people, such as helping to treat epilepsy.



3/11/26 Lecture Notes-Protocol Development

SIERRA LOOSEN - Mar 11, 2026, 1:51 PM CDT

Title: Lecture Notes-Protocol Development

Date: 3/11/26

Content by: Sierra

Present: BME 301 Lecture

Goals: Learn how to develop an effective protocol

Content:

- Low fidelity prototyping is important
 - start early
 - test individual pieces
 - documentation is still required
 - find materials in 1080 closet
- Preliminary Testing/Analysis
 - circuit diagrams and circuit testing
 - Fittings (connection points) - how are pieces being connected together
 - simple calculations
 - Free body diagrams
 - mechanics of materials
- Planning general concepts for fab and testing
 - materials - detailed list = match material expense table + more
 - name of the material
 - concentration, amount or starting dimensions
 - manufacturer and part number
 - purpose of the material
 - list of equipment needed (manufacturer and model number if known)
 - include references to papers or research in other parts of the notebook
 - methods - step by step plan - list
 - mix - for how long and with what vigor, etc.
 - cut - with what tool and what size, etc.
 - should be repeatable by unfamiliar reader
- 3D printing
 - materials
 - manufacturer and model of the printer
 - filament material, diameter and model number
 - methods - printer settings
 - layer thickness
 - infill, speed, etc.
 - support type and style
 - gCode file
- manufacturing
 - consider throughout the process

- consider throughout the process
- cannot manufacture everything you can 3D print
- common methods
 - molding - blow, injection, extrusion, rotational, thermoforming
 - machining/subtractive manufacturing - mill, lathe, waterjet
 - joining - welding, soldering, screwing, riveting, adhesives
- Seek professional advice
 - design and innovation labs
 - experts in the field - BME faculty
- Fabrication plans
 - team name, team members, project title, timeline, materials and costs tables
 - Fabrication details
 - 1. name of fabrication step/portion of prototype, date to be completed, team members fabricating, detailed sketch of portion of prototype being fabricated include dimensions, detailed bullet points
 - 2. " "
 - 3. " "
- Testing plans
 - think about statistics before you start
 - what controls are needed
 - reference and discuss the PDS criterion being tested
 - testing plan should match fabrication plan - each component needs to be tested

Conclusions/action items:

Fabrication and testing protocols need to be detailed and specific, but concise. It should also be detailed enough so that someone that is unfamiliar with the project can be replicated. The team will begin writing detailed fabrication and testing protocols.



3/18/26 Lecture Notes-Brevity in Communication

SIERRA LOOSEN - Mar 18, 2026, 1:52 PM CDT

Title: Brevity in Communication

Date: 3/18/26

Content by: Sierra

Present: BME 301 Lecture

Goals: Learn about brevity in communication

Content:

Elevator pitches

- succinctly and effectively communicate your ideas
- seize opportunities
- use an 'elevator ride' to pitch = short
- goal
 - capture attention
 - generate interest
 - leave a memorable impression
 - hopefully come away with a win
- know your audience - tailor your pitch to the interests and needs of your audience
- practice, practice, practice - rehearse your pitch until it flows naturally and confidently
- be authentic - let your passion and enthusiasm shine through
- keep it simple - avoid jargon and technical language that may confuse your audience
- adapt and iterate - be open to feedback
- general structure
 - introduction - can do first, introduce yourself and the project title
 - attention grabber - start with a hook to immediately engage your audience
 - value proposition - clearly articulate what you offer and the problem you solve
 - benefits - unique features and benefits of your product
 - call to action - end with a clear call to action
- Dos
 - maintain eye contact and exude confidence
 - keep it concise and focused
 - tailor your pitch to different audience
- Don'ts
 - overwhelm with unnecessary details
 - don't forget to listen and engage with your audience
 - don't sound rehearsed or robotic

Executive Summary

- essentially an elevator pitch put into a one page document
 - provides a concise overview of a longer document

- captures attention and conveys key information
- enables quick understanding and informed decision-making
- Introduction
- problem statement
- solution
- benefits
- recommendations
- Know your audience
- focus on the essentials
- use clear and concise language
- highlight key points
- maintain professionalism

Abstract

- provides a clear, concise, and specific summary of your work
- helps readers decide if they want to read the full paper
- typically 150-300 words
- write it last
- structure
 - background/context
 - objective
 - methods
 - results and analysis
 - discussion/conclusion

Reports

- write concisely
- eliminate extraneous text
 - do not explain the obvious
 - only provide details required to reproduce final design/testing
 - remove redundant parts (end result, important essentials, basic fundamentals)
- Avoid conversational text
- Spell out acronyms once when first introduced
- remove redundancies
- do not include raw data
- proofread thoroughly (entire document)

Conclusions/action items:

Overall, it is important to be brief and concise when writing. The writing should get the point across, but yet be short and not use unnecessary language. The executive summary is due the week after spring break.



3/25/26 Lecture Notes-Ethics in Engineering

SIERRA LOOSEN - Mar 25, 2026, 2:09 PM CDT

Title: Lecture Notes-Ethics in Engineering

Date: 3/25/26

Content by: Sierra

Present: BME 301 Lecture

Goals: Learn about ethics in engineering

Content:

How do you define ethics?

- Where do ethics come from?
 - ethics can come from how you were raised and your personal background, your own research or personal experiences, religion,
- Is there a difference between "personal" ethics and "professional" ethics?
 - professional ethics can differ from personal ethics since you personally might have different ethical beliefs than the company you work for, the professional ethics are typically decided by an overarching group or organization such as the Biomedical Engineering Society

Ethical problem-solving is similar to the design process

- establish the ethical dilemma
- understand the problem
- generate solutions
- evaluate solutions
- develop, design, test

Ethical Decision-Making Process

- **Awareness:** understand when you're facing a problem with ethical dimensions
- **Stakeholders:** imagine their needs; put yourself in their position
- **Options:** generate a range of possible actions
- **Test**

Analysis of options

- harm test
- publicity test
- reversibility test
- universality test
- respect for persons test
- utilitarian test
- social justice test

Case study

1. **The Guidant VPs:** Most of the VP's at Guidant are very much against reporting the data to the FDA. (a) How might they continue to justify their case? (b) What would be the moral foundations of their perspective?

1. They could argue that they need to not report the data to the FDA since they are still helping a large number of people where the surgery was successful. They could also say if they report these findings, it reduces the marketability of their product and decrease the amount of people who are willing to get the product. The moral foundations is that if they completely pull the product from the market, then no one will be helped at all.

2. **Patients and doctors:** Think about the position of those directly impacted: primarily patients who might be candidates for this surgery, and the doctors who use the device: (a) what arguments would those people want to ensure are considered by both the VPs and the design engineers about whether to report or not report the complications data? (b) What might be the ethical foundations of their perspective?

1. The patients are the ones who are directly being affected by this data and complications not being reported and could quite literally die from this. The doctors are also responsible for ensuring the safety of the patients, so they would argue that they need to know the effects that could possibly alter the lives of their patients. Patients should be informed about all the information so that they can make an informed decision about whether to get the procedure or not.

3. **The design engineers:** (a) What else can they say or do? (b) What arguments can they try to make, and to whom?

1. They could directly contact the FDA to report what is going on. They could potentially say something anonymously to prevent their individual reputations from being affected.

4. **The design engineers:** What options do they have? Generate a list of possible options (a minimum of 3 from the perspective of the design engineers), describe how each stakeholder is affected, then analyze them using the BME Code of Ethics (<https://www.bmes.org/2025/cmbconference/codeofconduct>) and a couple of tests from the [ethical decision-making system](#). Explain in detail the best option you would consider trying to act on.

1. Change the design of the product-benefits the patients and doctors since the product is no longer affecting the patient's arteries

Some ethical considerations of our project is that we are working with a minor, so we need to keep her parents involved in the process. We will communicate with both the patient as well as her parents so that they know what we are doing with the project. We were given permission by her parents to have direct communication with Maggie, but our main communication has been with her mom.

Conclusions/action items:

There are a lot of ethical considerations to consider in the engineering design process. We can apply these principles to our design project.



4/8/26 Lecture Notes-Engineering Judgment

SIERRA LOOSEN - Apr 08, 2026, 2:00 PM CDT

Title: Lecture Notes-Engineering Judgment

Date: 4/8/26

Content by: Sierra

Present: 301 Lecture

Goals: Learn about engineering judgment

Content:

Engineering judgment - the process of making informed decisions, often in situations where there isn't a clear cut answer or a specific code or standard to follow, by weighing available information, experience, and principles to arrive at a reasonable solution.

In engineering judgment, you can make some assumptions or approximations.

ABET outcome 6: an ability to develop and conduct appropriate experimentation, analyze and interpret data, and use engineering judgment to draw conclusions.

How do you learn engineering judgment?

- real world engineering problems
- open ending problems
- teamwork and collaboration with others
- critical thinking-evaluate solutions, testing/analysis
- communication-all forms
- handling uncertainty, including incomplete information and changing conditions

Three domains of the model

- Attitudes - what you feel and believe about a specific issue
- behaviors - how you demonstrate and act upon your knowledge and attitudes while addressing a specific issue
- cognitive - what you know about, and are able to do, to address a specific issue

We then completed an activity where we read over all the criteria in the model, and thought about how clear or applicable each criteria are.

Conclusions/action items:

This lecture focused on engineering judgment. We looked at the model that was developed with another professor that has three main categories: attitudes, behaviors, and cognitive. As a team, we thought about how these criteria apply to our projects and how the model could be made more clear.

SIERRA LOOSEN - Apr 08, 2026, 2:01 PM CDT





[Download](#)

Handout_for_BME_courses__Engineering_Judgement_Activity.xlsx (10.2 kB)



4/15/26 Lectures Notes-Poster Presentations

SIERRA LOOSEN - Apr 15, 2026, 1:48 PM CDT

Title: Poster Presentations

Date: 4/15/26

Content by: Sierra

Present: BME 301 Lecture

Goals: Learn how to make an effective poster and give a good poster presentation

Content:

- What makes a good poster
 - no hanging bullets
 - legible font sizes (not too small)
 - no big paragraphs of text, make it into bullets
 - figure captions and titles
 - info should have a logical flow
 - no raw data
 - important/relevant images
- include relevant and correct contact info
- descriptive but succinct title and subtitles
- have a good story line
- don't show all results, show the best results
- minimize text
- lots of colorful high res pics and or graphics to explain concepts
 - should be relevant
- captions - all figures and graphics must have captions
 - title, description, citation
- must be able to read text from 3 feet away except references and acknowledgements
- make sure everything is high resolution
- handouts - especially at conferences
 - business cards
 - copies of poster
 - surveys
- Have several other people proofread
 - general feedback on appearance and content

Conclusions/action items:

Next week, each person needs to bring a printed out copy of our poster to receive peer feedback. Our goal is have our poster done by Friday so that we can have Sam look at it and give us feedback.



4/22/26 Lecture Notes-Peer Poster Review

SIERRA LOOSEN - Apr 22, 2026, 3:26 PM CDT

Title: Peer Poster Review

Date: 4/22/26

Content by: Sierra

Present: BME 301 Lecture

Goals: Give and get peer review on final poster

Content:

Today we traded posters with another group to give and receive peer feedback on our final poster. We are going to implement the feedback on our final poster before printing it later today. Most of the feedback we received was regarding format issues. Peers felt that we had a lot of white space on the poster, and that some of the labels on our graphs were too small. We fixed these issues.

Conclusions/action items:

The team looked through all of the feedback we got on our final poster and implemented necessary changes. We plan to meet tonight to practice for the poster presentation and judging. We are hoping to get our poster ordered for printing by tonight.



1/30/26 BSAC Meeting

SIERRA LOOSEN - Jan 30, 2026, 11:37 AM CST

Title: BSAC Meeting

Date: 1/30/26

Content by: Sierra

Present: BSAC

Goals: Talk with other BSAC members about how projects are going so far

Content:

- Training throughout the curriculum
 - can look at spreadsheet for a list of approved trainings
 - can submit the form to suggest a new training be added to the list
- We did introductions in small groups and discussed what our projects are
- Discussed how projects are going and shared what we learned from last semester's projects
- Make sure to have good communication with your clients
- Share what was talked about in BSAC with the rest of the team so that all BME students are getting this info

Conclusions/action items:

BSAC talked about how projects are going. We also shared advice for each other. We should make sure to share the info that we talked about with the rest of our team, especially the info about the training throughout the curriculum.

 **2/6/26 BSAC Executive Meeting**

SIERRA LOOSEN - Feb 06, 2026, 12:04 PM CST

Title: BSAC Executive Meeting

Date: 2/6/26

Content by: Sierra

Present: BSAC Executive Committee

Goals: Come up with questions for next week's BSAC meeting with faculty

Content:

- Training throughout the curriculum
 - assignment will be posted to Canvas soon to submit proof of training
 - form should be completed to submit new trainings to get approved
- 201s felt like the beginning of their lab was just a repeat of their lecture and was unnecessary
- Would be nice to have a rubric/list of assignments that need to be in 201 notebooks for each notebook check
- Lecture for 200s?
 - juniors can't teach everything
 - Add CAD lecture
 - technical writing and presentation skills
- Discussion topics for future meetings
 - BME 200 lecture
 - Clarification for 402 preliminary presentations - better communication in terms of the formality
 - BME specific intro class? to not be combined with civil and geological engineering
 - Introducing the BME tracks earlier than 201
 - Advisors giving better feedback on reports/presentations, give feedback in person to make it more clear

Conclusions/action items:

The BSAC executive committee discussed areas that we feel need current improvement in BME. This included the potential of adding a lecture to BME 200, as well as creating a BME specific intro course rather than being combined with civil, environmental and geological engineering students. Next week, the general BSAC committee will meet with faculty to discuss current happenings in BME.



2/13/26 BSAC Meeting with Faculty

SIERRA LOOSEN - Feb 13, 2026, 11:46 AM CST

Title: BSAC Meeting with Faculty

Date: 2/13/26

Content by: Sierra

Present: BSAC and faculty

Goals: Discuss current topics related to BME projects and ideas for changes in the BME curriculum

Content:

- Cannot swap BME 200 and 201 due to the mentorship emphasis and difficulties for students admitted in January
- BME 201 rubric notebook checks - students need to documenting the design project should be emphasized more than checking off the rubric
- BME 200 lecture would be helpful
 - introduce concepts normally taught in 201 in 200 lecture
 - this would allow more time to focus on the actual project in 201 than learning the skills of building circuits, using SolidWorks, etc.
- The general consensus seems that there should be some sort of supplemental material/online lectures implemented into BME 200 to provide students with more introductory information to the tracks, etc.

Conclusions/action items:

The conversation around a BME 200 lecture will continue. Next week the executive committee will meet to come up with questions for the general BSAC meeting the week after.



2/20/26 BSAC Executive Meeting

SIERRA LOOSEN - Feb 20, 2026, 11:28 AM CST

Title: BSAC Executive Meeting

Date: 2/20/26

Content by: Sierra

Present: BSAC Executive Committee

Goals: Discuss BME 200 lecture topics

Content:

- Likely won't be making a BME specific intro course to replace 170, formerly was 160 with all majors but the funding model changed
- BME 200 Lecture topics
 - content moved from BME 201
 - notebook introductions
 - intro principles of electronics/other technical content (SolidWorks)
 - track reflections and general track introduction
 - advising for courses/degree planning
 - resume/career services
 - introduction to industry and internship search
 - introduction to research labs/searching for research
 - roadmap lecture for BME 200 and the rest of BME curriculum
 - online set of lectures, dependent on projects
- BME 201 Lecture thoughts
 - split into two lecture sections
 - have two lectures, friday and monday
 - make it a power lecture

Conclusions/action items:

Next week, these topics will be discussed with the entire BSAC next week.



2/27/26 BSAC Meeting

SIERRA LOOSEN - Feb 27, 2026, 11:25 AM CST

Title: BSAC Meeting

Date: 2/27/26

Content by: Sierra

Present: BSAC

Goals: Talk about current topics in BME

Content:

- Talked through potential BME 200 lecture topics
 - notebooks
 - introductory principles of electronics/other technical content
 - track reflections and general track introduction - for ALL tracks
 - resume review/career advising
 - introduction to industry and internship search
 - technical writing
 - online set of lectures
- Talked about a change in 201 lecture structure
- How did 301 presentations and preliminary reports go
- How were feedback fruits

Conclusions/action items:

The BSAC talked about implementing a lecture for BME 200. This could alleviate some of the confusion students feel during the electronics units in 201. We also talked about how our preliminary presentations and reports went for 301.



3/6/26 BSAC Executive Meeting

SIERRA LOOSEN - Mar 06, 2026, 11:29 AM CST

Title: BSAC Executive Meeting

Date: 3/6/26

Content by: Sierra

Present: BSAC Executive Committee

Goals: Come up with topics for next week's meeting with faculty

Content:

- Training throughout the curriculum reminder - due soon
- Talk about how the 402s and 201s are doing on their projects
 - how was their electronics report, and sample holder fabrication in 201
 - submitting to a journal and invention disclosure in 402
- Executive summary walkthrough and Tong Awards
- Show and tell walkthrough
- General consensus is that BME 201 lecture should be a power lecture or have TA/SA office hours right after
- Talk about upcoming course selection

Conclusions/action items:

Next week, these topics will be discussed during the BSAC meeting with Faculty. I will remind my team that the training throughout the curriculum is due on Friday the 20th.



3/13/26 BSAC Meeting with Faculty

SIERRA LOOSEN - Mar 13, 2026, 11:46 AM CDT

Title: BSAC Meeting with Faculty

Date: 3/13/26

Content by: Sierra

Present: BSAC and Faculty

Goals: Discuss current topics in BME with faculty

Content:

- Training throughout the curriculum is due next week 3/20 at midnight
- Show and tell is next week for 301
 - 402s will walk around and give advice based on their expertise
 - 301s submit call to action next week Wednesday
- General consensus is that BME 201 should be a power lecture to allow more time for students to finish their problems/work through the pre lab
- Students had mixed opinions on the sample holder fabrication consultations
 - some found it really helpful
 - others felt that they weren't very impactful
 - depends on who they had the consultation with
- Students love the BME spreadsheet of future course offerings and use that as well as DARs/degree planner on course search and enroll and plan out future semesters
- For show and tell - keep a list of questions that we want to ask 402s to get specific advice, talk about our main problem and why it hasn't worked to get advice from, 402s on that specific aspect
 - don't treat it like a formal presentation, it can be a more collaborative/conversational process

Conclusions/action items:

Training throughout the curriculum is due for our team next week Friday at midnight. We should prepare a list of questions to ask the 402s to make the most out of the experience. Don't focus too much on the background during the elevator pitch, but get to the point and what is going wrong to get the best advice.



4/10/26 BSAC Meeting with Faculty

SIERRA LOOSEN - Apr 10, 2026, 11:33 AM CDT

Title: BSAC Meeting with Faculty

Date: 4/10/26

Content by: Sierra

Present: BSAC and Faculty

Goals: Talk about end of the semester design project topics with faculty

Content:

- People liked the format of show and tell and getting feedback from the 402s
- Two weeks left before poster session
- Course enrollment questions
- Takeaways from BSAC this semester
 - good progress towards improving 201 lecture and maybe implementing a 200 lecture
- How could show and tell format for 301/402 be improved to ensure that people are actually moving from group to group rather than staying at one group the whole time, or going to every single group and not actually offering good advice

Conclusions/action items:

This was the last BSAC meeting of the semester. This semester, some of the main topics we focused on this semester included brainstorming how the lectures and labs for 201 could be improved. We also thought about how a 200 could be implemented and how that would be beneficial.



2/18/26 Individual Preliminary Presentation Work

SIERRA LOOSEN - Feb 18, 2026, 12:39 PM CST

Title: Individual Preliminary Presentation Work

Date: 2/18/26

Content by: Sierra

Present: N/A

Goals: Complete assigned section of preliminary presentation slides

Content:

- I was able to complete my assigned slides for the preliminary presentation, which included
 - Intro slides with client and patient background info, as well information about FSHD
 - Slide with problem statement on it
- I also went through the entire presentation to fix formatting
 - made sure all fonts were the same style and color
 - fixed figure caption numbering
 - fixed reference numbering

Conclusions/action items:

Our team will be getting feedback from our peers on our presentation slides during lecture today. We will then go through our presentation and implement that feedback before tomorrow night, which is when we are meeting to practice our presentation. The team will then present to our advisor and peers on Friday.



2/19/26 Individual Preliminary Presentation Work

SIERRA LOOSEN - Feb 19, 2026, 12:30 PM CST

Title: Individual Preliminary Presentation Work

Date: 2/19/26

Content by: Sierra

Present: N/A

Goals: Implement feedback from peers to fix slideshow

Content:

I went through our slideshow and implemented some of the feedback from our peers that we got during lecture

- Fixed single hanging bullets
- Fixed intro slide to have bullet points to make it easier for viewers to read
- Asked Sam about problem statement slide
 - Kept it as the full problem statement in paragraph form
 - Bolded important parts (Dr. P gave this advice)
 - Verbally, I will hit on those bolded important parts during the presentation
- We fixed the way the design matrices were on the slides to make it visually more appealing

Conclusions/action items:

The team went through the presentation and implemented the feedback we received from our peers and TA. Our team is meeting tonight to finalize the presentation slides and practice presenting. Tomorrow we are presenting to our advisors, TAs, and peers. We will also begin working on the preliminary report.



2/22/26 Individual Preliminary Report Work

SIERRA LOOSEN - Feb 22, 2026, 7:00 PM CST

Title: Individual Preliminary Report Work

Date: 2/22/26

Content by: Sierra

Present: N/A

Goals: Begin working on assigned sections of the preliminary report

Content:

I am focusing on updating the first few sections of the report, including introduction, motivation, global impact, competing designs, problem statement, background and client info. I am also adding in more information about the work that was completed in previous semesters to give more context as to where we are at on the project and show the evolution of the design.

Conclusions/action items:

The team is aiming to have the report done by Tuesday night. We will then all read through it to make any necessary changes. The team will then turn the report in by Wednesday at midnight.



2/24/26 Individual Preliminary Report Work

SIERRA LOOSEN - Feb 24, 2026, 3:38 PM CST

Title: Individual Preliminary Report Work

Date: 2/24/26

Content by: Sierra

Present: N/A

Goals: Complete updates on the PDS

Content:

I went through our PDS and implemented the feedback from Sam. This mostly involved adding in more specific numbers or ranges of values for a few sections. I also then went through and renumbered all of the references since some additional research was required to add in these numbers. I then pasted the PDS into the report as an appendix.

Conclusions/action items:

The PDS has been updated with feedback from our advisors. The team will now finish working on the preliminary report and format it tonight. The report is due tomorrow (Wednesday) at midnight.



3/7/26 MTS Testing Analysis

SIERRA LOOSEN - Mar 11, 2026, 2:58 PM CDT

Title: MTS Testing Analysis

Date: 3/7/26

Content by: Sierra

Present: N/A

Goals: Finish analysis of MTS testing data

Content:

Today I was able to complete the parsing of the MTS data. Alex collected data for three different materials, and there was three trials for each material. I calculated the stress and strain throughout each trial based on the thickness, width, and gauge that Alex recorded during testing. I then graphed stress strain curves. I put the three trials for elastic polyester on one plot, the three trials for ballistic nylon in another plot, and the three trials for TPU in a third plot. I also created a plot that had each of the 9 trials on the same graph, and color coated them based on material type to be able to compare the three materials. These graphs can be found in the experimentation folder under testing and analysis.

Conclusions/action items:

From this analysis, it shows that TPU has the highest Young's Modulus. However, the data may not be completely reliable as Alex noted the materials were slipping out of the grips during MTS testing. The team also still wants the dorsiflexion strap to have some elastic characteristics, which TPU lacks, which is why we are moving forward with the elastic polyester dorsiflexion strap. The length of this strap however, will be shortened from previous prototypes.



3/10/26 Team AFO Fabrication

SIERRA LOOSEN - Mar 11, 2026, 3:06 PM CDT

Title: Team AFP Fabrication

Date: 3/10/26

Content by: Sierra

Present: Sierra, Alex, Avery, Kalob

Goals: Begin fabrication of the new AFO prototype

Content:

Today, the team began fabrication of the new AFO. First, myself and Avery acquired all of the necessary materials in the Makerspace to prepare for fabrication. This included buying superglue, gathering scrap cardboard, a utility knife, an X-Acto knife, and a cutting mat. We also grabbed the inversion/eversion supports and cleaned off the excess material that had been 3D printed on them. Avery and I then cut out 4 pieces of the mesh padding in the shape of the hard supports. At this point, I had to leave to go to class but the rest of the team worked on sewing the mesh pieces together by hand since the sewing machine wasn't cooperating with our materials. Avery and Kalob focused on sewing the back straps together and then attaching them to the brace. Alex worked on sewing the dorsiflexion strap and velcro. I returned from class and helped plan out the future fabrication steps and helped clean up our workspace.

Conclusions/action items:

A large portion of the AFO fabrication was completed today. The dorsiflexion strap needs to be recut to an appropriate length, as it was accidentally cut too short. The team will be meeting tomorrow morning to work on finishing the dorsiflexion strap, as well as using some spare materials that were found to fabricate the front sock like portion that will attach to the dorsiflexion strap to hold it in place and avoid slippage.



3/12/26 AFO Fabrication 2

SIERRA LOOSEN - Mar 12, 2026, 1:01 PM CDT

Title: AFO Fabrication 2

Date: 3/12/26

Content by: Sierra

Present: Sierra and Alex

Goals: Keep working on AFO fabrication

Content:

Today, myself and Alex focused on finishing up the dorsiflexion strap and adding on the velcro to the AFO. I helped sew the dorsiflexion strap together at the two ends, and then Alex sewed the two portions together length wise. The strap was shortened to be 18 inches long (36 inches total since we looped it back on itself to be double the thickness). Alex sewed velcro pieces on to the front straps and also applied some super glue to hold the corners down better. Alex then worked on sewing the dorsiflexion onto the rest of the AFO.

Conclusions/action items:

We are almost done with fabrication of the AFO. We are still contemplating the idea of the toe sock attached to the dorsiflexion strap. We have some material we could use, but we also are considering buying a sock and just cutting the toe part off to attach to the dorsiflexion strap.



3/12/26 Testing Protocol Brainstorming

SIERRA LOOSEN - Mar 13, 2026, 12:32 PM CDT

Title: Testing Protocol Brainstorming

Date: 3/12/26

Content by: Sierra

Present: N/A

Goals: Brainstorm how we can implement the content from lecture into our testing plans

Content:

In lecture this week, we learned about how to create an effective protocol. Not only do the materials need to be detailed, but also the equipment that will be used. We will need to include the specific manufacturer or part number of any equipment we use, such as from the MTS machines or force plate technology. The methods also need to be extremely detailed. Maggie will essentially be completing the same testing protocol as she did last semester. However, last semester the testing took place in Madison with Team AFO present. This semester the plan is to have Maggie complete this testing at the University of Michigan with the help of Avery's friend and some people he knows. This means that Team AFO will not be present to explicitly direct Maggie and collect the data. Our testing protocol will have to be extremely precise and descriptive so that those who are helping us collect data during testing know exactly what we need them to do, even though they aren't as familiar with the project. The main rule of creating a protocol is that it needs to be repeatable by an unfamiliar reader, which is precisely what will be happening when Maggie tests the new AFO at University of Michigan.

Conclusions/action items:

The main rule of creating a protocol is that it needs to be repeatable by an unfamiliar reader, which is precisely what will be happening when Maggie tests the new AFO at University of Michigan. We need to write a protocol that is specific with materials, equipment, and units of measure. We also need to be very specific about what Maggie needs to be doing in each trial of testing (wearing the AFO vs. not, standing on two feet or one foot, the speed at which she is walking across the force plates, etc.).



3/17/26 Work on Fabrication Protocol

SIERRA LOOSEN - Mar 19, 2026, 9:42 AM CDT

Title: Work on Fabrication Protocol

Date: 3/19/26

Content by: Sierra

Present: N/A

Goals: Work on the testing protocol to be submitted for feedback

Content:

I was able to work on a specific section of our fabrication protocol, which was describing how we fabricated the two back straps of the brace. Although I didn't specifically fabricate this part, I used notes from Alex's notebook entry to write out what was done. This process involved measuring out two pieces of ballistic nylon that were 1 inch wide by 6 inches long. Then we had to slide one piece of ballistic nylon through the upper slots on the posterior sides of each CF-PLA pieces. Then we put the other piece of ballistic nylon through the inferior slots on the posterior side of the CF-PLA pieces. This should be put on around the mold of the patient's foot, and the ballistic nylon straps should be adjusted so that the medial and lateral CF-PLA pieces are securely snug on the foot. The ballistic nylon should then be looped through on each end (x4) and hand sewed to itself. These straps won't be adjustable so no velcro will be added to these straps. I also included a picture of the brace with labels on it to show where the back straps are located, and which slots they needed to be threaded through on the inversion/eversion supports.

After everyone was done with their sections, I went through the fabrication protocol and fixed the formatting to be consistent. Myself and Avery also put a table at the top of the document to show what materials and equipment are needed to fabricate the AFO, as well as the cost of any materials that need to be bought.

Conclusions/action items:

The team was able to finish the fabrication protocol of how to create the AFO. We included drawings and/or pictures in each section to help the readers visualize how to fabricate everything. Next, the team will solidify testing plans with the client (and potentially some collaborators at Michigan) and we will know what type of testing plans we need to write.



3/26/26 Executive Summary Brainstorming

SIERRA LOOSEN - Mar 26, 2026, 9:42 AM CDT

Title: Executive Summary Brainstorming

Date: 3/26/26

Content by: Sierra

Present: N/A

Goals: Brainstorm what information we should include in our Executive Summary

Content:

We have decided we will be competing for the BME Design Excellence Award as our project is tailored to one patient specifically and fits her specific dimensions. First, we should introduce FSHD and how it specifically is affecting our patient (ankle inversion and eversion, and trouble with foot dorsiflexion). I think we should highlight that the patient does currently have an AFO that was prescribed by her doctors, but due to the visual nature and bulkiness of it, she doesn't wear it. We can highlight the importance of making something that is inconspicuous and low profile and explain how this can lead to more people actually wearing their AFOs and improving their gait. We can then cover the design process, especially highlighting the scanning of her foot which was done in a previous semester and which has helped ensure that our design will fit specifically to her body shape and dimensions. We will then describe the design, mainly focusing on the two CF-PLA printed pieces, and the dorsiflexion strap. For testing, it will be done via OpenCap at the patient's home, which causes our testing to lose some validity since we are not present and are relying on cameras to capture the data for us. However, testing also included feedback from the patient directly to identify any pain points or problems with the design. Finally, we can describe the impact that our design has had on the patient in allowing her to feel more comfortable wearing an AFO in public and allowing her to continue with her horseback riding.

Conclusions/action items:



3/26/26 Makeup Show and Tell Assignment

SIERRA LOOSEN - Mar 26, 2026, 3:06 PM CDT

Title: Makeup Show and Tell Assignment

Date: 3/26/26

Content by: Sierra

Present: N/A

Goals: Complete the makeup show and tell assignment and receive feedback from 402s

Content:

I was able to complete the makeup show and tell assignment by writing out our 1 minute elevator pitch and also including a picture of the AFO. We got advice from multiple 402 students on things we are currently struggling with. Their responses are shown below along with my elevator pitch:

Inconspicuous Ankle Foot Orthosis (AFO) for teen
Link: <https://bmedesign.engr.wisc.edu/projects/s26/AFO>

Name: Sierra Loosen

Tags: Mechanics, Materials

Call to action: Our project is designing an Ankle-Foot Orthosis for a teenager in Michigan who has a type of muscular dystrophy. Because the muscles in her foot and ankle are weakened, she experiences frequent inversion and eversion of her ankle, and also has trouble with dorsiflexion of her foot. As the patient is in high school, she has emphasized that the design should be low profile to avoid unwanted attention. This project has been going on for the previous three semesters, and this semester will be the final one. Our team is looking for advice on best practices for providing a finished and aesthetically pleasing product. We are also looking for advice on how to mitigate the slippage of the dorsiflexion strap. The patient has given us feedback that after using the AFO for a period of time, it slips towards the ball of her foot and no longer provides the necessary dorsiflexion support. As shown in the picture below, the dorsiflexion strap is attached to the inversion and eversion supports on the side, and wraps around the bottom of the front of the foot. However, during use it slips backwards toward the ball of the foot.



Response 1:

BME 402 response - student name 1: Kate Hiller

When I was on this project last spring, we struggled with the dorsiflexion aspect of the project as well. I like that you have changed the design to integrate an actual strap to provide support. I wonder if there is a way to add an anchor point towards the front of the foot or around the toes so that the strap doesn't slide. Also, it could be more inconspicuous if there is a way to make the straps thinner (I can't tell from the picture what the material is now), or consider changing the material.

Response 2:

BME 402 response - student name 2: Brandon Drew

Nice job on this design. Would it be possible to adjust the straps to better fit the foot? You could add something like the end of a sock (might need a material with a little more support or stretch less) that would cover the toes and prevent the strap from slipping towards the ball of the foot. I'm assuming the patient would be able to wear a shoe over the brace, so this addition wouldn't affect the attention the brace would draw. Could you also add designs to the top of the brace to make it appear more like a sock? Not sure if this would help, but it could make it so people mistake the brace for an ordinary sock. Maybe add a flexible material over the front of the ankle to cover the exposed straps.

Response 3:

BME 402 response - student name 3: Samantha Breault

Great design! I have a similar thought to the student 2 above about adding an additional strap to the design. The strap I was considering is possibly one that goes around the big toe connected to a strap that follows the long axis of the foot over the top and then connects to the horizontal ankle strap. If additional support is needed another strap could be put around the foot on the arch section and then connected to the top strap as well. I inserted a little sketch of this idea below.



Response 4:

BME 402 response - student name 4: Yiwei Dong

This is a cool and well-motivated and user-centered project with a clear clinical need. To improve the design, I recommend focusing on stabilizing the dorsiflexion strap (e.g., better anchoring or higher-friction materials), further justifying biomechanical function through gait analysis, and refining the low-profile aesthetic for everyday wear. Additional testing and iteration based on patient feedback would also strengthen the final product. Best of luck on your design!

Conclusions/action items:

We received some helpful feedback from the seniors. A lot of the advice to fix the slipping of the dorsiflexion strap was similar to what we were already thinking about as a team. The solution is likely along the lines of adding in an additional attachment point for the dorsiflexion strap, or adding another strap all together.



4/6/26 Individual Work on Executive Summary

SIERRA LOOSEN - Apr 06, 2026, 1:42 PM CDT

Title: Individual Work on Executive Summary

Date: 4/6/26

Content by: Sierra

Present: Sierra, Avery, Alex

Goals: Work on executive summary

Content:

I was able to work on a section of the executive summary. We are competing for the design excellence award. I worked on the section describing the competing designs. I talked about that Maggie doesn't wear her prescribed AFO because it is too bulky. I then talked about the work that the previous AFO teams have done, and why those designs still needed to be improved.

Conclusions/action items:

The team completed the executive summary rough draft. We are going to submit it to get feedback from our TA. Then we will implement the feedback before we submit the final version.



4/15/26 Individual Work on Final Poster

SIERRA LOOSEN - Apr 15, 2026, 8:36 PM CDT

Title: Individual Work on Final Poster

Date: 4/15/26

Content by: Sierra

Present: N/A

Goals: Complete assigned section of final poster

Content:

Today I completed my assigned section of the final poster. This included the problem statement, background/client info, and product design specifications. I cut down the problem statement a bit in order to make it shorter and easier to read. We also decided we should bold the important words and phrases in the problem statement to help the important things stand out. I then included info about our client and patient as well as some info about FSHD. I also included some of the existing devices and a short bullet point with the main reason why our patient doesn't like those devices. This sets up the main goal for this project which was creating a new AFO design that is sleek and inconspicuous. I then took the PDS criteria from our preliminary presentation and included those on the poster as well.

Conclusions/action items:

The team plans to finish the poster by this Friday night so that we can send it to Sam and get feedback from her. We also will be doing peer poster review in lecture next week before printing the poster.



4/16/26 UMich Data Analysis Work

SIERRA LOOSEN - Apr 16, 2026, 2:55 PM CDT

Title: UMich Data Analysis Work

Date: 4/16/26

Content by: Sierra

Present: N/A

Goals: Research if there is a way to convert the qtm files into a different file type to analyze

Content:

The data files we received from the University of Michigan were all .qtm files. We asked the grad student at Michigan who is helping us with this testing how we could actually analyze the data from these files. She said that we would need to have a specific software which none of us were familiar with. This morning I did some research to see if there would be any way for us to get access to the QTM software through the CoE or convert the file to a different file type so that we could parse the data. However, I quickly found that QTM has their algorithms on lockdown and so there is no real way to convert the qtm file to a different type without the QTM software. Alex then emailed Hiva to ask if they could convert the files to .mat so that we could analyze our data in matlab.

Conclusions/action items:

We are hopeful that Hiva will be willing and able to convert the data files to .mat. We would then be able to analyze our data in matlab.



4/21/26 Individual Final Deliverables Work

SIERRA LOOSEN - Apr 23, 2026, 7:16 PM CDT

Title: Individual Final Deliverables Work

Date: 4/21/26

Content by: Sierra

Present: N/A

Goals: Work on final deliverables

Content:

This week the team is focusing on finishing all final deliverables and preparing for the poster session. I worked on completing my sections of the poster, which included problem statement, background info, and product design specifications. After everyone was done with their sections, I went through and fixed some formatting things such as making sure all text was the same size and fixing figure caption titles and numbers. I also worked on my sections of the report. I wrote the introduction, background, client info, existing devices, and product design specifications. I also completed part of the testing section about the stabilograms/balance testing since I analyzed that data in MATLAB. The team has received feedback from peers and advisors on the poster and has implemented the changes.

Conclusions/action items:

This week, the team finished the final poster. We also met a few times to go through the elevator pitch as well as the full presentation for our poster.



4/28/26 Individual Work on Final Report

SIERRA LOOSEN - Apr 28, 2026, 12:54 PM CDT

Title: Individual Work on Final Report

Date: 4/28/26

Content by: Sierra

Present: N/A

Goals: Work on final report

Content:

I worked on finishing up some sections of the final report. This included running some statistics on the stabilogram path length data. There was no statistical difference between wearing the afo and not wearing the afo with the eyes closed. However, there was a 10.8% reduction in the path length. This shows that with more trials of testing and potentially some tweaks, there could be a statistical significance. I also began working on some final formatting, such as citations and figure numbers.

Conclusions/action items:

The team will work to finish the final report tonight, so that we can fix the formatting tomorrow. We also will finish the final notebook and get that submitted.



1/28/26 Ankle foot orthosis quick search

KALOB KIMMEL - Jan 28, 2026, 2:56 PM CST

Title: AFO Research

Date: 1/28/26

Content by: Kalob

Present: Kalob

Goals: Learn twwhat AFO is.

Source:https://www.physio-pedia.com/Introduction_to_Ankle_Foot_Orthoses

Content: AFO are biomechanical devices that are used on the lower extremities to stabilize the joints. They also improve the gait and funtion of the affected extremithy. This is a broader term that is used for the treatments of dorsiflexion, planar flexion, ballence, falling risks, muscule weakness, etc. These can help with one or multiple of these weaknesses. They come in many shapes and sizes depending on the intended use. These include different materials such as plastics, carbon fiber, different types of padding, and so forth. Measurment is important in order to get correct sizes for the fitting of the device.

Conclusions/action items: Overall AFOs are like a fancy ankle brace, and I need to find out what specific types of flexion and support are needed in order to know more about the AFO we want to complete.



2/2/26 Dorsiflexion

KALOB KIMMEL - Feb 02, 2026, 8:56 AM CST

Title: Dorsiflexion Improvements

Date: 2/2/26

Content by: Kalob

Present: Kalob

Goals: learn about current methods to improve dorsiflexion gait

Source:

<https://link.springer.com/article/10.1186/1757-1146-6-46>

Content:

Stretching Interventions

- **Static Stretching:** Found to be the most consistently effective intervention. Studies report a Standardized Mean Difference (SMD) ranging from 0.70 to 1.69, indicating a large effect size for increasing range of motion (ROM).
- **Chronic vs. Acute:** Chronic stretching (performed over several weeks) shows stable gains of approximately 5.17. Even a single session of static stretching can produce immediate, though potentially transient, improvements.
- **PNF Stretching:** Proprioceptive Neuromuscular Facilitation (PNF) is also effective, with meta-analyses showing an average increase of 4.32.
- **Ballistic Stretching:** This technique generally does not show significant positive results for increasing dorsiflexion ROM compared to static or PNF methods.

Manual Therapy and Mobilization

- **Joint Mobilization :** Posterior glides of the talus (Grades III/IV) are highly effective, especially when a "joint block" or non-contractile tissue is the limiting factor.
- **Mobilization with Movement (MWM):** Combines manual gliding with active dorsiflexion. It has shown significant efficacy, particularly in athletes and those with chronic ankle instability, though some studies note that gains may be smaller in specific injured populations.
- **Manipulation:** High-velocity, low-amplitude (HVLA) thrusts have been shown to provide immediate short-term ROM increases, often superior to stretching alone in the initial post-treatment window.

Combined & Adjunct Therapies

- **Thermal Agents:** Stretching combined with ultrasound or diathermy appears more effective than stretching alone, as heat increases tissue extensibility.
- **Strength Training:** Strengthening the anterior compartment (tibialis anterior) may lead to quicker gains in active ROM compared to stretching alone, as it improves the motor control required to utilize new range.
- **Corrective Exercise Programs:** Comprehensive programs that include self-mobilization, stretching, and neuromuscular re-education (feedback during jump-landings) show promising results in reducing injury risk by maintaining ROM during dynamic tasks.

Clinical Recommendations

- **Assessment First:** Use the Weight-Bearing Lunge Test (WBLT) to determine if the restriction is "soft tissue" (calf tightness) or "joint" (capsular/bony restriction).
- **The "Dose" Matters:** For manual therapy, higher doses (for example 48 minutes over 6 sessions) yield significantly better results than shorter, infrequent applications.
- **Home Programs:** Static stretching as part of a standardized home exercise program is recommended for maintaining the gains achieved during clinical manual therapy.

Conclusions/action items: This article covered a lot of active stretches and other techniques for improving the dorsiflexion gait which is not too helpful for our project so I need to be more specific in my search to look for braces/ other passive methods to help with walking gait.

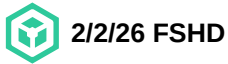
**Title: Understanding FSHD****Date:** 2/2/26**Content by:** Kalob**Present:** Kalob**Goals:** I would like to understand what FSHD is and what effects it has on the ankle specifically**Sources:**

<https://www.mda.org/disease/facioscapulohumeral-muscular-dystrophy>
<https://link.springer.com/article/10.1007/s00415-006-0230-z>

Content:**FSHD stands for Facioscapulohumeral muscular dystrophy****What is it?**

It is a genetic muscle disorder. It affects the muscles of the face, shoulder blades, and upper arms the most. Muscular dystrophy stands for muscle degeneration and it effects atrophy or the loss of muscle mass. It is the third most common muscular dystrophy with 4 out of 100,000 cases.

Symptoms:

Symptoms start before age of 20. There is loss of muscle and atrophy in the legs, around the eyes, shoulders, mouth, abdominal area, upper arms. This usually involves the asymmetric involvement of muscles. In earlier ages the cases are usually more severe. This can effect the infants hearing or vision. Some research shows that the earlier onset version correlates to larger segments of dna missing. It is most cases and most people have a normal lifespan with it. There is no current cure, and treatment is symptom management.

Cause:

The cause is a genetic flaw or mutation which leads to the inappropriate expression of the double homeobox protein 4 gene. This is on chromosome 4 in the 4q34 region. It is not a part of any gene.

Deeper dive

In this disease D4Z4 repeats on the chromosome 4q35. The full pathogenic mechanism is not understood.

Leg Involvement:

- Leg Involvement was studied on MRI by David B. Olsen et. al. as of 2006
- Cohort of 18 patients with verified FSHD
- Mean duration of symptoms experienced was 16.5 years
- The MRI used T1 - weighted axial slices and they were placed over the lower body for 4 acquisitions.
- They evaluated in 4 grades with grade 1 being normal muscle and grade 4 being similar signals to paramacular fat.
- Strength testing was done for hip flexion, extension, abduction and adduction, and knee and ankle flexion/ extension
- Testing was manual using the MRC scale. 0-5: no contraction, normal power
- Results showed evidence of lower extremity involvement in all but one subjects.
- Tibialis anterior compartment had a score of 2.3
- Medial gastrocnemius muscle had a score of 2.0
- Some of the patients had replacements of muscles such as their hamstring and gastrocnemius muscle.

Here is the data table for the study.

Mean \pm SE MRC	Mean \pm SE MRI	Spearman r	P	
Hip flexion	4.2 \pm 0.2	1.6 \pm 0.1	0.30	NS
Hip extension	4.2 \pm 0.2	2.1 \pm 0.2	0.66	<0.0
Hip abduction	4.2 \pm 0.2	1.8 \pm 0.2	0.77	<0.0
Hip adduction	4.2 \pm 0.2	1.7 \pm 0.2	0.78	<0.0
Knee flexion	4.3 \pm 0.2	1.6 \pm 0.2	0.82	<0.0
Knee extension	4.5 \pm 0.1	2.1 \pm 0.2	0.54	0.00
Ankle dorsal flexion	3.7 \pm 0.3	2.3 \pm 0.2	0.70	<0.0
Ankle plantar flexion	4.6 \pm 0.1	1.6 \pm 0.1	0.12	NS

Conclusions/action items: FSHD is a muscular disease that leads to atrophy. A high area of weakness for the disease is in the legs and ankle with prominent problems with dorsal 1 start at any time but younger onsets tend to have more severe symptoms. There is no current cure so current treatment is symptom management.



Title: "Dynamic stability during level walking and obstacle crossing in persons with facioscapulohumeral muscular dystrophy"

Date: 2/6/26

Content by: Kalob

Present: Kalob

Goals: I would like to understand more about fshd and how our project relates to it specifically

Sources: https://www.sciencedirect.com/science/article/pii/S096663621500507X?casa_token=xCOi44sscPsAAAAA.NoZsF2tdr5UVslyDIPwpd1ERyaUPkJ3tWcwnNM_fDWksfDNIMoLpghLEHBBII5CTIZ3hFe2jpQ

Content:

- **Goal:** To determine if changing the Foot Progression Angle (FPA) can reduce the Knee Adduction Moment (KAM)—a primary indicator of medial knee compartment loading—during both walking and running.
- **Participants:** The study focused on individuals diagnosed with medial knee osteoarthritis (OA), a population where reducing joint load is critical for slowing disease progression.
- **Significance:** While walking gait modifications are well-studied, this research expands the understanding to running, which involves higher impact forces.

Key Findings

- **Toe-Out Maneuver:** Significantly reduced the late-stance peak KAM during walking.
 - Had a more variable effect during running but generally helped shift the load distribution.
- **Toe-In Maneuver:**
 - Consistently reduced the first peak KAM during both walking and running.
 - This is particularly important because the first peak is typically the highest load the knee experiences during the gait cycle.
- **Walking vs. Running:** The effectiveness of FPA modification was similar in both activities, suggesting that gait retraining developed for walking can potentially be translated to higher-impact activities like running.

Clinical Implications

- **Personalized Intervention:** The "one size fits all" approach does not apply; some patients benefit more from toe-in while others benefit from toe-out depending on whether their peak pain/loading occurs early or late in the step.
- **Conservative Management:** FPA modification serves as a non-invasive, cost-effective strategy to manage knee OA symptoms and potentially delay the need for surgical intervention.
- **Kinematic Trade-offs:** The study notes that while KAM is reduced, changes in FPA may increase moments at the hip or ankle, which must be monitored by clinicians.

Summary: This study demonstrates that modifying the foot progression angle through toe-in or toe-out maneuvers effectively reduces the knee adduction moment. This does not address the dorsiflexion we are focusing on, but could be helpful with the progression of FSHD.



3/2/2026 "Steppage Gait"

KALOB KIMMEL - Apr 29, 2026, 5:31 PM CDT

Title: "Steppage Gait"

Date: 2/6/26

Content by: Kalob

Present: Kalob

Goals: Understand Gait testing

Sources: <https://www.ncbi.nlm.nih.gov/books/NBK547672/>

The review focuses on individuals with Foot Drop which is a condition that is included in muscular dystrophies.

Significance: Steppage gait is a critical clinical marker for dorsiflexor weakness. Because the foot cannot clear the ground during the swing phase, the patient must lift the hip and knee higher than normal to avoid tripping, which significantly increases the metabolic cost of walking and the risk of falls.

Key Findings

- **The Swing Phase Deficit:** The typical feature of this gait is the loss of foot clearance. Without active dorsiflexion, the foot remains in a plantarflexed (toes pointing down) position during the swing phase.
- **High Steppage Maneuver:** To compensate for the long limb, the patient exaggerates hip and knee flexion. This is often described as a marching or a horse like step.
- **Initial Contact (Foot Slap):** Instead of a controlled heel strike, the foot often lands flat or with the toes first. If the heel does strike first, the lack of eccentric control from the dorsiflexors causes the foot to slap onto the floor.

Clinical Implications

- Steppage gait is not a diagnosis itself but a symptom. It can indicate issues ranging from a simple nerve compression to complex neurological conditions like FSHD or ALS.
- The primary clinical concern is the high risk of falls. The tripping hazard caused by the inability to clear the toes makes conservative management like AFOs essential for patient safety.
- **Differentiation:** It is vital to distinguish steppage gait from other patterns like Circumduction gait (swinging the leg out to the side) or Ataxic gait (uncoordinated balance issues), as each points to a different neurological origin.

Summary: This source shows mechanics of steppage gait, which is directly caused by the loss of dorsiflexion. This is highly relevant to our project, as FSHD often manifests as foot drop as shown in our patient, making the understanding of this specific gait compensation central to how we address the progression of the disease.



2/5/26 Push Ortho AFO by Brace Lab

KALOB KIMMEL - Feb 05, 2026, 11:26 PM CST

Title: Push Ortho AFO

Date: 2/5/26

Content by: Kalob

Present: Kalob

Goals: Learn about the competing design

Source: <https://bracelab.com/push-ortho-ankle-foot-orthosis-afo.html?srsltid=AfmBOoqoaYfuHvtV-e-OxvgRIDOZBJ2ZfkLPewV8fzrl3qMXJ8Z0Fc9B>

Content:

While traditional hospital-issued AFOs often struggle with patient compliance due to bulk and rigidity, the Push Ortho AFO represents a competing "modern-minimalist" design. It targets the "closet abandonment" issue by prioritizing footwear compatibility and a natural gait cycle.

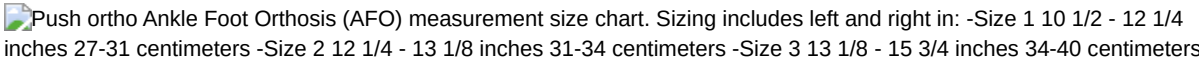
- **Design Philosophy: Modern Minimalist vs. Traditional Rigid**
 - Unlike the solid thermoplastic shells evaluated in the tertiary care study, the Push AFO uses a flexible, low-profile **composite frame** paired with a sophisticated strap system.
 - It is specifically designed to be "shoe agnostic," allowing users to wear it with a wide variety of footwear, including slippers and sandals. This directly addresses the #1 complaint of footwear restriction found in hospital studies.
 - **Dynamic Gait Control Features:**
 - **Adjustable "Dot-System" Straps:** The device utilizes a unique elastic strap system that allows users to customize the level of dorsiflexion during the swing phase, accommodating individual muscle strength.
 - **Controlled Plantar Flexion:** Instead of a hard stop at heel strike, the elastic straps provide a "braking" function, mimicking natural muscle eccentric control and preventing the "foot slap" common in rigid designs.
 - **Medial-Lateral Stability:** While the sole is flexible, the rigid composite frame wraps around the ankle to provide the lateral stability necessary to prevent inversion/eversion.
 - **Patient Experience & Satisfaction :**
 - **Comfort:** Constructed from *Sympress*[™] microfiber, the material is moisture-wicking and machine-washable, aiming to eliminate the skin irritation and "heaviness" cited as major reasons for device abandonment.
 - **Ease of Use:** It employs a numbered "dot system" on the straps to guide the patient through the donning process, reducing the cognitive and physical burden for stroke survivors or those with limited dexterity.
 - **Social & Aesthetic Integration:** Because the frame is extremely low-profile and fits inside most standard shoes, it minimizes the "aesthetic burden" and social stigma associated with bulky, visible orthoses.
 - **Competing Constraints & Contraindications:**
 - **Not for Severe Spasticity:** Unlike the solid-ankle AFOs used in tertiary care for high-tone patients, the Push AFO is contraindicated for moderate-to-severe spasticity or extreme foot deformities.
 - **Calf Muscle Dependency:** This design requires some residual control of the calf muscles to be effective during the rolling phase of the step, making it an assist rather than a total limb replacement.
-  Push ortho Ankle Foot Orthosis (AFO) measurement size chart. Sizing includes left and right in: -Size 1 10 1/2 - 12 1/4 inches 27-31 centimeters -Size 2 12 1/4 - 13 1/8 inches 31-34 centimeters -Size 3 13 1/8 - 15 3/4 inches 34-40 centimeters
- Measure

Conclusions/action items: The Push Ortho AFO is a low-profile, high-compliance alternative that uses a unique strap system to enable a natural gait and compatibility with almost any standard shoe.



2/6/26 Pro care super lite

KALOB KIMMEL - Feb 06, 2026, 12:16 AM CST

Title: Push Ortho AFO

Date: 2/6/26

Content by: Kalob

Present: Kalob

Goals: Learn about the competing design

Source: <https://enovis.com/products/procare/super-lite-afo>

Content:

The ProCare Super Lite AFO by Enovis represents injection-molded, prefabricated orthotics. While the Push AFO focuses on flexibility and straps, this design focuses on rigidity and extreme lightweight construction using traditional materials.

- **Design Philosophy: Lightweight Rigidity**
 - Constructed from a thin-walled, injection-molded polypropylene, this design is engineered to be "Super Lite" while maintaining a strictly rigid 90-degree angle.
 - Unlike the Push AFO's dynamic strap system, this is a passive-resistance device, meaning it relies on the mechanical strength of the plastic to physically hold the foot up during the swing phase of the gait.
- **Addressing Functional Constraints:**
 - **Trimable Footplate:** A key engineering feature is the extended footplate that can be trimmed with scissors to fit the user's specific shoe size, allowing for a semi-custom fit from a mass-produced product.
 - **Low-Profile Open Heel:** The "open heel" design is intended to take up less volume in the shoe, which addresses the footwear compatibility ethical concern, though it remains bulkier than a strap-based system.
 - **Heat Modifiable:** Because it is made of polypropylene, a clinician can use a heat gun to slightly adjust the shape to accommodate minor bony prominences or pressure points, improving comfort over a non-modifiable rigid brace.
- **User Experience & Compliance:**
 - **Simplicity:** The design uses a single calf strap with a hook-and-loop closure, making it one of the easiest devices to don and doff for patients with limited hand strength.
 - **Durability vs. Comfort:** While highly durable and easy to clean, the rigid plastic back can lead to "heat build-up" and perspiration, which were noted as secondary causes of abandonment in the tertiary care study.
- **Ethical & Economic Position (Cost of Access):**
 - **The Economy Choice:** This device is significantly more affordable than carbon fiber or specialized composite braces, directly addressing the **Distributive Justice** concern by providing a low-cost entry point for gait assistance.
 - **Basic Functionality:** It provides the bare minimum "medically necessary" support for foot drop, making it the design most likely to be covered by basic insurance plans.

Conclusions/action items: The ProCare Super Lite AFO provides a lightweight, rigid polypropylene solution that offers essential dorsiflexion support at a price point that facilitates broad clinical access.



3/13/26 Dynamic exoskeletal orthosis

KALOB KIMMEL - Mar 13, 2026, 12:41 PM CDT

Title: Dynamic exoskeletal orthosis

Date: 3/13/26

Content by: Kalob

Present: Kalob

Goals: Learn about the competing design

Source: [https://patents.google.com/patent/US11844714B2/en?q=\(ankle+orthotic\)&oq=ankle+orthotic](https://patents.google.com/patent/US11844714B2/en?q=(ankle+orthotic)&oq=ankle+orthotic)

Content:

The US11844714B2 patent describes a high-performance, carbon-fiber orthosis designed to restore gait for patients with severe lower-limb impairments.

- **Proximal Cuff:** A rigid cuff placed just below the knee, utilizing a patellar tendon-bearing design to offload weight from the ankle and transfer it directly to the leg. It features a unique hinge along the upper edge to allow for easier ways to put on and take off without sacrificing rigidity.
- **Posterior Strut System:** One or more carbon-fiber struts connect the proximal cuff to the footplate. These struts act as a dynamic spring.
 - **Energy Storage:** During the mid-to-late stance phase of walking (as the heel lifts), the strut bends and stores mechanical energy.
 - **Energy Return:** As the user initiates a step, the strut snaps back, providing "power" for push-off and ensuring the foot clears the ground.
- **Footplate Section:** A custom-molded base that extends to the toes. It includes "lateral wings" specifically designed to provide mediolateral stability and prevent the foot from rolling inward or outward.
- **Modularity:** The patent covers a design where the struts can be swapped out to adjust the stiffness as the patient's strength or activity level changes.

Comparison to Group Design

Our design is utilizing two medial/lateral supports with dorsiflexion straps

- **Mechanism of Action:** Patent: Uses a posterior spring compression/tension of carbon fiber to physically propel the foot.
 - **Group Design:** Uses tensioned straps to provide a "pull" for dorsiflexion acting as a suspension system.
- **Mediolateral Stability:**
 - **Patent:** Relies on a rigid, molded supramalleolar section with lateral wings. This is fixed stiff.
 - **Group Design:** Uses two dedicated vertical supports. This provides targeted bracing specifically against ankle rolling while allowing for a slimmer profile inside a shoe.
- **Offloading vs. Assistance:**
 - **Patent:** Specifically designed to offload weight from the heel and ankle joint to the knee cuff. This acts as the exoskeleton.
 - **Group Design:** focuses on alignment and lift without trying to bypass the ankle's weight-bearing role. This allows for a lower profile which leans into the inconspicuous part of the project.
- **Adaptability for Muscle Atrophy:**
 - **Patent:** Uses a rigid carbon cuff that is difficult to adjust if the leg size changes significantly due to atrophy.

- Group Design: The use of straps allows for constant cinching and adjustment, making it far more accommodating for the progressive muscle volume changes typical in FSHD patients.

Conclusions/Action Items

The US11844714B2 patent is a "heavy-duty" solution meant for high-impact activities like running. Our design better suits our client because it provides support while being adjustable and low profile.

KALOB KIMMEL - Mar 13, 2026, 12:45 PM CDT



[Download](#)

US11844714-20231219-D00000.png (2.67 kB)



3/13/26 Orthotics brace and system patent

KALOB KIMMEL - Mar 13, 2026, 12:18 PM CDT

Title: Orthotics brace and system

Date: 3/13/26

Content by: Kalob

Present: Kalob

Goals: Learn about the competing design

Source: [https://patents.google.com/patent/US11103376B1/en?q=\(ankle+orthotic\)&oq=ankle+orthotic](https://patents.google.com/patent/US11103376B1/en?q=(ankle+orthotic)&oq=ankle+orthotic)

Content:

This patent describes a orthotic device designed for joint, bone, and tissue support at the ankle. It is a multi-layered brace system consisting of an inner boot and an outer shell assembly. Unlike standard single-piece braces, this system uses a "boot-within-a-shell" approach to provide targeted compression and rigid support.

Key Components:

- **Inner Boot:** A removable, molded, lace-up component. It is designed to fit snugly against the foot and ankle to provide the primary layer of comfort and stabilization.
- **Outer Shells:** Two structural shells placed around the ankle and foot area. These are secured with straps to the inner boot.
- **Closure System:** A combination of laces for the inner boot and straps/fasteners for the outer shells to allow for adjustable tension.

Mechanical Function: The system is designed to provide targeted support areas. By adjusting the straps on the outer shell, a user or clinician can apply specific pressure or restriction to certain movements. This is particularly relevant for patients needing stabilization against lateral or medial rolling of the ankle.

Relevance to our project:

- **Dorsiflexion Support:** Given that FSHD patients often struggle with the Tibialis anterior, the rigid outer shells of this patent could potentially be configured to act as an AFO to prevent foot drop.
- **Atrophy Accommodation:** Because the system uses a lace-up inner boot and adjustable outer straps, it can be tightened to accommodate the progressive muscle atrophy
- **Bilateral/Asymmetric Stability:** The customizable nature of this brace allows for different support levels on the left vs. right leg

Conclusions/Action Items: The US11103376B1 patent offers a highly adjustable, dual-layer support system that could be used for symptom management. Its primary benefit over traditional braces is the molded inner boot, which may reduce skin irritation in patients with significant muscle loss.

KALOB KIMMEL - Mar 13, 2026, 12:45 PM CDT

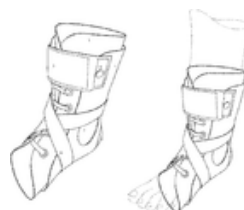

[Download](#)

US11103376-20210831-D00000.png (6.29 kB)



2/5/26 Patient Satisfaction of AFO

KALOB KIMMEL - Feb 05, 2026, 11:01 PM CST

Title: Patient Satisfaction of AFO

Date: 2/5/26

Content by: Kalob

Present: Kalob

Goals: Learn about ethics and satisfaction of AFOs

Source: <https://pmc.ncbi.nlm.nih.gov/articles/PMC12317181/>

Content:

This cross-sectional study conducted at a tertiary care hospital evaluates the effectiveness of Ankle-Foot Orthoses (AFOs) from the user's perspective. As seen in the research, there is often a disconnect between the clinical success of a brace and the patient's willingness to wear it daily.

• Compliance and Usage Patterns:

- Many patients exhibit "selective compliance," wearing the device only for specific tasks rather than the prescribed duration.
- Use typically peaks in the first few months post-prescription but tends to decline as patients encounter daily lifestyle barriers.

• Device Satisfaction Factors:

- **Comfort and Weight:** These are the most critical factors for patients; even a biomechanically perfect brace will be abandoned if it feels too heavy or causes pressure sores.
- **Ease of Use:** Difficulty with donning and doffing (putting the brace on and off) is a major deterrent, especially for patients with hemiplegia or limited dexterity.
- **Aesthetics and Footwear:** Satisfaction drops significantly when a device limits a patient's choice of shoes or is highly visible, creating a "social stigma" or "aesthetic burden."

• Service Quality Assessment:

- Patients generally report higher satisfaction with the **professional service** (the expertise of the orthotist) than with the **physical device** itself.
- Frequent follow-up appointments and clear communication during the fitting process are directly linked to better long-term outcomes.

• The "Closet Abandonment" Phenomenon:

- A significant percentage of devices end up unused ("in the closet") because the physical discomfort or inconvenience outweighs the perceived functional gain of improved gait.

After reviewing the clinical data and the practical barriers identified in the study, several strategies for improving orthotic success emerge:

• Patient-Centered Design:

- Shifting from a "prescription-only" model to "shared decision-making" where the patient's lifestyle and footwear preferences are factored into the material choice (e.g., carbon fiber vs. plastic).
- Targeting the root cause of non-use by prioritizing skin integrity and reducing the bulk of the orthosis.

• Early Intervention and Education:

- Initial trials suggest that patients who receive intensive training on how to integrate the AFO into their daily routine show higher long-term adherence.

- Providing specific footwear recommendations at the time of fitting reduces the "shoe compatibility" frustration.

- **Technological Advances (2025-2026 Trends):**

- **3D Printing:** Customized 3D-printed AFOs are beginning to show promise in reducing weight and improving the precision of the fit, directly addressing the "comfort" complaints seen in older studies.
- **Smart Sensors:** Newer research is exploring the use of integrated sensors to monitor actual wear-time data, allowing orthotists to adjust the device based on real-world usage patterns rather than patient recall.

- **Regulatory and Clinical designated outcomes:**

- The study advocates for standardized "Patient Reported Outcome Measures" (PROMs) to be used in all tertiary care settings to ensure the user's voice is part of the clinical record.
- Regulatory bodies are increasingly looking at "quality of life" metrics, not just "gait speed," as the primary measure of orthotic success.

Conclusions/action items: This study reveals that while patients generally value the professional expertise of orthotic services, they frequently abandon AFOs due to practical burdens like discomfort, excessive weight, and poor footwear compatibility.



2/5/26 Inaccessibility due to cost

KALOB KIMMEL - Feb 06, 2026, 12:02 AM CST

Title: Inaccessibility due to cost

Date: 2/5/26

Content by: Kalob

Present: Kalob

Goals: Learn about ethics of price points of disability access items

Source: <https://pmc.ncbi.nlm.nih.gov/articles/PMC12317181/>

Content:

The article from the World Institute on Disability (WID) explores the High Cost of Disability, often referred to as the Cripple Tax. This is the systemic financial burden placed on disabled individuals who must pay a premium for basic societal participation.

- **The Inaccessibility of Access:**
 - Ethical Concern: Distributive Justice.
 - The article highlights a paradox where the tools required for equal opportunity (AFOs, wheelchairs, adaptive tech) are priced as luxury items rather than fundamental rights.
 - When the "cost of access" is higher than a person's income or insurance coverage, the product—no matter how well-engineered is ethically inaccessible.
- **Poverty Traps:**
 - Ethical Concern: Non-Maleficence.
 - Disabled individuals often face hidden costs such as higher utility bills, specialized clothing, repair costs for orthotics that lead to a cycle of poverty.
 - Engineering products without considering long-term maintenance costs can inadvertently cause financial harm to the user.
- **The Burden of Medical equipment :**
 - Ethical Concern: Autonomy and Agency.
 - Insurance companies often act as gatekeepers, deciding which version of a product is necessary.
 - This creates an ethical crisis for engineers: if you design a high-functioning, low-profile brace like the Push AFO, but it is classified as not medically necessary compared to a cheaper, bulky alternative, the user's ability to choose their lifestyle is stripped away by financial barriers.
- **Market Failure in Assistive Tech:**
 - Ethical Concern: Social Equity.
 - The disability market is often seen as a niche, leading to low competition and artificially high prices for specialized hardware.
 - The article argues that access to assistive technology should be viewed as a Human Rights issue rather than a market driven consumer choice.

Conclusions/action items: The "High Cost of Disability" highlights the ethical crisis where essential assistive technologies are priced as luxuries, creating a poverty trap.



2/20/26 Working with adolescents to make medical devices

KALOB KIMMEL - Feb 20, 2026, 11:17 AM CST

Title: Medical device ethics

Date: 2/20/26

Content by: Kalob

Present: Kalob

Goals: Learn about the ethics of working with a teen to make a medical device

Source: <https://pmc.ncbi.nlm.nih.gov/articles/PMC5129186/>

Content:

- **Growth and Development:** Adolescents are not small adults. Rapid physical changes, such as bone growth and puberty, can affect the fit and function of implants over time. This creates an ethical duty for manufacturers to move beyond one size fits all designs to ensure long-term patient safety.
- **The Ethics of Data Extrapolation:** A major concern is that many pediatric devices are approved using data extrapolated from adult studies. This raises questions of scientific justice, as assuming a device will behave the same in a developing body as in an adult body can lead to unforeseen risks.
- **Weight-Based Risks & Beneficence:** Using adult-based algorithms for adolescents such as in insulin pumps can be dangerous. The article suggests it is an ethical necessity to ensure these technologies are robust enough to support the specific weight and metabolic profiles of teenagers to prevent harm like hypoglycemia.
- **Autonomy and Compliance:** As adolescents gain independence, they often manage devices with less parental oversight. The article highlights the tension between adolescent autonomy and the high rate of adverse events like eye infections from contact lenses caused by non-compliant behavior.
- **Active Lifestyles:** The high activity levels of teenagers including sports and risk-taking put unique mechanical stress on devices. Clinicians have a responsibility to be "especially vigilant" to ensure a patient's daily life doesn't compromise the device's effectiveness.

Conclusions/action items: The article argues that adolescents are a distinct population whose rapid growth and increasing autonomy create unique ethical and safety challenges in medical device design.



2/20/26 Consent and other ethical concerns

KALOB KIMMEL - Feb 20, 2026, 11:28 AM CST

Title: Consent and other ethical concerns

Date: 2/20/26

Content by: Kalob

Present: Kalob

Goals: Learn about the ethical dilemmas when working with adolescents

Source: <https://med.nyu.edu/departments-institutes/population-health/divisions-sections-centers/medical-ethics/sites/default/files/medical-ethics-teens-and-children-in-clinical-research.pdf>

Content:

Fundamental Principles of Research Ethics

- Core Objectives: Protecting participants, ensuring research serves the interests of those involved, and examining projects for ethical soundness, including risk management and informed consent.
- The Small Adult Fallacy: For decades, researchers erroneously assumed adult medication dosages could simply be adjusted based on height and weight. This is biologically inaccurate due to the unique dynamics of organ maturation and changing metabolism in children.

Navigating Consent and Vulnerability

- Legal Competence vs. Developmental Capacity: While the law generally does not consider minors competent to provide consent, they are often asked for assent a verbal agreement to participate after the trial is explained in simple language.
- Vulnerable Subject Classification: Federal regulations provide extra protections for children because their ability to make autonomous decisions may be compromised.
- Standard of Care Comparison: Ethical research often involves comparing experimental treatments against the standard of care treatments a typical physician would customarily offer for a specific disease.

Specialized Ethical Challenges in Oncology

- Toxic Therapies: Cancer treatments like radiation and chemotherapy can be highly toxic, causing severe side effects like hair loss and weakened immune systems, with no guarantee of a cure.
- Therapeutic Misconception: A major ethical tension where participants or parents believe a trial is designed for their personal health benefit, whereas the true goal is gathering generalizable knowledge for future populations.
- Legal Precedents (Grimes v. Kennedy-Krieger): A 2001 Maryland case established that parents cannot consent for children to participate in nontherapeutic research that poses greater than minimal risk of injury.

Ethical Dilemmas in Epilepsy Research

- Diagnostic Challenges: Distinguishing between epilepsy and isolated seizures requires invasive tests like EEGs, which require both consent and assent.
- Refractory Epilepsy: Many childhood onset epilepsies do not respond to conventional drugs, creating an urgent, sometimes desperate need for experimental treatments or drastic surgeries.
- Financial Ethics: There is a constant ethical debate over whether the financial drive to bring new antiepileptic drugs to market quickly might occasionally trump patient safety.

Conclusions/action items:

This article highlights the urgent necessity of including children in clinical trials to develop age-specific treatments while navigating the profound ethical risks of therapeutic misconception and legal vulnerability.



2/13/25 Elastic polyester

KALOB KIMMEL - Feb 13, 2026, 1:36 PM CST

Title: Elastic Polymer

Date: 2/13/26

Content by: Kalob

Present: Kalob

Goals: Learn about Elastic Polymer

Source: <https://www.mh-chine.com/blog/products/polyester-stretch-fabric>

<https://www.mdpi.com/2073-4360/14/5/951>

Content:

- **Composition and Mechanics:** Polyester is a synthetic polymer (PET) often blended with elastic fibers like spandex typically 2–20% to create stretchability. The level of stretch is determined by the blend ratio, the weaving technique, and the fabric density.
 - **Durability & Recovery:** The fabric is highly resistant to wrinkles, shrinking, and abrasion. It features high "recovery," meaning it returns to its original shape quickly after being stretched.
 - **Moisture Management:** Its moisture-wicking properties and quick-drying nature make it a preferred choice for high-intensity activities.
- **Applications:** It is primarily used in activewear - leggings and jerseys, workwear - uniforms, and home decor like curtains because it maintains a polished look with minimal maintenance.
- **Functional Materials:** The research highlights various polyester-based materials such as PBSu (polybutylene succinate), PLA (polylactic acid), and PHB (polyhydroxybutyrate). These are often modified with additives like silver, graphene oxide, or essential oils to add antimicrobial properties.
- **Biomedical Innovations:**
 - **Wound Healing:** Electrospun nanofibers create highly porous scaffolds that mimic the skin's structure, allowing for controlled drug release and accelerated tissue regeneration.
 - **Tissue Engineering:** 3D-printed polyester scaffolds are being used to support bone formation and vascularized regeneration or to re-growing blood vessels.
- **Sustainability & Safety:** Unlike standard industrial polyesters, many of these medical variants are designed to be biodegradable, meaning they can safely break down inside the human body after completing their surgical or therapeutic function.

Conclusions/action items:

Commercial polyester is prized for its elasticity, wrinkle resistance, and durability in everyday apparel and home textiles, medical-grade polyesters are being engineered into biodegradable scaffolds.

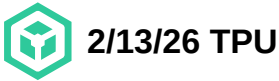

KALOB KIMMEL - Feb 13, 2026, 1:36 PM CST

Title: TPU**Date:** 2/13/26**Content by:** Kalob**Present:** Kalob**Goals:** Learn about TPU**Source:**<https://onlinelibrary.wiley.com/doi/full/10.1002/pat.6041><https://www.hlc-metalparts.com/news/what-is-tpu-material-85135316.html>**Content:**

Industrial Properties and Practical Utility

The general overview highlights TPU as a bridge material, combining the flexibility of rubber with the strength and processing ease of traditional plastics. Its chemical structure consisting of alternating hard and soft segments allows it to be melted and reshaped multiple times, which is a significant advantage for manufacturing and recycling.

- **Durability and Resistance:** TPU is renowned for its extreme abrasion resistance, outperforming materials like PVC and rubber. It also maintains flexibility at temperatures as low as -40°C and resists oils, greases, and many chemicals.
- **Versatile Applications:** Because it can be formulated to various hardness levels (from gel-like to rigid), it is used in everything from protective phone cases and medical tubing to automotive dashboards and industrial conveyor belts.
- **Sustainability:** Unlike thermoset rubbers, TPU is a thermoplastic, meaning it can be remelted and reused, offering a more eco-friendly profile for modern manufacturing.

Mechanical Performance in 3D Printing (SLS)

The research article focuses on the mechanical characterization of TPU when used in Selective Laser Sintering 3D printing. It emphasizes that while the material is highly effective for soft robotics and medical models, its performance is not uniform and depends heavily on how the part is printed.

- **Impact of Orientation:** The study found significant anisotropy, meaning the material's strength changes based on its print direction. For instance, horizontally printed specimens were 29% less stiff in tension but 15% stiffer in compression compared to vertical ones.
- **Advanced Testing Methods:** Researchers used 3D digital image correlation and micro-CT scans to observe how the material deforms under stress, providing precise data.
- **Technical Benchmarks:** For the specific powder studied, the material demonstrated a tensile strength of approximately 10.3 MPa and an elongation at break of 318%, confirming its suitability for flexible, rubber-like prototypes.

Conclusions/action items: Thermoplastic Polyurethane is a versatile, durable elastomer that bridges the gap between rubber and plastic, making it ideal for high-wear industrial and medical applications.



2/13/26 Ballistic nylon

KALOB KIMMEL - Feb 13, 2026, 1:36 PM CST

Title: Ballistic nylon

Date: 2/13/26

Content by: Kalob

Present: Kalob

Goals: Learn about Ballistic nylon

Source:

<https://link.springer.com/article/10.1007/s11665-024-09368-9>

https://www canvasetc.com/ballistic-nylon/?srsltid=AfmBOop1FARVMm1Nz2OpEGvcpnS4Rai1_HmqYLR6rbM5u9tpC5kkx-A5

Content:

- **Performance Optimization:** The study evaluates how the orientation and layering of fibers affect the structural integrity, impact resistance, and energy absorption of the material.
- **Mechanical Properties:** By combining the high tensile strength of carbon fiber with the toughness and impact resistance of Kevlar, researchers aim to create a "hybrid" material that outperforms single-fiber composites.
- **Practical Use-Cases:** These high-performance composites are primarily designed for demanding environments, such as aerospace components, automotive safety structures, and advanced protective equipment where weight-to-strength ratios are critical.

Ballistic Nylon Characteristics Ballistic Nylon is a thick, tough synthetic fabric characterized by its signature "basketweave" pattern.

- **Durability and Weave:** It is originally developed by DuPont for WWII flak jackets, it uses a 2x2 or 2x3 basketweave of high-tenacity nylon filaments, making it exceptionally resistant to tearing and abrasion.
- **Industrial Utility:** While no longer used for modern bulletproof vests its ruggedness makes it the standard for premium luggage, tactical gear, tool belts, and motorcycle apparel.
- **Maintenance and Coatings:** Most modern ballistic nylon is treated with Polyurethane (PU) or Durable Water Repellent (DWR) coatings to enhance its resistance to water and chemicals, ensuring long-term durability in outdoor environments.

Conclusions/action items: Ballistic Nylon is a tough fabric that the characterized weave pattern allows for significant resistance to tear and abrasion.



2/20/26 Dog bone MTS

KALOB KIMMEL - Feb 20, 2026, 11:08 AM CST

Title: Dog bone for MTS testing

Date: 2/20/26

Content by: Kalob

Present: Kalob

Goals: Made a dog bone in cad and researched it

Source: <https://fremontcuttingdies.com/dog-bone-tensile-test-what-why-who-and-how/>

Content:

What is a Dog Bone Tensile Test?

The dog bone tensile test is the industry standard for determining how a material reacts under tension. It involves pulling a standardized, specially-shaped specimen (the dog bone) until it breaks. This allows engineers to measure key mechanical properties, including:

- Ultimate Tensile Strength: The maximum stress the material can handle.
- Yield Point: When the material begins to deform permanently.
- Elongation: How much the material stretches before failing.

Why use the Dog Bone shape?

The specimen is narrow in the middle (the gauge section) and wider at the ends. This specific geometry serves two purposes

1. Focused Stress: The narrow center ensures that the material breaks in the middle rather than at the ends.
2. Better Grip: The wider ends allow the testing machine to grip the sample securely without causing "grip-induced stress" or slippage, which would skew the data.

Who uses this test?

This test is critical for industries where material reliability is non-negotiable:

- Plastics & Polymers: To see how much packaging or molded parts can stretch.
- Rubber & Elastomers: Testing seals, gaskets, and vibration-damping parts.
- Automotive & Aerospace: Ensuring lightweight materials can handle high loads and stress.
- Medical Manufacturing: Testing the durability and safety of implants and tubing.

Standards and Equipment

To ensure data integrity, the specimens must be cut with high precision using specialized dies. The tests typically follow global standards, most commonly:

- ASTM D638: For plastics.
- ASTM D412: For rubber and elastomers.

Conclusions/action items: The dog bone tensile test uses a specimen with a narrow center to focus stress and wider ends for a secure grip, ensuring accurate measurements of a material's strength and elasticity.

KALOB KIMMEL - Feb 20, 2026, 11:08 AM CST



[Download](#)

Dog_Bone.SLDPRT (75.6 kB)



2/27/26 Front toe sleeve material possibilities

KALOB KIMMEL - Feb 27, 2026, 1:00 PM CST

Title: Materials toe sleeve

Date: 2/27/26

Content by: Kalob

Present: Kalob

Goals: Learn about possible materials for the toe sleeve idea that I came up with.

Sources:

https://spandexbyyard.com/blogs/spandex-vs-other-stretch-fabrics-type-explained/understanding-power-mesh-and-lining-fabrics-for-activewear-amp-swimwearpower-mesh-and-lining-fabrics-activewear-swimwear?srsId=AfmBOoewAmsy-fNpLiTjWntL3A-KB1Gfw8EvUOJQd7SFC3_xVMMUPT-

<https://belloframelastomers.com/articles-and-news/everything-you-need-to-know-about-neoprene>

Content:

So for the sleeve I can think of a couple different route that we could go. We could go plastic which would assure stability and make it easy to apply dorsiflexion but it could have drawbacks with comfort. We could do a fabric like material which could have drawbacks with applying dorsiflexion, or we could look into a mesh like material. I'm going to start off with a few searches in this entry and then probably expand on this later.

Possible materials

- Power mesh fabric
- Neoprene
- Nylon spandex
- Polypropylene
- Silicone

These are what I could come up with in a short dive. I want to jump into Power mesh and neoprene

Power mesh

- A lightweight, sheer, warp-knitted fabric known for its optimal balance of flexibility, breathability, and structural support.
- Typically composed of 80–90% synthetic fibers usually Nylon, sometimes Polyester and 10–20% Elastane.
- Engineered with closely spaced holes (0.05 mm) forming a hexagonal or honeycomb-like net pattern.

Key Physical Properties

- **Stretch & Recovery:** Features active 4-way stretch with around 20% vertical stretch and 35% horizontal stretch. It has high modulus.
- **Weight & Thickness:** Generally low-profile standard weights are around 90–100 grams per square meter with a thickness of roughly 0.3 mm.
- **Tensile Strength:** Despite being sheer and lightweight, quality nylon-based power mesh is highly durable and can support considerable loads reportedly up to 20 lbs before failure
- **Breathability:** The open-knit structure facilitates excellent airflow and rapid moisture evaporation, preventing heat buildup.

Neoprene

- Neoprene is a highly versatile synthetic rubber also known as polychloroprene
- It is produced through the polymerization of chloroprene monomer units. Additives are introduced to enhance specific performance characteristics before the mixture is bonded into long chemical chains.
- It is manufactured in sheet, sponge/foam, extruded, and molded forms.

Key Physical & Mechanical Properties

- **Durability & Strength:** Exhibits exceptional resistance to physical wear and tear. It can withstand high levels of stress, strain, and abrasion without losing structural integrity.
- **Elasticity & Flexibility:** It can endure repeated bending, stretching, and compression, returning to its original shape without permanent deformation. This makes it excellent for shock/vibration absorption and secure molding.
- **Environmental Resistance:** It has a strong resistance to weathering, ozone, and UV exposure, making it highly suitable for outdoor and harsh environments.
- **Thermal Properties:** Offers moderate heat resistance and maintains good flexibility over a wide temperature range.
- **Chemical Resistance:** Highly resistant to a wide range of chemicals, notably including oils, fuels, solvents, acids, and alkalis.

Conclusions/action items:

So far I really like the look of power mesh. It seems to be fairly sturdy and should be realitively easy to fabricate a sleeve out of. I also like how low profile it is which would help keep it less noticeable to the user.



Toe sleeve 2/27/26

KALOB KIMMEL - Feb 27, 2026, 11:42 AM CST

Title: Toe sleeve to improve slippage**Date:** 2/27/26**Content by:** Kalob**Present:** Kalob**Goals:** Come up with solution for band slippage**Content:**

So our client did some testing with the current AFO that was sent out to them. The following are some major points.

- Decreased falling
- Lightweight and easy to maneuver
- A little hard to put together
- Band slippage
 - This is what I want to focus on for design in this entry

Overall this is really good to hear because although it is not a perfect solution, it is helping manage the symptoms. A few changes that come to mind to improve the AFO from here with the little amount of data that we have so far is improving the band and possibly making an instruction manual.

Three band improvements that I have come up with so far are:

- Sleeve around toes
- change of material/ addition of grippy material where contact happens.
- Toe ring/s

For these ideas I think one is so far the best idea, but I have not done any fabrication or testing to fully see yet. Currently I like the sleeve idea. I think that this design negates slippage from factors such as sweat while also assuming comfortability. If we added a type of rubber I think that sweat would provide the same barrier of slippage after durations of walking or being in warm environments. The reason I rule out the ring idea is because I think that it would be uncomfortable to have pressure inbetween toes. This leaves the sleeve which gives the ability to evenly distribute the tension at the furthest point of the foot yielding good dorsiflexion. Attached below are the sketches that I put together.

Conclusions/action items: Bring this up in the next team meeting, and discuss what types of materials could bode well if we went this route.

KALOB KIMMEL - Feb 27, 2026, 11:42 AM CST

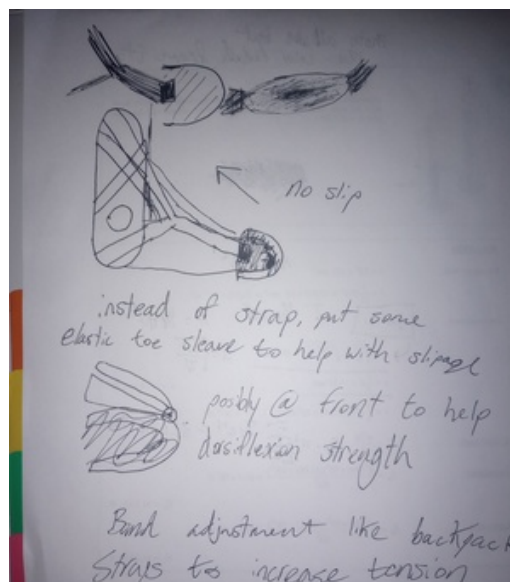



[Download](#)

IMG_20260227_112343335.jpg (3 MB)



3/13/26 OnShape medial lateral supports 3/13/26

KALOB KIMMEL - Mar 13, 2026, 11:47 AM CDT

Title: Working on updating medial lateral supports

Date: 3/13/26

Content by: Kalob

Present: Kalob

Goals: Make the medial lateral supports up to date for length and other measurements

Content:

So my job for this last week was to update cad and get it printed so that we could finish fabrication this week.

Updates made:

- **Changed dimentions of supports cut out so elongation would be viable**
- **Reformed both supports to the foot and ankle**
- Adjust infill

Printing out was pretty easy, I went to the makerspace and just used the downloaded onshape files and adjusted them then downloaded that will all settings as a 3MF to be printed

Post processing was not too bad, I made is so supports were on outside and they came off with just a bit off pulling.

Difficulties - Originally I thought that the cad was going to be very easy. When I went in to get everything adjusted it turned out that all dimensions were connected. When I tried to move and delete elements it was not working out well. After 2-3 hours I was able to change out a few of the defined points to where it was adjustable. After this I added new planes and then extended the support to the bottom of the foot. This took about an hour becuase I needed to see some tutorials on how to do it in onshape. The hardest part was by far getting the thickness to work. I spent 3.5 hours adjusting the supports trying to figure out why I could not add thickness to the support. I finally found that the issue was invisible and not super understandable. I had two points that were outside the supports that had a slightly larger curve that overlapped when I tried to add thickness past 0.06 inches.

Overall time - About 7 hours

Attached will be the supports as well as an image.

Conclusions/action items: Now that the CAD is done and printed, we were able to assemble the prototype monday - thursday! Some action item can be to look into how to adjust the cad in order to have the sock design possible because it would need extra straps.

KALOB KIMMEL - Mar 13, 2026, 11:47 AM CDT



[Download](#)

castingA_1 - Part_1.x_t (637 kB)

KALOB KIMMEL - Mar 13, 2026, 11:47 AM CDT



[Download](#)

castingB_1 - Part_1.x_t (603 kB)

KALOB KIMMEL - Mar 13, 2026, 11:54 AM CDT

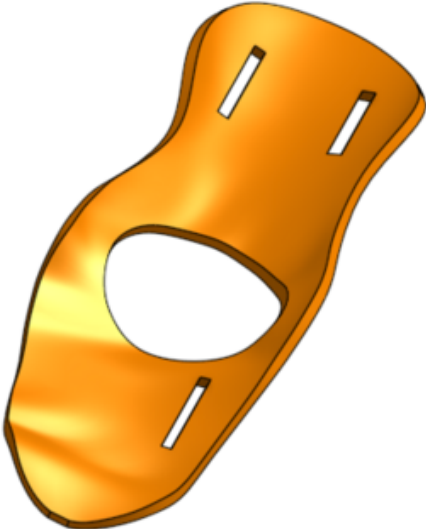

[Download](#)

Screenshot_178_.png (67.7 kB)



4/3/2026 Toe Sleeve design

KALOB KIMMEL - Apr 29, 2026, 4:38 PM CDT

Title: Toe Sleeve design

Date:4/3/2026

Content by: Kalob

Present: Kalob

Goals: Come up with the idea to decrease dorsiflexion strap slippage.

Content:

So, I've been thinking about how to solve that horizontal sliding issue, and I came up with this: the toe sleeve. It's a cotton, sock-like sleeve that slips over the front of the foot and anchors directly to the dorsiflexion strap using ballistic nylon arms we could either sew them on or use clips.

The main logic here is that by increasing the surface area in contact with the foot, we get way more friction, which should lock the strap in place and stop it from shifting. One downside is that it adds an extra step to putting the AFO on, so it might be a bit more of a hassle for the user. But overall we get much better strap stability in exchange for a slightly longer setup time.

Attached bellow is the drawing

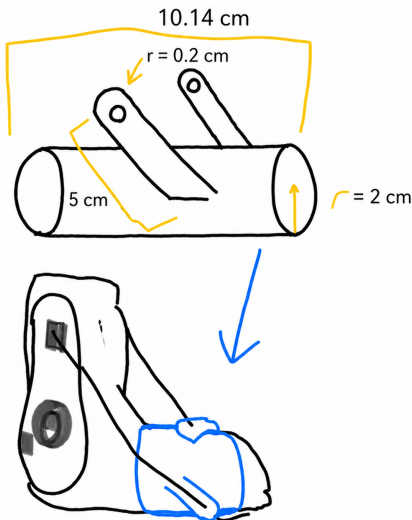

Conclusions/action items: Now we need to make a quick fabrication and try it out!



3/21/2026 Heel strap design

KALOB KIMMEL - Apr 29, 2026, 5:19 PM CDT

Title: Toe Sleeve design

Date:3/21/2026

Content by: Kalob

Present: Kalob

Goals: Come up with the idea to decrease dorsiflexion strap slippage.

Content:

Looking into the verticle slip, I came up with the idea of adding a heel strap. The idea is that this strap would act as an anchor to counteract the tension from the dorsiflexion strap, keeping everything aligned. Now, the trade-off is that it makes the AFO a bit more rigid and definitely harder to slide on, plus having that extra material under the heel might not be the most comfortable. This could come with less predictability for testing but it could also solve our problem of verticle slippage of the AFO, so I think it is something good to show the team!

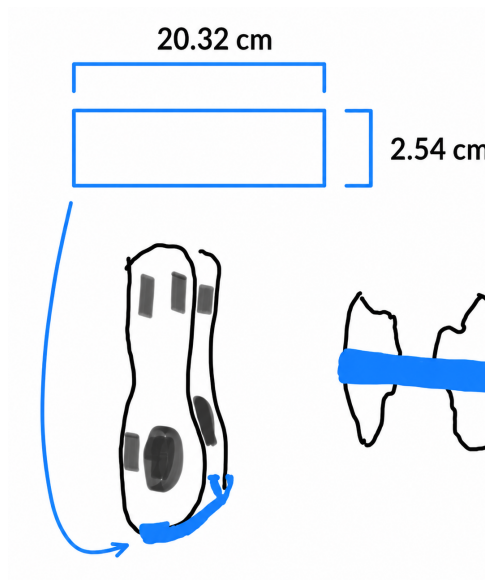

Conclusions/action items: Talk with the team and gauge if we want to add an extra strap or not



Chemical and Biosafety Trainings

KALOB KIMMEL - Feb 05, 2026, 10:46 PM CST

WISCONSIN
UNIVERSITY OF WISCONSIN-MADISON

This confirms that Kalob Kimmel has completed training for the following course(s):

COURSE	Accessed	Expiration	Expiration
Biosafety Recurrent Training	Biosafety Recurrent Training Class 2024	11/15/2024	11/15/2025
Chemical Safety: The 120861 Lab Standard	Final Exam	11/15/2024	
UW Human Subjects Protection Course	Basic Behavioral Science / Human Subjects Research	10/29/2025	10/29/2026

Data Last Imported: 11/24/2024 10:24 AM

[Download](#)

Chemical_and_Biosafety_training.pdf (58 kB)



3/16/26 Semester Training HIPAA

KALOB KIMMEL - Mar 16, 2026, 7:33 AM CDT

Grades for Kalob Kimmel Print Grades

Course: 2025-2026 HIPAA Privacy Arrange By: Due Date Filter

Name	Due	Submitted	Status	Score
2025-2026 HIPAA Privacy & Security Training Assignments	Mar 16 at 7:29am			100%
Assignments				100.00 / 100.00
Total				100% 100.00 / 100.00

[Download](#)

Screenshot_2026-03-16_073114.png (44.5 kB)

KALOB KIMMEL - Apr 08, 2026, 2:01 PM CDT

Screenshot_2026-03-16_073114.png

 **Lecture 2 Library**

KALOB KIMMEL - Jan 28, 2026, 1:52 PM CST

Lecture 2

Using the library

1/28/25

Chat bots & AI

- Predictive text generators they are not search engines. Do not evaluate for accuracy bias or credibility. can make up sources.

Data bases

- can get specific sources that go into depth with scholarly articles. Filtering is important to find articles that are pertinent to your topic.

- Check references to find other good articles

Citation Manager - Zotero

- can save searches to a citation manager in order to keep track of it for research purposes.

- Can start a group library for everyone in your group's citations

- Formats bibliography

Evaluating sources

- Relevance, Authority, Quality, Currency

Technical Reports

 **2/4/25 Lecture 3**

KALOB KIMMEL - Feb 04, 2026, 1:27 PM CST

Title: Lecture 3

Date: 2/4/26

Content by: Kalob

Present: Kalob

Goals: Learn about how to get better for job search.

Content:

I reviewed two peer job applications.

Conclusions/action items:

KALOB KIMMEL - Feb 05, 2026, 10:43 PM CST

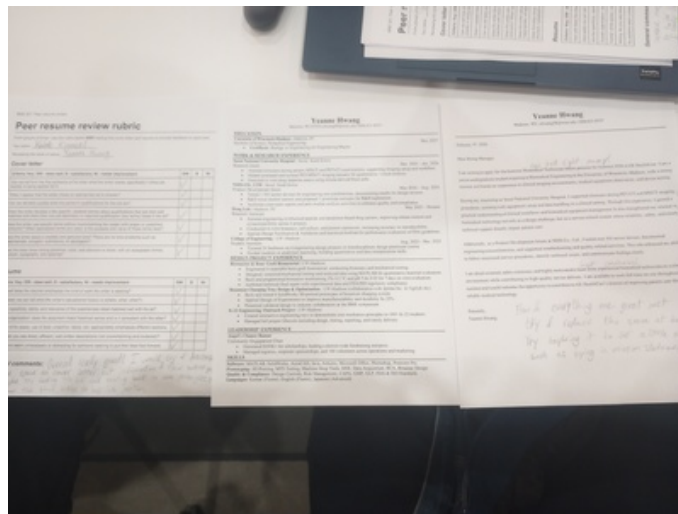

[Download](#)

IMG_20260204_135759847.jpg (2.67 MB)

KALOB KIMMEL - Feb 05, 2026, 10:43 PM CST

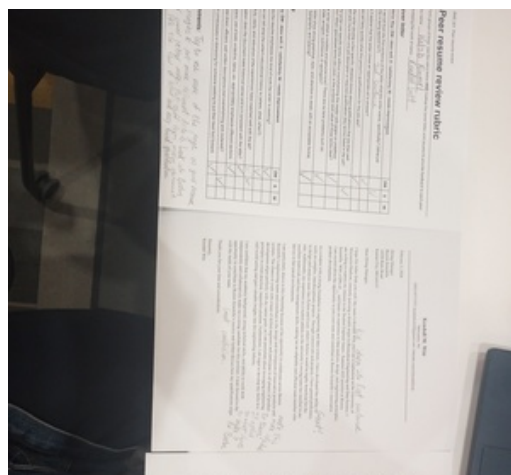

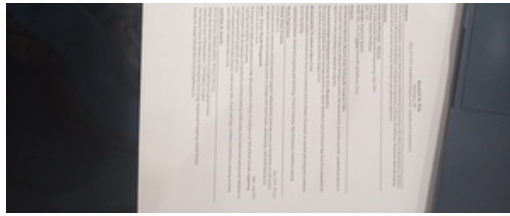

[Download](#)

IMG_20260204_135707634.jpg (3.18 MB)

 **Lecture on diversity and inclusion**

KALOB KIMMEL - Feb 25, 2026, 2:07 PM CST

Title: Diversity and inclusion**Date:** 2/25/26**Content by:** Kalob**Present:** Team AFO**Goals:** learn about div. and inc.**Content:**

Stuff that I think about are different backgrounds for diversity:

- Different financial backgrounds effect what designs are made
- Thoughts of inclusive designs such as different colored band aids
- Thoughts of learning disability for better instructions
- How well you slept last night. ate ...
- Universal design - different colored band aids, different size braces, culturally appropriate materials, available counter designs if needed.
- Definition - universal design is design that's usable by all people, to the greatest extent possible without need of adaptation.
- equitable use, flexibility in use, simple and intuitive use

Class activity:

- What could be improved upon in our project in order to make it more universal?
 - We could make different sizes in order to allow for options available to the general public, such as pediatric, small, medium, and large.
 - Better instructions on how to put on to help improve the principle of intuitive use.
 - multiple colors in order to make it more inclusive for different wants such as skin tone options

Conclusions/action items: There are a lot of actions that we could take with our design in order to make it more universal such as different sizes, colors, and instructions.



3/6/26 Tong Lecture

KALOB KIMMEL - Apr 29, 2026, 4:29 PM CDT

Title: tong

Date: 3/6/26

Content by: Kalob

Present: Kalob

Goals: Learn about the speakers Journey

Source:n/a

Content:

The tong lecture was extremely informative on Dr. Williams journey from growing up in very rural South Dakota to becoming a super successful inventor and professor. I was fascinated by the electrodes that he helped invent that were able to make the brain surgery so much less invasive. It is cool to see the small tweaks you can make in order to create a whole new product that is successful and impactful. I thought it was amazing to see clara and how she is seizure free after using a product developed by Dr. Williams. It was also pretty amazing to see him on Top 10 inventions on times magazine, and the happiness when one of his companies went public. Overall this lecture was so cool to see the potential there is for innovation and hard work!

Conclusions/action items: Look into brain electronics because all of the inventions were pretty amazing. Sending a tweet with your brain is pretty gnarly!



3/11/26 Protocal lecture

KALOB KIMMEL - Mar 11, 2026, 1:48 PM CDT

Title: Protocal lecture

Date: 3/11/26

Content by: Kalob

Present: Kalob

Goals: Learn about the speakers Journey

Source:n/a

Content: fail fast and early

low fidelity prototyping, circuit diagrams and circuit testing

fittings, simple calculations, FBD, mechanics of materials

planning general concepts for fabrication and testing

materials - detailed list = match material expense table + name of material, concentration, amount, dimensions, manufacturer, purpose of the material, list of equipment needed, reference papers

Methods - step by step plan

Rule #1 - repeatble

3D printing should have the gcode

Think ahead to manufacturing

Seek profesional advice

Jessie darlie - CAD

Testing above 3 hopfully more than 6

controls

Detailed fabrication play using the template - how favricatied, date to be completed.

Exteral fixtures for testing.

Working as a team to build a protocal

Conclusions/action items:

It is important to get testing done early so you can learn from failures and devop a polished protocol. Past this it is important to provide a ton of detailed information in protocal to make it easy to follow if you were not on the project.



3/18/25 Lecture on concise

KALOB KIMMEL - Mar 18, 2026, 1:35 PM CDT

Title: Protocal lecture

Date: 3/18/26

Content by: Kalob

Present: Kalob

Goals: Elevator pitch and presentations,

Source:n/a

Content: Be quick concise, and and have a call to action

elevator pitch- imediatly let them know goal

introduction

value proposition - target customer, howthe design solves a problem

unique features and venefits

call to action - what are you struggling with

Tong award - Intro - hi im ... and our project is ...

Attention grabber - we've developed a device to do X

Value proposition: Currently there is not a device to do X as existing technologies and pastents fail because of Y

Benefits: It is estimated that Z people would benefit from this device which has a potential market of \$, we have filed for a patent with WARF.
Demonstrate prototype fully

Dos and donts of elevator pitch - do - maintain eye contact and have confidence, keep consise and focused, tailor your pitch to different audiences

Don'ts overwhelm with unnecessary details, forget to listen and engage with audience, sound rehearsed or robotic

Executive Summary - 1 page Executive Summary - essentially an elavator pitch but on a one page document

Abstract last - start at end and it is a complete summary of the work for the semester 150-300 words - 250 most common

Conclusions/action items:



Ethics 3/25/26

KALOB KIMMEL - Mar 25, 2026, 1:42 PM CDT

Title: Ethics

Date: 3/25/26

Content by: Kalob

Present: Kalob

Goals: learn about ethics

Source: n/a

Content:

Where does ethics come from?

Personal ethics come from you

Professional ethics come from your workspace and the

BMES has a code of ethics that we should follow

Do i value ethics

Steps in design - establish a need, understand teh problem, generate solutions, evaluate solutions, develop detailed design

Ethical decision - awarness, stakeholders, options, and Analysis of options

Tests

Harm ,publicity, reversibility, universality, respect for person, utilitarian, social justice

Now we go through case study

Conclusions/action items:



Judgment 4/8/26

KALOB KIMMEL - Apr 08, 2026, 1:47 PM CDT

Title: Judgment

Date: 3/25/26

Content by: Kalob

Present: Kalob

Goals: Learn what engineering judgment is

Source: n/a

Content:

What is engineering judgment: Being able to take what you know to come to a conclusion

Abet makes sure our program is accredited

How do you learn engineering judgment, open ended- problems, teamwork and collaboration with others, critical thinking - evaluation of ...

Deesha Chadha - imperial college london

3 domain model

Attitudes - what you feel and believe about a specific issue

Behaviors - how you demonstrate and act upon your knowledge and attitudes while addressing a specific issue

Cognitive - what you know about and are able to do , to address a specific issue

Conclusions/action items:



Posters help 4/15/26

KALOB KIMMEL - Apr 15, 2026, 1:56 PM CDT

Title: Posters

Date: 3/25/26

Content by: Kalob

Present: Kalob

Goals: Learn what engineering judgment is

Source:n/a

Content:

What makes a poster good? Good data in legible figures, logical flow, big enough font, figure captions, thank TAs Instructors, and everyone who helped,

Bad: unorganized, undescribed data, font too small, not telling the story

getting started - show best results, not all of results

minimize text

colorful and high res pics/ graphics too explain concepts

Formating - captions- all figures and graphic must have captions

fonts - style must be easy to read

color - use for ease of reading to separate sections, and to highlight important points. (avoid harsh colors, too many , light background and dark text)

Must be able to read from 3 feet away, References in relatively small font, Reference all pictures/ graphics that are not your own, include enough white space to define important areas

Context of use and workflow - start with user and setting - show workflow before during and after and or inputs outputs, include user device interaction

place in a larger system

use color to organize what belongs use labels

Use a flow chart - know what it is

Handouts - especially at conferences - business cards, copies of poster, surveys, etc.

Have several other people proofread

Now it is worktime!

Conclusions/action items: Make a pretty poster!



Posters evaluation by peers 4/15/26 (copy)

KALOB KIMMEL - Apr 22, 2026, 2:08 PM CDT

Title: Posters

Date: 3/25/26

Content by: Kalob

Present: Kalob

Goals: Get feedback on our presentation

Source: n/a

Content:

Some feedback we got on our poster

too much white space in some areas

Change condition and impact into background

Make sure text is legible on poster for graphs

Rewording some areas

Changing graph formats

Now it is worktime!

Conclusions/action items: Make a pretty poster!



2/20/26 Preliminary presentation

KALOB KIMMEL - Feb 20, 2026, 11:35 AM CST

Title: Preliminary presentation

Date: 2/20/26

Content by: Kalob

Present: Kalob

Goals: Make my slides, practice and improve

Source: n/a

Content:

For this week I had to make my slides for our preliminary presentation and practice throughout the week. My slides are the concluding slides so I had to look into our current design and talk about the improvements and goals for the project along with concluding the presentation. Stuff that I highlight are the materials that we will use, improvements such as elongation of the carbonfiber side pieces, and goals of getting significant testing. We had class where we talked with another group about revisions that we could make, and some of the feedback was giving more context with the bullet points and summerizing the problem statment instead of having the whole statement. We met as a group to run it through and we hit 10 minutes on the dot so I am planning on talking a little more in depth for our final design to give us some buffer room.

Conclusions/action items: Continue practicing so that I can do well on the actual presentation.



2/13/26 BPAG Meeting, and updated Expenses from past semesters

KALOB KIMMEL - Feb 13, 2026, 12:33 PM CST

Title: BPAG Duties

Date: 2/13/25

Content by: Kalob

Present: Kalob

Goals: Learn about bpag in meeting

Content:

- Concept
 - Client purchases for you
 - We pay and then get reimbursed
- All expenses have to be Approved

- Three types of client matters
 - UW Affiliation
 - Using UW Funds - No
 - Anything is fair game
 - Client or you pay and then workout reimbursement if needed
 - Yes
 - Have to follow purchasing rules
 - Funding Strings
 - Makerspace, Team LABs etc
 - IF you pay at last resort work with accountant for reimbursement and tax will not be reimbursed
 - No Affiliation
 - Can be still funded through UW like out project which then we have to go through same process
- Shop UW
 - Have to purchase materials through these websites
- Shipping
 - Using University funds must have it shipped to university address
 - If sent to Pucc. then you need to add short name so he can identify
- Design labs
 - Access to a lot of tools and a market where you have \$50
 - Client can make an account for you to use there as well
- Reimbursement
 - Only BPAG is reimbursed
 - I divide the money up
 - For UW must have original receipts, valid project number, electronically submitted
 - 90 days after purchase there is no reimbursement

- Assistance
 - The notebook and poster are not reimbursable
- Accounting
 - There is a template that you can use
 - Exel it out in a way that it is easy to read
 - Use math functions to make it easy

Conclusions/action items:

Have client make purchases, Purchases through Pucc has a form, Get confirmation before buying.

KALOB KIMMEL - Feb 13, 2026, 12:35 PM CST

The image shows a screenshot of an Excel spreadsheet with multiple rows of data. The columns are labeled 'Description', 'Amount', 'Date', and 'Total'. The data appears to be organized into sections, possibly by month or category, with some rows containing dates and monetary values. The spreadsheet is partially obscured by a white box on the right side.

[Download](#)

Updated_Pevious_Semester_Expense_Spreadsheet_-_Sheet1.pdf (57.4 kB)



2/27/26 Preliminary Report work

KALOB KIMMEL - Feb 27, 2026, 12:21 PM CST

Title: Preliminary report

Date: 2/27/26

Content by: Kalob

Present: Kalob

Goals: get report done and summarize my work here

Source: n/a

Content: For the preliminary report I did the abstract, background and then evaluation. This meant that I was looking over the report and making small changes while I was gathering the best things to say for these. I was also giving some input. For my sections here is what I took away.

- Abstract
 - Problem identification of FSHD foot drop, disrupted gait, increased fall risks
 - AFO Judgment among high school peers
 - Design for 16 yr old
 - Obtain significant dorsiflexion support
 - Current prototype design
- Background
 - Touched on similar topics of abstract
 - Overall goal design a discreet and inconspicuous solution that provides support while bolstering confidence, independence, and overall quality of life.
- Design Evaluation
 - Project evolution
 - Start with dorsiflexion and a full sleeve
 - Shift to inversion eversion
 - Concealability
 - Current goal is to polish and end with significant data. LAST SEMESTER
 - Recent modifications
 - support padding
 - dorsiflexion bungee to polyester strap
 - No sock that makes it too noticeable
 - Patient noticed improvements with decreased falling

Conclusions/action items: Overall this was a long report and it took a good amount of time to read through and deliver the right conclusions. The main points it hits are the goals of the project with dorsiflexion etc. the modifications, and the future goals.



4/20/26 Final AFO Fabrication Day 1

KALOB KIMMEL - Apr 29, 2026, 4:48 PM CDT

Title: Final AFO Fabrication Day 1

Date: 4/20/26

Content by: Kalob

Present: Kalob

Goals: Get the AFO Printed out in Resin

Source: n/a

Content:

For printing out the AFO medial and lateral supports for the final design here is the process I took:

- First I got the support files downloaded as STL files
- I then talked to Design staff about the best printing options for the supports.
- We talked for about 45 minutes going between different options.
- There was the option of reprinting CF PLA and reducing print layer height.
 - I made the ultimate decision that this would still have a somewhat grainy finish
- We talked about resin options - Durable and Tough1500
- Both options were stellar and after the consultation I decided to go with tough 1500

Tough 1500 was chosen for its smooth finish printability paired with its strength and environmental stability. Tough 1500 has a high strength to weight ratio. This makes it easy for the patient to walk around without noticing the weight of the orthotic while still receiving the rigid support needed to stay steady. This stiffness is balanced with a pliability that allows it to withstand any bending moments applied without shattering or failing. It is also paired with a high memory that allows it to spring back to its original shape if it is bent. All of these physical features make it a great material for the supports because the weight does not significantly affect the patient's gait, and the strength provides all the support needed to help improve the patient's gait. It does this while also proving to be safe with its environmental stability and ability to be in contact with skin without any negative effects. Tough 1500 is a more expensive material to 3D print as it is a resin, with a cost of 25 cents per gram when printing at the Makerspace.

Conclusions/action items: Wait for the Supports to be printed and then start the final fabrication.



4/23/26 Final AFO Fabrication Day 2

KALOB KIMMEL - Apr 29, 2026, 5:02 PM CDT

Title: Final AFO Fabrication Day 2

Date: 4/23/26

Content by: Kalob

Present: Kalob

Goals: Get the AFO parts ready for fabrication TMR

Source: n/a

Content:

The Supports have still not been printed, so I now need to get all of the materials that I can prepare without the supports ready so that I have the ability to fabricate the AFO in 1 hour before presentations.

Here is the process I took:

- I cut out 2 ballistic nylon to 1 x 6 in
- I cut out 1 ballistic nylon to 1x 12 in
- I sewed the velcro onto the 1 x 12 in ballistic nylon
- I cut out the elastic band to 36 in
- I sewed the elastic band to the required 18 in and sewed down each of the sides to reduce elasticity
- I cut out and sewed together the double layered mesh
- I fabricated the toe sock prototype that helps with dorsiflexion slippage
- I learned how to thread a bobin
- I learned how to correctly thread the machine
- I learned how to replace bobins
- I learned the importance of thread distance and tightness

To see how all of this was done you can reffrence the fabrication protocol

Below is an image of the prefabricated parts for TMR



Conclusions/action items:Wait for the Supports to be printed and then start the final fabrication. I also became very proficeint with the sewing machine, as I took about an hour to master it before going on to fabrication.



4/24/26 Final AFO Fabrication Day 3

KALOB KIMMEL - Apr 29, 2026, 5:12 PM CDT

Title: Final AFO Fabrication Day 3

Date: 4/24/26

Content by: Kalob

Present: Kalob, Avery, Sierra

Goals: Finish the AFO

Source: n/a

Content:

The supports are done so now here is the process I took for finishing the AFO fabrication:

- I post processed the resin print
 - I cleaned off any extra resin
 - I cut off all of the supports
 - I sanded down some imperfections
- I cut the double layered mesh to fit the supports
- I sewed the sides of the double layered mesh to increase the stability
- I used super glue to adhere the double layered mesh to the inside of the supports
- I used sissors and fabric knives to cut holes throught the mesh allowing for the straps to pass through
- I sewed on the back ballistic nylon straps
- I sewed on the front ballistic nylon strap with the velcro
- I sewed on the dorsiflexion band with a twist to promote a flat laying of the band against the users foot

This concluded fabrication.

Full story behind the fabrication can be referenced in the fabrication protocol

Below is the final prototype



Conclusions/action items: Now I can show off the final product at poster sessions!