

Medical Device Cart

Advisor: Professor Block

**Client: Viasys Healthcare
Peg Rickard and Art Kealy**

**Joe Cabelka: Team Leader
Jennifer Wager: BSAC
Emily Andrews: Communicator
Tony Schuler: BWIG**

12/13/06

Table of Contents

Abstract	3
Background	
Project Motivation	3
Current Device	4
Electroencephalography	6
Ergonomics	8
Competition	9
Design Constraints	11
Materials	12
Alternate Designs	
Design I	13
Design II	15
Design III	17
User Survey Results	19
Final Design	22
Monitor	23
Keyboard Tray	24
System Components	25
Footprint	26
Push-bar	27
Cable Management	29
Additional Storage	30
Costs and Materials	31
Future Work	31
Ethics	33
References	34
Appendix A: PDS	36
Appendix B: Cart Usage Survey	38
Appendix C: Push-Bar data	40

Abstract

The goal of this project was to develop a cart that houses all the components for monitoring an electroencephalogram (EEG). The cart should be designed with respect to ergonomic standards to facilitate easy workflow and ensure the comfort and safety of the users, while maintaining a compact footprint and low production costs. Each of three preliminary design alternatives focused on one of the following aspects: usability at various heights, optimizing usable work surface, and storage and cable management. User survey information regarding the usability of the cart was obtained from current EEG technicians using the cart. From the user survey data we developed a final design which provides additional workspace with the addition of a mounted monitor and a sliding keyboard tray, more storage from rearranging the components and adding removable baskets, cable management, an adjustable push bar, and an open foot print for comfort. Our adjustments address all of the concerns of the customer while creating a more ergonomic design.

Background

Project Motivation

The goal of this project is to create an ergonomically correct device cart to house an Electroencephalography (EEG) system produced by Viasys Healthcare. The current cart that accompanies the components of the EEG system is often not purchased by Viasys' customers because it does not adequately meet their needs. Viasys currently receives many complaints and suggestions regarding their EEG cart. The current cart has no options for adjustment to accommodate multiple users, no leg or foot space, minimal work surface, minimal storage, and no solution for cable management. Our goal is to

research these specific complaints and, along ergonomic considerations, design a cart that not only fulfills customer needs but also facilitates easy, comfortable workflow to ultimately increase Viasys' customer satisfaction and profits. [16]

Current Device

Viasys Healthcare currently produces approximately 30 carts to store medical device equipment. They have had many complaints from their customers regarding the usability of all of their carts. They are interested in developing a new mid-sized cart to house their EEG equipment. If this project is successful in addressing customer concerns, Viasys anticipates transferring and applying many of our design concepts into a new line of carts.



Figure 1: Above is the current mid-sized cart from Viasys that would house EEG equipment.



Figure II: A current Viasys cart in use at the UW hospital fully loaded. Note the lack of additional storage space.

The main problems encountered with the current cart regard usability at multiple heights, lack of work surface, and minimal storage and cable management. The current cart has no adjustable components making it very uncomfortable people of various heights to use. The push bar on the back of the cart is mounted at one height which is not ideal for pushing. Also, the push bar is mounted too close to the back of the cart for the user to walk and push the cart comfortably with hitting their feet. Additionally there is virtually no work surface on the cart for filling out charts and other tasks that may need to be performed in addition to the EEG procedure. The monitor and keyboard occupy all of the desk space. Furthermore, there is no additional storage space for items, including cleaning supplies, the user may require aside from the components of the EEG system. Finally, the cords from the EEG components are loose and not organized. The cables get in the way of task performance and are often run over when moving the cart. In general, the current cart from Viasys hinders work flow and is not adequate for its user population. [16]



Figure III: Note the minimal storage space on a current fully loaded cart.

Electroencephalography

The electroencephalography or EEG procedure records brain waves used to detect electrical activity in the brain. Abnormalities in the brain can be detected by recording the electrical impulses that the brain uses to communicate. An EEG primarily records the impulses from the cerebellum which controls speech, thought, memory, and voluntary actions. The cerebral cortex is responsible for higher brain functions, the thalamus carries signals from the sensory organs to the brain, and the reticular activating system sends signals to the body to sleep and wake. This procedure is also often used to measure the electrical signals in the cerebral cortex, the thalamus, and the reticular activating system.



Figure IV: Here you can see a picture of the EEG procedure taking place. [7]

The procedure involves a technician arranging electrodes, typically around 12, on the patient's head. The electrodes are fixed into place with sticky paste. The patient must remain still during the procedure as movement can interfere with the signals. The electrodes transmit the electrical signal to an amplifier and the results are recorded in the system's software.

EEGs aid in diagnosing and managing several disorders. The EEG is a critical test in diagnosing and managing areas of unstable electrical impulses in the brain that result in epilepsy. Other rare seizure disorders can also be identified with EEG and treatments can be monitored as well. An encephalopathy is any disease that alters brain function and can be caused from many different sources, which are also diagnosed by EEG. EEG results may identify coma or stupor by a marked lack of electrical activity. EEG is the main procedure used to identify and monitor many brain disorders.

The essential components of an EEG machine include electrodes, an amplifier, a computer, and a monitor. An EEG machine may also include a camera and/or a photic. In designing a cart to house an EEG system, all of the components must be accounted for. [6] [12] [17]

Ergonomics

Viasys Healthcare's existing EEG cart is designed with little attention to ergonomic standards. As expressed in customer reviews, both the comfort and ease of use during sitting or standing have been neglected. Users have also articulated their need for more surface top workspace and reduced keyboard and monitor footprints. The current cart has proved inappropriate for its user population, as it is designed without respect to anthropometric data or adjustability standards.

In order to ensure that our team's final design will improve upon the EEG designed by Viasys Healthcare, we have completed diverse research into anthropometric data, standards, and guidelines. Both FDA and AAMI standards documents have lead us to consider several ergonomics and human factors design approaches including the evaluation of the user population, environment characteristics, and interaction between the device, its user, and the environment. Additionally, in interviewing EEG technicians, we have informally observed a walk through of the procedure to better understand importance, frequency of use, function, and sequence of use. Our team has distributed a brief survey internationally in order to more accurately collect such data. Finally, we have accessed anthropometric data regarding the workspace and tasks involved in the EEG procedure. This data will be applied in our final design as a means of addressing this device's ranging user population.

Our goal in approaching our design from an ergonomics perspective is to correct immediate issues as demonstrated in Viasys Healthcare's customer reviews and mitigate the potential for future problems. After incorporating ergonomics concepts into our

design, we expect that a ranging audience will be accommodated to more effectively and comfortably perform the intended task. [3]

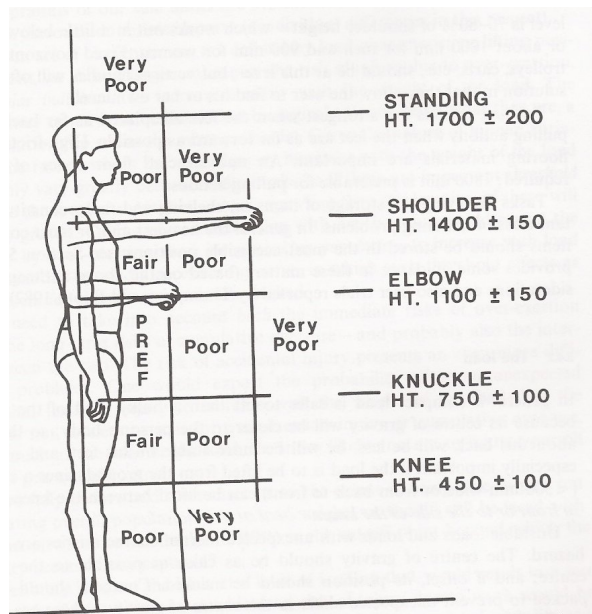

Figure V: A figure showing average heights for ergonomics.

Competition

To gain a better understanding of existing models, our team researched competitors' EEG systems and carts. There are some advantages and disadvantages to many of the carts we looked at. Many have a very small footprint to optimize space, but in turn lack work surface and storage space. Other models incorporate storage, but are generally bulky and may be obtrusive in medical environments.



Figure VI: This cart from Grass-telefactor is very compact with a small footprint, but has minimal workspace and storage. The wings are also awkward and intrusive [4].



Figure VII: This cart from XLTek is also compact, but is lacking workspace and storage.[13]



Figure VIII: This cart from EGI gives a neat appearance, but is somewhat bulky and has minimal workspace. [9]



Figure IX: The cart from Hospital Management is compact, but requires an additional component and has no workspace. The keypad is also obtrusive. [2]

Design Constraints

Our new cart must remain approximately the size of the mid-sized cart currently produced by Viasys; the footprint must maintain the same dimensions. The cart must house all of the components of the EEG systems including a computer, monitor, amplifier, camera, and photic. The cart must address usability concerns with regards to ergonomics so Viasys can offer a more comfortable and efficient cart. The materials used must agree with health and safety standards of medical environments. The material used to construct the cart must also be durable and light enough to easily maneuver. Additionally, the cart must be cost efficient in that any elevated costs are justified by the advantages. [16]

Materials

To construct our cart we require a material that is durable, light and preferably inexpensive. The concept of stress and strain were employed to evaluate the materials. Stress is a measure of force per area and strain is its deformation. We evaluated durability by Young's Modulus (or its elastic modulus) which is a measure of rigidity. A material with a higher elastic modulus requires more stress for the same strain as another material. We evaluated its weight based on its density in pounds per cubic inches and we looked at each materials price per cubic inch.

We evaluated low-carbon steel, grade 2 titanium, and aluminum alloy 6061 as potential construction materials.

<i>Material</i>	<i>Density (lb/in³)</i>	<i>Elastic Modulus (ksi)</i>	<i>Price (\$/in³)</i>
Low-Carbon Steel	0.28	29,000	0.75
Grade 2 Titanium	0.17	16,000	18
Aluminum alloy 6061	0.098	10,600	1

Table I: Low-carbon steel, Grad 2 Titanium, and Aluminum alloy 6061 are compared based on density, elastic modulus, and price.

As noted from the table, steel is the strongest and least expensive material of the three, but also the heaviest. Titanium is way too expensive for our use. The aluminum seems to be the best choice because it is the lightest material and while it is the least strong of the three materials, it has a high enough elastic modulus to work as well as the current steel does. Aluminum is also inexpensive. [6] [11] [15] [18]

Alternate Designs

For our alternated designs, we addressed each of the three main concerns: usability at various heights, workspace, and storage and cable management.

Design I: Usability at various heights

In this design we address the push bar, uncomfortable workstation, and camera and photic placement. We propose to make the push bar adjustable through appropriate heights for both males and females and to mount it further back from the cart to allow a comfortable pace when walking and pushing the cart. The mechanism we propose for the adjustability would be a simple peg such as in crutches. To make the workstation more comfortable, we will rearrange system components to create an open footprint allowing for more foot space. We will also use a sliding keyboard to create expandable depth, providing knee space when sitting at the cart. The camera and photic are currently mounted in an obtrusive manner and are difficult to reach and adjust. Our solution is to mount the camera and photic on a single central pole so as to eliminate awkward reach angles.



Figure X: The crutch above demonstrates the form of adjustment we propose for the push bar on the back of the cart.



Figure XI: Here you can see the limited knee space when sitting at the current Viasys cart. With a sliding keyboard moved under the cart, there will more knee space to make working at the cart much more comfortable.

Design II: Workspace

Our second design focuses on maximizing the usable worksurface of the cart. Many EEG technicians had difficulties finding a workspace to take notes during the procedure. Nearly all usable workspace was covered by components such as the keyboard, mouse, and monitor. To combat this problem, we propose to mount the monitor on a fully adjustable boom. Not only would this lift the monitor off the cart surface, increasing workspace, but make the monitor easy to view from many different angles. For example, many times EEG technicians need to be next to the patient while setting up all the equipment. Previously, a technician would constantly be looking back and forth between the patient and monitor, and even moving back and forth between the cart and patient. As one can imagine, this was very inconvenient. By mounting the monitor on a boom, however, this problem can be eliminated. The boom operates around a single pivot point, allowing the monitor to move up and down, side to side, and even pivot on the end of the boom. With such a wide range of motion, the monitor can be seen from all over. Secondly, we found it beneficial to add a swiveling mouse pad on the retractable keyboard, which is mounted below the cart surface. Once again, this removes the existing awkward mouse pad from the cart surface increasing workspace. The original mouse pad hinged into place on the side of the cart during use, but when removed for transport, the thin steel plate just sat on the surface of the cart. The new swiveling mouse pad, located under the cart surface, does not need to be removed during transport, and even swivels under the retractable keyboard for easy storage.



Figure XII: A fully adjustable boom with a mounted computer would give more workspace and allow the monitor to be viewed at different angles. The camera would also be mounted to the



Figure XIII: Here is a sliding keyboard with a swivel keyboard mounted underneath. [8]

Design III: Storage and Cable Management

Our third designed focuses on the problems with cable management and storage space. Right now, cables are generally unorganized and greatly interfere with cart movement. Many times the cables slide off the cart and get tangled in the wheels, creating a mess that is aesthetically unpleasing. Also, the less intimidating equipment a patient sees, the more comfortable they feel during the procedure. To address the cable mess, we decided to make the two most frequently used cables retractable, coiling up into a semi-permanent housing. The other cables will be labeled and stored in a cable caddy, which will contain pegs that the cables will coil around. The cables would also be concealed with a door to hide cables from the patient, while still allowing easy access for maintenance. Storage space on the cart for additional supplies is minimal. At the UW hospital, many technicians had to add their own small basket to the bottom of the cart to store sterilizing supplies. To optimize storage space, we felt a combination of several ideas would be the best approach. Shelf space already existing on the cart could be maximized. We also made the shelves slide so as to gain easier access to any stored items. Finally, we decided to add pegboard to the sides of the cart. By adding pegboard, baskets and hooks can be hung on the cart for any additional storage.



Figure XIV: Here is a simple sliding shelf that would be used to give more storage space and allow the CPU to be easily accessible. [12]



Figure XV, XVI: On the left a retractable cord casing would be used for the power cords that are used frequently and on the right is a peg set up that could be employed to coil the additional cords. [3]

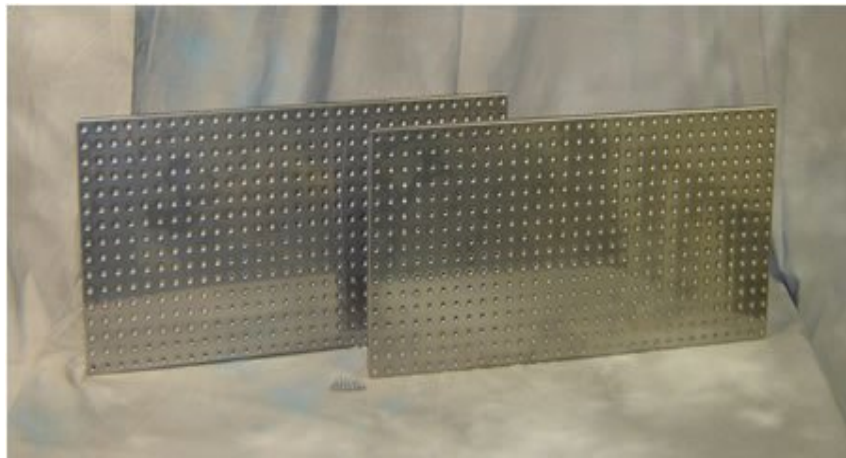

Figure XVII: Metal peg board where storage bins could be attached would give additional storage space. [1]

User Survey Results

We developed a user survey and Viasys distributed to technicians using the current EEG cart. Results from seven technicians were obtained. The survey can be referenced in Appendix A.

A. Numerical Data

	Survey 1	Survey 2	Survey 3	Survey 4	Survey 5	Survey 6	Survey 7	Average Response
Question 1	1	1	1	1	1	2	1	1.14
Question 2	2	3	2	2	2	4	3	2.57
Question 3	4	3	2	3	3	4	5	3.43
Question 4	2	3	2	1	3	2	3	2.29
Question 5	2	2	2	1, 2, 4	2, 5	1, 2	1, 2	2.00*
Question 6	5	5	8	5	8	8	8	6.71
Question 7	3	5	4	3	4	4	4	3.86
Question A	1	2	2	4	2	4	5	2.86
Question B	5	4	5	5	4	2	1	3.71
Question C	5	4	5	4	5	5	5	4.71
Question D	5	4	5	4	2	4	5	4.14
Question E	2	4	2	3	4	3	5	3.29

*2.00 represents the mode for Question 5

B. Free Response

3) On a scale of 1-5, with 1 being the most uncomfortable and 5 being the most comfortable, rate how comfortable it is to sit at the unit. Elaborate if possible.

- Not bad if we don't use the mouse extension. Could use more leg room no place to write on the tech sheet. Have to put a mat on the bottom shelf of our equipment scratches it easily.
- Top surface too small to write.
- There is not enough room for me to slide up to the computer keyboard. No where for my feet and legs. I must sit sideways.
- It's uncomfortable because it's small. But it's also not bad-it could be worse.
- There's no place to put your knees.
- Sometimes knees hit the cart.
- Very comfortable in that I use the bottom shelf as a foot rest when in the operating room for long periods.

4) On a scale of 1-5, with 1 being the most uncomfortable and 5 being the most comfortable, rate how comfortable it is to stand at the unit. Elaborate if possible.

- Have to bend over quite a bit-not comfortable on the back or neck at all.
- Easy to push.
- The keyboard sits too low to stand and run the computer and type.
- It is too low to be standing at for taller people.
- Fine to stand, push cart around hospital. However, awkward to reach keyboard and use while standing.
- Have to crouch over to be able to type or use mouse when not sitting.
- Have to bend over if using the system while standing; hard on the back.

6) On a scale of 1-10, with 1 being the least mobile and 10 being the most mobile, rate the mobility of the cart (e.g. at 10, you would feel comfortable taking the unit across cobblestone, and at 1 you would not wheel the unit down the hall.) Elaborate if possible.

- It fits most places, but not all. Doesn't go over cords very well-comes to a dead stop and things can fall off. Would never dream of going across cobblestones.
- Easy to push but does not seem sturdy enough.
- Wheels have good mobility (finally!)
- It rolls nice on flat surfaces inside, but it's not for use outside on cobblestone. Rolls nice inside.
- Cart moves well, however can get "hung up" on bumps.
- Wheels get hung up on elevator and does not wheels over wires and cords very well.
- Cable/cord connections (all) seem to loosen or fall out with movement over time.

F) If there was just one thing you could change about the cart, what would it be?

- More storage, more leg room.
- Cart is the best yet-of all that have been used in the lab.
- More leg room.
- None.
- Better cable management. Have a sliding keyboard so as not to hit knees on lower shelves.
- Better wire and cord hooks and better organization.
- More rotation on amplifier; cable/cord organization. Baskets on side would interfere with mobility.

C. Data Interpretation

It is important that our final design meets the needs of Viasys Healthcare's customers. In order to better understand the needs of this audience, we surveyed seven EEG technicians at the University of Wisconsin-Madison Hospital regarding their frequency and sequence of use while performing tasks involving Viasys' EEG cart.

This survey served as a tool to gain insight into the benefit of some of our initial brainstorm ideas; some were incorporated into our final design and others were not perceived as useful by the technicians.

Results from this survey influenced our team's design. The following general conclusions are based on averages.

Technicians:

- Stand at the cart between 1 and 2 hours daily.
- Sit at the cart between 4 and 5 hours daily.
- Rated sitting at the cart 3.43 out of a possible 5.
- Rated standing at the cart 2.29 out of a possible 5.
- Suggested the most frequently used system components are the keyboard and mouse.
- Rated the mobility of the cart 6.71 out of a possible 10.
- Rated the size of the cart 3.86 out of a possible 5.
- Thought the addition of a rotating top would probably not be beneficial.
- Were indifferent about additional storage.
- Thought a sliding keyboard would probably be beneficial.
- Thought a sliding or retractable mouse pad would probably be beneficial.
- Were indifferent about sliding shelves.

Based on this feedback, we focused our design on accessibility while sitting since more time is spent in this position, but incorporated adjustable components to allow for comfort while standing as well. We also added the sliding keyboard tray and mouse pad

to make the mouse and keyboard most readily accessible. Per Viasys' request, we maintained the existing wheels and did not adjust the cart's frame so as to avoid major changes in current manufacturing processes. Finally, we adapted our initial brainstorm ideas to best suit the needs of the technicians.

Final Design

Based on our survey results and input from Viasys, we developed our final design. The final design consists of alterations to the monitor, keyboard, push bar, system components, and footprint along with a solution for cable management and additional storage. With our alterations, our final design addresses all of the concerns of the users and our clients. Our final design allows the entire surface of the cart to be used for workspace, additional space for the user's feet and legs, an adjustable push bar to accommodate users of various heights, and organized cables and additional storage.



Figure XVIII: Here you can see the final design from the front and back. The front features rearranged components, sliding keyboard, and mounted monitor. The back features the adjustable push-bar, cable management, and additional storage.

Monitor

We chose to mount the monitor on a fully adjustable boom, which can rotate 360 degrees, extend on its arm, and can also be adjusted vertically; these adjustability features enable the user to achieve both the ideal viewing angle and distance, which are 15 degrees below the horizontal. This will reduce neck strain and allow technicians to view the screen from various angles while working with the patient at bedside.

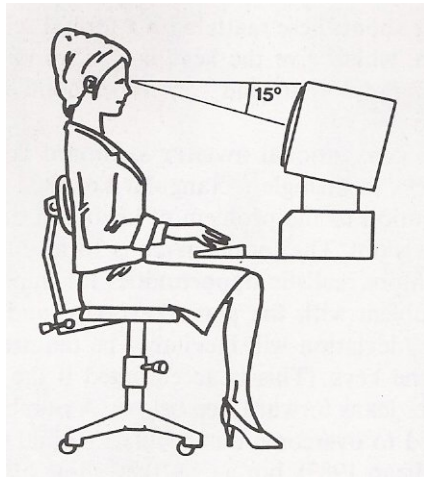

Figure XIX: Here you can see the appropriate sitting position when viewing the monitor.

Additionally, lifting the monitor footprint from the surface top has created additional work space requested by technicians for recording data and taking notes on patient charts.

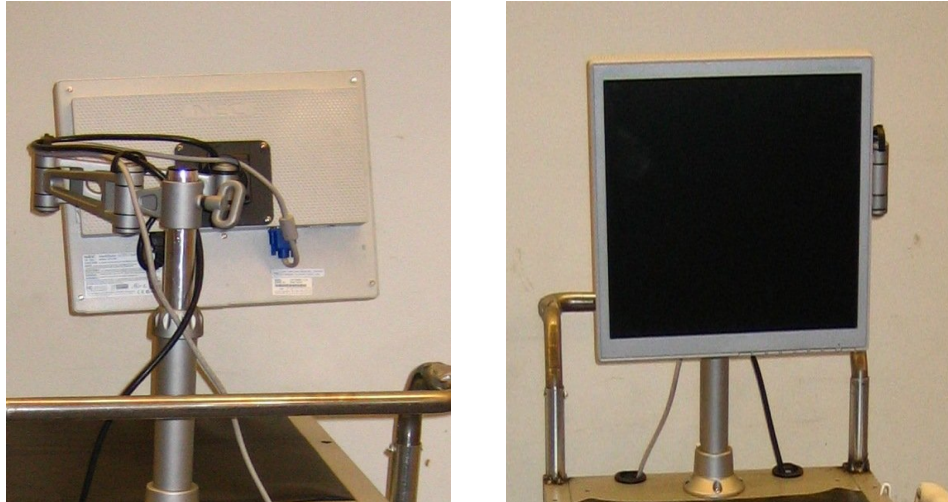

Figure XX: The monitor and the adjustable boom is shown from the front and back. The monitor can now be seen at multiple angles and adjusted up and down for comfort.

Keyboard Tray

Placing the keyboard and mouse on sliding tray has proved another successful method for eliminating surface top clutter. The simple adjustability of the keyboard tray allows for comfortable typing while sitting or standing without a complicated system of levers and buttons. This will prevent technicians from bending over to type while standing and eradicate back and neck pain. The impermanent depth of the sliding keyboard tray also allows for the user to comfortably sit at the cart without hitting their knees and creates the ergonomically correct 90 degree angle.

Finally, a swivel mouse pad is attached to the sliding keyboard tray for convenient storage under the tray, which can be stored under the desktop during transport. This system can be set up to accommodate and manage cables associated with a standard

keyboard and mouse. However, we recommend a wireless keyboard and mouse be purchased for a total of approximately \$50-\$100 in order to eliminate excess cables.



Figure XXI: The keyboard is now on a sliding keyboard tray with a swivel mouse pad. The keyboard tray allows for knee space when sitting and frees up surface space. The keyboard tray can also be accessed at a comfortable standing height.

System Components

In order to incorporate the sliding keyboard, we had to re-arrange some of the system components. We decided to put the computer upright instead of having it take up a shelf. We also put the power box on the bottom of the cart and moved the middle shelf all the way down. We moved the top shelf as far down as possible to increase the utility of the shelf. Unfortunately, the keyboard tray does limit what can be put on the shelf, but it also opens up the top of the top of the cart. Also, if needed, another shelf could be placed in between the bottom and the top shelves.



Figure XXII: Here you can see the components have been rearranged. The CPU now sits vertically and the power box is on the bottom shelf. This optimizes space.

Foot Print

One of the complaints we heard from people at Viasys and others who use the cart as a workstation was about space for their feet. Currently they either rest them on the cart or slide them under the cart. Both situations are lacking in long term comfort. By cutting away the bottom of the cart, users can easily rest their feet on the floor. Aside from that, the extra room, along with pulling sliding the keyboard out, creates more leg room which allows the users to stretch to the most comfortable position.

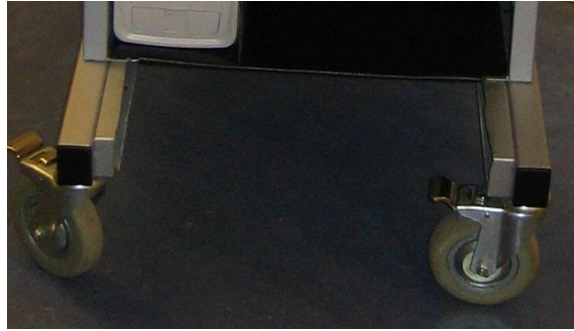

Figure XXII: A portion of the bottom shelf has been cut out to allow for an open foot print as shown. This gives room for the feet when sitting.

Push-bar

To truly make the new cart as ergonomic as possible, we also had to deal with the ever present problem of the push-bar. The current push-bar was very short, too close to the back of the cart, and overall problematic. In order to fix these problems decided to introduce two simple, yet highly effective changes. First, we decided to extend the push-bar horizontally away from the back of the cart in an attempt to prevent users from kicking the back of the cart while pushing it to various locations, and secondly, we decided to make the push-bar adjust vertically in order to make it easily used by people of various heights. [3]

To extend the push-bar horizontally, two small lengths of steel pipe were inserted on both sides of the current push-bar and then welded into place. The fabrication for this part of the push-bar was relatively simple, however, coming up with the correct length for the inserted length of pipe was slightly more complicated. In order to make the cart as ergonomic as possible, the inserted length of pipe was determined through a series of calculations using average anthropometric data averages for males and females. It is also important to know, that when performing the calculations, all anthropometric data was

weighted 75% toward the female range, because 75% of the population using the cart are females. The only time weighting was not used, was in the measurement for average stride length, in which only the male data was used for clearance. Using only the male data allowed us to cover both the male and female ranges so that neither sex would have problems with kicking the back of the cart. After all the calculations were finished, the inserted length was determined to be 1.07 inches (see Appendix C for data and calculations).

To create a vertically adjustable push-bar was more difficult in fabrication, but slightly less difficult in calculation. Once again, anthropometric average data was used in determining the vertical adjustment range of the push-bar; however, calculations didn't work out as nicely this time around. In order to make the push-bar adjustable for both male and female ranges, it would need to dip below the surface of the cart and rise nearly 20 inches off the top of the cart. As one can see, this simply wouldn't fit with the dimensions of the current cart. Instead, a 4 and 3/8 inch length of steel pipe already present on the current push-bar was used for the vertical adjustment range. This worked out well because the range covered the majority of the female height data range as well as some males of below average height, not to mention it made fabrication slightly less complicated (see Appendix C for data and calculations). To fabricate the adjustable push-bar, two lengths of steel pipe (slightly longer than 4 and 3/8 inches to allow clearance for drilling) were welded to the top, back corners of the cart. These two lengths of pipe acted as "sleeves" for the push-bar to slide up and down in. The sleeves were then drilled out, as well as the push-bar (in multiple places along its length), so that the push-bar could be locked into place at various heights with a simple nut and bolt

mechanism. After the horizontal extension and vertical adjustment changes were implemented, the new cart contained a fully adjustable and ergonomically sound push-bar.

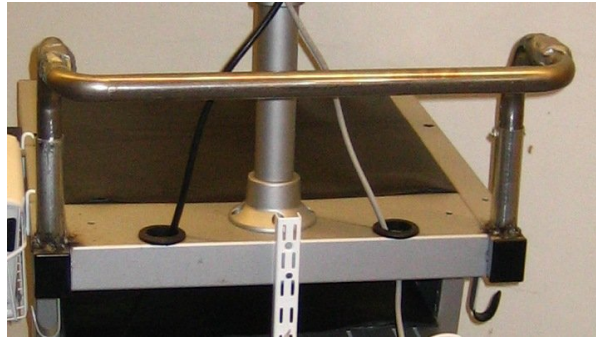

Figure XXIV: The push bar as shown slides to various heights and locks into place with a nut and bolt mechanism. It is also pulled back closer to the user.

Cable Management

A major complaint of the current cart was the lack of cable management. The cables from the system components hung loosely and would often get caught in the wheels while moving the cart. The lack of organization also made it difficult to reach the desired cable for maintenance or another reason. It is also a factor in the patient's comfort during the procedure; seeing the unorganized cables led to the patients anxiety. To address this problem, a racking system was mounted on the back of the cart. The racking system consists of two racks with eight hooks each. The cables from the components can be easily wound upon the hooks and organized.



Figure XXV: The racking system shown is mounted to the back of the cart. The cables can be wound and organized on the hooks.

Additional Storage

When we visited the University of Wisconsin Hospital, we noticed that the technicians stored various items on the cart. To provide additional storage for these items, we added holes to the side of the cart where removable baskets can be placed in. We chose to use a basket that accommodates the amplifier and the mouse, but any sized basket can be used or non at all depending on the users needs.



Figure XXVI: The storage basket shown fits into holes on the side of the cart. As shown, the amplifier can be conveniently stored.

Costs and Materials

We were given a budget of \$500 for this project with the goal to obviously spend as little as possible. Because the more money that is put into the cart directly corresponds with the price of the cart for the customer, we tried to keep costs to a minimum as to maintain the appeal of the cart. The money we spend were on items that we felt justified the cost due to the ergonomic benefits. Below is a summary of our costs for the semester.

Material	Cost
Keyboard Arm and Keyboard Tray	\$216
Hook System	\$16
1" and ¾" Steel Piping	\$10
Non-slip material	\$10
Wire basket	\$4
J.B. Weld	\$4
Screws	\$2
	Total= \$272

Although we spent a total of \$272, we are confident that Viasys could locate or manufacture a less expensive keyboard tray that could be substituted. With our adjustments, we project the cost of the cart to increase by \$200 to \$300 mainly due to the addition of the monitor arm and keyboard tray.

Future Work

Unfortunately, we did not end up with enough time to test our prototype. When thinking about possible tests, we decided the best way to gauge the cart's appeal would

be to send out another survey. They would be sent out to current customers and include questions relating to comfort and ease of use and overall opinion. Our prototype could then be lent to customers for a period of a week or so and then they would be asked to fill out the same survey for the prototype. This would at least give some qualitative feedback as to whether or not the new cart is better than the old one. On top of that, it gives a basis for some iterative design. Viasys could take the information from the survey and adjust the prototype accordingly, ultimately making a prototype that many people are happy with.

When designing our cart, we did not want to adjust the height or dimensions of the current cart to avoid changing the manufacturing process dramatically if Viasys decided to build a few prototype carts. In designing our cart, we researched average body heights and comfortable table heights for sitting and standing, along with reaching angles and lengths. If Viasys wanted to build another prototype, they might want to take into consideration these measurements as they might help to further increase the overall comfort of the cart.

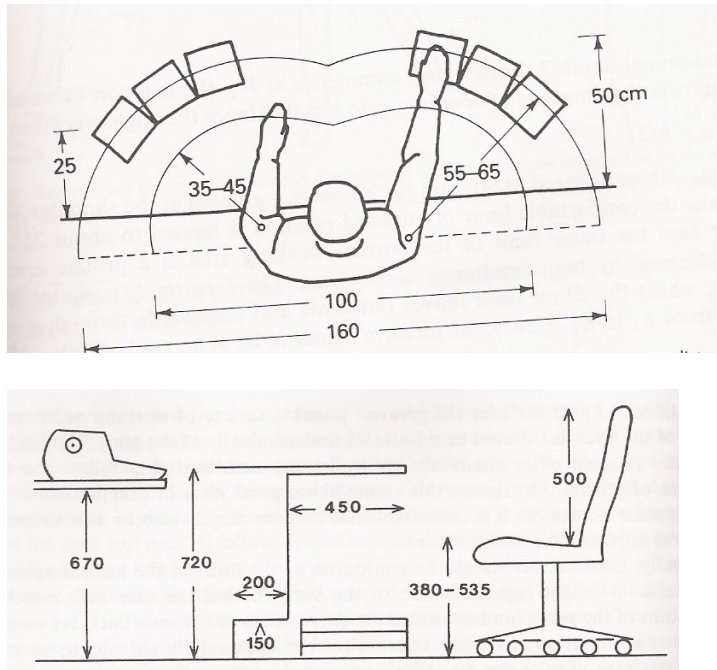

Figure XXVII, XXVIII: Shown are two figures of ergonomic workspaces. In the future we hope to employ this data to create a completely ergonomic device cart by altering the manufacturing process for the cart.

Ethics

Because this project is being done for a company, it is important not to violate any current patents. Most likely, the patent holders will wait to object to the work Viasys did until they have a finished product that they are selling. Once they are in this position, the patent holders that feel their patents have been violated will file suits for royalties, putting Viasys in a very bad position.

References

- [1] “Alligator Board” 16 October 2006 <http://alligatorboard.com/>
- [2] “Best Medical Systems: EEG recording station” 27 September 2006.
<http://www.hospitalmanagement.net/contractors/imaging/bestmedical/bestmedical2.html>
- [3] Bodyspace: anthropometry, ergonomics, and the design of work Stephen Pheasant
Taylor & Francis, London, 1996
- [4] “Cable-Safe” 13 October 2006 <http://www.cable-safe.com/products/index.htm>
- [5] “Comet® Portable EEG - Recording & Review” 27 September 2006
<http://www.grass-telefactor.com/products/clinsystems/cmeeeg1.html>
- [6] “EEG Machine.” 25 September 2006 <http://www.madehow.com/Volume-7/EEG-Machine.html>
- [7] “EEG Procedure” 25 September 2006. <http://www.epshp.fi/kotisivu/knf/EEG.jpg>
- [8] “Efunda” 17 October 2006. <http://www.efunda.com>
- [9] “Ergo-In-Demand” 13 October 2006. <http://www.ergoindemand.com/keyboard-tray-adjustable-shelf.htm>
- [10] “Geodesic EEG System 140” 27 September 2006.
http://www.egi.com/r_ges140.html
- [11] “Global Spec” 17 October 2006. <http://www.globalspec.com>
- [12] “Kids Health” 25 September 2006.
<http://kidshealth.org/parent/system/medical/eeg.html>
- [13] “Kitchen Shelves” 16 October 2006.
http://www.kitchenshelves.com/basic_shelf.htm

[14] "Kortex EEG" 27 September 2006. http://www.xltek.com/WEB/prod_kortex.html

[15] "McMaster-Carr" 17 October 2006. <http://www.mcmastercarr.com>

[16] Rickard, Peg and Art Kealy, personal interview. 18 September 2006.

[17] Sabbatini, Renato M.E. "Mapping the Brain." *Brain & Mind* 25 October 2006.

<<http://www.epub.org.br/cm/n03/tecnologia/eeg.htm#topography>>.

[18] "Suppliers Online" 17 October 2006. <http://www.suppliersonline.com>

Appendix A

Project Design Specifications

Project #42 – Medical Device Cart

Function: The purpose of the medical device cart is to provide a work area that houses all components for monitoring an electroencephalogram (EEG). The cart should be compact and facilitate easy work flow. It should also be designed with ergonomic standards in mind to ensure the comfort and safety of the users.

Client requirements:

- Cart should conform closely to the measurements of a current medium size device cart
- Issue of cable management should be addressed
- Cart must be comfortable and have ergonomic design in mind

Design requirements:

1. Physical and Operational Characteristics

- Performance requirements:* Device must have room for a monitor, computer, printer, amplifier, camera, photic and power supply. Device must be maneuverable and easy to transport.
- Safety:* Device must have regulatory power supply. Non-regulated safety considerations include sharp corners and dangling cords.
- Accuracy and Reliability:* N/A
- Life in Service:* Cart should be able to withstand 10 years of usage. Cart should also be designed with future considerations in mind to prolong life.
- Shelf Life:* N/A

f. *Operating Environment*: Device will be used in a medical setting. As such, it must be easy to clean. Materials should comply with safety standards for a medical environment.

g. *Ergonomics*: Two points of concern are keyboard height and ease of mobility. Keyboard and surface top should be appropriate for use while sitting or standing. It also must be easy to push and rotate. Customers need to view the monitor from various angles.

h. *Size*: Cart should not differ greatly from existing medium size device cart.

i. *Weight*: Should be kept to a minimum for shipping (ideally 50-75 lbs) and should be easy to push or pull.

j. *Materials*: Any material that can be used in a medical setting and reduces weight.

k. *Aesthetics, Appearance, and Finish*: Must be aesthetically pleasing to customers. A unique image will help build product identification.

2. Production Characteristics

a. *Quantity*: 1

b. *Target Product Cost*: Total cost of cart: \$800-\$1500

3. Miscellaneous

a. *Standards and Specifications*: Cart must meet The Health and Safety (Display Screen Equipment) Regulations of 1992. It also must meet IEC 60601-1 [Medical Electrical Equipment – Part 1] and in particular clause 24 which requires that the device will not overturn if tilted through an angle of 10 degrees. Additionally the cart must comply with the Association for the Advancement of Medical Instrumentation (AAMI) and Food and Drug Administration (FDA) Human Factors regulations.

d. *Competition*: Several other companies produce similar carts intended to assist in various medical procedures. Some customers purchase EEG systems from Viasys, but prefer carts designed by other companies.

Appendix B

Cart Usage Survey

Questions:

- 1) How long do you use the cart each day while standing?
 - a. 1-2 hours
 - b. 3-4 hours
 - c. 5-6 hours
 - d. 7-8 hours
 - e. >8 hours

- 2) How long do you use the cart each day while sitting?
 - a. 1-2 hours
 - b. 3-4 hours
 - c. 5-6 hours
 - d. 7-8 hours
 - e. >8 hours

- 3) On a scale of 1-5, with 1 being the most uncomfortable and 5 being the most comfortable, rate how comfortable it is to sit at the unit.

Elaborate if possible: _____

- 4) On a scale of 1-5, with 1 being the most uncomfortable and 5 being the most comfortable, rate how comfortable it is to stand at the unit.

Elaborate if possible: _____

- 5) What part of the cart do you use the most?
 - a. Monitor
 - b. Keyboard/Mouse
 - c. Camera
 - d. Amplifier

- 6) On a scale of 1-10, with 1 being the least mobile and 10 being the most mobile, rate the mobility of the cart (e.g. at a 10, you would feel comfortable taking the unit outside across cobblestone, and at 1 one you would not wheel the unit down the hall.

Elaborate if possible: _____

- 7) On a scale of 1-5, with 1 being large enough only to keep stationary and 5 being small enough to fit anywhere the unit needs to go, rate the size of the cart.

In this next section, we will ask your opinion about features of the cart. Put an X next to the option that you feel best describes your reaction.

(Yes) (Probably) (Indifferent) (Probably Not) (Definitely Not)

1. Would a rotating top be beneficial? _____

2. Would additional storage be beneficial (such as a basket on the side)?

3. Would a sliding keyboard be beneficial?

4. Would a sliding or retractable mouse pad be beneficial?

5. Would sliding shelves be useful? _____

6. If there was just one thing you could change about the cart what would it be?

Appendix C

GATHERING OF
SH-BAR: calculations

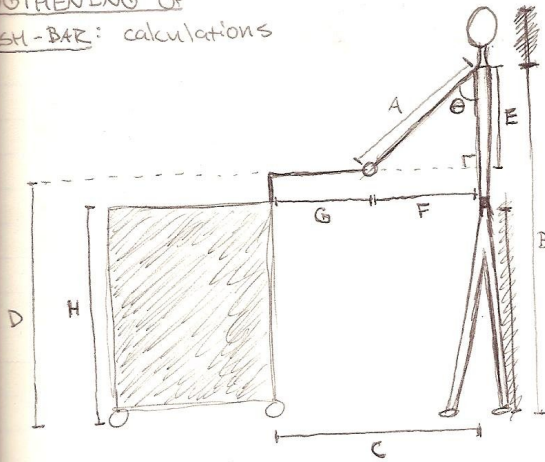

* NOTE: All ranges of measurements are weighted 75% toward the female end because 75% of the people using this cart are females.

given; cart height = $\boxed{29.0 \text{ in.}}$
(H)

average shoulder grip length (A) \Rightarrow female 605 mm \rightarrow male 655 mm $\Rightarrow \boxed{24.31 \text{ in.}}$
 $(605 \times .75) + (655 \times .25) =$ converts to inches

- this type of calculation will be performed on all the following measurements

average shoulder height (B) \Rightarrow female 1310 mm \rightarrow male 1425 mm $\Rightarrow \boxed{52.71 \text{ in.}}$

average stride length (C) \Rightarrow .415 x height for males = $(.415) \times \left(\frac{1795}{10} \cdot \frac{1}{2.54}\right) = \boxed{28.51 \text{ in.}}$
 .413 x height for females = $(.413) \times \left(\frac{1615}{10} \cdot \frac{1}{2.54}\right) =$ ~~27.81 in.~~

- I ~~used~~ ^{used} the male numbers only for a clearance on stride length, if the extended push-bar cleared the male stride length, it would clear the females as well. ~~the female stride length is 27.81 in.~~

average elbow height (D) \Rightarrow female 1015 mm \rightarrow male 1100 mm $\Rightarrow \boxed{40.80 \text{ in.}}$

$E = B - D = \boxed{11.91 \text{ in.}}$

$\theta = \cos^{-1}\left(\frac{11.91}{24.31}\right) = \boxed{60.7^\circ}$

$\sin(\theta) = \frac{F}{24.31} \rightarrow F = \boxed{21.19 \text{ in.}}$

current length \nearrow
 $7.32 \text{ in.} - 6.25 \text{ in.} = 1.07 \text{ in.}$
 \searrow minimum inserted length of tubing

$G = C - F = \Rightarrow \boxed{7.32 \text{ in.}}$ for clearance w/ male ~~clearance only~~
~~this works well because the push-bar already extends back 6.25 in.~~
 * this works well because the push-bar already extends back 6.25 in.

VERTICAL PUSH-BAR
ADJUSTMENT: calculations

elbow height \Rightarrow male

1005 - 1140 mm } avg = 1100 mm
(5%) (75%)

- range is from 5th \rightarrow 95th percentile of males, covers a wide range.

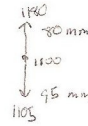

female

930 - 1015 mm } avg = 1015 mm
(5%) (95%)

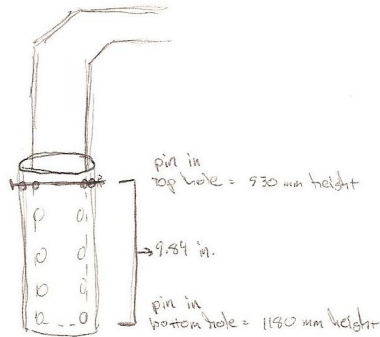
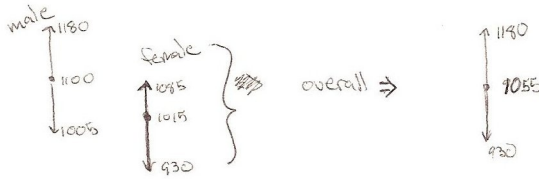
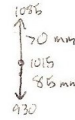

NOTE: This 9.54 in. range is far too large and will not fit well with the cart. 930 mm is ~~below~~ below the surface of the cart, and the 1180 mm height would be nearly 20 inches above the surface of the cart. Because of this, ~~and~~ I decided to use a 4 3/8 in. range already present on the push-bar (see following page)

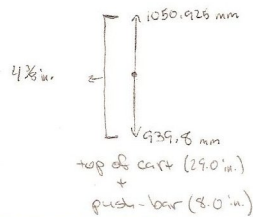

* This range is good because it caters more to females which is good for the 75% weightings, also caters to some males, and will fit better on the cart.