

Motor Skills Tester

BME 200/300

Fall 2006

Client: Marina Emborg, M.D., Ph. D.

Advisor: Kristyn Masters, Ph. D.

Team Members:

Kailey Feyereisen (Team Leader)

Gina Stuessy (Communications)

Cali Roen (BSAC)

Lacey Halfen (BWIG)

October 25, 2006

Table of Contents

Abstract.....	2
I. Introduction and Product Motivation.....	3
II. Current Products and Materials	3
III. Client Design Requirements.....	4
IV. Design Alternatives.....	4
V. Design Matrix.....	7
VI. Ethics.....	7
VII. Conclusion.....	8
Appendix A: PDS.....	9
Appendix B: References.....	11

Abstract

Primate testing is essential in the medical field. Variables such as motor skills can be easily generalized back to humans, but the results are only as reliable as the test is. The devices used to test motor skills in primates are usually attached to the cage, and the monkey is encouraged to retrieve a reward (usually food) from the device. The time taken to complete the task is recorded, and used to judge the motor skill ability of each primate. These devices are designed to test each hand specifically as well, as measurements may vary depending on which hand the monkey uses. If a monkey is not able to complete a task with one hand, it may try to use the other, and the device should not allow for this, as it would skew test results.

Currently, the devices used tend to be too cognitively challenging. The photodiodes used to measure time become dirty easily, which causes them to fail. The devices are complicated, and difficult to clean properly. Additionally, the software used to record results is overly complicated.

Our client, Dr. Marina Emborg, would like us to design a device to test the fine motor skills in rhesus monkeys. She studies the effects of Parkinson's disease on motor skills, and needs a better way to measure its effect. At this point in time, she would like us to focus on redesigning the apparatus, with the possibility of continuing the project on into future semesters to focus on the electrical and software aspect of the design.

I. Introduction and Project Motivation

Our client, Dr. Marina Emborg, studies Parkinson's disease, a degenerative neurological condition that results in many devastating symptoms, such as tremor, bradykinesia (slow movement), hypokinesia (diminished movement), and balance and gait disturbances (Emborg, 2004; Wikipedia, 2006). In order to study the effects of the disease and possible treatments, she performs tests on primates. By measuring the motor skills in monkeys that exhibit symptoms similar to the disease, Dr. Emborg is able monitor its progression, administer a treatment, and test to see its effectiveness.

Current devices used to measure motor skills of primates are available, though expensive. They usually record the time taken for the monkey to retrieve a reward from an obstacle, and use this measurement as an indication of motor skill. The device used by Dr. Emborg depends upon photodiodes to record these times. Due to the design, these photodiodes are difficult to clean. When they become dirty, the signal fails, resulting in poor results. It is also imperative that any device designed to test motor skills minimizes the cognitive portion of the task. Any time spent figuring out *how* to complete a task interferes with results meant to indicate time spent *performing* the task. Dr. Emborg is also unhappy with the current device with respect to this aspect, and would like us to design an apparatus that would further minimize cognitive problem solving (Emborg, 2006).

II. Current Products

Dr. Emborg currently utilizes a device called the Monkey Movement Analysis Panel, or mMAP, to perform motor skills testing on rhesus monkeys. The mMAP was developed by the University of Kentucky Medical Center in Lexington, KY (Grodin and Wang, 2000). Specifically, the mMAP measures the speed of coarse and fine motor movement of the monkeys' hands and arms. The device is made of clear Lexan and attaches to the front door of the monkey's cage. The current product allows researchers to test a specific arm.



Figure 1: Researcher demonstrates testing using mMAP device.

To test the monkeys' motor skills, the researcher places a small food reward at the center of the device. The monkey then retrieves the reward by guiding its arm through two separate holes in the mMAP (Figure 1). Three photodiodes at each hole measure the amount of time the monkey takes to grab the food. Another physical aspect to this device is the armhole portal door. The first hole

the monkey places its hand through has a door that the researcher can close between tests (Grodin and Wang, 2000).

Another device currently in use in other research labs is a detached design. This device is not attached to the monkey's cage, but instead it sits in front of the cage. The detached design consists of a base platform with eighteen divots, nine on each side (Figure 2). In the center is a clear plastic divider to encourage the monkey to use either the right or left hand to retrieve the food reward placed in the divots. Because this device does not have a photodiode system, the data that the device gives is qualitative, not quantitative.

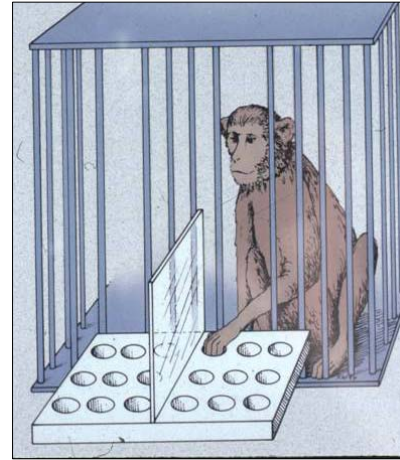

Figure 2: Detached design

III. Client Design Requirements

The apparatus we are designing needs to be easy to clean. It will be used in testing with both monkeys and food rewards, and a clean environment is important for health purposes. The design should facilitate cleaning of the photodiodes as well, so there is nothing obstructing the signal and interfering with the data collected. The device also needs to be less cognitive than the current design in order to test motor skills instead of the time it takes for the monkeys to figure out how to reach the food. The device should ideally be adaptable for human motor skill testing to aid in future research. It should be durable and attach securely to the cage.

IV. Design Alternatives

In each of the design alternatives, similar photodiode systems are used to measure time spent completing the task, as well as facilitate easy cleaning to promote a clear signal. Along the outside of each sensory hole there will be photodiodes to monitor motion of the monkey's hand as it passes through. In order to keep the photodiodes clean, they will be covered with a clear, durable material that will allow for easy cleaning.

The device chosen will be made from a durable, transparent material, such as Plexiglas. Because money is not an issue, alternatives to Plexiglas, such as Lexan, may be used to promote cleaner cuts during the manufacturing process. The material should be easy to clean and durable enough to withstand daily abuse from the monkeys. The material chosen should be compatible with any cleaning solvents that may be used.

Hinged Box Design

The hinged box design attaches securely to the cage and the monkey will reach its hand through two holes to attain the reward (Figure 3). The first hole leads just outside the cage, and the second goes into a box. The reward can be placed to either side of the second hole to test each hand individually. The top of the box is placed on hinges. This allows for easy reset of the device, as well as quick cleaning. Because of the hinged design, the top of the box must be latched securely before the monkey is allowed to attempt the task. If this is not done, the monkey could grab the top of the device and possibly pinch fingers or otherwise injure itself.

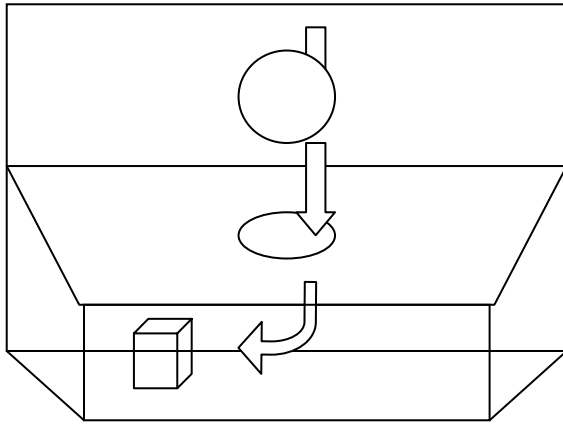

Figure 3: Hinged box design

In order to standardize position of the reward, thus standardizing results, the device will also include small wells on the bottom of the box. This is where the reward will be placed. It is important that the wells are not made too deep, as many of the older monkeys are missing digits. As a result, it is difficult for them to retrieve rewards from deep wells, and this would compromise results for motor skills.

There are many advantages to this design. Because of the set-up, there is very little cognitive challenge expected. The device is fairly simple, and would be easy to manufacture. Also, with the hinges on the top of the box, clean up and reset of the device will be fast and easy.

There are, however, several important disadvantages to this design. Although it is quite simple, the motion required of the monkey to retrieve the reward may be physically impossible. Additionally, this design will be difficult to adapt to human testing, should the need arise.

Simple Box Design

The simple box design consists of a box with removable side panels. These removable panels allow the researcher to conduct either right- or left-handed testing of the monkey (Figure 4). We would also build an

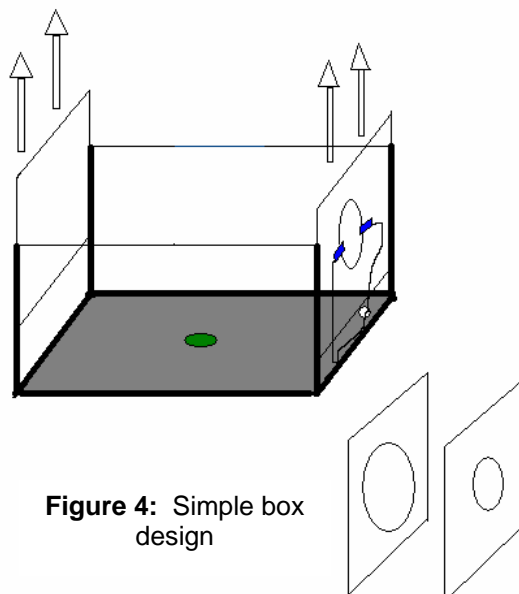

Figure 4: Simple box design

alternative side panel with a larger hole to allow the device to be used for human testing. In this design, the food reward would be placed in the center bottom of the box. The monkey would guide its hand through the holes in the removable side panels and retrieve the food, which will sit in small wells.

This design has many advantages over the current product. First, it is less cognitively-based; it tests the monkeys' physical abilities instead of its mental abilities. Second, it is easier to clean because the panels are removable. This design is also readily adaptable to human testing with the alternative side panel.

There are, however, disadvantages in this design that must be considered. Because the panels are removable, they would need to be fastened down so the monkeys will not disturb them. If not, the monkey may interfere with the photodiode system. Also, this design will have several sharp edges. This is an important safety concern for both the monkey and the researcher. Both issues can be addressed during manufacturing to provide a better design.

Staggered Box Design

The staggered box design consists of two holes with sensors that are slightly staggered in parallel walls. This creates a diagonal path for the monkey to reach the food reward (Figure 5). The path is directly in front of the monkey, with only a slight curve to encourage the use of a specified arm. This approach reduces the cognitive aspect of the test, because the path to the food is more intuitive. The device also contains a slight, central well for the food to standardize testing.

The staggered box design has several advantages. It is easy to clean because of the open top. It also provides less cognitive challenge than the apparatus currently being used. Additionally, it is a simple design that would be very easy to build.

There are several disadvantages to this design as well. Because the path to the food is so direct, it may not force the monkey to use the specified arm. Furthermore, the device would be difficult to adapt for human testing due to the dimensions that must be used to accommodate the monkeys and their cage.

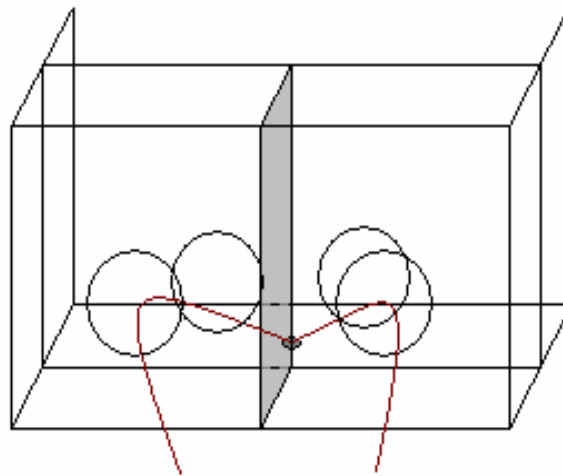

Figure 5: Staggered box design

V. Design Matrix

After the advantages and disadvantages of each of the proposed designs were considered, a design matrix was created to evaluate each design statistically and to help decide which design to proceed with.

Table 1: Design Matrix

Design Alternatives	Cognitive Simplicity (1-10)	Ergonomics (1-10)	Adaptability for human testing (1-5)	Total Points (3-25)
Hinged Box	10	5	1	16
Simple Box	8	9	5	22
Staggered Box	9	9	1	19

Several criteria were used to evaluate the design, with the more important criteria weighted more heavily (see Table 1). The two categories weighted the most important are cognitive simplicity and ergonomics of the potential design. These categories are weighted highest because they are among the most important design specifications. It is important to Dr. Emborg that the tester is less cognitively challenging than her current product. The tester also needs to be able to test each of the monkeys' hands separately, and it must be physically feasible for the monkey to bend his arm through the holes. Also, Dr. Emborg would like the tester to be adaptable for human testing. The highest score that a design could receive on this scale is twenty-five points and the lowest that it could receive is three points. Using the matrix evaluation, the simple box design scored the highest. This design will be finalized and a prototype will be constructed.

VI. Ethics

The motor skills tester will be in contact with food, monkeys, and humans. For this reason, it is important that the device be safe and clean. There should not be any dangerously sharp edges on the tester. Also, any electrical components must be out of reach of the subjects being tested. The diodes on each side of the hole will be covered in transparent plastic so that they the subjects tested are not at risk. The material of the device, the food, and any cleaning supplies used must not be toxic.

VII. Conclusion

Now that our three design alternatives have been evaluated, the materials and exact dimensions for the simple box design will be decided. After receiving input and approval from Dr. Emborg, the tester prototype will be constructed. Next, either the design team or Dr. Emborg will use the device to test monkeys' fine motor skills and make a comparison to the current product.

Because of the scope of the project, completion will take two semesters. If the project is continued, the second semester's work will focus on developing a software program to run the motor skills tests, constructing a circuit to connect the tester to the computer, and fine-tuning the electrical diodes to signal properly.

Appendix A: Product Design Specifications

Function: Design an apparatus to test the fine motor skills of rhesus monkeys that minimizes the cognitive portion of problem solving; should be easy to clean, durable, adjustable for human testing, and attach to cage securely.

Client Requirements:

- Improvement on fine motor skills tester for rhesus monkeys
- Ability to test specific hand
- Signals / diodes on openings
- Tester easily cleaned

1. Physical and Operational Characteristics

- a. *Performance Requirements:* Device must secure tightly to the cage and withstand force of the monkey banging or kicking. It will be used multiple times a day and must be easy to reset and clean quickly.
- b. *Safety:* Product must hook securely to the cage and all parts must be securely fastened. There cannot be any sharp edges or exposed or loose wires. Only nontoxic food rewards must be placed in the tester.
- c. *Accuracy and Reliability:* Device must be symmetrical to ensure testing accuracy between the right and left arm trials. The food rewards must be of consistent size and location.
- d. *Life in Service:* Product should have a lifespan of at least five years.
- e. *Shelf Life:* Device should be stored at room temperature in a clean environment.
- f. *Operating Environment:* Device should be cleaned regularly to ensure diode function. It needs to withstand shock-loading and corrosive conditions.
- g. *Ergonomics:* Food must be within easy reach of the monkey. If it is too far away, test results will be compromised. Entrances should be large enough for human testing. Food should not be placed in wells that are too small for the monkeys' fingers to reach into. Older monkeys' disabilities should be kept in mind.
- h. *Size:* Device needs to have the same width as the monkey cage, and should not be deeper than the monkeys' reach.
- i. *Weight:* Device should be light enough to not put a strain on the cage.
- j. *Materials:* Device cannot be cleaned with toxic chemicals. Materials should not become toxic when corroded.
- k. *Aesthetics, Appearance, and Finish:* Able to slide into monkey cage, transparent, smooth edges and surfaces.

2. Production Characteristics

- a. *Quantity:* At this time the client only requires one unit.
- b. *Target Production Cost:* Current unit cost \$2,800. Project budget is \$5,000.

3. Miscellaneous

- a. *Standards and Specifications:* Local standards and international standards need to be met.
- b. *Customer:* Able to be adjustable for human testing, be cleaned easily, and have working electronics.
- c. *Patient-related concerns:* Device should be sterilized and compatible for monkeys' cages. Electronics should be compatible with computer programs.
- d. *Competition:* Our current competition is the mMAP device. This product costs approximately \$2,800.

Appendix B: References

1. Emborg, Marina E., M.D., Ph. D. Personal Communication, 2006.
2. Emborg, Marina E. Evaluation of animal models of Parkinson's disease for neuroprotective strategies. *Journal of Neuroscience Methods* 2004; 139: 121-143.
3. Grondin, R., Wang, A. monkey Movement Analysis Panel (mMAP). Anatomy & Neurobiology and MRI center, University of Kentucky. 29 June 2000.
4. Wikipedia: The Free Encyclopedia. "Bradykinesia." 22 October 2006. <<http://en.wikipedia.org/wiki/Bradykinesia> >
5. Wikipedia: The Free Encyclopedia. "Hypokinesia." 22 October 2006. <<http://en.wikipedia.org/wiki/Hypokinesia/>>