

# **Engineering World Health: Aspirator**

Nick Harrison, Communications  
Jonathan Meyer, BWIG  
Lucas Vitzthum, Leader  
Fan Wu, BSAC

BME 200/300  
Department of Biomedical Engineering  
University of Wisconsin-Madison  
December 12, 2007

**Advisor:**  
**John Webster, Ph.D, Professor**  
*Department of Biomedical Engineering*

**Client:**  
**Bonnie Tompkins, M.D.**

## **Abstract**

---

*Medical aspirators are suction devices used to remove mucous and other bodily fluids from patients. Many developing world hospitals do not possess aspirators because they cannot afford or repair the current devices on the market. The goal of this project is to create an inexpensive, locally repairable, and electricity independent alternative to current medical aspirators. The design should provide the broadest range of possible uses for developing world hospitals. The end result of this work is to produce a detailed, easy to read set of instructions that includes how to build, test, and operate the device.*

<b>Table of Contents</b>	<b>Page</b>
<b>Abstract</b>	<b>2</b>
<b>Table of Contents</b>	<b>3</b>
<b>Problem Statement</b>	<b>4</b>
<b>Background Information</b>	<b>4-5</b>
<b>Current Devices</b>	<b>5-6</b>
<b>Design Constraints</b>	<b>6-7</b>
<b>Previous Design</b>	<b>7-11</b>
<b>Testing and Results</b>	<b>11-13</b>
<b>Three Major Improvements Needed</b>	<b>13-18</b>
<b>Final Design</b>	<b>19-21</b>
<b>Cost and Availability</b>	<b>21-23</b>
<b>Testing</b>	<b>23-24</b>
<b>Future Work</b>	<b>24-26</b>
<b>Conclusion</b>	<b>26-26</b>
<b>References</b>	<b>27</b>
<b>Appendix A: PDS</b>	<b>28-29</b>
<b>Appendix B</b>	<b>31</b>

## **Problem Statement**

---

Engineering World Health (EWH), a nonprofit organization through Duke University, has asked for help in designing an inexpensive medical aspirator that can be built and repaired from locally available parts and expertise for developing world hospitals. The device must be able to function semi-autonomously off electricity since a constant electric power supply will not always be available. Developing hospitals will likely be able to afford only one aspirator, so the design must function under the broadest range of applications possible. Pressure and flow rate ranges should be comparable to current medical aspirators on the market. Ultimately, EWH requires a detailed set of instructions for the construction, testing and use of an aspirator that can be built completely from locally available resources that will meet all the relevant criteria for functioning in a developing world hospital.

## **Background Information**

---

Aspirating equipment can be found in almost any hospital, ambulance, or dental clinic in the United States. A medical aspirator is simply a suction device used to remove mucous, blood, or other bodily fluids from a patient (**Figure 1**).

The apparatus generally includes disposable suction tips and a removable collection receptacle. This device is a necessary tool in dental practice, liposuction and most surgical procedures.

Depending on their exact function, aspirators are generally powered by 120V AC outlets, batteries, or a combination of both. The size and portability of the device are also determined



**Figure 1: Tip of surgical aspirator.**  
Source:  
<http://www.valleylabeducation.org/esself/Pages/esself23.html> 4

by its application. Sizes can range from 5.17 kg battery powered hand held devices to 31.75 kg stationary surgical units (Gomco Suction Equipment, 2006). Aspirators currently on the market are designed for use in modern, state of the art medical environments. Differences between modern and developing hospitals render these models impractical for use in third world countries.

Third world hospital conditions are radically different from their modern American counterparts. Electricity is spotty at best for developing world hospitals and therefore equipment cannot depend on a constant supply of electricity. Trained medical professionals are in short supply, requiring devices to have the simplest user interface possible. Limited space is another concern, as most rooms are overcrowded with patients, staff, and equipment (Hill D 2005).

## **Current Devices**

---

There are many medical aspirators on the market today with a wide variety of functions. In the \$500-600 price range, Gomco® provides a line of portable aspirators (Models G180, 405 & 300) that use diaphragm compressors to create vacuum ranges from 0-600 mmHg and flow rates of 30 liters per minute (lpm). Dimensioned at 30.5x22.9x30.5 cm, these devices weigh around 6.58 kg. Specialized stationary aspirators are available for uterine, thoracic drainage, endocervical, and dental operations. Most are powered via 120V AC current and range in weight from 22.7-31.8 kg. Thoracic and thermotic drainage pumps operate under low pressure and low flow conditions (0-50 cm H<sub>2</sub>O, 2.3 lpm) to regulate drainage levels in postoperative care. Endocervical

aspiration alternatively requires high pressure ranges (600 mmHg) and high flow rates (20-30 lpm) for brief intermittent use (Gomco Suction Equipment, 2006).

All of these designs, however, are inaccessible to a developing world hospital for several reasons. The most obvious limitation of these devices is their price; even the cheapest models exceed EWH's projected \$100 budget. In addition, the specialization of current devices provides another budgeting concern. Most aspirators on the market are designed for a very specific function. A hospital that can only afford a single aspirator would need the broadest range of applications possible. Finally, these devices cannot be repaired with locally available parts and expertise. Advanced circuitry and specially manufactured parts render these devices irreparable in developing world hospitals.

## **Design Constraints**

---

Engineering World Health provided only a couple of constraints to follow and left the rest of the design quite open-ended, creating the need to establish additional guidelines. The biggest focus of the aspirator design is that it needs to be constructed entirely from locally available materials in third world countries. These materials can include anything already on hand in the hospitals, as well as anything that can be obtained from the surrounding environment, such as car batteries, simple motors, and tubing. The design must include autoclavable suction tips for easy sterilization. The final goal of this semester is to produce a working prototype for less than \$100 and a set of detailed instructions, as specified by EWH. Since the apparatus will be used in a hospital setting, the final product must be safe for sterile use in the operating room. The

final device should not rely solely on electric power, due to its inconsistent availability in third world countries.

Additional design constraints were also created for the vacuum range and flow rate. After researching various current aspirators on the market, it was agreed the design should have an adjustable vacuum range of 0–550 mmHg below the standard sea level atmospheric pressure of 760 mmHg. The maximum flow rate of material and liquids through the tubes should be adjustable from 0-30 Liters per minute (lpm). These specifications are based off an aspirator (Model-IRC1135) produced by Medical Supply 4U (Aspirator Suction Machine, 2007). A full product design specification is available in *Appendix A*.

## **Previous Design**

The main components of last semester’s design include a 12 V car battery, a fan motor, a diaphragm system, a pair of one-way valves, a fluid collection chamber, and tubing with an autoclavable tip (**Figure 2**). The battery provides power to turn the fan

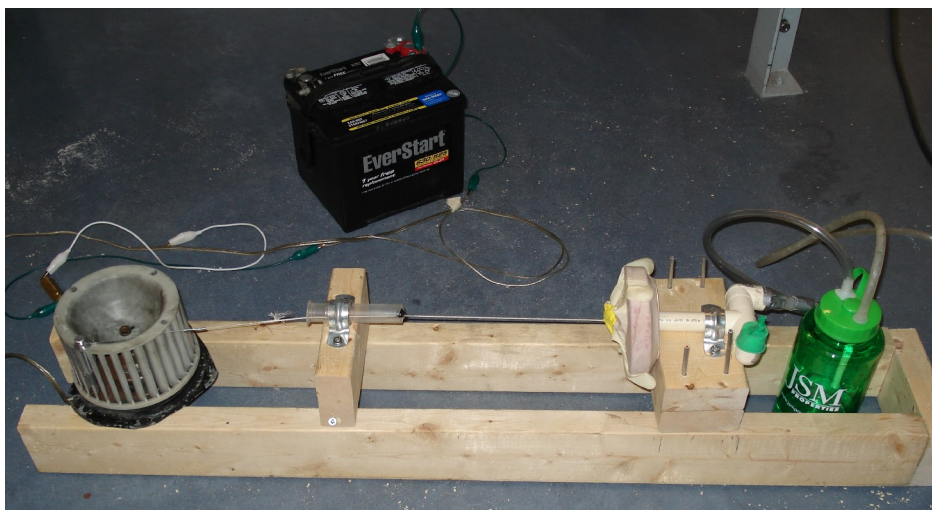

**Figure 2: Overall Design**

motor. The radial motion of the fan is converted to linear motion by means of a string. This linear motion oscillates the diaphragm,

creating a continuous cycle of air flow into and out of the diaphragm compartment. The air flow into the one way inlet valve creates suction in the attached tubing system. Fluid can then be drawn in through the autoclavable suction tip and collected in the collection chamber.

Due to inconsistent electricity in developing world hospitals, the power source for the design runs independent of AC power. The 12V DC car battery provides enough energy to power the fan motor and allows the aspirator to be run for at least 2 h. without recharging. When the battery dies, it can be recharged using another car or other various ways if AC happens to be available. The car battery can easily be salvaged from an abandoned vehicle.

Typical wires complete a simple circuit consisting of the battery, a 2 Ω power resistor, and a fan motor in series

(Figure 3). The power resistor decreases the power reaching the motor and is

necessary to slow the rotational velocity. In the third world countries, the power resistor can be replaced by a system of light bulbs or other objects that can act as power resistors.

The motor speed will vary depending on how these are hooked up. Once the circuit is connected, the fan motor runs at a more manageable speed. Also, by being able to change the number of light bulbs used in the circuit, this feature allows the users to vary the amount of resistance and thus optimize the speed of the motor to vary the rate of aspiration.



**Figure 3: Battery and Power Resistor in Series**



The fan motor is salvaged from the heater blower of a car. Any other motor that provides the same circular rotation would also work, as long as it is able to pull on the diaphragm with enough force. A bolt and washer is glued, tied, and/or taped through the outer rim of the fan attached to the gear of the motor (**Figure 4**). Tied to the washer is an approximately 70 cm long string. The washer allows free rotation and prevents the string from coiling up and breaking.



**Figure 4: Fan Motor**  
Bolt, washer, and string attached through outer rim of fan

The string is fed through a syringe casing that is mounted at the same height as where the string is tied to the washer. The syringe is approximately 1/3 of the way to the diaphragm system. The syringe refines the motion of the string, eliminating unnecessary side-to-side motion and increasing the linear pull needed for the diaphragm. The other end of the string is tied to a rubber balloon which is part of the diaphragm system.

A cylindrical lid (~8 cm radius) from a food container is fitted around the lone end of one inch diameter, T-shaped PCB pipe, resulting in the base of the diaphragm. A

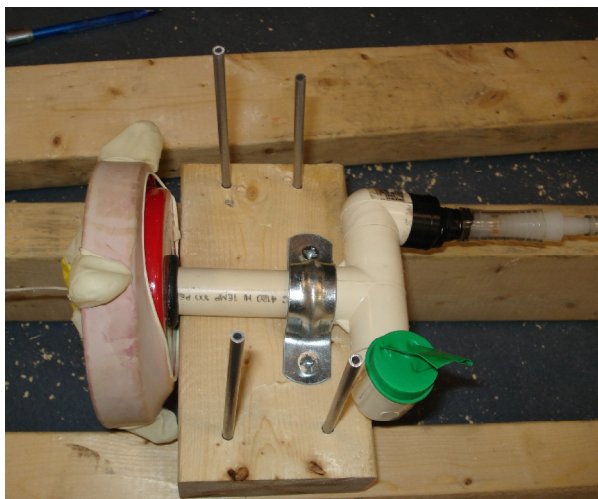

**Figure 5: Diaphragm and Valves**  
Left: diaphragm; Right: balloon output valve (bottom), black inlet valve (top)

thick rubber balloon is stretched over the lid to create the diaphragm and the string is tied to the tip. A layer of rubber glove is super-glued to the balloon and over the string for added support (**Figure 5**). The center of the

diaphragm (where the string is tied) should also be the same height as both the syringe and the washer-string connection to prevent friction and wear on the string.

The outlet one-way valve is the stem of a balloon glued half shut and stretched over one end of the PCB pipe. The inlet one-way valve is a check valve obtained from the bulb of a sphygmomanometer. This is located in the tubing adapter attached to the other PCB pipe opening. From this tubing adapter at the input check valve, a tube is connected which leads to the collection chamber (**Figure 5**).

The collection chamber shown in **Figure 6** is an air tight, hard plastic water bottle (e.g. Nalgene). Holes were drilled into the lid and fitted for tubing adapters. Attached to the air/fluid intake tube adapter is a pen shell or other long cylinder object, such as a straw, that will direct aspirated fluid to the bottom of the collection chamber and thus prevent liquid uptake into the diaphragm system.

Finally, the design uses a pipette tip as the autoclavable suction tip (**Figure 6**). The tip is cut so a wider opening can take in water at a faster rate (see testing). While the pipette tip is plastic, it is a hard plastic that can withstand the high temperature and pressure of the autoclave machine.

The entire system is mounted on a wooden frame to hold each of the individual components in its correct position in relation to the other parts. The placement of the motor and diaphragm should be such that it maximizes the amount of air flow created by



**Figure 6: Collection Chamber, Tubing, and Autoclavable Tip**

system (determined through trial and error). The collection chamber is not permanently attached to the frame. This allows it to be removed, emptied, and cleaned. The battery is also not attached to allow easy removal for recharging. The entire system can be placed on a cart where it can be easily moved throughout the operation room. Ideally, the cart would be as low to the ground as possible. This would decrease the amount of obstruction and allow easy storage under tables, beds, etc. As an added benefit, this will maximize the flow rate of the aspirator by using gravity to its advantage.

Safety is the most important aspect of any medical device. It is important that all pieces that may come into contact with patients have the ability to be sanitized. The tip used to aspirate is completely autoclavable, a process used to sterilize medical equipment.

Because of the simple user interface of the aspirator, it is easy to use and thus minimizes the possibility of a user-related error. In addition, construction of the device is relatively simple and can be completed in a timely manner.

## Testing and Results

Evaluation of the prototype was done by running tests on the device to measure its performance. Tests were completed that measured two values: the liquid flow rate and the vacuum pressure. Liquid flow

**Table 1:** Flow rate testing results

<b>Large Tip</b>					
trial	Liters	Seconds	Flow (L/s)	Flow (L/m)	
1	0.54	20	0.027	1.62	
2	0.5	20	0.025	1.5	
3	0.52	20	0.026	1.56	
4	0.54	20	0.027	1.62	
5	0.56	20	0.028	1.68	
6	0.52	20	0.026	1.56	
Mean			0.0265	1.59	
SD			0.001049	0.062929	
SE			0.000428	0.02569	

<b>Small Tip</b>					
trial	Liters	Seconds	Flow (L/s)	Flow (L/m)	
1	0.28	20	0.014	0.84	
2	0.32	20	0.016	0.96	
3	0.32	20	0.016	0.96	
4	0.34	20	0.017	1.02	
5	0.36	20	0.018	1.08	
6	0.3	20	0.015	0.9	
Mean			0.016	0.96	
SD			0.001414	0.084853	
SE			0.000577	0.034641	

rate represents the volume of liquid that can be aspirated over the time it takes to do so (usually measured in liters/min, or lpm). This value is important because it corresponds to the maximum amount of bodily fluid that could be evacuated in a period of time, such as how fast a certain amount of blood could be removed during a surgery.

To measure the liquid flow rate of the aspirator, the tip was submerged in an open container filled with water. Time trials began at the start of suction, just after the battery was connected to the aspirator. After 20 s. had passed, the volume of liquid aspirated was measured by the amount of water that accumulated in the collection chamber. The water bottle used as the collection chamber was marked with levels of 100 mL, thus allowing analytical measurement of liquid to increments of 20 mL. Precautions were taken throughout the testing to ensure the pool of water was level with the collection chamber, as to eliminate the possibility of a siphon effect influencing the flow rate.

Twelve trials of 20 s. each were run to measure the liquid flow rate. Within these twelve trials, six were done with a small pipette tip and six were performed with a larger pipette tip. Results are shown in **Table 1**. The average flow rate of the small tip was just

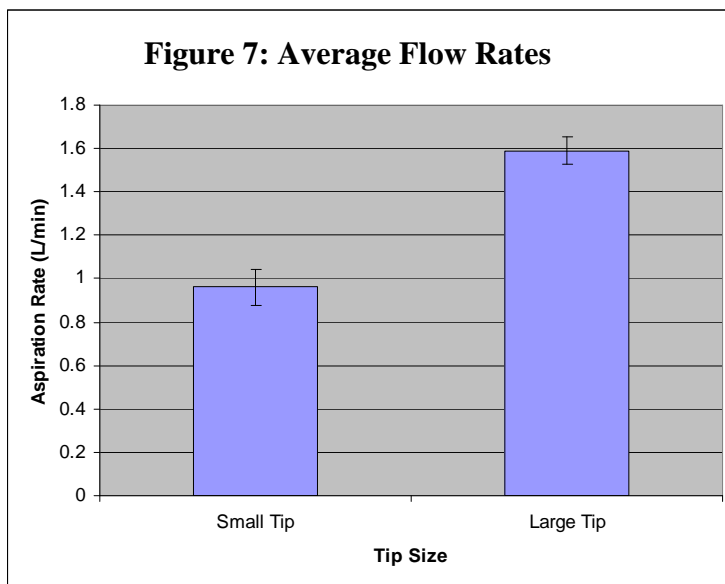

less than one liter per minute (0.96 lpm), while the large tip averaged over a liter and a half per minute (1.59 lpm), as shown in the graph of **Figure 7**. Values were relatively consistent within each given set of trials.

The other value tested was the amount of vacuum pressure generated by the aspirator. To measure this, the aspirator tip was connected to a pressure manometer with the device running. A vacuum of 3.0 inHg was created. This value is equal to about 76 mmHg below standard atmospheric pressure. While the results testing are less than the target values established in the design criteria, they represent an excellent proof of concept, especially for a device built completely from salvaged materials with no machining or advanced fabrication. In addition, even operating with maximum values approximately 1/10 those of commercial aspirators, this design is still effective. The flow rate of 1.51 lpm still moves a substantial amount of fluid and as such would be useful in a hospital setting.

### **Three Major Improvements Needed**

---

Although the original prototype was functional, the following three major areas required improvements before the final instructions were written up: the vacuum source, the one-way valve design, and modifications for hospital integration.

#### **Improvement 1: The Vacuum Source**

The car battery and the fan motor both satisfy the design constraints and are relatively efficient, so the two major components of the vacuum source needing improvements were the diaphragm attachment mechanism and the diaphragm itself.

Last semester, the diaphragm was attached to the motor by a string. A string can only exert tension force and not compressive force, so during half of the oscillation, it simply releases the diaphragm and doesn't do any work. This mechanical inefficiency could be improved by replacing the string with a rigid arm that can both pull and push the

diaphragm. As shown **Figure 8**, a rigid arm system consists of two members

connecting the motor to the diaphragm. The pin joints and the roller supports help to convert the

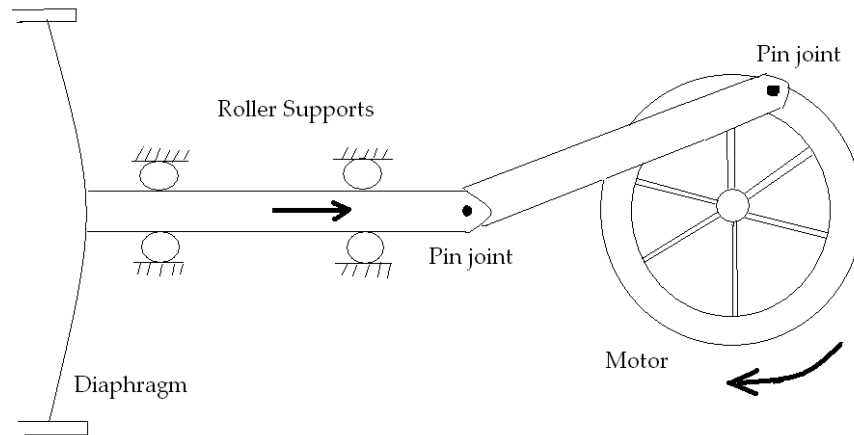

**Figure 8: A Sample Rigid Arm Design**

radial motion of the motor to the linear displacement of the diaphragm. Possible materials for the arms include clothes hangers, a car antenna, or other easily obtainable rigid materials.

As for the diaphragm, the original rubber balloon design was not only thin and weak, but also deteriorated over time. To improve the diaphragm system, two options were developed. The first option was to use a different diaphragm material. Tire inner tube rubber is one of the best alternatives because it is thicker and therefore more stable and more durable. It is also widely available in a third world country setting. Building a new diaphragm out of inner tube materials could result in a more consistent and reliable vacuum generated over time than the previous design.

A second option for improving the diaphragm system was to replace the diaphragm with a device like a syringe, with a solid member moving back and forth inside a tube to displace air and create the vacuum. Although this design was initially viewed with suspicion because of its greater mechanical intricacy, it is more durable and easier to maintain than a diaphragm system. It can also be more easily modified to

maximize airflow and vacuum. Thus, it was chosen over the original diaphragm-based system.

### **Improvement 2: The Check Valve Design**

Another aspect of the previous aspirator design needing improvement was the check valve design. Two different valve designs were used in the previous design. The valve at the entrance of the vacuum chamber was taken from a bulb sphygmomanometer. The valve at the exit of the vacuum chamber was constructed from the neck of a balloon which would collapse in on itself to block reverse airflow.

Although these valves were functional, they had two disadvantages. The primary disadvantage was that the sphygmomanometer valve was impractically expensive; it required the purchase of an entire sphygmomanometer to get only one valve. The second disadvantage was that the balloon valve was inconsistent. The balloon rubber was too flexible and wouldn't always form a seal. Thus, a valve design was needed that would be both inexpensive and efficient. After discussing different valve designs with Dr. John Webster, the following three valve designs were developed: the ball valve, the single-flap valve, and the double flap-valve.

The first design considered was the ball valve, which consists of a small ball (such as a marble or a ping pong ball) inside of a funnel, with either a rubber ring or a coating of grease acting as a seal between the funnel and the ball. In this design, the ball is lifted by outgoing air and then falls back into place, blocking reverse airflow. This design has several disadvantages. First, it can only function if the funnel is in an upright position, making it difficult to use for the entrance valve. Second, it is susceptible to failing if the aspirator is bumped or tipped while in use. Finally, it is difficult to form a

tight seal between the ball and the funnel. When a rubber ring is used, it deforms slightly when attached to the funnel, allowing air around the ball. When grease is used, it slows the ball down, keeping it from falling back into place fast enough.

The second design considered was the double-flap valve consisting of two flaps of rubber held together over a rigid ring. It operates on the same principle as the previously used balloon valve; the flaps open to allow air through, and then collapse in upon each other to block reverse airflow. The difficulty with this design is that it is difficult to cut the pieces of rubber to the right shapes and sizes and attach them in the right orientation to get a tight seal. Thus, although this design is functional, preference was given to a simpler design.

The third and final design considered was the single-flap valve, which consists of a single piece of rubber glued to the top of a rigid ring to form a flap. The flap lifts to allow air to pass through, and then snaps back into place, blocking reverse airflow. If the rigid ring is glossy (like the lid of a metal food can), the valve readily forms a tight seal.

This single-flap was chosen as the final valve design because of its advantages over the other designs. It is much better than the ball valve design because it works faster, doesn't need to be held upright to function, and it is less expensive. It also has two advantages over the two-flap valve. First, it is simpler to construct, which is important because it needs to be able to be constructed with limited expertise from a set of instructions. Second, it is smaller, allowing it to fit easily inside a pipe and thus be used for both the entrance and exit valves.



### **Improvement 3: Hospital Integration**

Several aspects of the design related to hospital integration needed to be changed before third world hospitals could implement the design. The first was an overall reduction in size. Last semester's design was too large to feasibly be used in a hospital or operating room setting. The overall length can be reduced by decreasing the distance between the diaphragm and fan motor with the proposed two-member, rigid arm design. In the original string system, a larger distance was needed to prevent wear on the string where it was fed through the syringe. The rigid arm design is shorter because a rigid member can be restricted to a linear motion in a smaller amount of space without breaking. Wearing down of the rigid member will not be as much of an issue as the string breaking. Also, the overall size is reduced by decreasing the size of the frame that supports the individual components. In the end, however, the design will not be as compact as current aspirator models due to a lack of technology and machining ability in the third world countries.

Another area that needed to be improved was safety. The previous design had the wires, battery, fan motor, and diaphragm all exposed. All of these components should have been covered in a portable cart. In addition to preventing injuries to people, this cover would be useful in protecting the aspirator from damage. Any liquid spillage or mechanical damage could result in harm to both the aspirator and anyone in the room. A cardboard cover would be easy to shape, but not sturdy or easy to clean. A hard plastic cover would provide a good barrier between the inner workings of the aspirator and anyone using it and would also be easy to sterilize.

A developing world hospital may only be able to afford one working aspirator. Therefore, the aspirator needs to be easily transportable from one room to another. A simple push cart would work, assuming the aspirator is small enough to fit. If this is not available, a specialized cart could be constructed to fit the aspirator components.

A simple aspect of the design that was missing was an on/off switch. In the last design, the fan motor was turned on and off by manually attaching and removing the wires directly from the base of the motor. Not only is this approach slightly dangerous, the wires can be difficult to connect to the motor. A solution to the problem that was considered was to insert an on/off switch into the circuitry. This switch can then be attached to the cover, allowing the user to easily turn the aspirator on and off without having to get near the motor or battery.

Finally, pressure regulation would be a useful application in the operating room. Depending on the procedure, the aspirator may need to slowly drain blood from the patient or it may need to rapidly suction large amounts of fluids. One way to accomplish this would be to insert a bleed valve in the tubing between the collection chamber and the inlet valve. Opening or closing the bleed valve would alter how much air is being pulled in by the diaphragm system, and in effect change the suction rate. Another way to alter how much air is being pulled into the system would be to alter the rotational speed of the motor. Different resistances can be applied to the circuit to speed up or slow down how fast the motor rotates, thus altering how many times the diaphragm is pulled and compressed. Since the air flow depends on the displacement of the diaphragm, the amount of air pulled into and pushed out of the system will change depending on how fast the motor rotates.

## Final Design

---

The final design for this semester is an improvement of the previous design in the three areas previously highlighted: vacuum generation, check valves, and hospital integration. This design uses two rigid arms to convert the radial motion of the fan motor into linear motion via a restricted pin connection. The pin is fitted into a slit cut into a piece of wood. One arm rotates with the motor while the other simply moves back and forth due to the pin restriction. The linear motion of the rigid arm powers a piston

**Figure 9: Piston/motor unit with collection chamber** which displaces air through  
Shown on top of sterile cart



one of two check valves. The inlet check valve is connected to a collection chamber and an autoclavable suction tip via Tygon® tubing. The 12 V car battery (not pictured),

collection chamber and piston/motor unit can fit in a compact cart, making the device both mobile and sterile (**Figure 9**). Detailed instructions of how to construct and run the prototype are included in **Appendix B**.

A standard 12 V battery is used to power the fan blower motor. AC power, a mechanical generator, or an automobile can be used to recharge the battery. Alligator clips connect the battery terminals to the speaker wire. The other end of the speaker wire is fixed to the motor. One connection point of wire and one end of an alligator clip can be left outside of the cart to function as the on/off switch for the device.

The radial motion of the fan motor is converted into linear motion. This is accomplished by connecting a bolt on the outer radius of the motor to one end of a bolt that functions as a pin. The connection is made using coat hangers that can be shaped as needed to wrap around the bolts, but are rigid so that they don't deform when the aspirator is run. The pin is fit inside of a straight slot cut out of a piece of wood. This slot is responsible for keeping the second rigid arm moving in a linear direction. The other end of the slotted bolt is attached to the piston head via this second rigid arm (again made from coat hangers). The piston's movement is constricted to a purely linear path with a stroke range equal to the diameter of the motor (**Figure 10**). This rigid arm design greatly improves the

durability and running life of the device by removing the fragile string and rubber diaphragm of the previous design. The design also greatly reduces the size of the

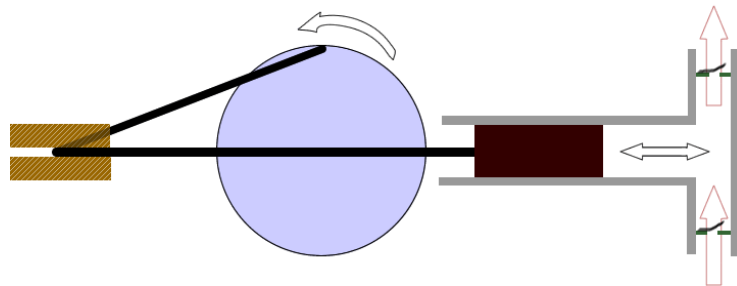

**Figure 10: Overall Concept**  
Diagram illustrating radial and linear movement of motor and piston system

aspirator due to the inversion of the rigid arms over the motor.

Linear oscillation from the piston head inside the PVC pipe causes a displacement of air that flows through one of two one way valves. The valves are oriented such that when the piston is pushing air in one direction, one valve opens while the other is pulled shut. The one way valves used this semester show significantly less deformation than the previous balloon valves, thus increasing the efficiency of each valve.

One end of the Tygon® tubing fits inside a PVC cap attached to the inlet check valve side and the other end is attached to the collection chamber. The tubing is flexible, yet rigid enough to resist collapsing when a vacuum is established. An autoclavable pipette tip is attached to the end of another piece of tubing, with the other end also attached to the collection chamber. Air and fluid is drawn in at the pipette tip, with fluid gathering in the collection chamber. The dead space in the collection chamber also serves the purpose of damping the fluctuating air flow from the piston into a steady vacuum.

All components of the device can be placed inside of an enclosed mobile cart. Ideally the cart should be made of plastic or metal so that it may be easily sterilized. Carpeting, foam, or other insulation can be wrapped around the cart to insulate noise created from the aspirator. The collection chamber should be placed on the bottom of the cart to maximize the siphon effect from gravity, increasing the flow potential.

## **Cost and Availability**

---

The cost of this semester's prototype is estimated at \$52.74 for parts purchased in the U.S. (**Table 2**). This is considered to be a high estimate, as many of the parts used can be salvaged free of cost. The simplicity of the design allows parts to be readily exchanged, depending on what materials are available in the particular third world country. The table below includes a list of possible materials that would suffice for each part of the aspirator and a possible third world source. This will ensure the hospital is purchasing as few parts as possible for the construction of the device. Depending on

what parts can be salvaged; a total cost of \$20-30 is a practical estimate of actual cost, which is well under EWH's \$100 budget limit.

The design also meets EWH's requirement that all tools and skills necessary for the construction of the device are available in a 3<sup>rd</sup> world country. The only tools required for building the aspirator are a hammer, nails, and glue (screws and screwdriver may be preferred if available). No special training or expertise is required at any step of the aspirator's construction. Any wiring involved in the construction of the aspirator will be explained in the instructions and requires no significant understanding in electronics or circuitry. A hospital employee involved with construction or maintenance could easily assemble this device with standard, readily available tools.

**Table 2: Parts Table**

Shows each component of the final design, its price, and possible 3<sup>rd</sup> World source

<b>Part</b>	<b>Cost</b>	<b>3<sup>rd</sup> World Source</b>
<b>Duct Tape</b>	\$2.50 Source: Home Depot	Household item
<b>PVC Pipe</b>	\$1.09/0.3 m x 0.6 m = \$2.18 Source: Home Depot	Plumbing equipment
<b>PVC Joints</b>	\$2.49	Plumbing equipment
<b>Tire Inner Tube</b>	\$2.50	Salvaged Bike/automobile
<b>DC Fan Motor</b>	\$5.00 Source: Moemart Salvage	Salvaged automobile
<b>12 V Battery</b>	\$20 Source: Moemart Salvage	Salvaged automobile
<b>Pipette Tip</b>	\$0.04 Source: Fisher Catalog	Hospital lab
<b>Plastic Bottle</b>	\$0.75 Source: Ax-man Surplus	Household item

<b>2x4 Lumber</b>	\$.80/0.3 m x 1 m = \$2.40 Source: Home Depot	Natural environment Abandoned building
<b>Nails/Screws/ Bolt</b>	\$.20 x 8 = \$1.60 Source: Home Depot	Abandoned building Construction material
<b>Water Bottle</b>	\$4.00 Source: Walmart	Household item
<b>Tygon® Tubing</b>	\$1.09/0.3 m x 1.8 m = \$6.54 Source: medicalsupplyco.com	Operating room Salvaged automobile
<b>Soup Lids</b>	\$0.25	Household item
<b>Graphite Lubricant</b>	\$1.99 Source: Home Depot	Graphite pencil
<b>Wire Coat Hangers</b>	\$0.25x2 = \$0.50 Source: Walmart	Household item
<b>Total</b>	<b>\$52.74</b>	

## Testing

The prototype was tested for both air and liquid maximum flow rates. Air flow was tested using a clinical flow meter and was found to be approximately 12 lpm. Liquid flow rate was determined by measuring how much water was displaced in thirty second intervals. The average liquid flow rate was calculated at approximately 1.5 lpm. The results are shown below in **Figure 11**.

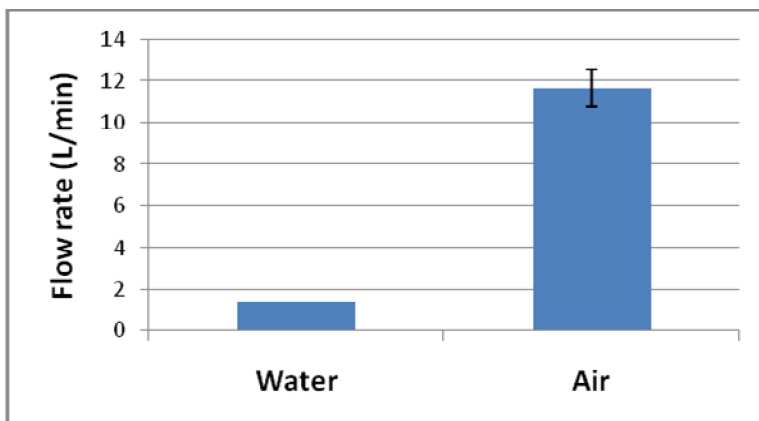

**Figure 11: Flow rates**  
Graph showing flow rate (L/min) produced by aspirator for liquid and air.

The aspirator was also run for 10 minute intervals continuously, and showed no visible signs of wear or fatigue. To further test the durability, the aspirator will be run for two hour intervals, with flow rate tested and compared before and after each trial. Further testing, including vacuum established and motor/suction power ratios, is also needed to completely evaluate the prototype.

## **Future Work**

---

Although the current design is able to consistently draw in around 1.5 lpm liquid and 12 lpm air, it seems the current design has potential to do more with a few modifications. If the device is able to move more air through the system, it is likely that both flow rates will increase. There are a few options available that wouldn't be too difficult to change in the current design. One option is to increase the diameter of the piston (and vacuum chamber). This would allow more air to be moved in and out of the system with the same stroke length from the piston. Increasing the size of the tubing and holes for the one way valves may also be necessary. Currently, the smaller diameters of these components may be limiting what the aspirator can do. Another option is to increase the stroke length. Again, more air would be drawn in and pushed out on each stroke. A combination of all these ideas will likely improve the flow rates for the aspirator.

A possibility that would require more construction and possible redesign is the addition of another piston system. Ideally, this would double the flow rate. The second piston could be added on top of the current piston and the pin length extended. However,



this might cause too much torque on the pin on each stroke. A more likely scenario would be to add the second piston opposite the current piston. Although this would increase the size of the aspirator, the benefits of increased flow rate may outweigh the size inconvenience.

Once the flow rate is maximized, it may be beneficial to be able to limit the flow rate if needed. One way to do this would be to input some power resistance into the wiring between the battery and motor. In the third world, this could be done by using a system of light bulbs or some other material that would act as a power resistor. This would limit the amount of power delivered to the motor and decrease its rotational speed. Limiting the rotational speed decreases how much fluid or air can be drawn into the system. Another option is to insert a bleed valve into the inlet valve tubing or vacuum chamber. This would allow the operator to open or close the valve as desired and control the air flow through system. Opening the valve would allow air to escape and likely decrease the efficiency and flow rate of the aspirator.

A final area of improvement would be to reduce the noise produced by the aspirator. Although the client did not deem this to be much of a problem, the quieter the machine, the better. Currently, the main source of noise is the pin connection hitting the wooden piece that restricts its motion when the piston switches direction. This could be reduced by applying a material (cloth/rubber) to the wood, as long as it does not slow the speed of the stroke due to increased friction. Also, there is noise from the washers of the pin connection rubbing on the wooden piece over the course of the stroke. Again, the application of a material such as cloth or rubber may reduce the amount of noise produced.

## **Conclusion**

---

The prototype built this semester is an excellent proof of concept for a medical aspirator that could be built and used in developing countries. The improvements made over the previous design improve the efficiency, durability, and size of that design. Although there was no significant increase in flow rates, the new prototype is a much more functional device than the previous design and has the potential (with a few modifications) to increase these flow rates. Replacing the rubber diaphragm and string with the rigid coat hanger members and piston system greatly increases the durability and operating life of the aspirator. The new mechanical design also makes the prototype more compact, making it easier to store and transport.

The current design of the prototype would be functional for low flow aspiration, as used in some surgical procedures and post-operative drainage. Improvements, however, are still needed to achieve the flow rates required for rapid aspiration. Increasing the amount of air displaced during the cycle of the motor has been identified as the easiest way to increase the maximum vacuum and flow and could be accomplished as described in the previous section. In addition, rigorous testing is needed before any hospital implementation to ensure the safety and reliability of the device. Hopefully after this testing, the device can actually be used to benefit the lives of those in developing countries.

## **References**

---

*Aspirator suction machine.*, 2007, from

<http://www.medicalsupply4u.com/prodList.asp?idCategory=112&showFilter=0&idProduct=51>

Electro surgery continuing education model. (2007). March 12, 2007, from

<http://www.valleylabeducation.org/esself/Pages/esself23.html>

*Gomco Suction Equipment & Accessories Guide*, 2006, Gomco by Allied,

From <http://www.alliedhpi.com/images/z21-00-0000.pdf>

Hill, D. (2005). *Duke engineering program improves hospital conditions in developing countries*. Retrieved 4/12, 2007, from

<http://www.dukenews.duke.edu/2005/09/DEWH.html>

*Venturi Vacuum Generators.*, 2007, from <http://process->

[equipment.globalspec.com/SpecSearch/ProductSpecs?QID=0&VID=111182&Company=2758&bcomp=2758&tid=0&ShowSort=true&SortOptions=&Pg=2](http://equipment.globalspec.com/SpecSearch/ProductSpecs?QID=0&VID=111182&Company=2758&bcomp=2758&tid=0&ShowSort=true&SortOptions=&Pg=2)

## **Appendix A - PDS**

---

### **Product Design Specification (PDS)**

#### **Engineering World Health Aspirator (November 2007)**

Lucas Vitzthum - Team Leader  
Nick Harrison - Communications  
Jonathan Meyer - BWIG  
Fan Wu - BSAC

#### **Problem Statement**

Most developing world hospitals do not possess operating suction machines. The main problems are the lack of available spare parts, the cost of a replacement unit, and dependence on consistent electricity. The objective of this project is to design and develop a set of instructions for a suction machine that can be manufactured from locally available materials (and therefore repaired using locally available materials and expertise).

#### **Client Requirements:**

- Device should run on 12 V batteries and/or manual power.
- Should provide the broadest range of applications possible.
- Device should include autoclavable suction tips.
- Must be completely manufactured from locally available materials for under \$100.

#### **Design Requirements**

##### **1. Physical and Operational Characteristics**

- a. *Performance requirements:* 0-550 mmHg vacuum, 0-30 lpm flow rate
- b. *Safety:* Must be safe for use on human surgeries and must have an autoclavable tip.
- c. *Accuracy and Reliability:* Must be able to reliably provide suction throughout an entire surgery or operation (up to 8 hours)
- d. *Life in Service:* 5 years
- e. *Shelf Life:* 5 years
- f. *Operating Environment:* Must be able to be stored and function under temperatures ranging from 4.5 to 45 degrees Celsius
- g. *Size:* Less than 0.15 m<sup>3</sup> (2/3 by 2/3 by 1/3 m)
- h. *Weight:* Less than 10 kg without battery.
- i. *Materials:* Completely manufactured by locally available parts.
- j. *Aesthetics, appearance, and Finish:* Must be easily sterilized.

##### **2. Production Characteristics**

- a. *Quantity:* Create instructions to build locally in any desired quantity.
- b. *Target Product Cost:* <\$100 in locally available materials.

### **3. Miscellaneous**

- a. *Standards and Specifications:* Must provide safe regulated pressures within developing hospital environment.
- b. *Customer:* Needs to run and power device with varying electricity and limited resources.
- c. *Competition:* Medical aspirators are widely available in developed countries. Our goal is to provide a cheap alternative that can be locally built and repaired in third world countries.

# Appendix B

## Assembly Instructions for the Fall 2007 Engineering World Health Aspirator

Submitted by:

Lucas Vitzthum

Nick Harrison

Fan Wu

Jonathan Meyer

lvitzthum@wisc.edu

nharrison@wisc.edu

fwu1@wisc.edu

jrmeier3@wisc.edu

December 12, 2007

## List of required materials.

- 1 tube of "stick'n seal" or another durable, waterproof glue.
- 1 board 56" x  $3\frac{3}{8}$ " x  $1\frac{1}{2}$ "
- 1 board  $9\frac{1}{2}$ " x  $2\frac{1}{2}$ " x  $1\frac{1}{2}$ "
- 4 washers ( $\frac{1}{4}$ " diameter hole)
- 8 nails
- 2 screws
- 2 bolts ( $\frac{1}{4}$ " diameter,  $2\frac{1}{2}$ " long), with fitting nuts.
- 1 automobile cylindrical heater fan and motor, ( $5\frac{1}{4}$ " diameter,  $4\frac{1}{2}$ " tall)

### PVC pipe:

- 9 inches of  $1\frac{1}{2}$ " diameter pipe
- 7 inches of 2" diameter pipe
- 1 "T" joint for  $1\frac{1}{2}$ " diameter pipe
- 1 cap for  $1\frac{1}{2}$ " diameter pipe
- 1 adapter for  $1\frac{1}{2}$ " to 2" diameter pipe
- 1 bicycle inner tube
- 1 rubber glove
- 2 wire coathangers
- 1 plastic bottle 2" in diameter and 6" long.
- 1 piece of duct tape 15" long
- 1 airtight jar with removable lid
- 1 tube of graphite
- 1 autoclavable suction tip with adapter to fit the tubing.

Flexible tubing ( $\frac{1}{4}$ " diameter hole) as needed

3 tubing connectors (or rubber rings that fit the outside of the tubing)

Note: This prototype was constructed using English units. This design, however, can be easily modified to accommodate metric bolt and pipe sizes.

# Assembly of the Wooden Frame: Figures not drawn to scale

Block A: (2 pieces, dimension:  $18\frac{5}{8}'' \times 3\frac{3}{8}'' \times 1\frac{1}{2}''$ )

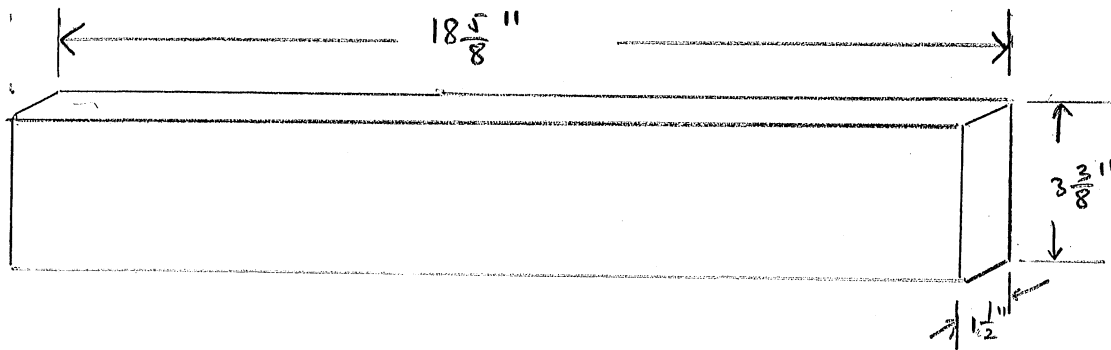

Block B: (1 piece, dimension:  $11\frac{5}{8}'' \times 3\frac{3}{8}'' \times 1\frac{1}{2}''$ )

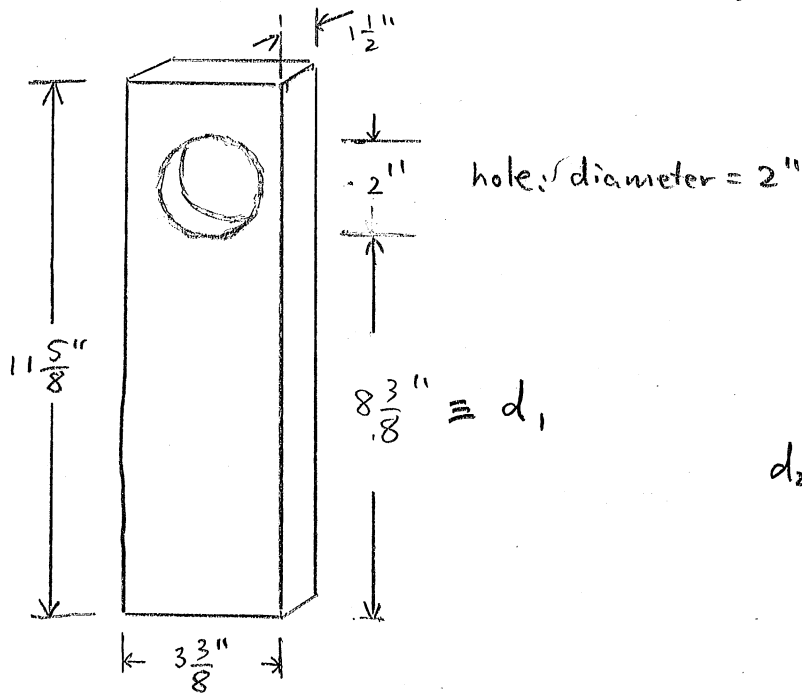

Block C  
(1 piece,  $7'' \times 3\frac{3}{8}'' \times 1\frac{1}{2}''$ )

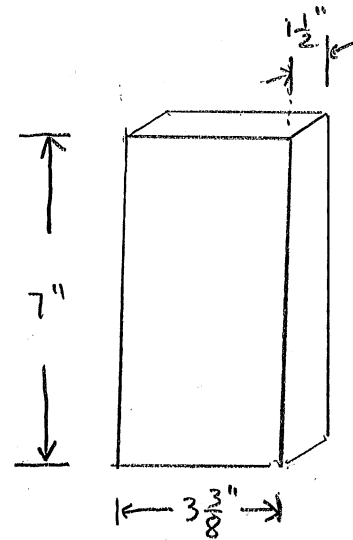

Block D: (1 piece, dimension:  $9\frac{1}{2}'' \times 2\frac{1}{2}'' \times 1\frac{1}{2}''$ )

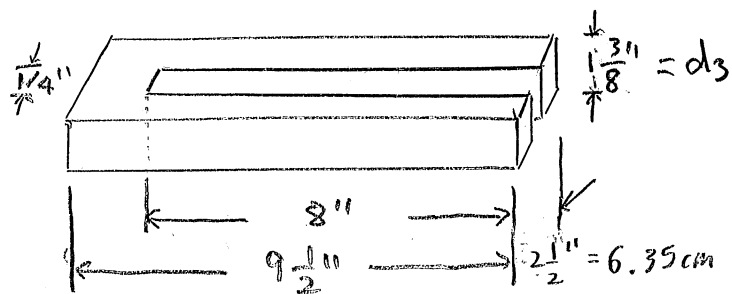

Note:  $d_1 = d_2 + d_3$  for the purpose of making the top wire horizontal, see page 3.

The cut for the slit is  $8'' \times \frac{1}{4}'' \times 1\frac{3}{8}''$ . The width,  $\frac{1}{4}''$  can be adjusted so that it is just a bit wider than the diameter of the bolt used to fit

inside; at the same time, it should be smaller than the diameter of the washers used. The length,  $8''$ , should be longer than diameter of motor.



Motor: Obtained from a fan blower inside a car

diameter:  $5\frac{1}{4}$ " height:  $4\frac{1}{2}$ "

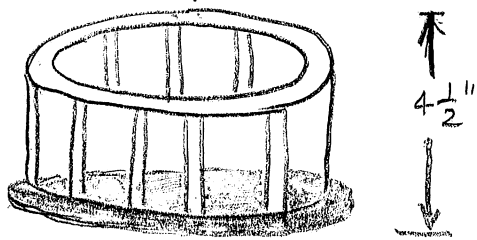

Assembly procedures:

1. Nail Block B and C in between two Block As at two opposing ends, securely

side view:

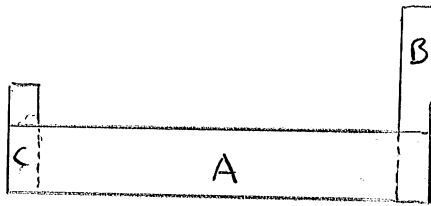

front view:

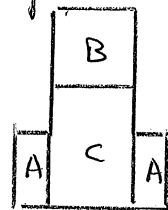

2. Nail Block D on top of Block C and then nail the motor securely on top of Block A.

side view:

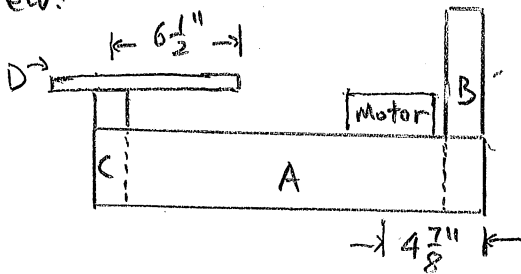

(distance measured from one end of Block A to center of the motor)

The

top view:

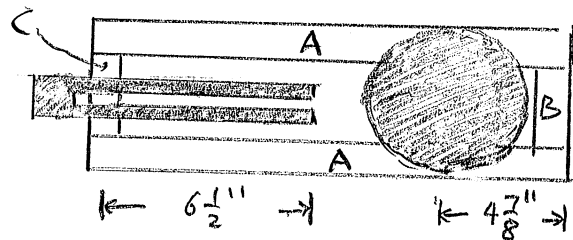

motor and Block D are shaded

# Assembly of the vacuum chamber:

## Step 1: Cut pieces

1) Prepare piston pipe

Cut a 7 inch piece of 2 inch diameter PVC pipe

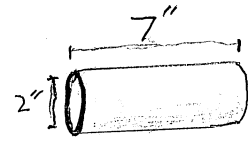

2) Prepare connection pipes

Cut three 3 inch lengths of 1 1/2 inch diameter PVC pipe

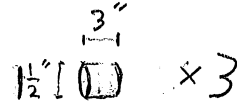

3) Get:

- A 1 1/2 inch diameter T connection

- A 2 inch  $\Rightarrow$  1 1/2 inch adapter

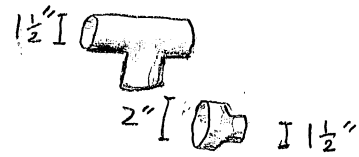

4) Drill a 1/4 inch diameter hole in a 1 1/2 inch diameter cap

SIDE VIEW

PERSPECTIVE VIEW

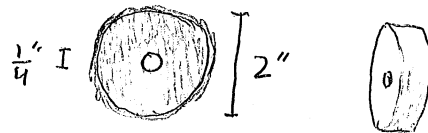

## Step 2: Make valves

1) Cut two 1 1/2 inch diameter metal discs from a food can lid, and poke a 1/4 inch diameter through the center of each disc.

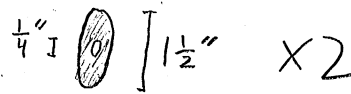

2) Cut two 1 inch diameter rubber discs from a bicycle inner tube

3) Scratch a half-moon around the central hole of each metal disc, to allow glue to more easily adhere to the metal.

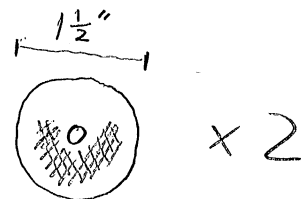

4) Glue each rubber disc over a metal disc to form a flap of rubber over the central hole

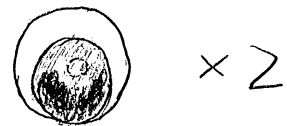

5) On the side of the metal disc opposite the rubber flap, glue a 1 3/4 inch diameter disc of thin rubber cut from a heavy-duty rubber glove. The thin rubber disc should have a hole cut in it so that it leaves the valve opening unobstructed.

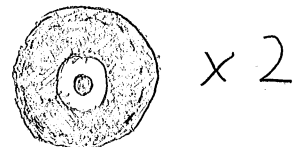

### Step 3: Assemble the valve housing

1) Insert the valves into two sides of the T connection so that they both face the same direction

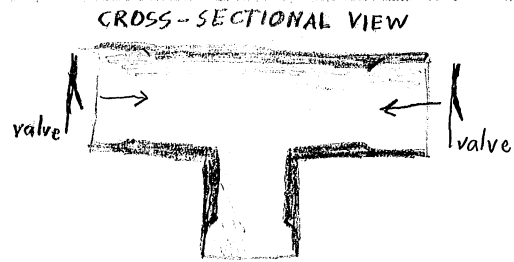

2) Insert the connection pipes into each opening of the T, locking the valves into place. Fit the cap over the inlet valve connection pipe

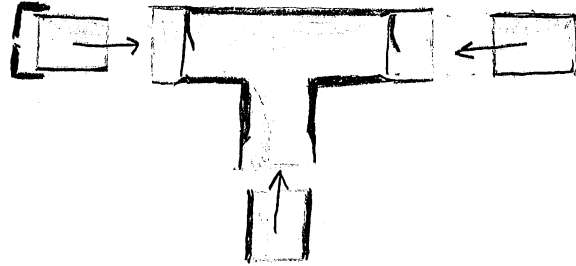

3) Fit the adapter over the base of the T

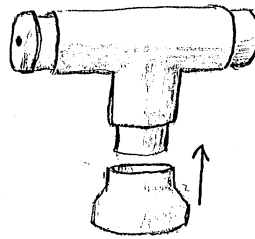

4) Fit the adapter into the piston pipe

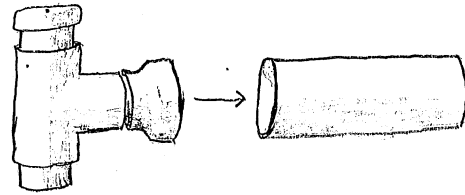

The finished vacuum chamber should look as follows:

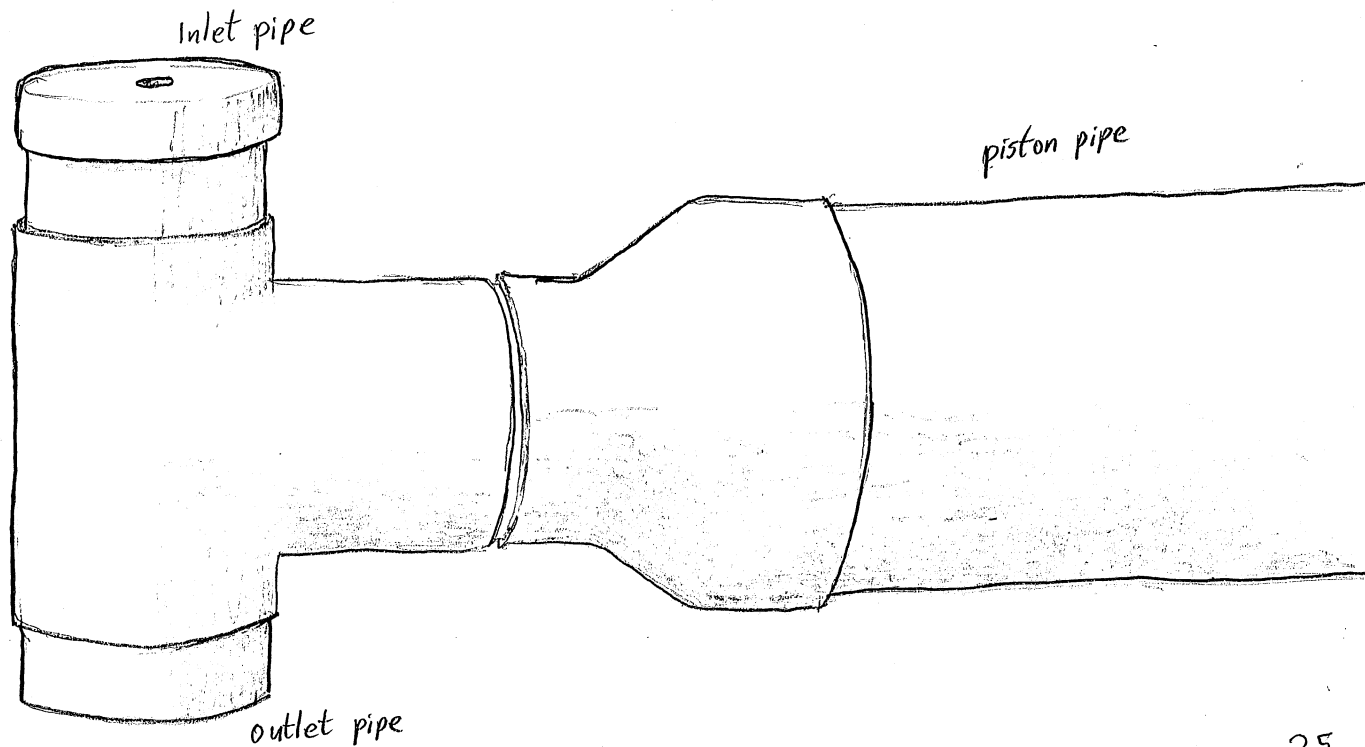

# Assembly of the piston

## Step 1: Prepare bottle

Find a plastic cylindrical bottle about 2 inches in diameter and 6 inches long

Take a  $15 \times \frac{1}{2}$  inch strip of duct tape and wrap it around the bottle  $\frac{1}{2}$  inch from its base

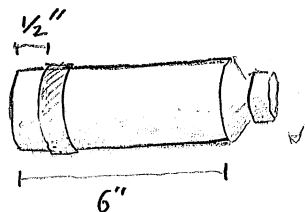
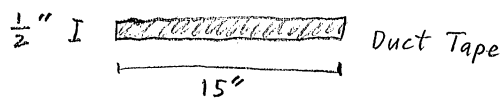

## Step 2: Attach Wire and form rigid member

- 1) Bend a piece of coathanger wire twice around the neck of the bottle, and then bend it away from the bottle, as shown:

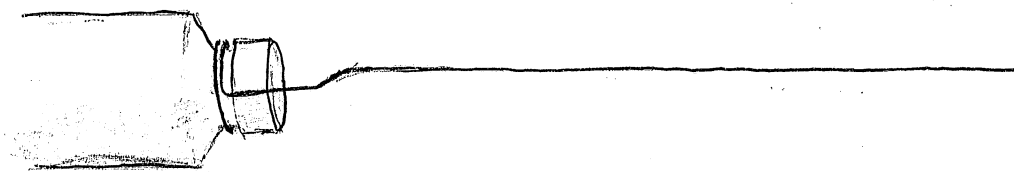

- 2) Wrap the wire  $2\frac{1}{2}$  times around a  $\frac{1}{4}$  inch diameter bolt to form a loop, leaving  $7\frac{5}{8}$  inches between the bottle and the end of the loop

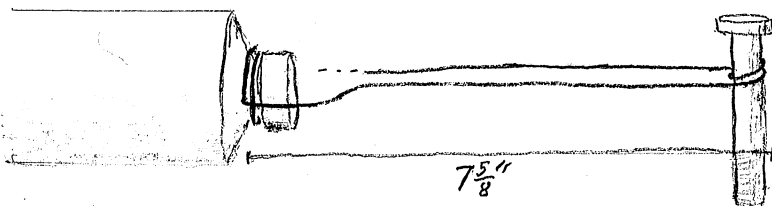

- 3) Wrap the end of the wire twice around the neck of the bottle, and cut off any excess wire. Insert a washer on the bolt between the wire loop and the top of the bolt

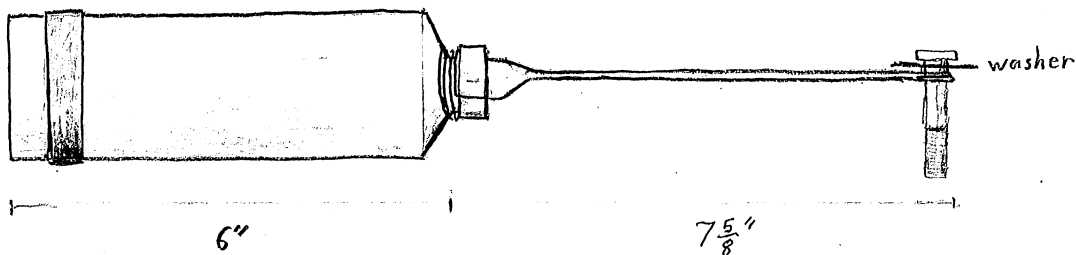

# Installation of the vacuum and collection chambers

Step 1: Install vacuum chamber

- 1) Cut three strips of inner tube rubber 3 inches  $\times$  1 inch, and stack them at the bottom of the hole in block B

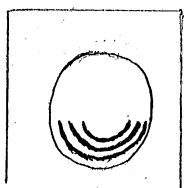

- 2) Insert the piston pipe into the hole in block B, as shown below:

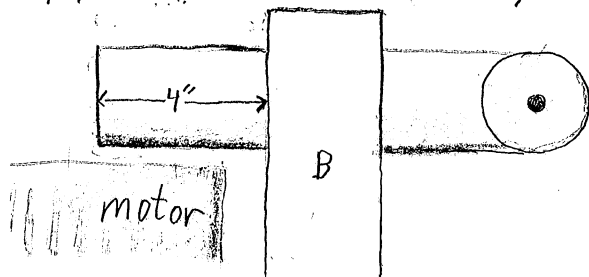

Step 2: Install the collection chamber

- 1) Drill two  $\frac{1}{2}$  inch diameter holes into the lid of an airtight jar or water bottle

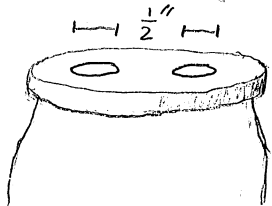

- 2) Insert a tube connector into each of the jar holes and into the inlet pipe hole in the vacuum chamber. If no tube connectors are available, rubber rings can be used instead.

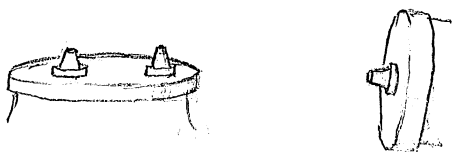

- 3) Connect the inlet pipe hole with one of the collection chamber holes with a length of flexible  $\frac{1}{4}$  inch diameter tubing. Connect the other collection chamber hole to the autoclavable tip with another length of tubing. The length of either piece of tubing can vary depending on how the device is used.

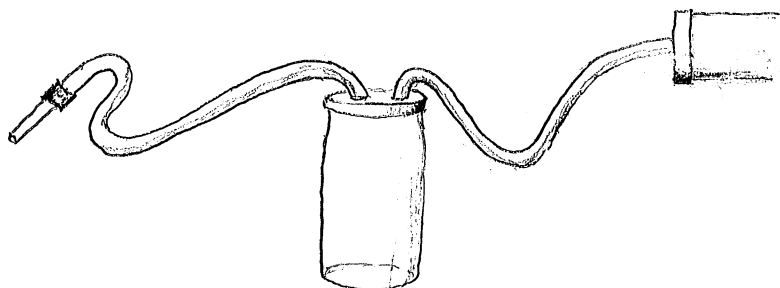

# Assembly of the connection rod, and installation of the piston.

Step 1: Make the connection rod

side view:

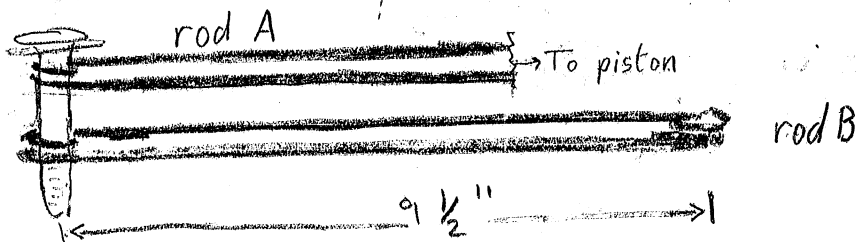

top view:

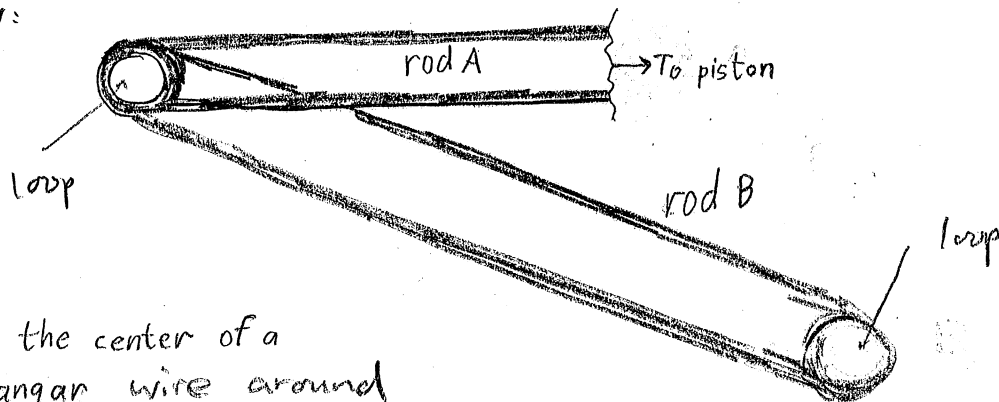

1) Wrap the center of a coathangan wire around a  $\frac{1}{4}$ " diameter bolt with  $1\frac{1}{2}$  revolutions, forming a loop; do the same at each of its ends, around another bolt, to make a rigid member with two loops, one at each end. The rod should be  $9\frac{1}{2}$  inches long.

2) Insert the piston into the vacuum chamber, after lubricating the chamber with powdered graphite.

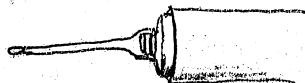

3) Bolt one end of rod B to the motor

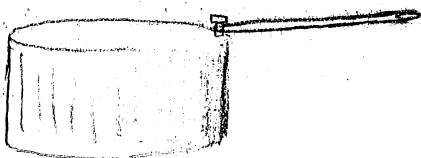

4) Bolt the other end of rod B to rod A through the slit in block D

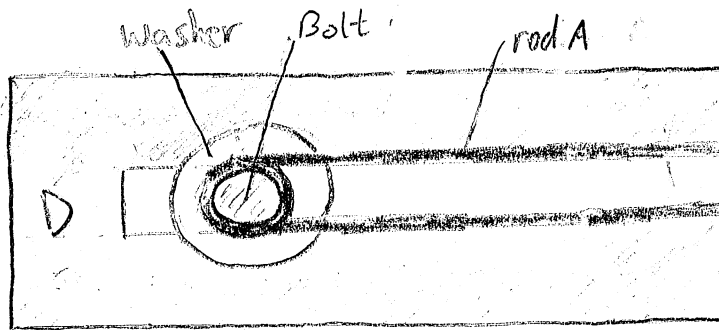
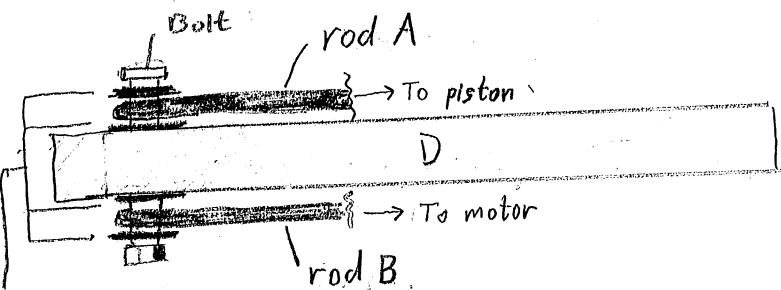

side view

top view

The final device should look like the diagram shown below:

