



Heating Device for μ PET/CT Machine

Client: Dr. Robert Jeraj
 Advistor: Dr. Brenda Ogle

Team Members: Victoria Vasys, Eric Bader, Eric Printz, Justin Schmidt

Abstract

During medical imaging, specifically μ PET/CT scans, small animals are anesthetized to ensure their lack of motion. Under anesthesia these animals, oftentimes mice, are subject to a significant decrease in body temperature that can lead to hypothermia or death. It has been proposed to design a heating device capable of providing a constant temperature near that of the subject's body temperature. After careful consideration of three potential design alternatives, a tube heater with the ability to provide hot air flow to a heat delivery system within the μ PET/CT scanning chamber has been selected as the best approach to the solution of this problem.

Problem Statement

Metabolism slows down during anesthesia. This can lead to hypothermia and eventual death. For prolonged μ PET/CT scans, where animals, often mice, are under anesthesia for an extended period of time, it is important to keep the animals at a steady temperature.

Therefore, we proposed to design an animal heating device that can:

- Be used to provide controllable and steady temperature during prolonged μ PET/CT scans.
- Adhere to imaging limitations - no metal or moving parts within the scanner's field of view.

Cost Analysis

- Clear Tube + End Caps - \$23.00
- Power Resistors - \$12.03
- Heater parts, tubing, valves - \$25.00
- Air pump - \$33.78
- TOTAL - \$93.81

Final Design

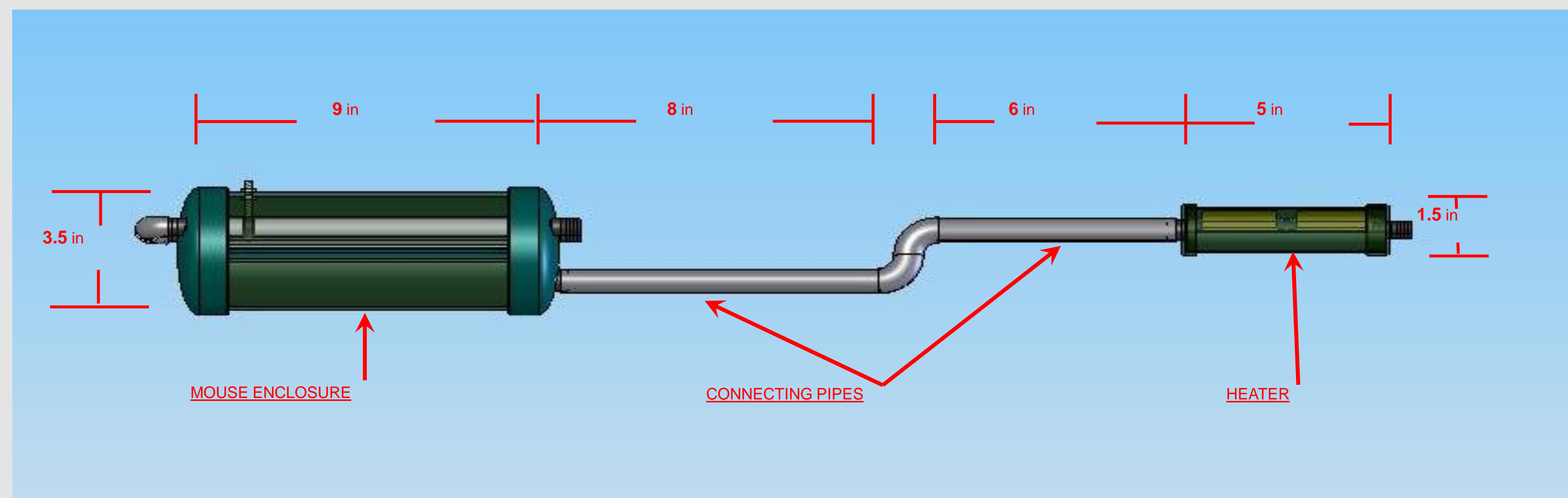

Figure 1: Complete design including heater, mouse enclosure, and PVC tubing

Client Requirements

- No metal parts in μ PET/CT field of view
- Provide controllable temperature
- Temperature constant near subjects body temperature
- No moving parts
- Device must fit inside μ PET/CT scanning chamber (10 cm. diameter)

Motivation

Our device will aid in solving the following problems relating to cancer research using mice as test subjects.

- Researchers invest a significant amount of time and money implanting and developing specific cancers in these mice. They also spend time devising treatment plans to see how the mice respond to them. Death of a test subject may prevent a researcher from making conclusions that could contribute to the field.
- Varying body temperatures throughout the course of a scan may decrease the scans accuracy, and a variance in temperature from scan to scan may cause inconsistencies in the images.

Design Components

Tube Heater

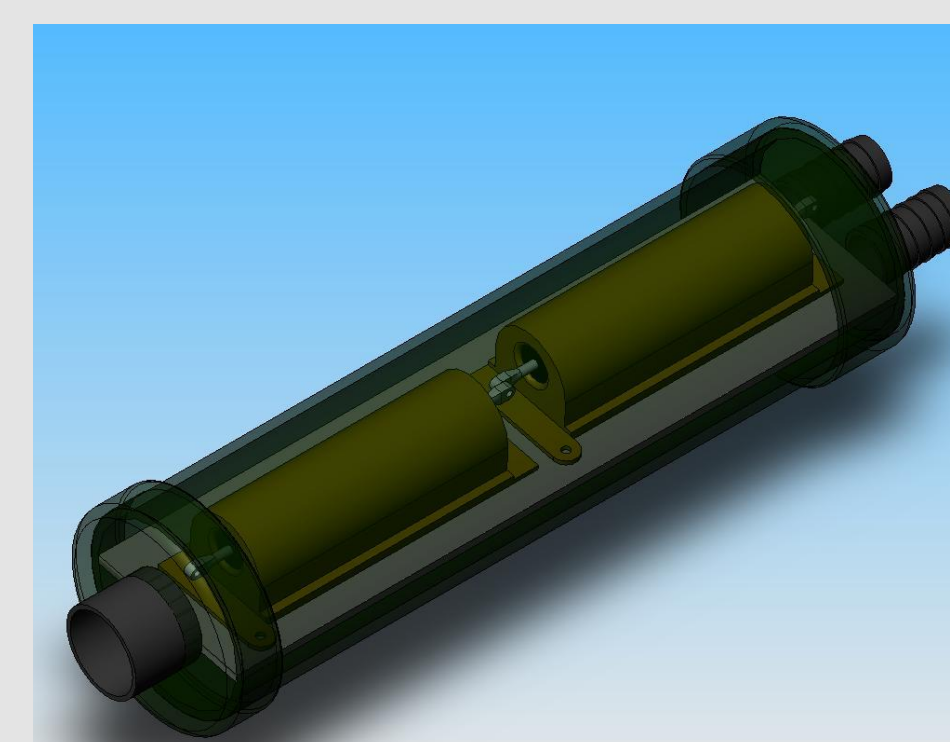

Figure 2: The tubular heater Solid Works drawing

- 2 power resistors heat air
- Air-tight enclosure for zero air flow loss
- Silicon inner insulation
- Outer polyethylene foam rubber insulation
- AC power source

Heat Transfer Calculations

$$(R_{conduction} + R_{convection}) * (T_{hot\ air} - T_{plate}) = m_{fumes} * c_p(fumes) * (T_{plate} - T_{fumes})$$

$$m_{fumes} = \rho * A * V = v * \rho$$

$$R_{conduction} = \frac{L}{k * A}$$

$$R_{convection} = \frac{1}{h * A}$$

$$T_{hot\ air} = 118.35^{\circ}F$$

Mouse Enclosure

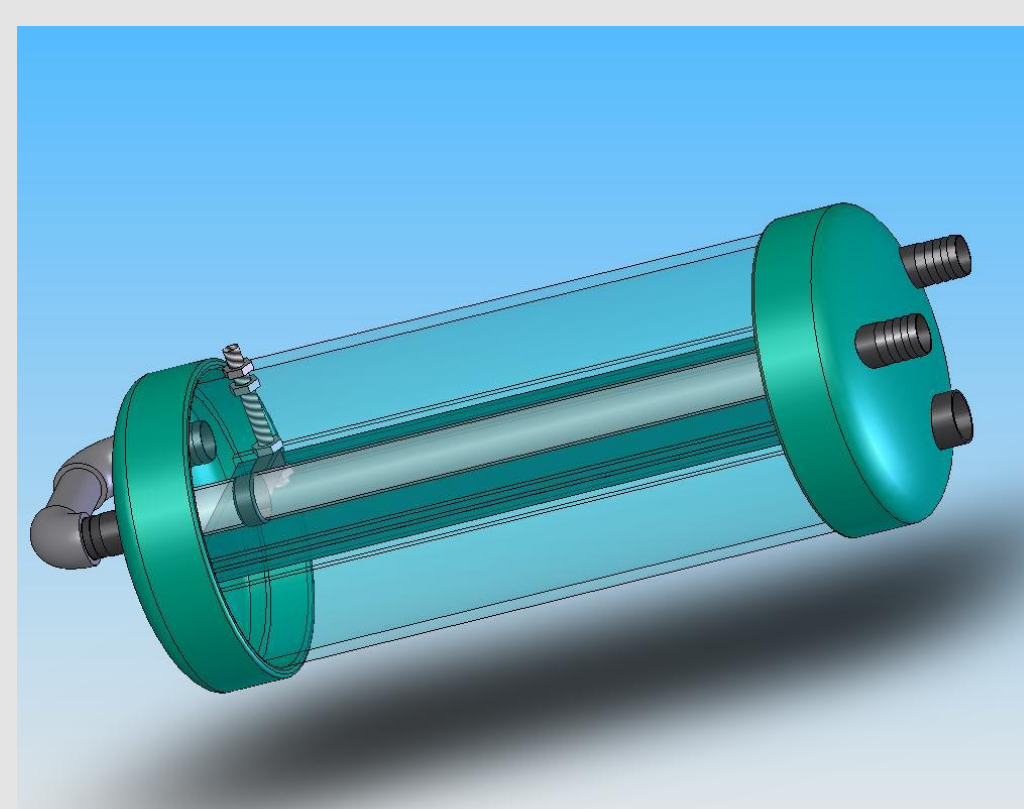

Figure 3: Mouse Enclosure Solid Works drawing.

- Separate chambers for anesthesia and heat
- Removable platform (.09" polyethylene)
- All parts are washable
- Input/Output on single side
- Insulation to maintain heat (.25" polyethylene foam rubber)
- polyethylene foam rubber)

Final Testing

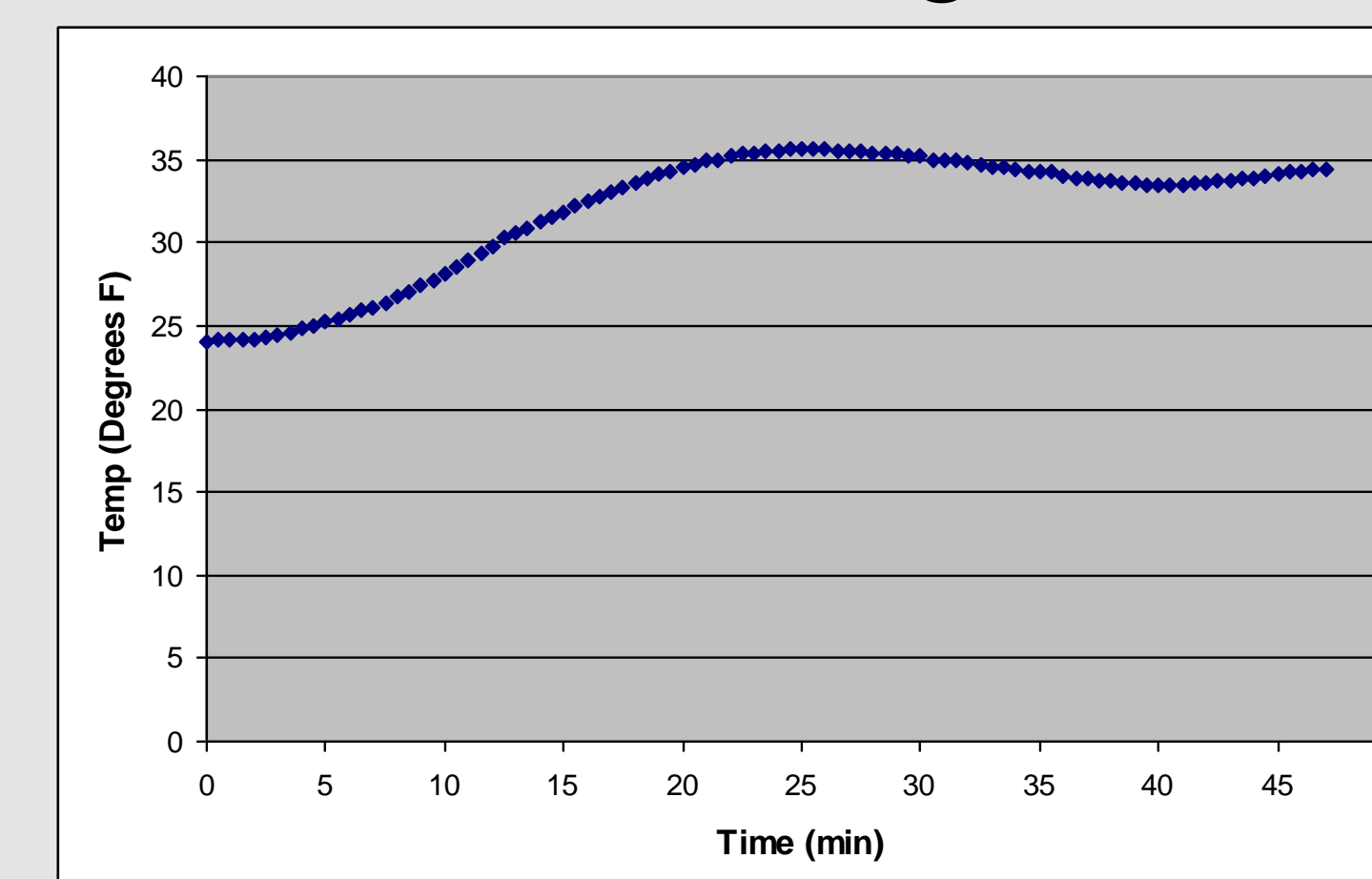

Figure 4: This is the platform temperature testing with the range of 33-36 C. We maintained the temperature at this range for half an hour turning the heater on and off when necessary.

Future Work

- Test with mouse and anesthesia circulation
- Design an electronic feedback mechanism for controlling temperature

Acknowledgements

- Amit Nimunkar
- Professor Ogle
- Mahesh Mahanthappa
- Paul Fraser
- L Burke Oneal

References

- Blodgett T, Meltzer C, Townsend D. "PET/CT: Form and function." *Radiology*. 242 No.2: 360-385, 2007
- Hrapkiewicz, Medina, and Holmes, *Clinical Laboratory Animal Medicine: An Introduction*, 2nd Edn., Iowa State University Press, 1998.
- Matsukawa T, Sessler D, Christensen R, Ozaki M, Schroeder M. "Heat flow and distribution during epidural anesthesia." *Anesthesiology*. 83: 961-967, 1995
- Plastics Materials Polyvinyl Chloride PVC. British Plastics Federation. [Online] http://www.bpf.co.uk/bpfindustry/plastics_materials_Polyvinyl_Chloride_PVC.cfm.
- Webster, J. G. 2004. *Bioinstrumentation*. Hoboken, NJ: John Wiley & Sons, Inc.