

12-Lead ECG Training Device

BME 400
University of Wisconsin – Madison
December 10, 2008

Team:

Cali Roen, *Team Leader*
Amy Weaver, *Communicator*
Laura Bagley, *BSAC*
Anthony Schuler, *BWIG*

Client:

Dr. Patricia Padjen
UW EMS Outreach Program Manager

Advisor:

Prof. Tom Yen
Dept. of Biomedical Engineering
University of Wisconsin – Madison

Table of Contents

Problem Statement.....	4
Background	4
<i>12 – Lead ECG</i>	<i>4</i>
<i>Existing Devices.....</i>	<i>5</i>
Product Design Specifications.....	6
Design Alternatives	7
<i>Feedback Circuit.....</i>	<i>7</i>
<i>LED Markers</i>	<i>8</i>
<i>Other Preliminary Designs Considered</i>	<i>9</i>
Final Design	9
Safety and Ethical Considerations	12
Future Work.....	12
References	14
Appendix A: Product Design Specifications.....	15
Appendix B: Decision Matrix	17
Appendix C: Budget	18

Abstract

Electrocardiograms (ECG) are used to measure the electrical activity of the heart and diagnose arrhythmias. Currently there is no training mannequin that teaches both 12-lead electrode placement and ECG signal interpretation in one device. The purpose of this project is to develop an adult mannequin that teaches placement of electrodes based on anatomical landmarks and provides the student with feedback about the accuracy of their placement. The same mannequin should also produce a variety of ECG output signals to teach diagnostics using 12 – lead ECG. Our chosen design uses light emitting diodes (LEDs) and fiber optics to mark the correct 12-lead ECG electrode placement. The device also includes a 15-lead ECG electrode placement mode. An ECG signal simulator will be incorporated next semester.

Problem Statement

Effective training methods are an important part of using an electrocardiogram (ECG) to accurately diagnose heart arrhythmias. Current methods for training emergency medical services (EMS) personnel to perform ECG recordings use either a mannequin that shows the correct placement of the electrodes or a human to practice on. The mannequins currently in use have visible electrode placement markers. This does not allow students to learn how to place the electrodes anatomically; they only need to match each electrode to a visible snap. The objective of this project is to develop an adult mannequin that can be used for 12 or 15 – lead ECG training and addresses the problems with the current training methods. Students should determine the placement of the electrodes on the chest of the mannequin using anatomical landmarks (i.e. the rib cage) and the mannequin should provide feedback about the accuracy of the placement. The mannequin should also produce a variety of ECG signals to be displayed when the electrodes are placed correctly.

Background*12 – Lead ECG*

An electrocardiogram (ECG) records the electrical activity of the heart and can be used to diagnose the type and location of arrhythmias of the heart (Yanowitz, 2006). The heart has nodes that produce electrical signals. The signal travels through the heart and surrounding tissue. The ECG electrodes measure this signal at select locations. An ECG lead is comprised of two electrodes. A lead is used to determine the electrical activity through a specific area of the heart. A 12 – lead or 15 – lead ECG can be used to more specifically locate the cause of a heart arrhythmia when compared to a standard 3- or 6 - lead ECG.

Ten electrodes are used for a 12 – lead ECG and fourteen electrodes used for a 15 – lead ECG (Yanowitz, 2006). There are four electrodes placed on each of the four limbs. These are the same four electrodes that would be used for a 3 – lead ECG. Two electrodes are placed at the center of the chest at the fourth intercostals on the right and left sternal borders; these electrodes are labeled V1 and V2 respectively. For a 12- lead ECG, electrodes V3 – V6 are placed on the left chest (figure 1). For a 15 – lead ECG, four additional electrodes are placed on the right chest, mirroring electrodes V3 – V6 on the left chest.

Figure 1: 12-lead ECG Electrode Placement

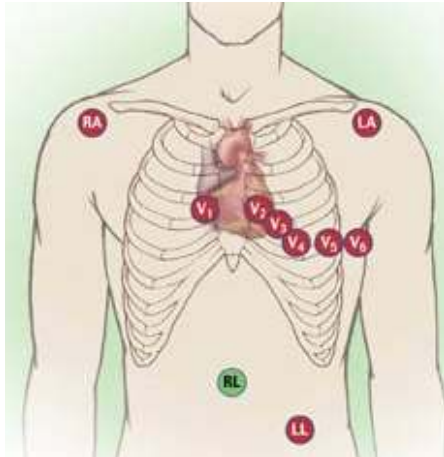

V1: Fourth intercostal space to the right of the sternum

V2: Fourth intercostal space to the Left of the sternum

V3: Directly between leads V2 and V4

V4: Fifth intercostal space at midclavicular line

V5: Level with V4 at left anterior axillary line

V6: Level with V5 at left midaxillary line (Directly under the midpoint of the armpit)

(American College of Cardiology, 2008)

Existing Devices

There are several existing devices on the market that are currently used to teach students to perform ECGs. The first is the Heart Sim 200 by Laerdal Medical. It is an ECG rhythm simulator that provides basic, modified, and pediatric rhythms. This device connects to other Laerdal mannequins. This is a rhythm simulator that does not teach electrode placement. The

second device is the Laerdal 12-Lead Task Trainer (figure 2). It is an adult male torso with connections for the four limb electrodes in addition to V1-V6 electrodes. The mannequin can be used with a monitor to display heart arrhythmias or for defibrillation. The disadvantage of this mannequin is that the electrodes are placed on the chest with clips, so the placement is visibly obvious and not taught. In addition to not effectively teaching placement, this mannequin is very expensive (\$8000+). There are also several other mannequins that offer 4 – lead ECG monitoring (Laerdal Medical, 2008).



Figure 2: Laerdal 12-Lead Task Trainer

Connects to ECG simulator and has connections for limb leads and V1-V6. Electrode sites are visible.

Product Design Specifications

The mannequin will be used to train EMS personnel to correctly place the electrodes used for 12-lead ECG monitoring. The device should provide students with feedback about the accuracy of the placement of the electrodes. If the electrodes are within one centimeter of the correct location, the placement should be considered correct. There should be no visual or textural cues to the placement of the electrodes other than the anatomical landmarks (the ribs and sternum). Once the electrodes have been placed and their accuracy has been confirmed, an ECG signal should be displayed on a monitor. The mannequin should be able to transmit a variety of heart arrhythmias.

This device should be able to withstand daily use by students and should be water resistant so the surface can be cleaned between uses. All wires should be hidden within the mannequin so that they are not damaged by cleaning and so they are not visible to the students. The signal generator and feedback system can run on standard AC power or a battery within the mannequin. The device will be incorporated into an existing adult CPR mannequin and should not increase the weight so much that it cannot be easily transported by an average adult. The device should be inexpensive and reproducible.

Design Alternatives

Most design projects focus on several different design alternatives from which one is selected in order to best solve the problem at hand. In the case of our project, we focused on several different components of one design. An ECG training mannequin requires several different components which is why our design required a different approach than most projects. To create a functioning ECG trainer, an ECG simulator, monitor, electrodes, and mannequin are all required. Since a simulator and monitor were provided, the focus of this semester centered on the mannequin and creating a feedback mechanism for correct electrode placement. Initially, the two proposed solutions were a feedback circuit and an LED marked placement design.

Feedback Circuit

The feedback circuit design utilizes an electrical connection between circuitry on the underside of the mannequin skin and the electrode. When the electrodes are correctly placed in locations V1 – V6, an electrical circuit is completed which lights up a separate display unit. The separate display would contain a light for each electrode. If the electrode is placed correctly, the light turns on. If the electrode is in the wrong location, its light would not turn on. This design

would require conducting an electrical signal through the mannequin's skin. Preliminary testing of the current mannequin skin showed it to be slightly conductive, but not conductive enough to complete the necessary circuit. For the feedback circuit design to work, the skin would need to be modified with metal tape or metal woven mesh to increase its conductivity. Additionally, the design would require all electrode locations to be electrically isolated to eliminate overlap that could potentially illuminate the wrong electrode location on the feedback display. This design requires a lot of circuitry (separate circuits for each of six electrodes), and modifying the design to have 15-lead ECG capability would be difficult.

LED Markers

The LED marked placement design also uses light as feedback for correct electrode placement. Unlike the feedback circuit design however, the lighting display is contained within the mannequin and hidden underneath the skin. An LED is used in combination with fiber optics to create rings of light underneath the mannequin skin in the V1 – V6 locations. Once the electrodes are placed by the trainees, a switch would be used to turn on the LEDs. The idea behind this design is that if all the electrodes are placed correctly, all of the light markers will be covered by an electrode. If light can be seen through the skin, the electrode(s) are in the wrong location and must be realigned. This design not only provides feedback for correct/incorrect placement, but also shows the trainee which direction the electrode must be moved for correct placement. It is important that the fiber optics remained hidden from sight and touch so as not to give away the correct electrode locations. 15-lead ECG capability could easily be added to this design by adding a second set of LED/fiber optics and a second switch to the circuit.

Other Preliminary Designs Considered

Several other design ideas were proposed during the course of the semester such as a stencil overlay or the use of radio frequency identification (RFID) technology to determine proper electrode placement. A stencil overlay would involve a plastic sheet that could be laid over a mannequin after the electrodes have been placed. Holes in the sheet would mark correct placement. If the electrodes are visible through the holes, the electrodes are placed correctly. This method, however, would not be as accurate as the two discussed above because of placement variability every time the sheet was applied and removed. RFID technology was ruled out because it is designed to recognize tags over greater distances and would not supply the 1 cm accuracy needed for this device.

Final Design

Prototype

After considering the preliminary designs (see decision matrix, appendix b), we decided to pursue the LED/fiber optic marker design. One fiber optic cable per electrode was used to mark each electrode placement site. Six electrode placement areas (V1-V6) are marked on the left side of the chest for a 12-lead ECG and an additional four areas are marked for the 15-lead ECG. The fiber optic cables are threaded into the chest plate, just inferior to the mannequin's skin. These thin cables cannot be felt by the student. The other ends of the cables are fixed to an LED light source. The light source is connected to a switch which is external to the mannequin.

Circuitry

The circuit (figure 3) is composed of two on/off switches and two LEDs. One switch controls the 12-lead mode and the other controls the 15-lead mode. The 12-lead mode requires one LED to turn on. This LED lights the optical fibers that mark V1 – V6. The 15-lead mode

requires both LEDs to turn on. This is because a 15-lead ECG uses the same V1 – V6 electrodes plus four more electrodes applied to the opposite side of the chest. A quad 2-input OR logic gate (figure 4) was used in the circuit to allow one of the LEDs to be controlled by both switches (i.e. one switch turns on one LED, the second switch turns on both LEDs). The OR truth table is shown in table 1. The circuit is powered by a 5 V AC wall adapter.

Figure 4: OR gate diagram

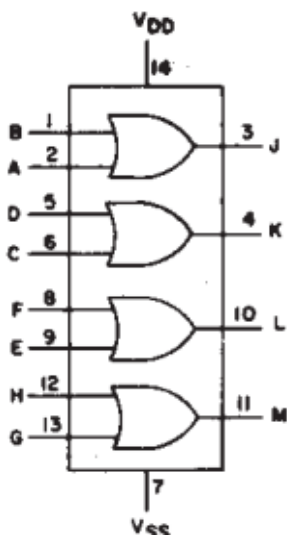

The chip has four 2-input OR logic gates. Only two of the gates were used: one for the 12-lead mode and one for the 15-lead mode.

Figure 5: Circuit Diagram

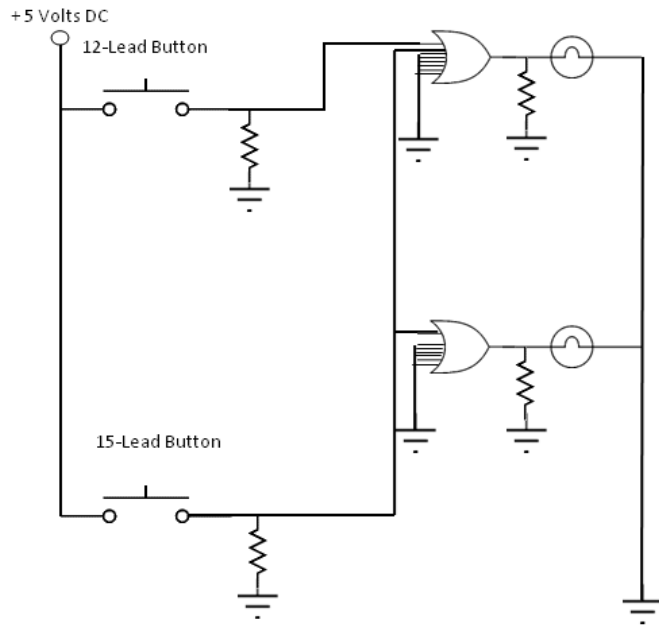

The circuit is powered with 5 V and uses 2 OR logic gates, 2 switches and 2 LEDs.

Table 1: OR Truth Table

Input A	Input B	Output
1	0	1
0	1	1
1	1	1
0	0	0

Device in Use

The student would place the electrodes on the mannequin in either a 12-lead or 15-lead configuration. Once the electrodes are placed, the button corresponding to the appropriate configuration would be pushed causing the correct electrode sites to light up. If the light is visible around the electrode, it is in the incorrect place and the student should turn the lights off and try again.

Budget

The materials used this semester mostly centered on those required for the circuit. Two OR gates, two switches, 10 feet of fiber optic cable and two LED light sources were purchased. The mannequin was donated to us by our client. The materials altogether cost approximately \$42 (see budget, appendix C).

Safety and Ethical Considerations

The biggest safety concern with this design is the current amperage in the circuit. A current of 100 mA is enough to push the human heart into fibrillation (Lunt, 1999). The largest current we measured in our circuit was 50 mA. This is well below 100 mA. Also, the circuitry is hidden inside the mannequin and should not come into direct contact with the user. Since this device will be used to train medical personnel how to perform a 12-lead ECG, electrode sites must be marked extremely accurately to ensure users are trained correctly.

Future Work

Several improvements to this prototype will be made next semester. The first goal is to make each electrode marker bigger by clustering fiber optics. Additionally, we need to purchase LEDs with a larger surface area so several optical fibers can be connected to one LED. We will

also explore the option of directly marking each electrode site with an LED and eliminating the use of fiber optics. This option was not initially considered because we thought LEDs would create bumps on the surface of the mannequin that users would be able to feel when placing electrodes. We now have found LEDs with flat surfaces (figure 5) that could be mounted in the chest plate of the mannequin.

Figure 5: LED with flat top



This LED from Digikey (part #365-1346-2-ND) could be mounted directly in the mannequin's chest plate and would not be felt when feeling for ECG electrode placement.

The second goal is to incorporate an ECG signal generator into the mannequin. The ECG signal generator and monitor have been provided to us by our client. We will need to modify the mannequin skin to conduct electricity so the signal from the generator can be passed through the skin, to the ECG electrodes and be displayed on the monitor. This will most likely be accomplished by applying metal tape to the underside of the mannequin skin.

Other goals include encasing the circuitry to make it more durable and water resistant, miniaturizing the circuit and conducting usability testing.

References

Laerdal Medical. 20 Sept 2008. <www.laerdal.com>

Lunt, B. 1999. "Safety With Electricity." *The Technology Interface*. 3(3).

"ECG Stress Testing." *CardioSmart*. 2008. American College of Cardiology. 20 Sept 2008.

<www.cardiosmart.org>

Yanowitz, F G. "The Standard 12-Lead ECG." *ECG Learning Center*. 2006. University of

Utah School of Medicine. 24 Sept 2008. <<http://library.med.utah.edu/kw/ecg/index.html>>

Appendix A: Product Design Specifications

12 Lead ECG Trainer Laura Bagley, Cali Roen, Anthony Schuler, Amy Weaver October 14, 2008

Function:

An adult mannequin will be developed to be used for 12 and 15-lead ECG training. The mannequin should produce a variety of ECG signals. Students should place ECG electrodes on the chest using anatomical landmarks and the device should provide feedback about correct and incorrect placement.

Client Requirements:

- Placement of electrode leads should be found using anatomical landmarks
- Individual visual indicators for correct/incorrect placement of each electrode lead
- ECG signal output when all electrodes are placed correctly
- Endure daily use by students
- Battery operated
- Withstand cleaning using standard cleaning procedures

Design Requirements

1. Physical and Operational Characteristics

- Performance requirements:* The placement of the electrode leads should be found using anatomical landmarks including the clavicle, ribs, and sternum. Feedback should be given about the accuracy of the placement. When the electrodes are correctly placed, a variety of heart arrhythmias should be displayed. The devices should withstand daily use by students and should be able to be cleaned using standard cleaning procedures.
- Safety:* All circuitry should be insulated and hidden from the user to prevent shock. Wiring should be protected so that cleaning does not short-circuit the wiring.
- Accuracy and Reliability:* Electrodes must be placed within a 1 cm radius of the correct location to register as “correct placement.” The device should not disrupt or alter the transmission of the ECG signal.
- Life in Service:* The device should last five years of weekly use with cleaning after each use.
- Operating Environment:* The device should be water resistant to withstand cleaning. The device will be used in an indoor classroom environment by numerous students.

- f. *Size*: The device should fit a standard adult CPR mannequin.
- g. *Weight*: The device should be easily lifted by an average adult.
- h. *Materials*: Ideally a material that mimics the electrical conductance properties of skin should be used. The material should be dark enough to hide underlying circuitry but also be able to transmit light from LED placement markers.

2. Production Characteristics

- a. *Quantity*: One unit to be used by Dane County EMS
- b. *Target Production Cost*: Cost must be affordable for the Dane County EMS.

3. Miscellaneous

- a. *Customer*: The client wants a visual indicator for correct/incorrect placement of *each* electrode lead and an ECG printout when all leads are positioned correctly.
- b. *Competition*
 - i. *12 Lead ECG Placement Trainer*, Armstrong Medical
 - 1. Correct placement for electrodes are visibly marked
 - 2. expensive (\$865)
 - ii. *12 Lead Task Trainer*, Laerdal
 - 1. Correct placement for electrodes are visibly marked
 - 2. expensive (\$8299)

Appendix B: Decision Matrix

	Feedback Circuit	LED Markers
Feasibility (30)	13	24
Client Preference (25)	10	21
Ease of Use (20)	15	17
Durability (15)	7	9
Cost (10)	8	8
Total (100)	53	79

Appendix C: Budget

Material	Description	Company	Part Number	Quantity	Cost per Unit (\$)	Total Cost (\$)
Switch	SWITCH PB SPST ALT ACT BLACK	Digikey	504PB-ND	2	1.54	3.08
Switch	SWITCH PB SPST ON-OFF BLACK	Digikey	501PB-ND	2	1.36	2.72
Switch	SWITCH PB SPST N/C MOM SOLDER	Digikey	503PB-ND	2	1.64	3.28
LED light source	Red	Digikey	492-1139-ND	1	9.90	9.90
LED light source	White	Digikey	365-1346-1-ND	2	4.74	9.42
OR gates	8-INPUT NOR/OR GATE	Jameco	CD4078	3	0.45	1.35
Fiber Optic Cable	3mm Plastic Unjacketed Fiber	Fiber Optic Products	-	10 feet	1.17 / ft	11.70
TOTAL COST						41.45