

Computer Control of Liquid Delivery for use with Microscopy

December 12, 2008

Joseph Decker, Justin Gearing, Daniel Miller, Stephen Welch

Client: Ian Bird, PhD; Bikash Pattnaik, PhD

Advisor: Professor Paul Thompson

Table of Contents

Abstract.....	3
Current Design.....	4
Problem Statement.....	5
Design Criteria.....	6
Final Design.....	7
Testing.....	17
Budget.....	20
Future Work.....	21
References.....	22

Abstract

Our clients, Dr. Pattnaik and Dr. Bird, are currently researching the dynamics of molecular transport across a plasma membrane. Currently, these experiments are done by hand and are time consuming and inaccurate. The clients would like an automated liquid delivery system make their experiments more efficient. This system must be easy to use, portable, and compatible with existing equipment.

The final design uses LabVIEW to control a series of valves which release reagents upon activation. The user can specify on and off times for each valve or can manually control each valve if desired. The valves are mounted to a valve panel which can interface with the existing reagent set up. The electronic components of the system (LabJack U12 interface, NISC-2602 power relay, and CB 25 circuit board) are stored in a case in order to give the system portability and allow the user to separate the electronic components from the valves. The valve panel can also be placed in the case for transport or storage.

The accuracy of our design was tested by measuring the difference between the programmed response time and the actual response time of our prototype. The accuracy was found to be within an average of 1.042%. The design was tested to ensure a constant flow rate; it was found to reproduce the same rate with successive trials.

The client found that the controller worked well with his experiments. The system had no back flow when tested with an 8-1 tubing junction. The system was also able to run one of the client's experiments with the expected result, leading to the conclusion that it can be successfully integrated for future experiments.

Future work for the project includes issue raised by the client: decreasing the case's footprint, integrated the LabVIEW program with the client's data collection software, and increasing the accuracy of the interface. Additional work that can be done is integration of a flow rate control system, increasing the longevity of the valves, and improving the clamping mechanism of the valve panel.

Current Design

Our clients, Dr. Bikash Pattnaik and Dr. Ian Bird, are currently performing microscopy experiments studying the transfusion of calcium and other chemicals across a plasma membrane. Various reagents are placed in syringes mounted to a panel, connected to a ring stand (Figure 1). Each syringe has a manual valve that allows the reagents to flow out. One syringe contains a buffer solution whose valve is always open. The reagents then travel by 3/32" (2.39 mm) high performance liquid chromatography (HPLC) tubing to an eight-to-one HPLC tubing junction. This eight-to-one junction sends the reagents to a three-way solenoid valve. This valve has an independent power supply. The buffer solution connects directly to the three-way solenoid valve, skipping the eight-to-one juncture point. The outlet of the three-way solenoid valve sends the liquid to the microscope stage for experimentation.

This current system is susceptible to timing inaccuracies, due to manually turning each valve. It is also difficult to measure open valve times. This prevents our clients from precisely analyzing

their experimental data. Using the manual valve system also requires the lab staff to be present through the entire experiment, sometimes lasting two hours.

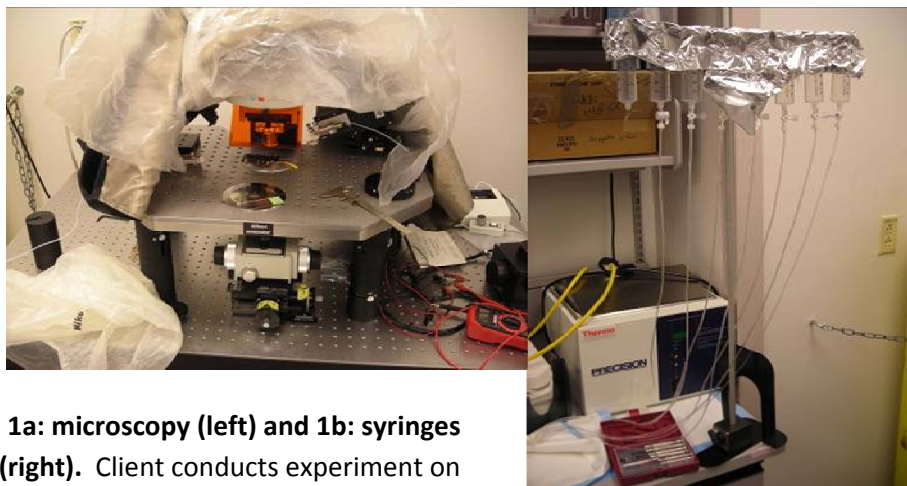

Figure 1a: microscopy (left) and 1b: syringes (right). Client conducts experiment on microscope stage. Currently releases each solution manually via syringes.

Problem Statement

The clients' current setup for doing experiments is both time consuming and error prone due to the manual nature of the design. They would like us to construct a device that will be able to deliver liquid reagents to a microscope stage for set amounts of time without constant human intervention. This device should utilize the overall delivery method as the current setup; that is, the reagents should be placed in syringes and then allowed to flow onto the microscope stage, with the difference being the automated control of the valves. The liquid delivery controller must not interfere with the experiment in any way; it cannot produce an electric field, kill the cells, or be too bulky to be used in a limited space. The clients would also like the controller to be portable, as it is anticipated that multiple labs will use the device.

Design Criteria

Dr. Bird and Dr. Pattnaik would like a fully automated reagent delivery system. They want to program well defined on and off times for each valve prior to an experiment. Our goal was to create a user-friendly program that was easy for users of all computer skill levels to use. Another goal was making the program convenient and efficient for the user. This means that the program can perform multiple tasks by turning valves on or off, and saving information about on and off times. This will save the client time by not having to reprogram the valves each time an experiment is duplicated. The saved data will also provide our clients the opportunity to use in their analysis and experimental reports.

The design must also be chemically friendly. No foreign contaminants can enter the experiment in any way. All components of the design coming in contact with the solutions cannot react with the reagents or corrode. Salty solutions will be used, which can corrode components over time, so careful consideration must be taken when selecting materials.

All components selected for the design must be reliable, as any malfunction would cost our clients time and money. All components must be standardized so if any do break, our clients can quickly find, order, and install replacements. The fabrication and assembly is simple enough that reinstallations can be accomplished by using basic tools. Reinstallation of any component should not cause damage to any other components.

Lastly, this device may be used by multiple labs in the future; therefore, our design must be transportable. Our goal is for the device to be transported quickly and safely. We want assembly and disassembly to be efficient for the user. Durability during transport is essential; components must be securely fastened as to not be harmed during transportation.

Final Design

In the final design of our case, we were able to meet all of the structural criteria of our clients.

The valve panel consists of a 1/8 x 4 x 12 inches (0.32 x 10.16 x 20.32 cm) aluminum plate.

Aluminum was used in order to keep the weight to a minimum and still maintain a high level of structural integrity. The panel's height and width allows ample room for all valves and also accounts for the width of the syringes above them. The plate attaches to the ring stand through a simple clamp which is easily tightened by hand using a wing-type fastener.

The 8 valves being used are mounted by two screws directly on the front face of our aluminum plate. The valves are 12V solenoid valves, seven of which are normally closed (NC), while the left-most valve is normally open (NO) for the buffer solution which will generally have longer running times. Since these valves have a resistance of 126.7 k Ω ,

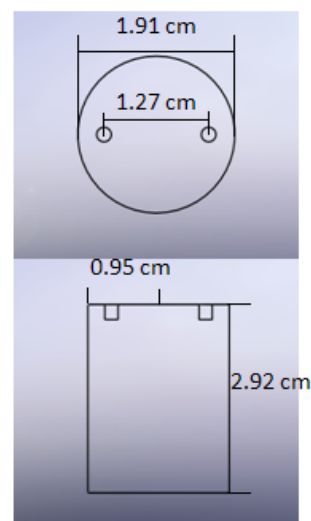

Figure 2: Solenoid Valve Dimension. 12V solenoid valves used for reagent control. A power relay was needed in order to supply the 12V necessary for the valves.

extended operational use will eventually overheat the valves, causing breakdown. After testing the valves, we know they have an on voltage of 7.6V (58 mA), with an off voltage 1.6V (13 mA). These numbers are important to note, as they deviated from the 12V (1.15W) as indicated by the product specifications [1].

The clients desired a transportable design so a case was necessary to house all of the electrical components running the valves. The plastic case we chose has dimensions of 15 x 21 x 7 inches (38 x 53.34 x 17.80 cm). Plastic is the best material for a case as it allows for the greatest flexibility for uses and adjustments that were made during the fabrication of the case. The case houses all of our electrical components so they can be easily transported between clients without much trouble. The program interface and power relay all easily fit within the space allotted by the case. The case also protects the electrical equipment from exposure to the liquids being used in and around the experiment being conducted.

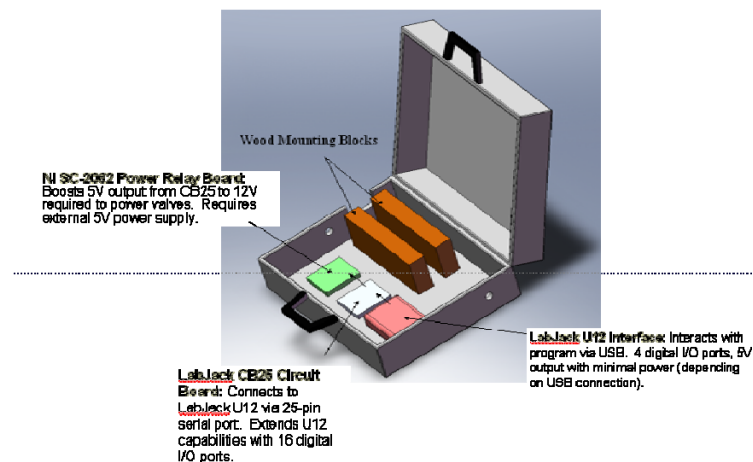

Figure 3: Case and Electrical Components. Case houses all of the electrical components as well as the valve panel for easy and efficient transportation.

In order to satisfy the clients' desire for a fully transportable design, the valve panel can be mounted inside the case. The dimensions of the case we specifically chosen to ensure the entire valve panel and the mounting clamp attached would fit. The valve panel mounts on two wooden

blocks with Velcro, where it remains until the client reaches his or her destination and re-assembles the valve panel onto an existing ring stand. This will also help prevent damage to the valves from transporting them without a case.

LabVIEW

The clients requested the graphical programming language LabVIEW be used to control the valve system. This allows for easy integration into other programs. LabVIEW is a good choice overall, since it possesses a user-friendly front panel, it is easy to utilize, and it is effective for real-time output and feedback.

The front panel of the program has many components. Buttons and labels were designed to minimize any confusion while operating the program. However, some instruction is still necessary to fully understand its function and capabilities. Additionally, some flaws still remain in the system, and knowledge of these bugs will help to avoid program crashes. The following lays out the different components of the program, how to operate them, and any remaining errors that have yet to be debugged:

Main Array

The main array has seven indices, each for the operation of a single valve. Within each index, the user can define when the indicated valve will turn on and for how long. Each index also contains a button that allows manual control of the valve during experiment run-time (Figure 4). Originally, the array was intended to be extendible; that is, the user could easily drag the array bottom down, creating more indices and allowing more timings to be programmed. However, since each array index must be handled individually (in parallel) for proper valve operation, this feature is not available. Therefore, it is important to note that tampering with the array's length in any way is strongly discouraged, and would likely lead to a program crash.

Figure 4: Main Array. Allows user to program valve timings for experiment run-time. Buttons are for manual valve control if desired.

Another important bug to consider is the fact that while the valve number can be changed for each array index, changing the valve numbers may create issues with the valves themselves. The causes behind this are not completely known, but on some occasions, changing the valve number selector caused the valve to toggle on and off rapidly like a flickering light. This is possibly due to having the same valve number in multiple parts of the array. If one index tells a valve to turn

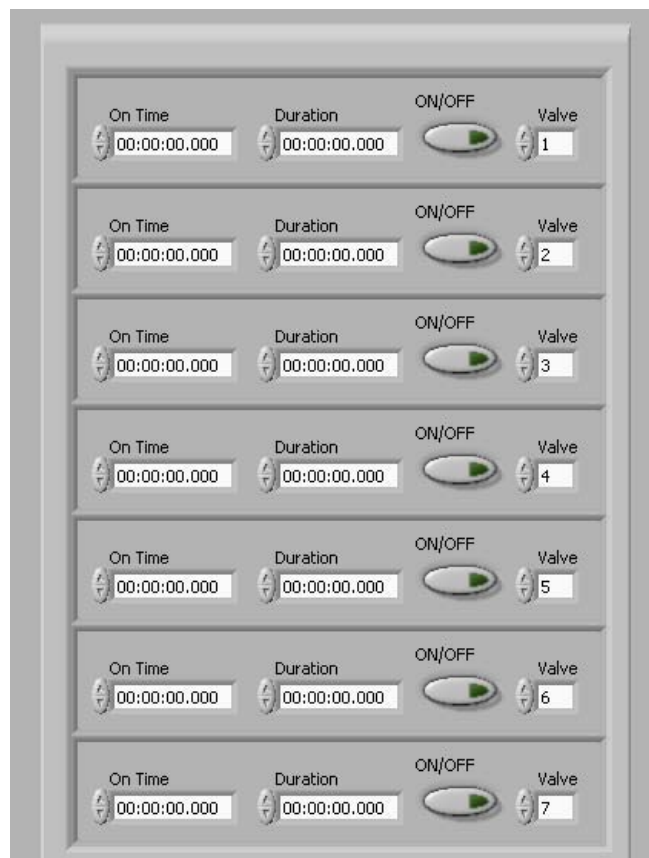

on, while another index tells the same valve it should be off, then this could cause the rapid alternation between on and off in the valve. This leads to another important consideration; the program has no fail-safe in case more than one valve is turned on at the same time. It is possible to have multiple valves on simultaneously (the buffer valve is actually on whenever another valve is on); however, turning too many valves on will drain the power available from the interface, which could lead to unknown valve behavior.

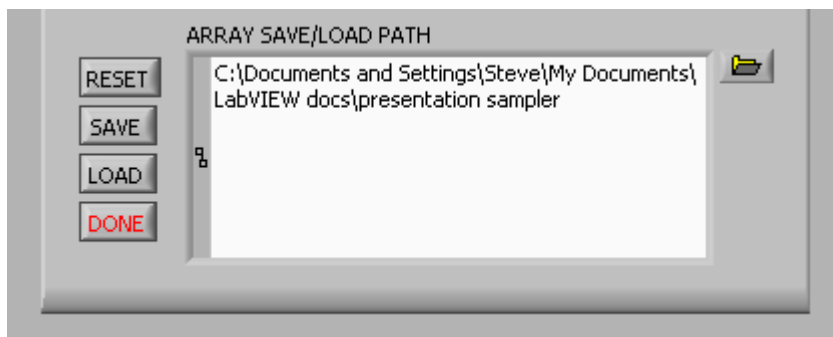

Figure 5: Array Controls. Buttons to reset, save, and load the array from/to adjacent file path.

Below the array lie several more buttons and a file path (Figure 5). The buttons allow the user to reset the array, save the array, or load an array. Pressing the RESET button will set all on times and off times to zero, all buttons to off, and the valves in ascending order from top to bottom (one, two, three, etc.). Pressing the SAVE button will save all the timings, buttons, and valve numbers to the specified file path. Setting this file path can be done by pressing the open folder button adjacent to the file path field, then entering the desired location and name for the path. Files can be saved in .txt format or with no format at all. To reload a previously saved file path, press the LOAD button; this will load the array from the same file path used for the save button. If the file path used is not a saved array (making it an invalid file), the program will crash. If either the SAVE or LOAD buttons are pushed, the file path must contain a non-empty path. If the file path is blank, the program will crash. Additionally, if using the load file path button after

starting the program, hitting cancel in the open file window will crash the program. Barring any previously mentioned errors, all three of these buttons will work before the experiment, during the experiment, or after the experiment, until the DONE button is pressed to end the program.

Experiment Buttons

To the right of the main array lies several buttons used to initiate, proceed with, and stop the experiment (Figure 6). Since the buffer valve is normally open, it must be closed by the program before the user can load the buffer solution. In order to do this, press the LOAD BUFFER button (it should light up). This will close the buffer valve, allowing the solution to be loaded.

Figure 6: Experiment Controls.
Initiates and ends experiment. Time log saves to adjacent file path. Also indicates experiment time during trial.

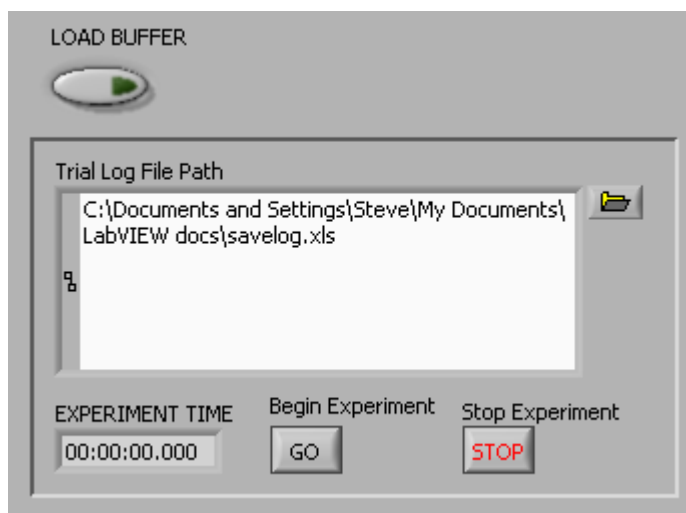

When all the desired timings are entered in the main array (optional), the Begin Experiment (GO) button will initiate the experiment, starting the experiment time and allowing the user to turn the valves on or off manually if desired. Before this button is pushed there must be a file path entered in the Trial Log File Path field. If this path is blank, the program will crash, similar to the Array Save/Load Path previously mentioned. Also similar, hitting the cancel button in the Open File window will crash the program. A suggestion for both file paths is, while in edit mode, select a “junk” file path that does not matter, then right-click the path window on the front

panel, scroll down to “Data Operations,” and select “Make Current Value Default.” Save the program (File > Save). This way, if the user forgets to enter a file path, it will be saved to the default file path and the program will not crash.

The Stop Experiment button ceases the experiment. At this point, all valves will turn off, including the buffer valve, so any remaining buffer solution will continue to drain. The array can still be saved at this point. To end the program, the DONE button below the main array is executed.

Manual Buffer Mode

During the experiment, the buffer is programmed to automatically cease dispensing whenever another valve is turned on; this prevents mixing any solutions with the buffer solution. If the user would like to override this automation, a manual buffer mode is available (Figure 7).

Highlighting this button will turn this mode on. When the buffer release button is lit, the buffer valve will open, releasing buffer regardless of any other valve activity.

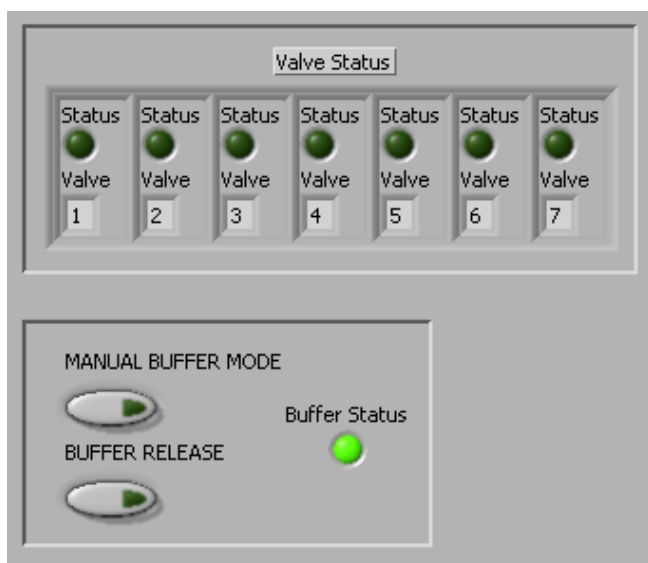

Figure 7: Manual Buffer Controls. Sets and controls manual buffer mode. Also indicates buffer and valve status.

Hardware

LabJack U12 Interface

The LabJack U12 was used to interface the program with the valves themselves. This device outputs the signals from the program to its various digital I/O ports (Figure 8). LabJack plugs directly into USB, making it very convenient for a lab environment, since almost all laptops would be compatible. The U12 has four digital I/O ports, driving up to 5V at 25 mA each with a delay of up to 20 ms [2].

Figure 8: LabJack U12 interface. Sends low voltage signals to turn on/off each valve. Low voltage digital I/O signals from device must first be boosted to meet valve requirements [2].



CB25 Circuit Board

As previously mentioned, eight valves were required, and the U12 only has 4 digital I/O ports. The CB25 Circuit Board from LabJack extends the U12's 4 digital I/O ports with an additional 16 I/O ports (Figure 9). These ports have the same voltage and current output available as the U12 (5V, 25mA) with the same time delay (20 ms) [3]. For this design, CB25 ports D0 – D7 were used, with D0 corresponding to the NO buffer valve, D1 corresponding to valve 1, D2 corresponding to valve 2, and so on. It is important to note that here is where the limitation lies with the number of valves available at any given time. The power relay (see next section) requires a minimum of 3.85V at 0.93 mA for each input, and the CB25/U12 derive all of their

power from the USB connection, so operating eight valves at a single time requires 7.44 mA.

Power availability from USB can vary depending on the computer, but draining too much power from the CB25/U12 will cause the program to crash.

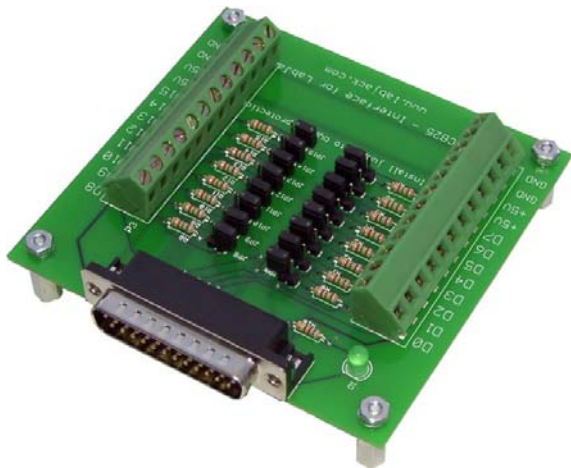

Figure 9: CB25 Circuit Board. Extends U12's digital I/O ports by additional 16. Ports D0-D7 were connected to NI SC-2062 [3].

NI SC-2062 Power Relay Board

Since the voltage output from the CB25/U12 is much too low to operate the 12VDC solenoid valves, a power relay was required to switch the low voltage outputs from the LabJack to the high voltage necessary for operation. The NI SC-2062 Power Relay Board (Figure 10) was designed for such a task. The device has eight relays in parallel, each with three ports: normally open (NO), normally closed (NC), and common [4]. Each NO port was connected directly to one node of its corresponding valve, with the other node connected to the ground port of an AC/DC adaptor wall plug, supplying 12VDC and up to 1500 mA. Each NC port was left open-circuited, and each common port was wired to the AC/DC adaptor. When activated, the relay switches the NC port to the NO port, completing the circuit and running 12V to the valve,

switching it on. This relay has a maximum activation delay of 6 ms, and a maximum deactivation delay of 3 ms.

Figure 10: NI SC-2062 Power Relay Board.
Boosts low voltage signals from U12/CB25 to 12VDC required for valve operation [4].

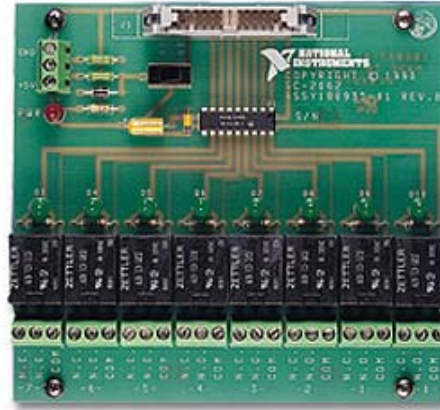

Normally, a 25-pin ribbon cable connects the power relay board directly to a LabVIEW interface. However, the LabJack does not have a 25-pin ribbon cable plug-in, only screw terminals for digital I/O. To connect the ribbon cable to ports D0 – D7 on the CB25 board, the cable was spliced, using the pin connections according to product specifications [4].

Powering the relay board requires 5VDC with up to 490 mA, normally supplied by the interface. However, since power supply from the LabJack is limited by the USB connection, an external 4.5V AC/DC adaptor wall plug provides the necessary power. This means operation of the case requires two wall outlets, one for the 12V adaptor, the other for the 4.5V adaptor.

Testing

Flow Rate Test

The valve panel was tested to ensure that it could reproduce a flow rate over several trials. The valve panel was set up as seen in Figure 11, and 50 milliliters of distilled water was poured into one of the syringes.

The valve controlling the full syringe was activated using LabVIEW, and remained open until 10 milliliters of water had drained out. This process was repeated until the syringe was empty, and then again for another 50 milliliters of water for a total of 10 trials. For each trial, a flow rate was calculated using the initial and final volume of liquid and the time the valve was open as recorded by the LabVIEW interface's save feature; this data is compiled in Table A1 (Appendix A). An average flow rate was then calculated to be 0.378 mL/s with a standard deviation of 0.042 mL/s. Two data points were found to be more than one standard deviation from the average. These outliers both occur during the second run of 50 milliliters, and can be attributed to a slight change in the setup (the tubing was given a different orientation in order to prevent damage to the electronics in our design). It is therefore concluded that the valve panel does not significantly affect the flow rate from the reagent reservoirs.



Figure 11: Flow rate test set up. Set up is similar to client's working conditions

Accuracy Test

The LabVIEW program and subsequent components were tested for the accuracy between the set valve-on duration and the actual valve-on duration. This was accomplished by reading the voltage through the valves using an oscilloscope. The valve was set for a one second on time, and then the program was run. The corresponding oscilloscope reading can be seen in Figure 12; this

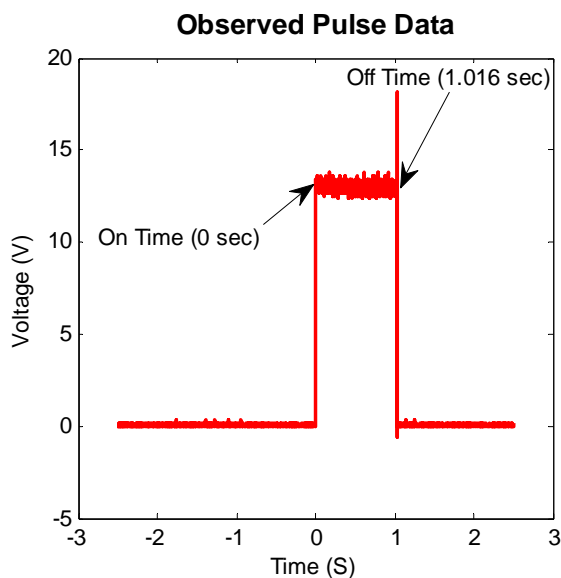

Figure 12: Observed Pulse Data. Oscilloscope reading used to obtain actual duration of one second valve pulse.

reading was analyzed using MATLAB to determine the time between the voltage spike and drop off. Data from 13 trials was collected, and the average inaccuracy for these trials was found (Table A2, Appendix A). When the LabVIEW program was set to run for one second, the average actual valve on time was 1.016 seconds, or 16 milliseconds longer than desired. The average error was 1.042%.

Lab Test

The prototype was tested out under experimental conditions. The prototype was set up as seen in Figure 13:

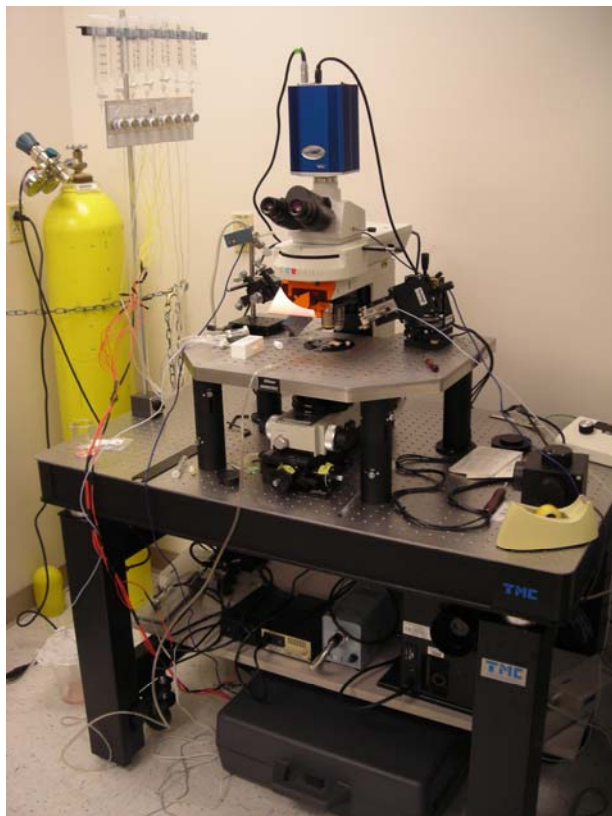

Figure 13: Liquid controller set up with the client's microscope. LabVIEW program is on a desktop computer to the right (not shown).

The valve panel was attached to the ring stand beneath the reagent reservoirs as in the previous tests. However, the client's lab is using a desktop computer, so the case was placed on the floor beneath the microscope and the LabJack hooked into the computer off to the side (rather than on top of the case as in Figure 11). The tubing from each reservoir runs to an eight-to-one junction,

and from there flows up to the microscope stage. A vacuum drains the stage, which is located near the case on the floor.

After instructing the client how to use the program, the experimental setup was tested to ensure there would be no backflow in the system. Distilled water was loaded into the buffer reservoir, and colored water into another reservoir. The system was then turned on for twenty seconds and then turned off, and the tubing examined for backflow (a mixing of the red and clear fluids).

After five trials, no back flow was observed in the system.

Once the client was assured that the reagents would not mix, an actual experiment was run. The experiment used the same setup as the flow rate test, except actual buffer solution was used instead of distilled water and an acetylcholine solution was used instead of the red water. After running through a full experiment, it was determined that the liquid controller did not alter the experiment in anyway; that is, the experiment produced results that were similar to what was expected, with any error coming from improper experimental technique and not from the liquid controller.

Overall, the client was satisfied with the product. He expressed some needs for the future, specifically making the system integrate with his experimental program and making the case more compact

Budget

We did not have formal budget restraints. Cost efficiency was still considered in the purchase

of components. The client requested that we use a specific valve in our design. Before we made purchases, the client approved our proposed budget. The cost totaled \$898.61. For budget and product details see Appendix B.

Future Work

The biggest concern currently with the controller is the accuracy. Our client asked for one millisecond accuracy, and our product has produced an average of 16 millisecond accuracy. While this was not an issue in the test described above, it will be a factor in the future.

We also need to address the concerns raised by the client. The case is currently too large to fit in most labs (including some that may have use for the controller in the future), so it will need to be consolidated. The LabVIEW program also needs to be integrated with the data collection software the client uses, thereby enhancing the efficacy and accuracy of the product.

Other improvements that could be made to the controller include making modifications for longer duration use, changing the clamping mechanism of the valve panel, and adding a flow rate control. These improvements will make the system more versatile and increase its overall effectiveness.

References

1. NResearch. Part 161T011 Schematic. Drawing Number 161V251. Obtained from www.nresearch.com.
2. LabJack U12 User's Guide. 19 September 2003. LabJack Corporation. Picture obtained from www.labjack.com.
3. CB25 Circuit Board. LabJack Corporation. Picture obtained from www.labjack.com.
4. SC-206X Series User Manual. December 1996. National Instruments Corporation. Picture obtained from www.ni.com.

Appendix A: Trial

Table A1: Flow Rate Data and Analysis

Trial	Starting Volume (mL)	Final Volume (mL)	On Time (s)	Off Time (s)	Flow Rate (mL/s)
1	52.75	42.5	7.935	36.608	0.357
2	42	21.5	3.431	57.584	0.379
3	21.5	11.5	4.321	28.131	0.420
4	11.5	1.5	4.615	32.263	0.362
5	50	39	6.585	30.648	0.457
6	39	29.5	6.496	33.12	0.357
7	29.5	19	11.024	34.447	0.448
8	19	11	10.76	31.113	0.393
9	11	6	11.665	25.489	0.362
10	6	1	4.848	19.823	0.334
Average Flow Rate (ml/s)		0.387			
Average Deviation (ml/s)		0.034			
Standard Deviation (ml/s)		0.042			

Table A2: Timing Accuracy Data from Oscilloscope Reading

Trial	Width (s)	Delay (s)	% Error from log	% Error from program times
1	1.025	0.025	0.098	2.439
2	1.030	0.030	0.583	2.913
3	1.025	0.025	0.098	2.439
4	0.930	-0.070	-10.11	-7.527
5	0.930	-0.070	-10.11	-7.527
6	1.055	0.055	2.938	5.213
7	1.025	0.025	0.098	2.439
8	1.023	0.023	-0.147	2.200
9	1.025	0.025	0.098	2.439
10	1.025	0.025	0.098	2.439
11	1.130	0.130	9.381	11.50
12	0.960	-0.040	-6.667	-4.167
13	1.025	0.025	0.098	2.439
AVG	1.016	0.016	-1.042	1.327
STD	0.0526	0.0526	5.258	5.134
Time Log Report Width		1.024 s		

Appendix B: Budget

Item	Part #	Source	Qty	\$/unit	\$
NC Two-way isolation valve	161T011	www.nresearch.com	7	60.85	425.95
NO Two-way isolation valve	161T021	www.nresearch.com	1	73.05	73.05
NI Power Relay Board	SC-2062	www.ni.com	1	63.00*	63.00*
LabJack Interface	U12	www.labjack.com	1	129.00	129.00
Aluminum Panel 1/8"x4"x12"	9041K12	www.mcmaster.com	1	8.67	13.17*
Pipe Clamp	30285T35	www.mcmaster.com	2	10.00	20.00
Thumb Screw Pack	90181A595	www.mcmaster.com	1	6.37	10.87*
12V 1.5A AC/DC Adaptor	2731665	RadioShack	1	22.99	22.99
Electrical Tape	6402375	RadioShack	1	3.99	3.99
90' 22-Gauge Stranded Hook-Up Wire	2781218	RadioShack	2	5.99	11.98
CB25 Terminal Board	CB25	www.labjack.com	1	39.00	39.00
Weekendercase	629	www.plasticase.com	1	49.50	*58.68
#4-40 x 3/4" machine round head bolts	27461	Home Depot	2	0.98	1.96
Velcro	-	Home Depot	1	2.49	2.49
Rubber stoppers (22mm x 9mm)	-	Home Depot	1	1	2.49
4.5V 1.6A AC/DC Adaptor	2731760	RadioShack	1	19.99	19.99
Total (*Includes Shipping and Handling)					898.61