

# **Measurement of Tibial Translation in Dogs with Anterior Cruciate Ligament Rupture**

December 8<sup>th</sup>, 2009

Team:

Graham Bousley: Team Leader

Alex Bloomquist: Communicator

James Madsen: BSAC

Mike Nonte: BWIG

Client:

Prof. Peter Muir

Advisor:

Prof. Wan-Ju Li

**Abstract:**

Arthritis is the major cause of ACL rupture in canines and a quantitative, minimally invasive diagnostic device is needed to increase the quality of healthcare for canines as well as reduce costs. The device will measure tibial translation and force exerted on the canine's paw during the tibial thrust test. This data will be plotted and from this graph the state of the ACL will be determined. The design consists of two needles inserted at anatomical markers in line with the ACL. The distance that separates these two markers is measured by the Hall Effect sensor. In the future, a final prototype will be built and used in clinical cases and applications to humans will be explored.

## Table of Contents

Abstract .....	2
Problem Statement .....	4
Background .....	4
Current Methods of Diagnosis .....	5
Design Constraints .....	7
Previous Device .....	7
Load Cell Assembly .....	8
Hall Effect Assembly .....	10
Device in Use .....	12
Testing .....	12
Ethical Safety Concerns.....	18
Future Work .....	18
References .....	19
Product Design Specifications .....	21

## Problem Statement:

Arthritis in canines often leads to joint degeneration and rupture of the Anterior Cruciate Ligament (ACL). Diagnosis of this condition is often difficult because the current methods used are either non-quantitative and/or not cost-effective. The aim of this project is to quantify the amount of tibial translation in a canine's leg caused by a known applied force in order to determine the severity of an ACL rupture. Preliminary parts for a device that can accomplish this aim have been developed and it is the goal of this team to create and test a working model.

## Background:

Dr. Peter Muir conducts research on the Anterior Cruciate Ligament, ACL, in canines. He and his colleagues have come up with an apparatus to measure the displacement of a canine's tibia when a force is applied to the paw. This allows for an accurate reading of the severity of the ACL rupture. The ACL has an important biomechanical function; it prevents hyperextension, internal rotation and anterior-posterior translation [1]. The ACL is located between the tibia and femur in the canine knee; it can be seen in the anterior view of the canine knee (Figure 1). The ACL is labeled cranial cruciate ligament in Figure 1. ACL rupture is a common medical

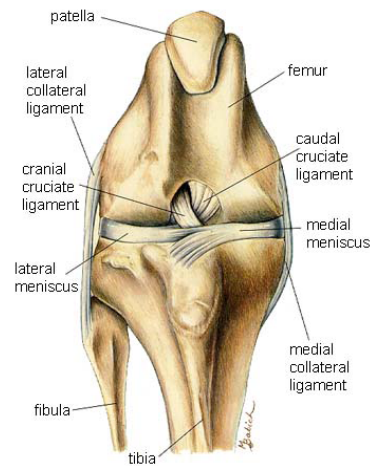
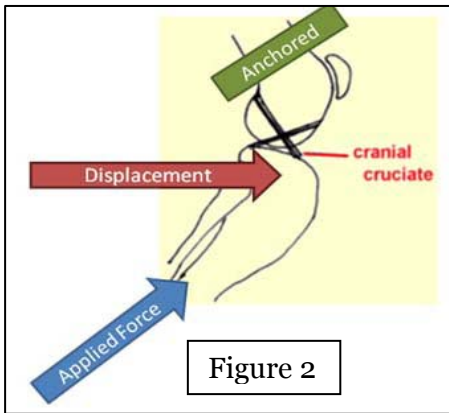

Figure 1

diagnosis in canines. Dogs with ACL rupture usually have inflammation in the synovial membrane and fluid. This inflammation deteriorates the canine's ACL gradually over time. Common, cost-effective methods of diagnosis of ACL rupture in dogs are only qualitative and must be performed by an experienced veterinarian. The diagnosis is performed by applying a

force on the paw, while holding the femur in place. This creates a displacement across the tibia and the experienced veterinarian must use his judgment on the severity of the canine's ACL rupture [2] (Figure 2).



The device design allows it to be applicable to many different-sized canines. For example, the canines can range from a Yorkshire Terrier (1.5kg) to a Mastiff (up to 100kg). The designed apparatus will allow for a quantitative measurement of the severity of the ACL rupture, leading to intervention during earlier stages of

the disease. Earlier diagnosis may help preserve ACL properties by preventing further collagen degradation [1]. This will decrease the need for ACL surgery and reduce the financial burden of ACL rupture. The anatomical markers for the placement of the needles on the device are shown (Figure 3). They are located in between the fabella and femur (#1), and between the top of the tibia and the femur(#2). An experienced veterinarian would easily find these anatomical markers.

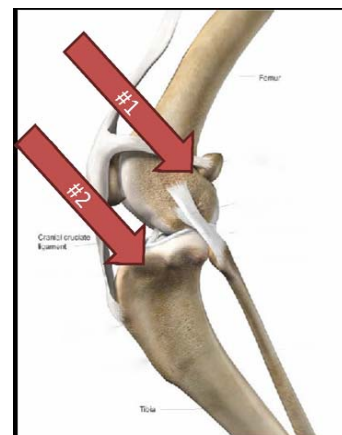

Figure 3

### **Current Methods of Diagnosis:**

Non-invasive methods of determining the presence of ACL deterioration in canines include the drawer test, the tibial thrust test, and stress radiography. To perform the drawer test, the veterinarian stabilizes the canine femur with one hand while manipulating the tibia with the other hand (Figure 4). The veterinarian subjectively assesses the extent of the forward

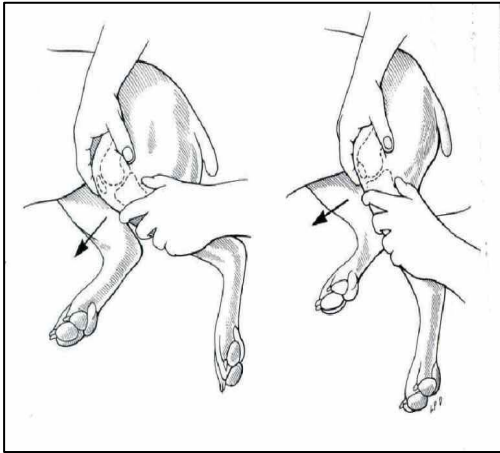

Figure 4

translation to determine if the ACL is ruptured. To perform the tibial thrust test the veterinarian stabilizes the femur with his hand while flexing the canine paw with the other hand. Again, the veterinarian assesses the extent of forward tibial translation to determine if the ACL is ruptured. Often it is necessary to sedate the canine for both tests because tension in the canine leg muscles can prevent tibial translation and thus obscure the result

of the test [3]. Diagnosis of partial ACL deterioration is difficult using these tests due to their subjective assessment of tibial translation [4].

Stress radiography may be used to assess ACL rupture. To perform a stress radiography exam, the canine femur and tibia are positioned at a 90 degree angle and a preliminary radiograph is taken. A second radiograph is taken while the examiner stabilizes the femur with his hand, pressing up on the paw to apply a maximum stress to the knee joint [4]. The ACL will not be visible on either radiograph, but a comparison of the tibia position relative to the femur can be used to assess ACL deterioration. This method of diagnosis is less favorable due to the cost of the radiographs.

Arthroscopy can also be used to assess ACL deterioration. To do this an incision is made near the knee joint and an arthroscope is inserted through the incision. The arthroscope is connected to a video screen and displays a video feed of the canine knee. Manipulation of the arthroscope allows for direct visual assessment of the extent of ACL deterioration. Drawbacks to this technique include the necessity of healing time for the canine, and the cost of the procedure is \$1700 on average [6].

## **Design Constraints:**

Our client had a few specific requirements for the device. The device must be able to secure to the anatomical landmarks of a canine's leg and measure the amount of displacement in the tibia effectively. This first requirement is the most basic requirement of the device, as the measurement of tibial translation is the way that veterinarians recognize an ACL tear. Next, the Hall Effect sensor and magnet system must stay in the same plane during the measurement. This must happen because it will undermine the data if those two components are not in the same plane. The sensitive range of this device must be within 1-10mm, as this is the area our client is concerned about in terms of tibial translation. The device should not cause any serious harm to the canine's leg. The device must be as inexpensive as possible while still obtaining optimal data that is repeatable and accurate. Lastly, the device must have an internalized system to increase accuracy and cleanliness, because it will be used in a clinical setting.

## **Previous Device:**

The previous component of the device being used to measure forward displacement of the tibia consists of two hypodermic needles attached to a metal rod (Figure 5). One needle is fixed in place while the other is free to slide along the metal rod. The needles are placed in the aforementioned specific

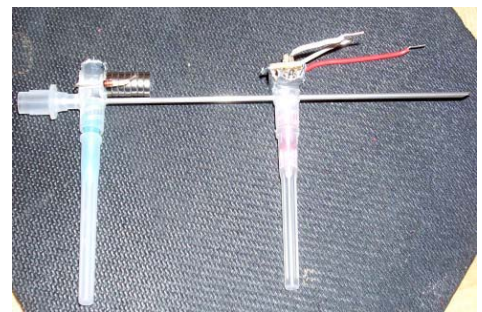

Figure 5

anatomical markers in the canine knee. These anatomical markers are easily recognizable by a veterinarian so placement of needles is highly repeatable. A powerful magnet is mounted on the fixed needle while the Hall Effect sensor is mounted on the mobile needle. As the tibia displaces forward, the needles move closer together, moving the Hall Effect sensor closer to the magnet.



Figure 6

This causes a measurable change in voltage output of the Hall Effect sensor which can be related to the displacement of the needles.

The component of the device being used to measure the force applied to the canine paw consists of two plastic plates with a Velcro strap (Figure 6). A load cell will be embedded between the two plastic plates. This component is strapped to the canine paw when the veterinarian applies a force while performing the tibial thrust test. The load cell will measure

the force being applied to the canine paw.

**Load Cell Assembly:**

The torsion single point load cell is a device that measures applied torque. This is

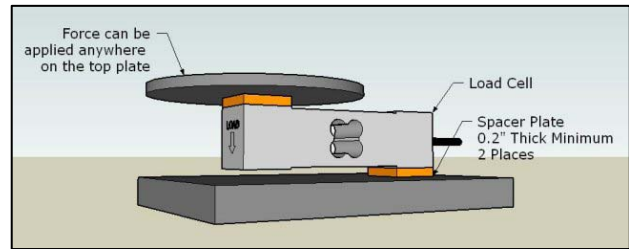

Figure 7

done by fixing one end and applying a force to the other end (Figure 7). The load cell gives a specific output voltage based upon a given force applied to it. We have collected consistent voltage data ( $R^2 \approx .999$ ) up to a load of 10 kg (98.1 N), which far exceeds the 15 N necessary for the canine ACL rupture test (Figure 8).

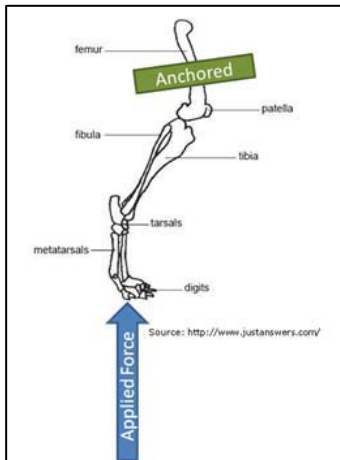

Figure 8

For our purposes, we

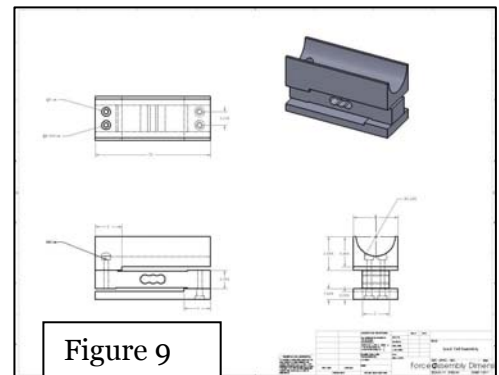

Figure 9



will use the load cell to collect data on the amount of force applied to a canine's leg. During the ACL rupture examination, the canine's leg will be anchored at the femur and force will be applied at the paw and measured by the amount of torque the force plate creates on the



Figure 10

body of the load cell (Figure 9).

The force assembly consists of three main parts: the load cell, base and foot holder (Figure 10). The base and foot holder are constructed out of 1/2" Lexan polycarbonate sheet. The foot holder was fabricated by cementing four 1/2" Lexan sheets together and then 2D

CNC milling it to create the cylindrical cut-out. A portion of both base

and foot holder were milled flat in order to provide room for the flexion of the load cell itself.

The load cell is attached to the base and foot holder by four M6 Allen head bolts.

The use of Lexan in the design was somewhat arbitrary due to the lack of constraints imposed on the design. Most hard plastics would be suitable for the design because there are very low amounts of force involved. The Velcro strap incorporated in the previous design was determined useless during cadaver testing and is therefore not included in the final design.

### Hall Effect Assembly:

The device we have chosen for measuring the distance of the tibial translation is a Hall Effect sensor. The circuit only consists of a  $1k\Omega$  resistor, the Hall Effect sensor and a 6V zener diode. The resistor in the circuit provides current protection and the zener diode provides voltage protection across the sensor. All of the testing was done at an input voltage of 15V. As the magnetic field passes through the Hall Effect sensor, the output voltage is adjusted to the field intensity.

The final design of the device containing the Hall Effect sensor utilized a flat aluminum bar for stability and to prevent unwanted moments about the bar. Three separate holes were cut into the aluminum bar, two for the supporting rods, and one for the adjustable needle. On the dorsal ends of the aluminum rod two  $7/16'$  nuts were

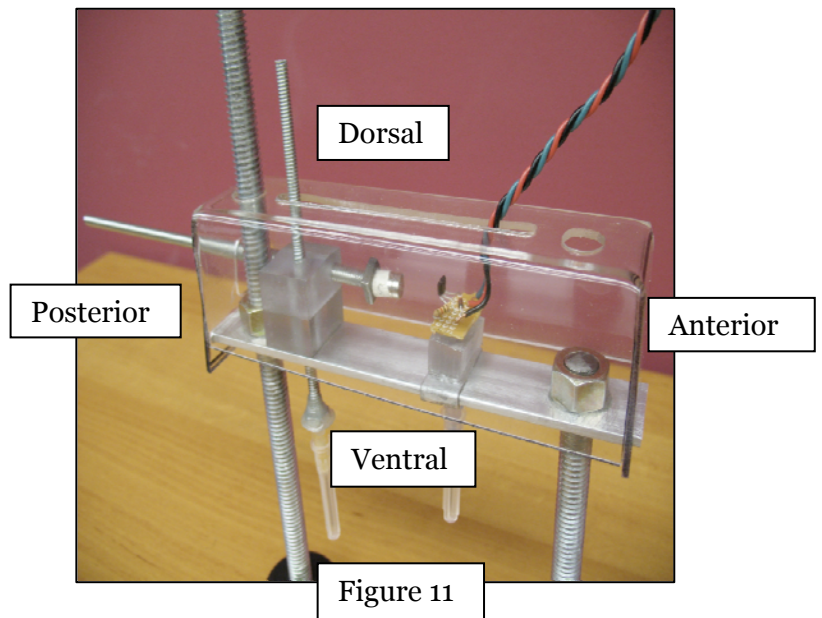

glued to allow for adjustable supporting arms (Figure 11). The supporting arms also had pads glued to the end of them to allow more surface contact. The supporting rods rested on the lab table and canine leg accordingly. They kept the needles placed in the anatomical markers from penetrating too deep into the canine. The third hole was for an adjustable needle rod with a tapered tip that attached to the needle within the patellar tendon. Using tapered tips to attach to the previously placed needles at the anatomical markers enabled ease of use and cleaning. By implementing an adjustable needle our device was more versatile and ensured the aluminum bar would be kept level during the experiment, unlike the original design.

Housing the adjustable needle rod and adjustable magnet rod was a Lexan cube. This Lexan cube had two tapped holes, one dorsal to ventral and one anterior to posterior. These 10-24 holes were cut with a drill press and then tapped with a tap handle. The dorsal to ventral hole housed the adjustable needle rod, and the anterior posterior hole housed the adjustable magnet rod. The adjustable magnet rod enabled the magnet distance from the Hall Effect sensor to be calibrated before each test.

The Hall Effect sensor was mounted on an aluminum slider. The slider and bar were polished with steel wool and lubricated to greatly reduce friction. The bar and slider design only allowed movement in the posterior to anterior direction. Thus, during testing the slider was displaced creating quantitative data from the Hall Effect sensor. Mounted on the ventral side of the slider was a tapered attachment point for the needle placed at the fabella. During the tibial thrust test, a force was applied to the paw displacing the anatomical markers. This displacement was measured by the change in voltage in the Hall Effect sensor as the magnet and sensor became farther apart throughout the test.

Finally, a case was added to the device to increase repeatability of data by removing the chance for internal changes during testing. A 9 Volt battery was used for ease of portability to power the circuits on the device. The data was acquired by a DAQ card and inputted into LabView for analysis (Figure 12).



Figure 12

**Device in Use:**

An experienced technician placed the needles at the anatomical markers, the fabella and the patellar tendon. Then the adjustable supporting rods were calibrated so that the device was level. One supporting rod was lowered to the procedure table and the other was lowered to the canine's upper leg. Then the fabella needle was attached to the tapered tip on the bottom of the slider, and the patellar tendon needle was attached to the tapered tip on the end of the adjustable needle rod. The distance between the magnets and Hall Effect sensor on the slider was measured to 7mm. This distance was achieved by moving the adjustable magnet rod to the determined distance. Power was supplied to both the Hall Effect and load cell device by 9V batteries.

The load cell device was held against the bottom of the tarsal, and the tibial thrust test was performed as described in current methods. This recorded force caused a displacement in the anatomical markers and voltage reading from the Hall Effect sensor. Data was sent to a DAQ card and recorded in LabView for analysis.

**Testing:**

The goal of the preliminary phase of testing was to determine the relationship between the voltage output of each device and the physical quantity (displacement or force) that each device was intended to measure. To test the load cell device, objects of known mass were placed in the cradle of the device (where the canine tarsal is placed) and the voltage output of the device was measured. This was done for 26 data points with forces ranging below (0.981 N) and above (25.5 N) the 10-15 N range in which the device must be sensitive. (Figure 13) shows the results of testing along with an equation of fit. The equation of fit has an  $R^2$  Value of 0.9999 which

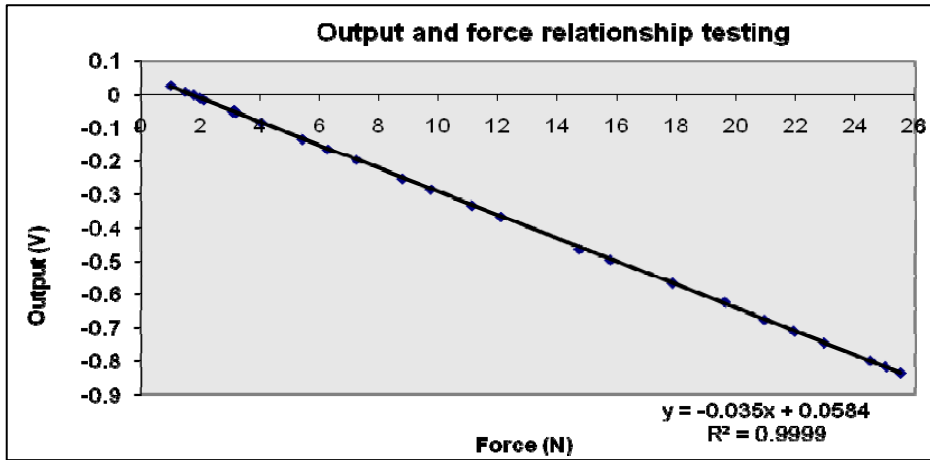

Figure 13

indicates that there is a strong linear relationship between the force applied to the force measuring device and the output produced by the device.

Testing of the

Hall Effect device consisted of placing the Hall Effect sensor and magnets to known distances from one another, then measuring the output of the device. The device was tested with the south pole of the magnets facing the Hall Effect sensor first and then with the north pole of the

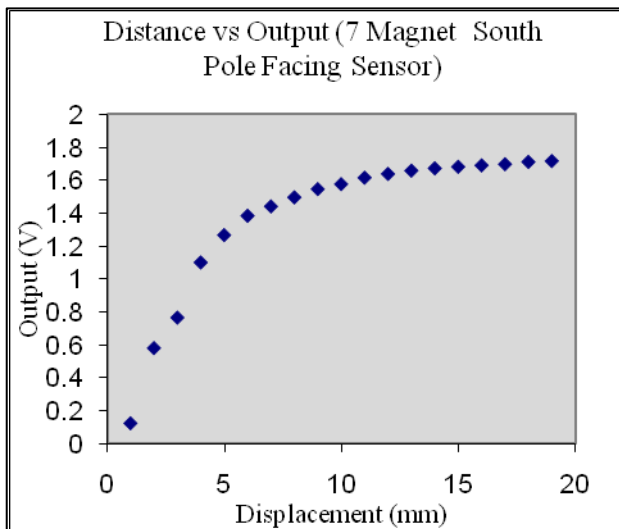

Figure 14

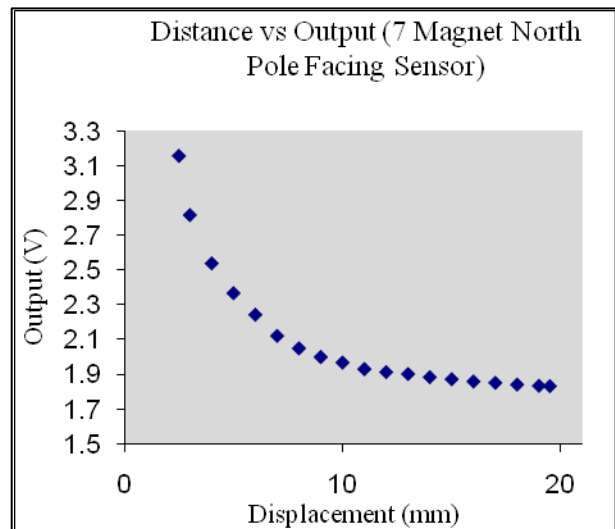

Figure 15

magnets facing the sensor to determine if this would change the output of the device. (Figure 14) and (Figure 15) display the results of these tests.

As can be seen in the graphs, the pole configuration of the magnets changes whether the output increases or decreases with increasing displacement. Also, the sensitive range of output for the south pole configuration is close to 1.59V while the sensitive range of output for the north pole configuration is close to 2.46 V. Based on the greater sensitive range output and thus greater sensitivity to displacement of the Hall Effect sensor, we decided using the north pole arrangement would be best for the purposes of this device. During testing the number of magnets used was also varied to determine if a fewer number of magnets could be used while

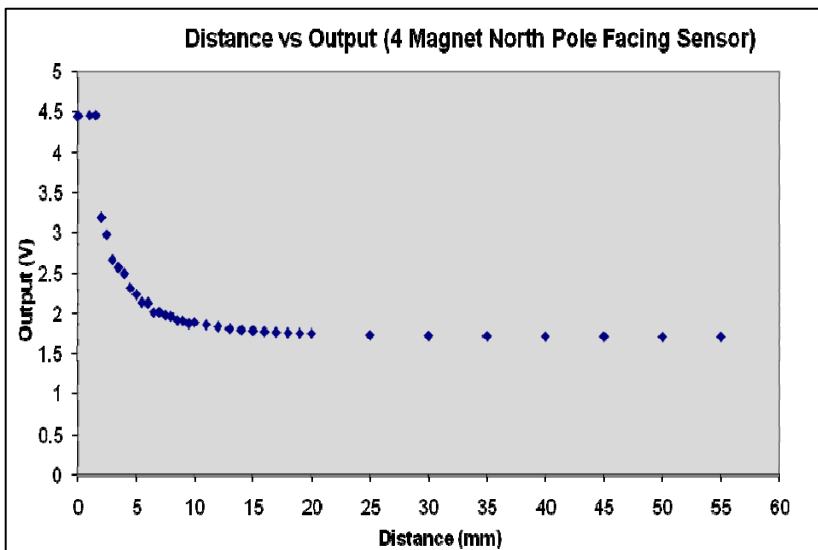

Figure 16

still maintaining a strong enough magnetic field to overcome signal noise. (Figure 16) displays the results of a test with four magnets and north pole magnet configuration.

Comparing the data displayed in Figure 16 with that of 15 shows that the sensitive output range of the Hall Effect sensor is

still close to 2.5V and the data does not show any significant deviations due to signal noise. The first three data points occur at the same output value due to the maximum output of the device being close to 4.5V. If the device is calibrated to a starting displacement of magnets and Hall Effect sensor of 7mm, the Hall Effect sensor will never move close enough to the magnets during a test on a canine to produce an output in the maximum range of the device. This will prevent information regarding displacement from being lost due to ambiguity caused by a maxed out

voltage output. Based on its sensitivity and ability to overcome signal noise, a four magnet North Pole configuration was chosen for canine testing.

Testing of the devices on the canine occurred according to the procedure outlined in the device in use section. Five trials were performed using the displacement device on a canine with an intact ACL. Five trials were performed using the displacement device on the canine's same leg after the ACL was artificially ruptured. The LabView software was configured to record output data for a ten second period. During this ten second period a veterinarian manipulated

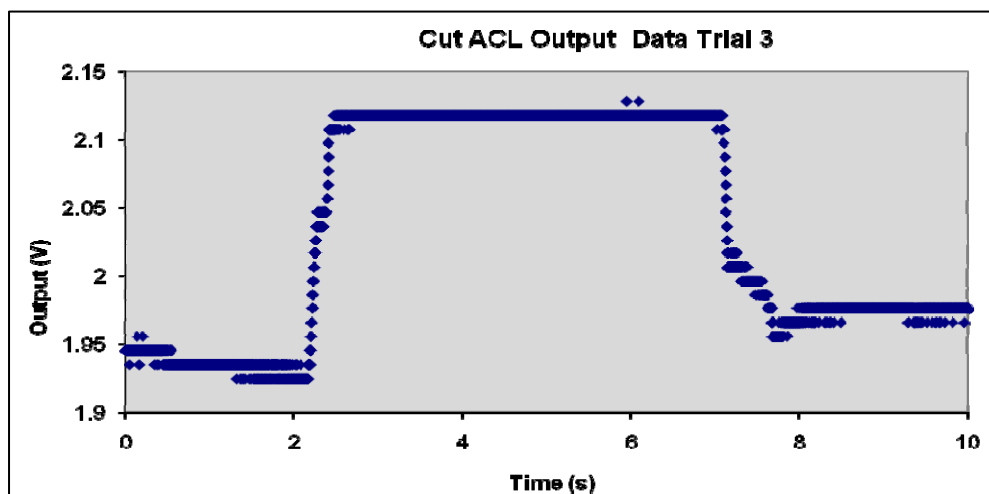

Figure 17

the canine tarsal from a rest position to full flexion, held the tarsal in full flexion for a few seconds, then returned the tarsal to a resting

position. An example of the recorded data for one trial of the ruptured ACL can be seen in (Figure 17).

The data displayed in Figure 17 follows the veterinarian's actions closely. The output begins at a lower value then increases to a maximum as the tarsal enters full flexion. The voltage output at full flexion is very stable, and then returns again to a lower value as the tarsal returns to a resting position.

The maximum output value was found for each trial of the intact and ruptured ACL. Using the relationship between output and displacement depicted in Figure A4 and the maximum output values, the maximum displacement for each trial was determined. The maximum displacement for the intact knee and the maximum displacement for the ruptured knee were averaged. A comparison of the two averages along with error bars depicting one standard deviation can be seen in (Figure 18).

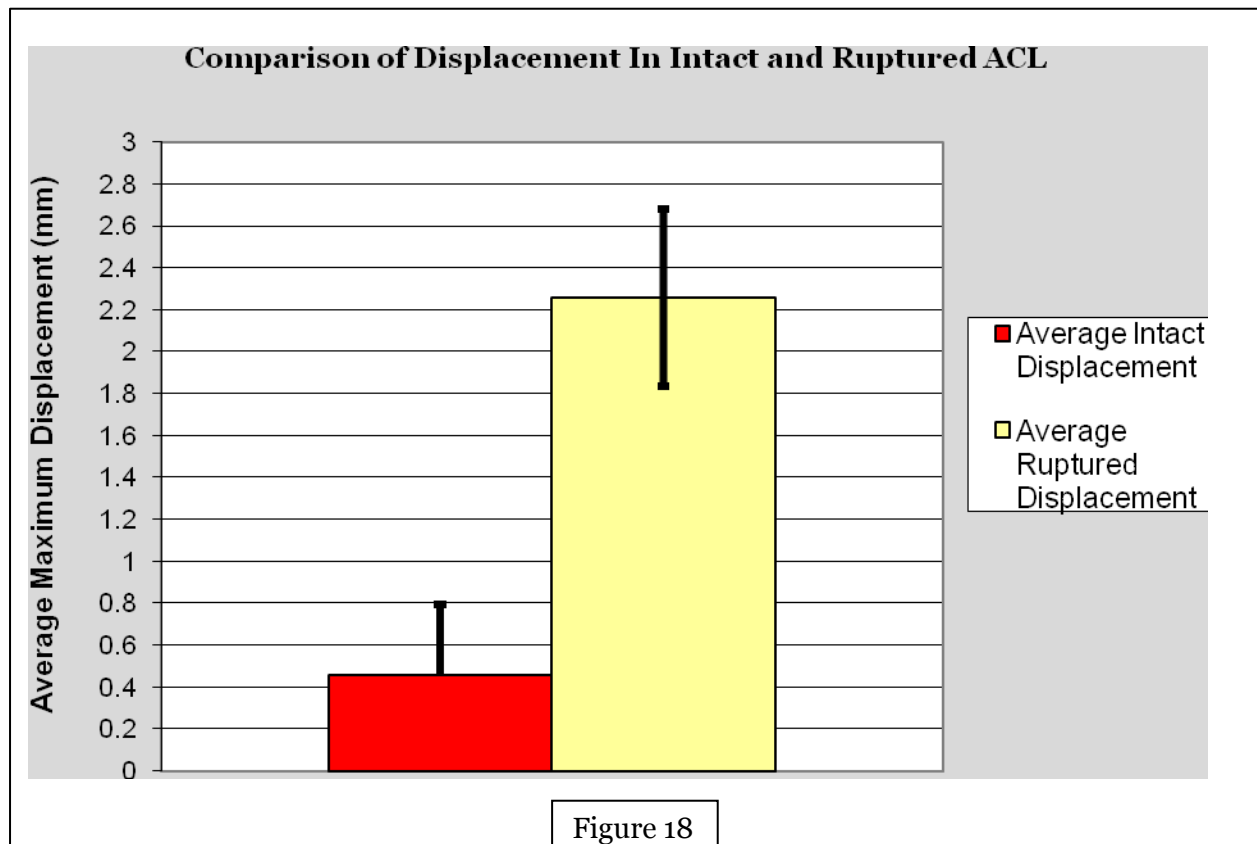

Figure 18

As can be seen in Figure 18, the average maximum displacement of the ruptured knee (2.257 mm) was noticeably greater than that of the intact knee (0.454 mm). The standard deviation for the average ruptured displacement was 0.420mm and the standard deviation for the average intact displacement was 0.381mm. This indicates that the difference between the



average maximum displacement of the ruptured knee and that of the intact knee is greater than four standard deviations. Based on these findings, it is reasonable to conclude that the displacement device is sensitive enough to detect the difference between an intact ACL and ruptured ACL.

Testing of the force measuring device on the canine occurred according to the procedure outlined in the device in use section. Five trials were performed using the canine leg with intact ACL and five using the leg once the ACL had been artificially ruptured. Again the LabView software recorded the output of the device for a ten second period. (Figure 19) depicts the results of one of these trials.

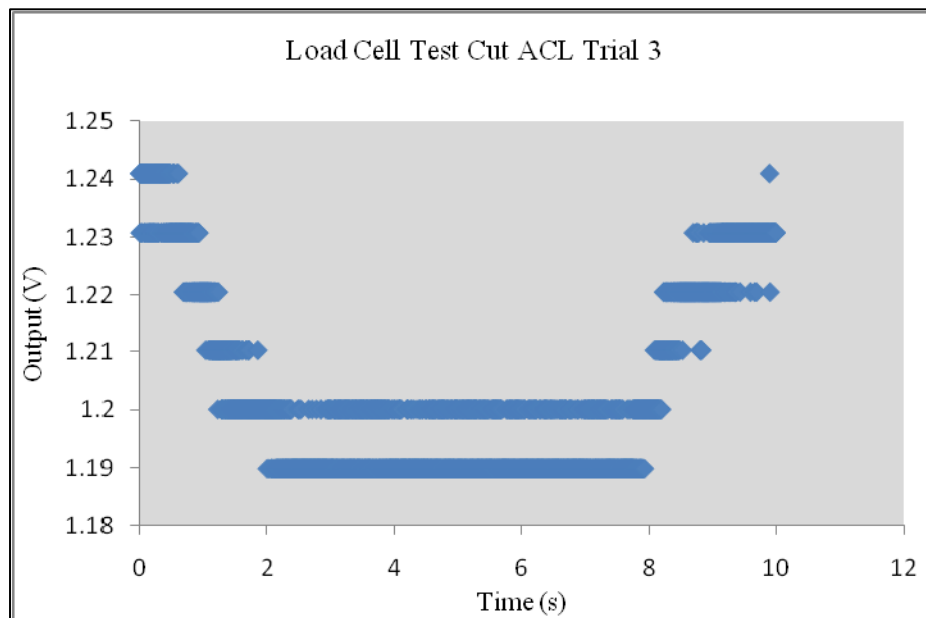

Figure 19

As the veterinarian applied force to the canine tarsal, the voltage output decreased as predicted by preliminary testing of the device. As the veterinarian held the tarsal in place for a few seconds at full

flexion, the output stayed constant. The presence of two lines of minimum output in Figure 19 is a result of small fluctuations in the force applied by the veterinarian rather than instability of device output. Force applied by the veterinarian does not vary when the ACL is ruptured; diagnosis of rupture is based on differences in displacement. Based on the output behaving as

expected and the lack of significant signal noise, it seems the force measuring device can be used in future cadaver testing.

### **Ethical/Safety Concerns:**

During construction of our device, no major ethical concerns were established. However, the device will be used in a clinical setting and we must consider how the device will interact with canines and personnel operating the device.

The needles placed at the anatomical markers as described above may be a safety concern. But the needle will only be handled by experienced personnel. According to Dr. Peter Muir the procedure for placing the needles is standard and safe.

The power supply may also be a safety concern for this device. But, because the power supply is only coming from a 9V battery to power both the load cell and the Hall Effect devices, there is little danger in handling them.

### **Future Work:**

Though there have been many improvements over the semester, there is also a lot of work to be done. This includes designing a more ergonomic force assembly, adding measurements to the Hall Effect assembly's case, developing a more easily set up data acquisition method, improving the robustness of the design and reducing friction on the slider.

Designing a more ergonomic force assembly is important because the base is being held by the technician using. Its rectangular design could possibly induce fatigue after prolonged use, which

could reduce accuracy and repeatability. Adding measurements to the case is necessary in order to adjust the needle mounts and magnets accurately as they are moved from dog to dog. It is also important for data acquisition. Probably the most useful future work to be accomplished is the simplification on electronics and data acquisition methods. These should be a high priority because if setup is simpler, easier and faster, more testing can be accomplished in less time. This is important because the more data the better when it comes to determining the theoretical ranges of values for normal, partially ruptured and fully ruptured anterior cruciate ligaments. Robustness is more important for a final product than it is now, but more time spent fixing it means less time testing with the device. Hopefully in the future epoxies, cements, and glues will be avoided in the construction of the design. Reducing friction on the slider will help improve accuracy between force applied and the stretch of the ligament and the less interference there is with these two forces, the better.

## References:

1. DeRooster et. Al. "Morphologic and Functional Features of the Canine Cruciate Ligaments ". Veterinary Surgery. 2006.
2. Harasen, Greg. "Diagnosing rupture of the cranial cruciate ligament". Animal Clinic of Regina. 10/18/2009 <<http://www.ncbi.nlm.nih.gov:80/pmc/articles/PMC339306/>>.
3. Veterinary Sports Medicine  
[http://www.vetsportsmedicine.com/newsAndEvents/documents/Proof\\_CCLInjurya.pdf](http://www.vetsportsmedicine.com/newsAndEvents/documents/Proof_CCLInjurya.pdf).  
Accessed 9/15/09.
4. DeRooster, H., VanBree, H (1999). Use of compression stress radiography for detection of partial tears of the canine cranial cruciate ligament. Journal of Small Animal Practice. Volume 40, Issue 2, Pages 573-576.
5. Dog Knee Injury. <http://dogkneeinjury.com/2008/drawer-sign-test-and-tibial-compression-exam>. Accessed 9/15/09.
6. Veterinary Sports Medicine  
[http://www.vetsportsmedicine.com/resourceCenter/veterinarian\\_lessmore.html](http://www.vetsportsmedicine.com/resourceCenter/veterinarian_lessmore.html)  
Accessed 9/15/09

# **Product Design Specifications for BME 301 Group 8: Measurement of tibial translation in dogs with anterior cruciate ligament rupture (tibial\_measurement)**

Group Members: Alex Bloomquist, Graham Bousley, James Madsen, Mike Nonte

## Problem Statement:

Arthritis in canines often leads to joint degeneration and rupture of the Anterior Cruciate Ligament (ACL). Diagnosis of this condition is often difficult because the current methods used are non-quantitative. The aim of this project is to quantify the amount of tibial translation in a canine's leg caused by a known applied force in order to determine the severity of an ACL rupture. Preliminary parts for a device that can accomplish this have been developed and it is the goal of this team to create and test a working model.

1. Design Requirements: The device must meet all of the client requirements
  - a. Performance Requirements: The device must be able to secure to the anatomical landmarks of a canine's leg and measure the amount of displacement in the tibia effectively. The Hall Effect sensor and magnet system must stay in the same plane during the measurement.
  - b. Safety: The device should not cause any serious harm to a canine's leg.
  - c. Accuracy and Reliability: Data obtained from testing should be repeatable so that the device may be accurate when used in clinical testing. Hall Effect sensor should be accurate at 15V of input voltage.

- d. Life in Service: The device should last for 10 years.
  - e. Shelf life: The device should have a shelf life of 5 years.
  - f. Operating environment: The device should withstand room temperature and be easily cleanable so that it can be as sterile as possible.
  - g. Ergonomics: A trained veterinarian should operate the device.
  - h. Size: The device should not be big so that it will not cause injury to the canine.
  - i. Weight: The device must not weigh more than 15 grams.
  - j. Materials: The device must be made of sterile and lightweight materials so that the canine will not be injured when the ACL rupture test is performed with the device.
  - k. Aesthetics, Appearance, Finish: The device must have an internalized system to increase accuracy.
2. Production Characteristics:
- a. Quantity: One working unit is necessary to quantify tibial translation.
  - b. Target Product Cost: As cheap as possible for mass-production.
3. Miscellaneous:
- a. Standards and Specifications: Approval from a medical organization.
  - b. Customer: Veterinarians should be able to use this easily.
  - c. Patient-Related Concerns: The device should be sterile and the system must be properly internalized so the canine is not caused any harm.
  - d. Competition: The model is similar to an arthrometer for humans. X-ray is a good qualitative method but it is expensive and non-quantitative.