

# **The Effects of Repeated Depression on Air-Filled Bulbs Used in Tongue Exercises for Swallowing Problems**

## **Final Report**

December 8, 2010

### **Team Members**

Sarah Reichert: Team Leader

John Byce: Communicator

Katherine Lake: BWIG

Chris Besaw: BSAC

### **Clients**

Dr. JoAnne Robbins

Ms. Jacqueline Hind

### **Advisor**

Professor John Webster

## **Abstract**

Our clients, Dr. JoAnne Robbins and Jacqueline Hind, are specialists in swallowing and geriatrics. They have created an exercise protocol to strengthen lingual muscles in patients with swallowing difficulties and disorders. The regimen incorporates the utilization of an Iowa Oral Performance Instrument (IOPI) and attached air-filled bulbs. Some of their patients expressed difficulty using the bulbs throughout the eight weeks of exercise that constitute the protocol. In response, our clients proposed that we investigate if the bulbs are changing with use, identify the factors causing the change if one is present, and redesign the bulbs to eliminate this change. We tested bulbs used for exercise with consistent compression and force values and determined that the output pressure varies over time. Throughout the eight weeks of testing, compressing the bulbs to the same extent and applying the same amount of force to them yielded lower pressure values than those obtained initially for bulbs that had not yet been used for exercise. Furthermore, we conducted an underwater leak test that suggested that the failure of the bulbs might arise from either air leakage from the connection points in the system or the viscoelastic nature of the bulbs themselves. Finally, we redesigned the tubing connections in order to pinpoint and eliminate the exact cause of failure observed in our rigorous testing.

## Table of Contents

<b><u>Abstract</u></b>	2
<b><u>Background</u></b>	4
<i>Client Description</i>	4
<i>Dysphagia</i>	5
<i>The Iowa Oral Performance Instrument (IOPI)</i>	6
<i>Bulb Material</i>	7
<b><u>Current Devices</u></b>	8
<b><u>Problem Motivation</u></b>	9
<b><u>Design Requirements</u></b>	10
<b><u>Testing Apparatus Design Alternatives</u></b>	11
<i>Force Apparatus</i>	11
<i>Compression Apparatus</i>	12
<i>Instron Electromechanical System</i>	14
<b><u>Testing Apparatus Design Matrix</u></b>	15
<i>Precision</i>	16
<i>Cost</i>	16
<i>Scope of Testing</i>	17
<i>Imitation of Clinical Use</i>	17
<i>Variability for Testing Conditions</i>	18
<b><u>Exercise Regimen</u></b>	18
<b><u>Preliminary Testing</u></b>	20
<i>Compression and Force Testing</i>	20
<i>Water Absorption Testing</i>	24
<i>Underwater Squeeze Testing</i>	25
<b><u>Tubing Design Alternatives</u></b>	26
<b><u>Tubing Design Matrix</u></b>	28
<i>Gas Permeability</i>	28
<i>Cost</i>	29
<i>Feasibility</i>	29
<i>Connection Reliability</i>	30
<b><u>Tubing Prototype Construction</u></b>	30
<b><u>Final Design Testing</u></b>	31
<i>Underwater Clamp Tests</i>	31
<i>Simulated Exercise Test</i>	33
<b><u>Time Management</u></b>	34
<b><u>Costs</u></b>	35
<b><u>Future Work</u></b>	36
<b><u>References</u></b>	39
<b><u>Appendix</u></b>	41

## **Background**

### ***Client Description***

Dr. JoAnne Robbins is the Associate Director of Research for the Geriatric Research, Education, and Clinical Center (GRECC) at the William S. Middleton Memorial Veterans Hospital in Madison, Wisconsin<sup>1</sup>. Her research focuses on how age-related diseases and normal aging affect swallowing ability. She is also investigating how therapeutic treatments can be incorporated in order to delay or prevent swallowing disorders and the potentially life-threatening effects they can have<sup>2</sup>. Dr. Robbins is a Professor in the Department of Medicine at University of Wisconsin – Madison School of Medicine and Public Health. She is also an Affiliate Professor in the departments of Biomedical Engineering, Radiology, and Nutritional Sciences<sup>1</sup>.

Jacqueline Hind is a Board Recognized Specialist in Swallowing and Swallowing Disorders. She serves as an Outreach Program Manager and Coordinator for the Swallowing Speech and Dining Enhancement Program at GRECC. She has been working to treat patients with swallowing disorders for over 15 years<sup>1</sup>.

Throughout our clients' careers, they have published work in numerous peer-reviewed journals and patented inventions through the Wisconsin Alumni Research Foundation (WARF)<sup>1</sup>. Some of their current work pertains to an exercise regimen they developed to help increase lingual muscle strength and improve swallowing ability. Patients undergoing the protocol have been reporting difficulty achieving the appropriate exercise values over the course of the therapy. Consequently, our clients have proposed that we investigate aspects of the device used for the regimen to determine whether or not it is changing as a result of exercise.

## ***Dysphagia***

Dysphagia, or difficulty swallowing, is a prevalent and hazardous medical symptom that is detrimental to suffering patients worldwide. An estimated 40% of adults 60 years and older experience symptoms of dysphagia<sup>3</sup>. This harmful condition results from weakened muscles in the tongue and cheek or the inability to begin muscle contractions to initiate swallowing altogether<sup>4</sup>. Underlying causes of muscle weakness are generally age-related sarcopenia, which is the loss of muscle mass due to normal aging, or repercussions of prior health conditions, including stroke, Parkinson's disease, cerebral palsy, and head, neck, and esophageal cancer. Various underlying diseases are not only precursors to dysphagia, but they also increase the mortality rate of dysphagia-related conditions. Strokes and Parkinson's disease, for example, have both been perceived to heighten the rate of mortality due to aspiration pneumonia. Pneumonia, resulting from the bacterial growth produced by food or liquid aspirated into the lungs, is the most fatal consequence of dysphagia. This complication is the fifth leading cause of death in adults over 65 years old, and third in adults 85 and older<sup>3</sup>. Other detrimental complications that result from dysphagia include dehydration and malnutrition, which are both induced by the inability to swallow necessary foods and liquids. Extreme discomfort and highly limited diet are also associated with this condition.

Current treatments of dysphagia are centered upon prescribed behavioral strategies that minimize risk while increasing swallowing comfort. Among these strategies are dietary modification, thickening of liquids, moistening of dry foods, and reduction of bolus size<sup>3</sup>. Although these prescribed methods can be largely effective in preventing aspiration and increasing comfort, they are unable to improve the swallowing mechanism itself. The human swallow is governed by signaling of the sensorimotor neuronal network and the musculature it

ultimately controls<sup>5</sup>. Recent studies conducted by Dr. Robbins have proven that swallowing function can be improved by strengthening the lingual musculature. Furthermore, these studies prove that lingual strength can directly be improved through repetitive exercise, similar to muscle strengthening exercises commonly executed for extremities. Significant improvements in both isometric lingual pressure and maximum lingual strength can occur in as little as eight weeks of exercise. Increased strength and pressure can, in turn, dramatically improve swallowing ability and reduce risks associated with dysphagia<sup>5</sup>. Lingual exercise regimens are currently executed using lingual pressure sensing systems, such as the Iowa Oral Performance Instrument (IOPI), which provide visual feedback as patients firmly press their tongues to the roof of their mouths.

With an exponentially increasing population of elderly in our nation, the negative effects of the already fatal dysphagia-related complications will likely increase dramatically. Further development and implementation of treatments that increase the functionality of the swallow, such as lingual exercise, are pivotal in the prevention of dysphagia symptoms.

### ***The Iowa Oral Performance Instrument (IOPI)***

The device used by our clients' patients is called the Iowa Oral Performance Instrument (IOPI), and is shown in Figure 1. This device provides a way to measure lingual strength objectively and gives immediate feedback to the patient and doctor. Tongue strength during tongue elevation, protrusion, and laterally directed movements can be measured as well as lip compression strength and fatigability of the tongue and lips. Tongue strength is measured by pressing the bulb against the palate as hard as possible, resulting in a digital pressure readout on the IOPI. Lip compression strength can be found by placing the bulb between the lips and applying a maximum amount of pressure. Fatigability is calculated by applying 50% of a

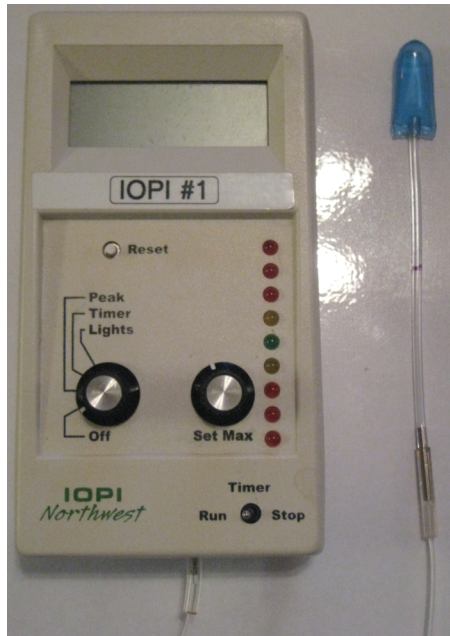

**Figure 1: Picture of an IOPI.**  
The air-filled bulb on the right side of the picture is compressed with the tongue, and the measured pressure is displayed by the device on the left side of the image.

patient's maximum pressure for as long as possible. The IOPI consists of an electronic system that contains controls and digitally displays pressure readouts in kilopascals. This system contains a set of lights that display the increasing percentages of the maximum pressure. The bulb that is placed in a patient's mouth is made of polyvinyl chloride (PVC) and is attached to the device by clear vinyl tubing<sup>6</sup>. The IOPI is also used in the eight-week exercise regimen that our clients prescribe to their patients. The patients exercise with the device three times per day, three days a week. A single exercise session entails one set of ten repetitions for both the anterior and posterior parts of the tongue. Each repetition consists of pressing the bulb to the palate and holding for three seconds at a particular percentage of the maximum tongue strength. For the first week, the patients exercise at 60% of their maximum, and for the remaining weeks the device is set for 80% of the maximum.

### ***Bulb Material***

The material used in the air-filled bulb attached to the IOPI device is polyvinyl chloride (PVC). PVC has many applications, ranging from medical devices to packaging. PVC is cheap, safe, and durable, which has led to its widespread use. The safety of any product is essential and especially important when it is being used in healthcare, and PVC is one of the safest materials being used today. It is chemically stable, inert, and does not undergo any changes in composition or properties that could end up being dangerous to patients using this plastic<sup>7</sup>. PVC is also

durable and resistant to change; it has a maximum temperature usage of around 60 °C, and is resistant to most dilute acids and bases<sup>8</sup>. PVC is, however, permeable to gases when plasticizers are added to soften it, which is a major concern in the application of pressure readouts on the IOPI device. In order to achieve an accurate reading, there must be a consistent amount of air in the bulb. If there is an air leakage after a certain number of uses, then the pressure readouts could be affected. It has been shown that PVC permeability is strongly dependent on the plasticizer used in the manufacturing process<sup>9</sup>. The bulbs used in conjunction with the IOPI device are made through a dip casting method, which consists of a mold being coated with a plastic and a particular plastisol and cured<sup>10</sup>. Therefore, using a plastisol with a lower gas permeability could help to control air leakage.

### **Current Devices**

Few devices used for an oral exercise regimen presently exist. Our clients currently have their patients use the Iowa Oral Performance Instrument for lingual muscle exercises. The IOPI, as described earlier, utilizes an air-filled bulb attached to a device that measures pressure<sup>6</sup>. When the tongue exerts force on the bulb, a pressure reading is displayed on the handheld device.

The Madison Oral Strengthening Therapeutic Device consists of an oral mouthpiece attached to a handheld device used to measure the force exerted on the mouthpiece<sup>11</sup>. Unlike the IOPI, the Madison Oral Strengthening Therapeutic Device uses a pressure sensor that is able to simultaneously measure pressure exerted in multiple areas within the oral cavity<sup>11</sup>. This device is still under development by our clients and is therefore unavailable for use in lingual strengthening exercises at this time.

Our clients also patented an oral-lever resistance exercise device. The device is comprised of an upper and lower lever attached at a pivot with a resistance element to enable it



to be used for oral exercise<sup>12</sup>. Isotonic and isometric exercises are permitted by the device, and the level of resistance can be altered by changing the resistance element. Suggested resistance elements are elastic bands or springs<sup>12</sup>. See Figure 2 for a detailed drawing of the device.

This device is currently in use by our clients, but cannot be used to measure the amount of pressure produced during exercise.

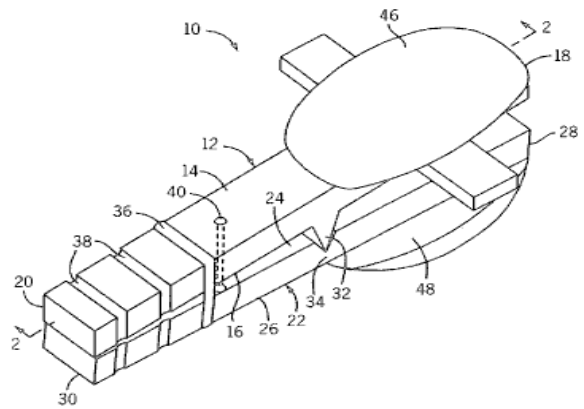

**Figure 2: Drawing of an Oral-Lever Resistance Exercise Device<sup>12</sup>.**

Different elastic bands can be placed around the grooves, indicated by the numbers 36 and 38, in order to increase or decrease the resistance. The patient then compresses the device by exerting pressure on the surface indicated by number 46.

### **Problem Motivation**

Dysphagia is a condition that affects over six million elderly people in the United States alone, and leads to a drastic decrease in quality of life and, in some cases, death<sup>4</sup>. Difficulty or discomfort while swallowing can lead to a decrease in motivation to eat, loss of weight, or the aspiration of food into the lungs<sup>13</sup>. The average male subject can produce a tongue pressure reading of approximately 65 kPa on the Iowa Oral Performance Device (IOPI), while healthy elderly persons have strengths between 40 and 55 kPa. There is no clear-cut value that determines whether a person is considered ‘weak’, but any value under 30 kPa has a high probability of needing improvement<sup>6</sup>. There exists a clear correlation between lingual strength and swallowing ability, resulting in the need for various devices and exercise programs to increase the strength of these muscles<sup>14</sup>. Our clients have their patients use the IOPI as part of an eight-week exercise regimen to increase lingual capacities. This regimen consists of connecting the device to a bulb that is placed in the mouth as pressure from the tongue is applied by the patient, giving digitally displayed pressures in kilopascals. Patients have been reporting a

decrease in bulb performance after two weeks of use. Our clients have asked us to determine whether this is simply a psychological belief of the patients or an actual change resulting from an air leakage or change in material properties of the bulb. We were also assigned the task of suggesting and fabricating a solution to any observed failures in the pressure sensing system.

### **Design Requirements**

The design requirements governing this project are outlined in the Project Design Specifications in the Appendix, and are explained in detail here. The device must not harm the mouth, tongue, or throat, as it will be placed in the oral cavity between the palate and tongue during exercise. All materials must be nontoxic and comply with the standards of the Food and Drug Administration (FDA).

In addition to essential safety requirements, the design must also meet a set of performance standards set forth by our client. The final design of our device should have a life in service of the duration of the exercise regimen, which is eight weeks or approximately 1,500 compressions. The bulb should not change in elasticity or ability to measure force during the exercise regimen. The device must also function at the normal temperature of the oral cavity, 37 °C. In the absence of compression of the plastic or environmental disruptions such as extreme heat (greater than 30 °C), extreme cold (less than 5 °C), or significant humidity (greater than 75%) the product's functionality is not expected to decline.

The device must also provide accurate and precise measurements. Consistent readings are essential so the patients can maintain exercise pressures in accordance with their exercise programs. Failure to measure exerted force precisely may result in the patient using an incorrect force to exercise. Failure to use adequate force during exercise could result in a decreased rate of

tongue strength improvement, while excessive force exerted during exercise could cause fatigue or excessive discomfort for the patient.

Ergonomics is a major factor regulating the usability of our device. A large portion of dysphagic patients are geriatric, and a significant number have suffered from a stroke or other medical condition. The final device must be easy to control by a patient with below-normal motor functioning. The device should also require minimal set-up and be simple to operate. The device must not require excessive maintenance or re-application once inserted into the oral cavity and displays must be large enough to be clearly read by patients with poor vision. The device must be around 20 mm in diameter to be small enough to fit comfortably within the mouth, but large enough to not pose a significant choking hazard. The device must be lightweight as the users may be weak or easily fatigued.

### **Testing Apparatus Design Alternatives**

In order to determine the long-term functionality of the air-filled bulb component of the IOPI device, a rigorous testing method was thoroughly planned and enacted. Prior to implementing the chosen test method, three potential test designs were created and evaluated.

#### ***Force Apparatus***

The first test was designed to analyze IOPI pressure readings over time while applying a consistent force to the bulb. This test would determine if pressure readings on the device differed over time when an air-filled bulb was loaded with a consistent, predetermined force. If the device readings showed a decline in magnitude, a decreased responsiveness of the air-filled bulbs would be present. As shown in Figure 3, this test would be conducted using an inverted spring scale (intended for weighing mail) that would be manually pushed downward onto the air-filled bulbs.

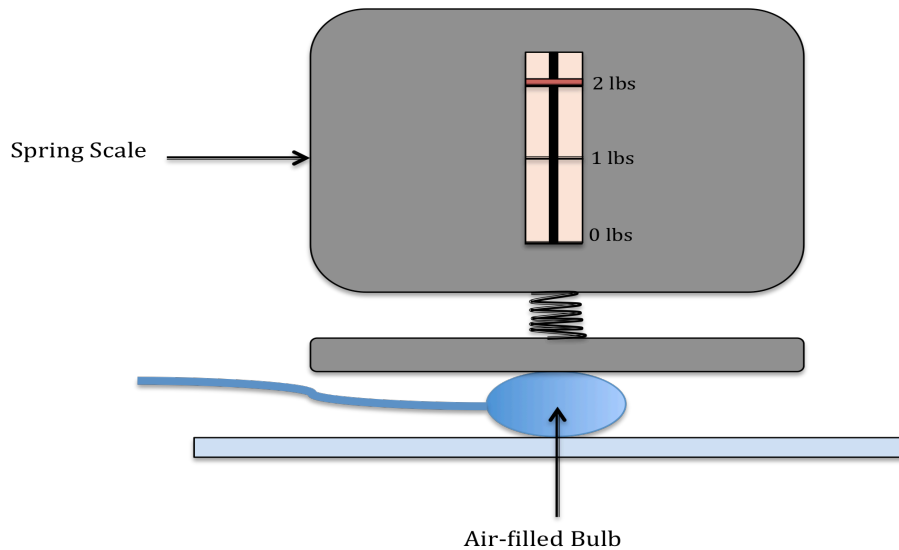

**Figure 3: Force Testing Apparatus.**

The inverted spring scale would be pressed downward on the bulb with 8.9 N of force, and the subsequent pressure reading on the IOPI device would be recorded.

Force would be applied until the scale reached its desired reading of 8.9 N. This value was chosen as the compressive force because it was the highest accurately achievable reading with the spring scale. Also, it

produced a reading that was approximately 50% of the initial lingual maximum values for the two group members who completed the exercise regimen. Testing at 50% of the maximum would prevent bulb deformations that would occur due to many compression repetitions at a near maximum force. Although this method would accurately detect a problem within the electronics or tubing connections, it may not account for small air leakage due to increased permeability or plastic softening over time. In the event of a small air leak or softened plastic, the bulb may be compressed farther by loading a constant 8.9 N force than it would be as a new bulb. Despite this greater compression distance, the applied force would likely result in the same pressure reading on the IOPI as a new bulb. This would be misleading, as the reading would suggest no change in the bulb, when in reality the bulb may be compressing different amounts.

### ***Compression Apparatus***

The second testing method, a consistent compression apparatus, was designed to account for the complication described above. By compressing the bulb to a fixed displacement rather

than with the same amount of force, a leaky or softened bulb would give a lower reading on the IOPI device than a new air-filled bulb. This compression test would be conducted using a device commonly used for clamping and stabilizing wood, as shown in Figure 4. This device has two

rigid plates, one of which is fixed while the other is adjusted by a rotating handle. As the handle is twisted, the adjustable plate slides along two support rails and moves closer to the fixed plate. In testing, an air-filled bulb

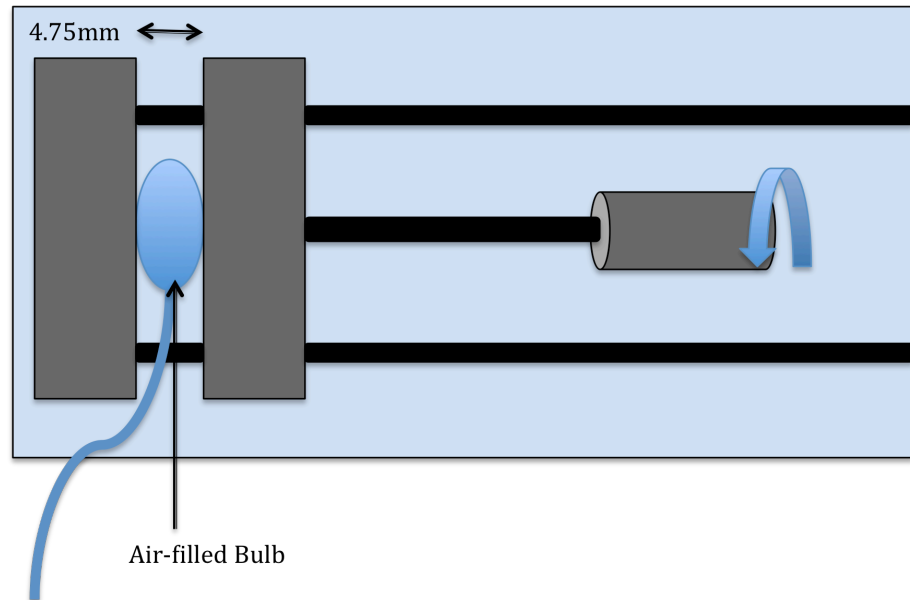

**Figure 4: Compression Testing Apparatus.**

As the knob is twisted, the moveable rigid plate would slide along the parallel track towards the fixed plate, compressing the air-filled bulb. The pressure reading that would result from this compression would then be recorded.

would be placed between the rigid plates, which would then adjusted to a predetermined separation of 4.75 mm. This separation would be sufficiently small to result in visual compression of the bulb. The value of 4.75 mm would used as a predetermined compression distance, as it would be an easily repeatable value and would result in a similar pressure reading as the force test that was previously described. A digital calipers would be used to measure the separation gap between each rigid plate to ensure the same compression distance would be achieved in each trial. Although this test would provide insight into how a consistent compression may change over repeated testing, it would not assess how much force was exerted on the bulb itself.

## ***Instron Electromechanical System***

Instron manufactures a wide assortment of mechanical testing equipment. Its electromechanical systems can be used to perform tensile or compression force testing on materials in a static state<sup>15</sup>. A control panel or operating computer enables programs to be established and run repeatedly on the machine. See Figure 5 for an image of an Instron electromechanical system. For our testing, two flat load cell plates would be interchanged for the



**Figure 5: Image of an Instron Electromechanical System<sup>15</sup>.**

This Instron system has two hydraulic load cell clamps that can be used to pinch a material and then pull on it to determine how much force is required to break it. For our project, we would replace the hydraulic clamps with two flat load cell plates that could then be used to compress the bulbs to a certain extent and measure the force required to do so.

hydraulic load cell clamps shown. A bulb would be secured to the lower plate so that it does not shift during the course of data collection. A program would then be set to lower the upper load cell a specified amount in order to perform a compression test. As the load cells compress the bulb a standard distance, they would measure the force required to accomplish this compression. The computer would then display the peak force measured during the trial. This process could be repeated numerous times to establish an average peak force value with standard deviation. Because the maximal force exerted on the bulbs by patients' tongues is no more than 45 N (10 lbf), this is the maximum force

that we want to achieve during testing. Typical load forces measured by Instron electromechanical machines range from 0.5 kN to 600 kN (112 lbf to 135,000 lbf), meaning that the data obtained from them for our project would be fairly inaccurate<sup>15</sup>.

## **Testing Apparatus Design Matrix**

To determine which tests would be most beneficial in assessing the long-term functionality of the air-filled bulbs, a comparative examination of the three proposed methods was conducted with a design matrix, included in Table 1 below. The design matrix provided a quantitative analysis of which test best evaluated the responsiveness of the IOPI bulbs. The five categories used in the design matrix were precision, cost, scope of testing, imitation of clinical use, and variability for experimental conditions. Based on the point breakdown shown below, the constant force with the spring scale method received the largest allotment of points. Due to its limitation in the scope of testing described below, however, we have chosen to pursue testing with both the consistent force and consistent compression methods.

**Table 1: Testing Apparatus Design Matrix.**

The maximum point values are indicated in parentheses in the row headings. Both the compression and spring scale test methods will be used in proceeding analyses.

	<b><u>Compression</u></b>	<b><u>Force</u></b>	<b><u>Instron</u></b>
<b>Precision (30)</b>	25	30	10
<b>Cost (10)</b>	8	8	2
<b>Scope of Testing (30)</b>	15	15	25
<b>Imitation of Clinical Use (10)</b>	5	8	4
<b>Variability for Experimental Conditions (20)</b>	12	15	10
<b>Total (100)</b>	<b>65</b>	<b>76</b>	<b>51</b>

### ***Precision***

Precision was allotted nearly one third of the 100 points possible, as having a test method that did not produce precise results would be futile. Results and conclusions produced by an imprecise test could potentially be invalid. The first test method, the consistent force test, received a perfect score of 30 points in this category. This high score was based on trial runs using this testing method that produced extremely precise results between successive trials. The second method, consistent compression, had a slightly lower value of 25 points. This test was still sufficiently precise, however it was not as precise as the first testing method in observed trial runs. This largely resulted from human error, as the conduction of the force test was more easily repeatable. The third and final method, the Instron machine, received the lowest value of ten points. This low value is attributed to the limited capabilities of the Instron machines available through the UW-Madison Department of Engineering. The available machines are specialized in heavy, sustained loads and would be largely inaccurate in producing small-order compressions ranging from 8 to 20 N in numerous repetitions<sup>16</sup>.

### ***Cost***

Cost of testing, although less important than precision, was still a limiting factor in selecting a testing method for our air-filled bulbs. The consistent force and compression tests received equivalent allotments of eight out of a possible ten points, as both methods were under \$20 and were therefore considered to be relatively cheap. The Instron machine, however, would have been more expensive. Despite the use of the machine itself being provided by university faculty, purchasing a specialized load cell capable of the task at hand would have been out of our project's budget.



### ***Scope of Testing***

The third category, scope of testing, was extremely pivotal in the final selection of a test method, and as such was allotted 30 possible points. Scope of testing as a category includes the ability to assess both the force applied to the bulb during each test as well as the compression distance achieved in each trial. As described in the testing alternatives, both of these categories may be needed to truly assess any defects that are present in the air-filled bulbs. The consistent force test solely analyzes force, and the consistent compression test only yields compression results. Because each of these first two methods is only capable of one scope of our desired overall analysis, they each received half of the possible points. The Instron machine, however, is highly technical and computer-based, allowing both the compression distance and force to be recorded in each trial. This resulted in the Instron machine receiving 25 points in the scope of testing category. Five points were subtracted from the possible 30 for this method as it is incapable of accurately measuring a constant force on a small scale.

### ***Imitation of Clinical Use***

Although not as important as some of the previously discussed categories, the ability of each test method to mock the clinical use of the bulbs may have a significant affect on interpreting test results. Out of a possible ten allotted points, the consistent force test received the highest rating of eight points in this category. The consistent force method was given this score as it is the only test method that relatively mimics the force loading exerted by the tongue. The exertion of force can be slowly and evenly applied in this method, whereas the other two test options have very rigid mechanical movements that do not represent lingual loading. Secondly, the spring-loaded plate is less rigid than the Instron load cells and the compression apparatus plates. Less rigidity provides a slight yielding that is more representative of the palate of a

human oral cavity. Finally, the Instron machine was assigned a lower value, four points, than the compression apparatus, which was given five points, as its movements are most rapid and mechanical, whereas the compression speed can be more easily controlled.

### ***Variability for Experimental Conditions***

The fifth and final category used to analyze the proposed testing alternatives was the ability to test different experimental conditions. This category entailed the incorporation of different external conditions into the testing apparatuses with ease and accuracy. Variable conditions may largely affect bulb function, and testing these conditions may be essential in accurately determining bulb malfunction. Because of its future importance, this category was allotted 20 total points. As the consistent force method only has a one-plate surface it would be most easily incorporated into variable conditions. As a result, this test received a score of 15 points. Conversely, the compression test has two fixed plates necessary for accurate testing. Varying the external environment would thus require modifying one of the apparatus plates to accommodate this change. Because of this slight modification requirement, the compression method was awarded 12 points. The Instron machine would be the least susceptible to modification for variable external environments, as the highly specialized load cells would be more complicated to adjust. This increased complexity may make testing under different conditions less accurate, and led to a score of 10 points.

### **Exercise Regimen**

To test whether the air-filled bulbs were in fact changing as a result of our clients' exercise protocol, two of our members completed the entire eight-week regimen. We followed the same exercise program that our clients' used in "The Effects of Lingual Exercise in Stroke

Patients with Dysphagia”. First, each participant had baseline peak pressures measured. This consisted of them performing two sets of three attempts to achieve a peak value in both the anterior and posterior bulb positions as shown in Figure 6<sup>5</sup>. As the protocol calls for the individuals to exercise at 60% of their maximums for the first week, these measurements were then multiplied by a value of 0.60. Similarly, the measurements were multiplied by a value of 0.80 to find the exercise pressures for the second week, when the participants exercised at 80% of their maximums. These values were then doubled so that when the bulb was compressed to the proper amount necessary to achieve the exercise value for that week, the central green bulb on the IOPI device would be illuminated. See Figure 1 on page 7 for a picture of an IOPI device and location of the central green bulb in the bulb array.

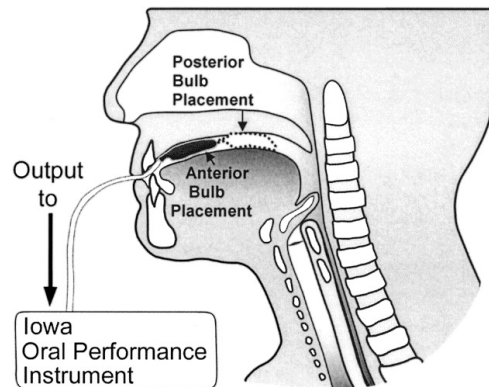

**Figure 6: Positions of Air-Filled Bulb<sup>6</sup>.** During exercise, one set is completed when ten repetitions are achieved in the anterior position, and ten repetitions are achieved in the posterior position.

A week’s worth of exercise consisted of three days of three sets of exercises each day. Each set involved executing ten repetitions in both the anterior and posterior positions by compressing the bulb with the tongue until the central green bulb was illuminated. The individual would continue pressing with the same amount of force for 3 s, and then relax the tongue muscle<sup>5</sup>. Exercises were performed after meals to prevent the potential of improper swallowing leading to choking or aspiration due to fatigued lingual muscles.

Every two weeks, the maximum peak pressures were re-measured. This entailed having the participants perform two sets of attempting to achieve a maximum value three times. The measurements obtained were then multiplied by values of 0.80 and 2, as described earlier, so that

the individuals

could continue to

exercise at 80%

of their new

maximums<sup>5</sup>. The

results from the

eight weeks of

exercise are shown

in Figure 7, and the

calculated percent changes in peak pressures are listed in Table 2. As indicated by the figure and

table, the values increased for both individuals in the anterior position over the eight-week period

and increased for one individual while decreasing for the other in the posterior position. This is

mostly in accordance with what our clients have found in their past studies<sup>5</sup>.

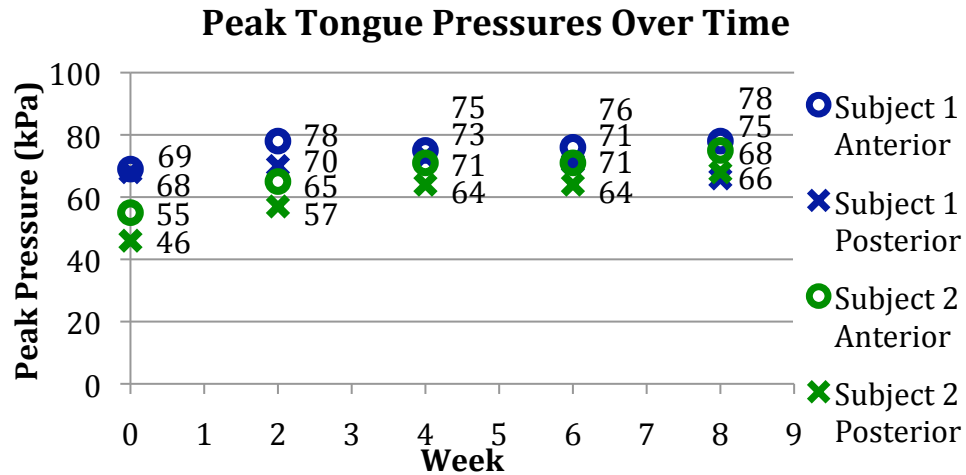

**Figure 7: Change in Peak Tongue Pressure Values After 8 Weeks of Exercise.**  
There is an increasing trend in the measured peak pressure values after 8 weeks of exercise for three of the four conditions.

**Table 2: Percent Change in Peak Pressures**  
After eight weeks of exercise, attainable peak pressures in the anterior position for both subjects demonstrated an increase in value, while the posterior position showed an increase for one individual and a decrease for the other.

	<b>Anterior</b>	<b>Posterior</b>
<b>Subject 1</b>	113%	97%
<b>Subject 2</b>	136%	148%

## Preliminary Testing

### *Compression and Force Testing*

As previously stated, we decided to pursue both the compression and force testing alternatives to obtain the appropriate data necessary to determine if the air-filled bulbs were transforming over the course of the exercise regimen. The resulting pressures obtained by applying a consistent force of 8.9 N and a consistent compression to 4.75 mm can be seen in Figure 8 and Figure 9, respectively.

### Pressure Measurements Dependent on a Consistent Force Applied Over Time

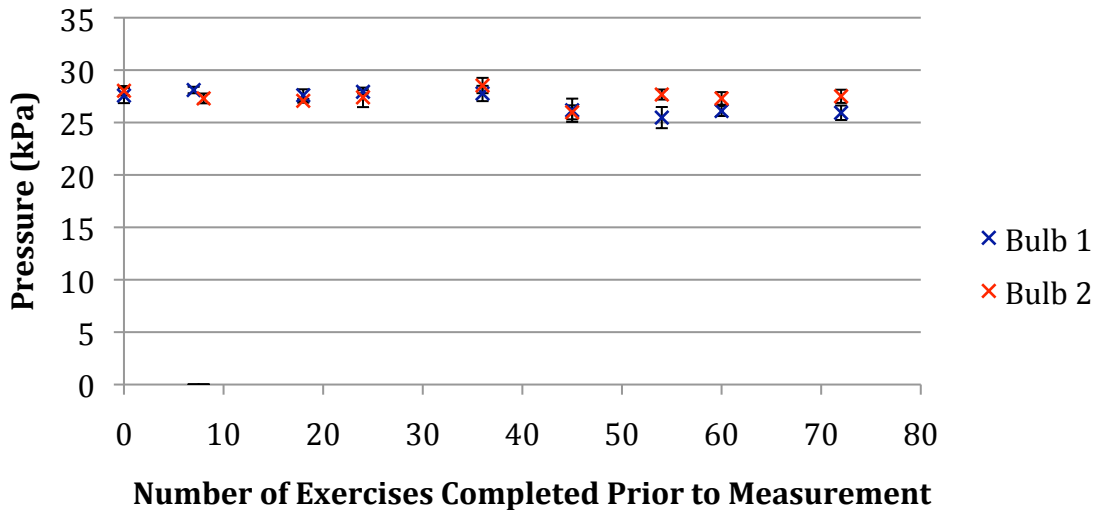

**Figure 8: Pressure Due to a Consistent Force Applied Throughout the Exercise Regimen.** As shown in the plot, the pressure values produced by the application of a consistent force slightly fluctuate over the course of the exercise protocol.

### Pressure Measurements Dependent on a Consistent Compression Applied Over Time

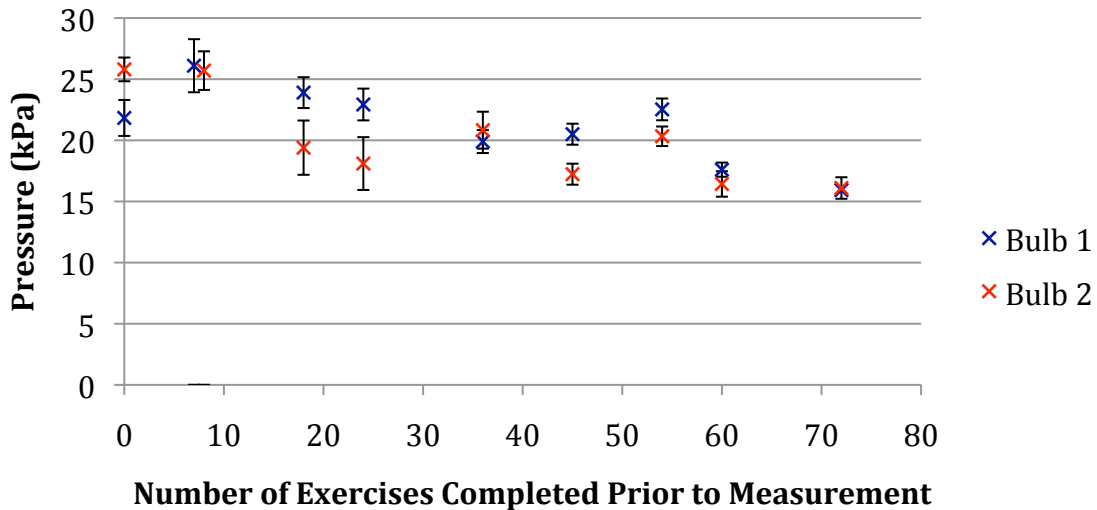

**Figure 9: Pressure Due to a Consistent Compression Applied Throughout the Exercise Regimen.** As shown in the plot, there appears to be a decrease in the pressures produced by the application of a consistent compression, beginning at the data collected after 18 exercises had been completed prior to measurement.

To determine whether or not the pressure values changed over time, a statistical  $t$  test was performed. A  $t$  test evaluates if two separate sample averages are equal to one another, a condition known as the null hypothesis. If the null hypothesis is proven true, then any variation between the two samples can be considered as due to random error. However, if the null hypothesis is not proven true, then the two averages are considered to be different, a condition known as the alternative hypothesis<sup>17</sup>. Values of  $t$  for the average pressures of bulbs were calculated using the following equation:

$$t = \frac{(\bar{y}_1 - \bar{y}_2) - (\mu_1 - \mu_2)}{\sqrt{\frac{s_1^2}{n_1} + \frac{s_2^2}{n_2}}} \quad (1)$$

where  $y_1$  is the average of the first sample (from baseline data),  $y_2$  is the average of the second sample (from data obtained after eight weeks of exercises had been completed),  $\mu_1 - \mu_2 = 0$  because the null hypothesis is that the two sample averages are equal,  $s$  is the standard deviation of the sample, and  $n$  is the number of samples. The number of degrees of freedom in the samples was then calculated using the following equation:

$$df = \frac{(SE_1^2 + SE_2^2)^2}{SE_1^4/(n_1 - 1) + SE_2^4/(n_2 - 1)} \text{ with } SE_y = \frac{s}{\sqrt{n}}. \quad (2)$$

The calculated degrees of freedom were then rounded down to the nearest tens digit to be compared to values obtained from a Student's  $t$  distribution table<sup>17</sup>. The results of applying Equations 1 and 2 to the data collected are shown in Table 3.

**Table 3:  $t$  Test Values for Bulb Pressure Data.**

Equations 1 and 2 were applied to the pressure values obtained from the consistent force and compression tests.  $t_{\text{table}}$  values were obtained from a Student's  $t$  distribution table. The  $t_{\text{table}}$  values listed are for a confidence level of 95%<sup>17</sup>.

	<b>Bulb 1 Force</b>	<b>Bulb 2 Force</b>	<b>Bulb 1 Compression</b>	<b>Bulb 2 Compression</b>
<b><math>t</math></b>	10.04	4.430	14.39	22.24
<b><math>df</math></b>	50	30	30	30
<b><math>t_{\text{table}}</math></b>	2.009	2.042	2.042	2.042

If  $t < t_{\text{table}}$ , then the null hypothesis is true. If  $t > t_{\text{table}}$  then the alternative hypothesis is true<sup>17</sup>. Accordingly, we can be 95% confident that the bulb 1 and bulb 2 force values are not the same before and after the exercise regimen, and therefore the pressure output by having a consistent force applied to the bulbs changes over time. Likewise, at the 95% confidence level the bulb 1 and bulb 2 compression values are not the same before and after exercise, which implies that applying a consistent compression to the bulbs will cause a change in the amount of pressure produced over time. As reflected by the  $t$  values and plots, the changes in pressure due to compression vary much more drastically than those due to force. Potential causes of these declines in pressure over time may be due to failure at the connection points between the bulb, tubing, and IOPI or changes in bulb material properties due to viscoelasticity or water absorption.

After the fifth week of testing, which corresponds to 45 exercises completed, a small error was found in the compression test procedure. Prior to this the bulbs were not being secured in the clamp apparatus while being tested, and therefore they occasionally moved slightly between trials. It was initially believed that the clamp plates had a constant distance between them for their entire areas so the shifting of bulb position would not make a difference, but during the fifth week it was discovered that this was not the case. From this point on, the connection tubing was taped to the stationary plate so the bulbs were always orientated directly in the center of the plate during testing. This correction resulted in improved precision and accuracy of the collected data, as evidenced in Figure 9. The error present in the first five weeks of testing, however, was not sufficient enough to diminish the integrity of the general trend observed in the bulb response.

Other errors that affected the results of these tests were the amount of air in the bulb and tubing at the time of testing, and the length of time that elapsed between the test and the most recent exercise. In order to minimize the effects of air volume, the tubes that attach the bulbs to the IOPI device were temporarily disconnected prior to testing each week to allow for air within the bulb to equilibrate with the atmosphere, at a pressure of 100 kPa. On the weeks when peak pressures were obtained (corresponding to 18, 36, 54, and 72 exercises completed) the testing was performed on Mondays, whereas the rest of the weeks the data were collected on Fridays. This was done so the subjects' lingual muscles could rest and not be fatigued for the peak pressure measurements that were performed immediately following the testing. However, because the bulbs are viscoelastic in nature, this added time allowed the bulbs to recover more from the stresses applied to them during exercise than when the bulbs were tested on the same day as exercising. The result of this error is seen in the values collected on peak pressure weeks being slightly higher than those collected on other weeks, but these values still exhibited the same overall trend.

### ***Water Absorption Testing***

Once it was confirmed that some aspects of the bulbs were changing over time, as reflected by the compression and force test data, the next step was to determine the cause of these changes. The first experiment performed was a water absorption test. This was done because if the bulbs absorb water from the oral cavity during exercising, water can become interspersed within the plastic and thus lower forces between PVC polymer chains. Weakening these intermolecular forces could potentially result in softening of the bulb and increased permeability to air.



The American Society for Testing and Materials (ASTM) creates testing standards that can be used to evaluate materials and compare them to each other based on certain properties. For the water absorption test, we used ASTM Standard D570-98: Standard Test Method for Water Absorption of Plastics. To perform the test, we sealed three bulbs by inserting stoppers into the tubing connections, so the amount of air within the bulbs remained constant throughout the test. The bulbs were then weighed and the tubing was secured to the inside of a container filled with water, so the bulbs were completely immersed in the water. After being submerged for 24 hr at a temperature of  $23 \pm 1$  °C, the bulbs were removed from the water, wiped with a dry cloth to remove water on the surface, and weighed again<sup>18</sup>. The results of this experiment are shown in Table 4.

**Table 4: Results from Water Absorption Test.**

Three separate bulbs were tested to ensure repeatability of the results. None of the bulbs experienced a change in mass during the course of the testing.

	<b>Mass Before (g)</b>	<b>Mass After (g)</b>	<b>Mass Change (g)</b>
<b>Bulb 1</b>	1.94	1.94	0.00
<b>Bulb 2</b>	1.90	1.90	0.00
<b>Bulb 3</b>	1.79	1.79	0.00

As the masses of all three bulbs did not change during the testing, it can be concluded that they did not absorb any water during this time. This is a strong indication that water absorption is not a cause of the changes in bulb properties, because over the course of the exercise regimen the total amount of time a bulb is in a patient’s mouth is approximately 1.5 hr, which is far less than the length of the test.

***Underwater Squeeze Testing***

To further determine the cause of the decline in pressure observed in the exercise tests, an underwater squeeze test was conducted. In this test, the air-filled bulb and tubing were

submerged in water up to the metal input port on the IOPI. The submerged bulb was then manually squeezed while the bulb and tubing connection points were carefully observed for visible bubbling. Bubbling would indicate air permeation through the bulb material or connection points, which would provide evidence that leakage was the cause of failure in the system. For both bulbs tested, pressure application did not result in bubbles forming from the bulbs themselves. In one of the bulbs, however, visible bubbling was observed at the connection between the vinyl tubing and metal input port of the IOPI. This suggested that failure may predominantly occur at points of connection rather than the bulb itself. To further solidify air leakage through the connections as the main cause of pressure decline, a design with improved connection points was conceptualized and fabricated.

### **Tubing Design Alternatives**

The primary focus of design modification was the connection points in the pressure sensing system. As shown in the preliminary testing, the connection points were proven to leak air. There was no direct evidence, however, that the bulb itself was susceptible to air leakage over time. Leakage from connections results either from tube loosening or inadequate sealing. Loosening likely results from bending, twisting, and exposure to pressure from normal use and storage of the device. Loose connections and inadequate sealing in the pressure system would result in air expulsion when pressure is applied to the bulb during exercise. Following exercise, the air may not reenter the system as quickly as it escaped, as no active pressure source forces it back in through the connections. If the next exercise is conducted relatively soon, the entire system would contain less air, causing the bulb to be partially deflated and alter pressure readings. Devising a connection system that is more resilient to everyday use and storage,

resistant to loosening, and completely airtight between the bulb and the IOPI device would greatly improve the bulb responsiveness over time.

Three design alternatives to improve connection points were developed prior to the construction of a design prototype. The first alternative was to extend the existing tube on the bulb so it would directly connect to the IOPI device itself. This would eliminate two connection points between the bulb and pressure sensing electronics, and greatly reduce the susceptibility to failure. The tubing itself would be extended and constructed of the same vinyl as the original bulb tubing.

The second design alternative would have the same number of connections as the current design, but the tube from the bulb to the IOPI device would be constructed from a fluorinated polymer such as Teflon. The connection between the bulb and the Teflon tube would be outfitted with an airtight Teflon connection system, containing Teflon screw connectors and gripper fittings. The connection to the IOPI device would be a tightly fitted Teflon tube that slides onto the metal input port. This slip-on tube connection would be connected to a Teflon luer adapter, which would in turn be connected to the Teflon tubing that connects the bulb and device.

The third design alternative would be identical to the second except for its mode of connection to the metal input port on the IOPI. The third design would call for modification of the IOPI device itself, changing the input port to a Teflon screw connector. The conventional metal port provides an insufficient connection, as the smooth metal surface has a low surface friction for a vinyl or Teflon tubing to adhere to. Replacing the metal port with a Teflon screw connector would allow the Teflon tubing to be screwed to the IOPI device using a Teflon screw housing connector. This would provide a sturdy, airtight connection that would not be susceptible to the bending or loosening that could occur in the first two design alternatives.

## **Tubing Design Matrix**

To determine the most suitable design to construct for our prototype, a comparative analysis was conducted using a design matrix. The design matrix, shown in Table 5, provided a quantitative representation of the strengths and weaknesses associated with each design as well as a distinction of which design best adheres to the desired criteria. As shown by the allotment of points, the Teflon tubing and connectors design was awarded the highest score, and was consequently chosen for construction. It is noteworthy that the Teflon design with IOPI modification was nearly equally successful in all categories except feasibility. If this design option were suitable, it would have been chosen over the similar Teflon design without IOPI modification.

**Table 5: Tubing Design Matrix.**

The maximum point values are indicated in parentheses in the row headings. The Teflon Tubing and Connectors option was selected for prototyped construction.

	<b>Single Connection Vinyl Bulb</b>	<b>Teflon Tubing and Connectors</b>	<b>Teflon with IOPI Modification</b>
<b>Gas Permeability (40)</b>	25	35	35
<b>Cost (10)</b>	10	5	3
<b>Feasibility (20)</b>	10	20	5
<b>Connection Reliability (30)</b>	20	20	30
<b>Total (100)</b>	65	80	73

### ***Gas Permeability***

The first category analyzed was the gas permeability. This category was allotted 40 points because it is extremely important that the designs are not susceptible to air loss through permeation. The single connection bulb design received the least amount of points (25) as it was

composed of vinyl. Vinyl is not naturally as flexible as Teflon and must be softened with a plasticizer. The incorporation of plasticizers into a polymer significantly increases its permeability to gasses. Therefore, the vinyl tubing was allotted a lower point total than both Teflon alternatives. Teflon is naturally flexible and does not require the addition of plasticizer, which is why both of the alternatives that contained it were given 35 points.

### ***Cost***

The second criterion examined was the design cost. As it was less important than proper functioning, cost was allotted a total of 10 points. The vinyl single connector bulb received a perfect 10 points. If manufactured in the same bulk quantities as the current bulb, this design would be less expensive than the current design. The Teflon design with no IOPI modification received 5 points, as it would be composed of slightly more expensive Teflon connectors and gripper fittings. The third design alternative, Teflon connectors with IOPI modification, received 3 points, because it would require alterations to the expensive IOPI device.

### ***Feasibility***

The third category, feasibility, is defined as the ability to incorporate the design modifications into the existing IOPI system. As the clients did not permit alterations to the electronic component of the IOPI, we were limited to bulb and tubing modifications only. As a result, the feasibility of incorporating a Teflon screw connector onto the IOPI device is not available at this time. However, it may be possible in future semesters. The third design, involving IOPI modification, therefore, received 5 out of a possible 20 points. The first alternative, the single connection and tube extension design, would also be slightly problematic, as we are not able to synthesize the bulb ourselves, and outsourcing the dip casting of a single

bulb to a manufacturer would not be ideal. The Teflon tubing and connector design without IOPI modification would be the most feasible, as it could be pieced together manually with the proper materials. Thus, this design received a perfect 20 points.

### ***Connection Reliability***

The final category in the comparison was connection reliability. The single-connection vinyl design and the Teflon connectors without IOPI modification were equally allotted 20 points out of a possible 30. This allotment resulted from the fact that both designs contain a single conventional connection in which a tube is inserted onto the metal input port on the IOPI device. This connection would be susceptible to leakage under sufficient pressure, and the connection would likely fail with time. Despite having more than one connection, the Teflon design's second connection would be composed of airtight Teflon connectors, and should theoretically not allow leakage. The third design, Teflon tubing and connectors with IOPI modification, would eliminate the problematic conventional connection, and therefore received a perfect 30 points.

### **Tubing Prototype Construction**

As previously noted, the design matrix yielded the Teflon connectors without IOPI modification design as the most suitable for this project. To construct this design, the existing PVC bulb was outfitted with a Teflon screw connector and 3.17 mm (0.13 in) Teflon gripper fitting. A Teflon tube with inside diameter of 0.79 mm (0.03 in) was also outfitted with a Teflon screw connector and gripper fitting. The Teflon screw connectors on the Teflon tube and bulb tube were then tightly screwed together via a Teflon screw housing connector. The other end of the Teflon tubing (to be attached to the IOPI device) was outfitted with a similar Teflon

apparatus. This apparatus connected to a Teflon luer adapter complete with a small tube that slid tightly on to the metal input port on the IOPI device (analogous to the conventional connection at this junction).

**Final Design Testing**

***Underwater Clamp Tests***

To assess the reliability of the fabricated Teflon tubing connector design, a clamp test was performed. The clamp test was conducted with the conventional IOPI bulb system, the conventional system with the connections sealed with Vaseline, and the Teflon connector design. The conventional system served as a control, while the conventional design with Vaseline sealing aided in quantifying how much air leakage was occurring. Prior to clamping, dimensional measurements of the bulbs were obtained. Using the same clamp implemented in the

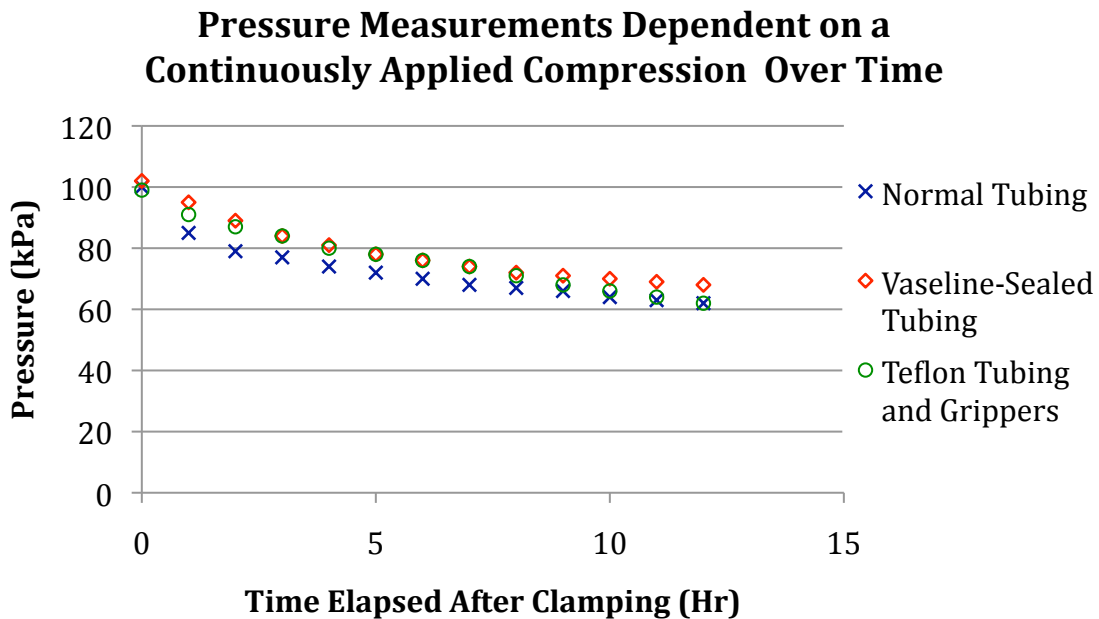

**Figure 10: Pressure Due to a Continual Compression Applied for a Period of Time.** All of the tests demonstrated decays in pressure readings over time. However, when the tubing connections were sealed with Vaseline, the decrease in pressure was slightly less substantial than the other two conditions.

compression testing, the bulb of each design was compressed to a distance of 2.25 mm. The bulb, clamp and as much tubing as possible were then submerged in water that had been pre-boiled to drive off any excess oxygen dissolved in it. Not all of the tubing connections were able to be immersed, because some involve connecting the tubing to the IOPI device itself, which consists of electrical components that would be destroyed if they became wet. Initial pressure readings were taken from the IOPI device followed by repeat readings taken every hour. After the tests were completed the dimensions were measured again. The results are shown in Figure 10 and Table 6.

**Table 6: Dimensional Results from Underwater Clamp Tests.**

Under all three conditions, the length of the bulbs slightly increased while the widths demonstrated a decrease in value.

		<b>Before (mm)</b>	<b>After (mm)</b>	<b>Change (mm)</b>
<b>Normal Tubing</b>	Length	36.68	37.00	+0.32
	Widest Width	10.41	9.47	-0.94
	Narrowest Width	7.35	5.22	-2.13
<b>Vaseline-Sealed Tubing</b>	Length	37.04	38.03	+0.99
	Widest Width	10.43	9.26	-1.17
	Narrowest Width	7.79	5.45	-2.34
<b>Teflon Tubing and Grippers</b>	Length	37.03	37.87	+0.84
	Widest Width	10.62	9.32	-1.30
	Narrowest Width	7.78	4.97	-2.81

As indicated by the plot in Figure 10, all three conditions experienced decays in pressure values over time. Because the Vaseline-sealed tubing maintained slightly higher pressures than the normal tubing, there is evidence that air leaking out from the tubing connections plays a role in this decrease. The fact that this condition still experienced a decrease in pressure values indicates that the viscoelasticity of the PVC bulbs is also a contributor. It is likely that the Vaseline was not able to completely prevent any air from leaking out as it was challenging to apply it to the connections, particularly the one between the tubing and IOPI device. Therefore it



is likely that air leakage plays a more significant role than indicated by these tests. The lack of improved response with the Teflon tubing and grippers can be attributed to two things. First, modifications could not be made to the IOPI device itself, as they would prevent it from being able to be used in exercise regimens for patients after the completion of this project. Therefore the direct connection between the tubing and IOPI remained the same as in the current device. Second, the bulb was not altered in any way, so its viscoelastic effects remained the same.

### ***Simulated Exercise Test***

To determine the effects of air leakage and bulb viscoelasticity that result from the exercise regimen, a simulated exercise test was performed. This consisted of manually squeezing the bulbs to a pressure of 50 kPa, holding for 3 s, and then releasing. Pressure readings were obtained after every 180 squeezes, as this simulated the amount of times the bulbs would be compressed by the tongue during one week of exercise. To obtain the pressure readings, the bulbs were compressed in the clamp apparatus with a gap of 3.50 mm between the plates and the resulting pressure readouts on the IOPI were recorded. The two conditions tested were the normal tubing and the Teflon tubing. The results can be seen in Figure 11.

Both of the conditions demonstrated a decrease in value from the baseline measurements and then fluctuated around 7 kPa lower than this initial value. Overall the pressure readings for the Teflon tubing were higher than those for the currently-used tubing, but because they started this way the cause is likely differences in the bulbs used instead of the tubing itself. We attribute the initial decrease mainly to air leakage because originally enough pressure would have been generated by the simulated exercises to force air out between the connections. As the volume of air within the bulb and tubing decreased as a result, the pressure produced during the simulations

was no longer enough to cause as much leakage. Therefore the variations exhibited after this time are mostly attributable to the viscoelastic properties of the bulbs.

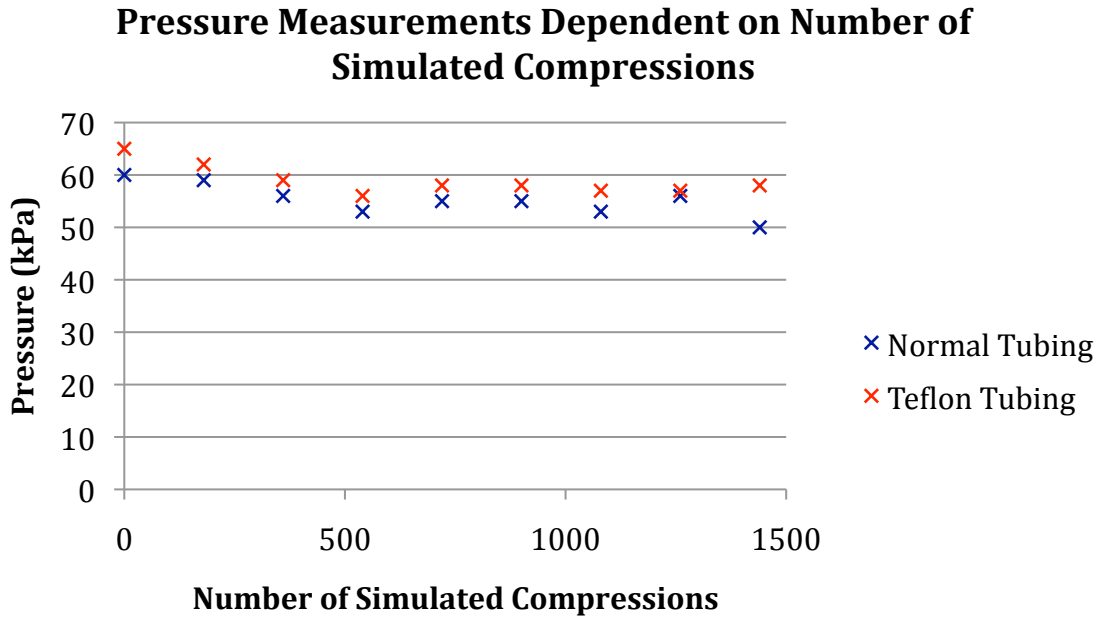

**Figure 11: Pressure Due to a Simulated Exercise Protocol.**

Both conditions experienced an initial decrease in pressure value to approximately 7 kPa lower than their original values. They then fluctuated around these values.

**Time Management**

The majority of our time on this project was devoted to testing the IOPI device in order to determine the existence and causes of any flaws. A complete summary of our activities can be found in Table 7. Early in the semester, our team spent most of our time comparing and contrasting testing methods and researching the IOPI device itself. Becoming familiar with the device was critical in identifying problems later in the semester. After we settled on a combination of two testing methods, we began two clinical trials of the eight-week exercise regimen used by our clients’ patients. During every week of these trials, compression and force testing data were collected and every two weeks the peak values were re-measured. Towards the

end of this time we also began conducting tests to determine the cause of the changes in pressure values that we were observing. With air leakage and viscoelasticity identified as sources of property variation, we implemented a Teflon tubing system to reduce leakage and researched materials that were more resistant to change than PVC and could thus be used to replace it in the bulbs.

**Table 7: Summary of Project Timeline.**

As evidenced by the table, testing the IOPI device was a major objective for our project and accordingly a significant portion of our time was dedicated to it.

Tasks	September				October					November				December	
	3	10	17	24	1	8	15	22	29	5	12	19	26	3	10
<b>Meetings</b>															
Advisor															
Client															
Team															
<b>Product Development</b>															
Research															
Brainstorming															
Design Matrix															
Design Prototype															
Fabricate Prototype															
Exercise Regimen															
Testing															
<b>Deliverables</b>															
Progress Reports															
PDS															
Mid Semester PPT															
Mid Semester Report															
Final Report															
Final Poster															
<b>Website Updates</b>															

**Costs**

The testing of the IOPI and the development of device improvements has been virtually expense free throughout this semester. Many generous donations have allowed our team to keep these costs to a minimum. Our clients, Dr. JoAnne Robbins and Ms. Jacqueline Hind, provided two IOPI devices along with connecting tubes and eight air-filled bulbs to conduct all of the necessary testing. These materials alone cost almost \$2,000, and would have been well out of our

budget range. The clamp used for many of our tests cost \$13.99, but the remainder of the instruments and apparatuses used were loaned to us. The Teflon tubing and luer-lock connection system that we created would have cost around \$35 to make with an attached bulb, but these materials were provided for us by the Pearce Lab in the UW-Madison Department of Anesthesiology.

### **Future Work**

Throughout the course of this semester we successfully determined that the bulbs display a decreased responsiveness over time. This decreased functionality is problematic in practice as the bulbs may require further compression to achieve target forces, or the force readouts may be lower than the forces applied. This is disheartening to patients and can disrupt the therapy process. We have also synthesized a prototype that has improved the connections points of the device, however has not fully eliminated the decreased responsiveness of the bulbs.

Although we determined that the air-filled bulbs are changing over time, further testing must be performed to determine the primary source of air leakage and better characterize the viscoelastic properties of the bulbs. Having a more in depth understanding of these properties would allow us to provide more targeted recommendations to our clients that they could then utilize when developing a device to replace the IOPI. Additionally, as the actual chemical composition of the bulb is still unknown due to numerous attempts at communication being ignored by the manufacturer, any future work that could better characterize bulb properties such as reactions to temperature changes, pH changes, or permeability to air would be useful in bulb analysis.

In order to minimize air leakage from the various tubing connections, we replaced several pieces of vinyl tubing with Teflon tubing. During testing the most significant source of leaking

air from the tubing was observed to be at the connection between the tubing and the IOPI device. If a Teflon luer adapter with one threaded end could be permanently attached to the IOPI device as described in design alternatives section, this connection would become airtight as well. Another solution could be attaching the Teflon tubing to the current IOPI device using Teflon PTFE Heat-Shrink tubing; however, care must be taken as PTFE tubing requires a temperature of 340 °C to shrink correctly and the IOPI device could potentially be damaged during this attachment<sup>19</sup>. If the clients choose to replace the vinyl tubing with Teflon tubing, they can select commercially available, medical-grade biocompatible Teflon tubing to ensure approval from the Food and Drug Administration (FDA)<sup>20</sup>.

As the air-filled bulbs have been shown to have viscoelastic properties, in the future a new bulb could be designed, fabricated, and tested. Possible alternate materials include silicone rubber and nitrile rubber, both of which could be dip cast into new bulbs<sup>21</sup>. Silicone and nitrile rubber both provide greater natural flexibility and resilience than the current PVC with plasticizer bulbs<sup>22,23</sup>. FDA-approved versions of these rubbers already exist and are commonly used in medical devices<sup>24,25</sup>. However, our clients are currently developing a device to replace the IOPI and believe a new bulb for the IOPI would not be useful in the long term. Constructing the bulbs would require contracting an outside company to dip cast a bulb in silicone or nitrile rubber, and could be prohibitively expensive unless requested in bulk amounts.

If bulb material modification is unsuccessful, exploring other pressure sensing systems may result in a viable alternative to air-filled bulbs. Among possible replacements, the most attractive method discovered would be a pliance mat sensor. These sensors, made by Novel, record and display the pressure distribution imparted on the mat in a digital readout. Each mat consists of a matrix of capacitive transducers that are calibrated to operate under desired pressure

ranges. Incorporating a mat sensor into a mouthpiece for lingual sensing would be an attractive alternative to the current system as it would yield a full distribution of lingual pressure, rather than pressure exerted on a single bulb<sup>26</sup>. The main disadvantage of an alternative sensing system such as this is that it does not give the physical feedback that pressing on an air-filled bulb provides. In speaking with our clients, this physical feedback is beneficial to the patients during exercise.

Once our clients have finished developing a device to replace the IOPI, the new device could be evaluated with the same protocol used to evaluate the IOPI. The same constant compression and constant force tests could be performed and the results compared to IOPI air-filled bulb values to determine if the new device loses accuracy over a period of eight weeks. This comparison could be used to determine if the new device measures pressure more accurately over the time period of the exercise regimen. If it is found to accurately measure pressure, it can be considered a good replacement for the IOPI in the clients' exercise program.

## **References**

1. *Department of Medicine: Faculty and Staff*. (2010). Retrieved 10/12, 2010, from <http://www2.medicine.wisc.edu/home/swallowing/faculty>.
2. *Department of Medicine: JoAnne Robbins*. (2010). Retrieved 10/12, 2010, from <http://www2.medicine.wisc.edu/home/people>.
3. Robbins, J. P., Gangnon, R. E. P., Theis, S. M. M., Kays, S. A., Hewitt, A. L. M., & Hind, J. A. M. (2005). The effects of lingual exercise on swallowing in older adults. *J Am Geriatr Soc*, 53(9).
4. Dysphagia. (2010). Retrieved 10/10, 2010, from <http://www.nidcd.nih.gov.ezproxy.library.wisc.edu/health/voice/>.
5. Robbins, J., Kays, S. A., Gangnon, R. E., Hind, J. A., Hewitt, A. L., Gentry, L. R., et al. (2007). The effects of lingual exercise in stroke patients with dysphagia. *Arch Phys Med Rehabil*, 88(2), 150-158.
6. IOPI Northwest. (2010). *IOPI medical*. Retrieved 10/5, 2010, from <http://www.iopi.info/>.
7. *PVC*. (2010). Retrieved 10/17, 2010, from <http://www.pvc.org/>.
8. *Polyvinyl chloride (PVC)*. (2009). Retrieved 10/17, 2010, from <http://www.lenntech.com/polyvinyl-chloride-pvc.htm>.
9. Blass, C. R. (2001). *The role of poly(vinyl chloride) in healthcare* (pp. 34) Rapra Technology Limited.
10. *Precision dip molding & plastic coating*. (2009). Retrieved 10/17, 2010, from <http://www.piper-plastics.com/>.
11. Hewitt, A., Hind, J., Kays, S., Nicosia, M., Doyle, J., Tompkins, W., Gangnon, R., & Robbins, J. (2008). Standardized instrument for lingual pressure management. *Dysphagia*, 23(1), 16-25.
12. Robbins, J., Hind, J. A., & Hewitt, A. L. (2008). *Oral-lever resistance exercise device*. US Patent 7,438,667.
13. *Enhancing the quality of life*. (2008). Retrieved 10/17, 2010, from [http://www.dysphagiaonline.com/en/pages/03\\_what\\_are\\_the\\_signs\\_and\\_symptoms.aspx](http://www.dysphagiaonline.com/en/pages/03_what_are_the_signs_and_symptoms.aspx).
14. Nicosia, M., Roecker, E., Carnes, M., Doyle, J., Dengel, G., & Robbins, J. (2000). Age effects on the temporal evolution of isometric and swallowing pressure. *J Gerontol A Biol Sci Med Sci*, 55(11).
15. *Instron: The difference is measurable*. (2010). Retrieved 10/15, 2010, from [http://www.instron.us/wa/home/default\\_en.aspx](http://www.instron.us/wa/home/default_en.aspx).
16. Lang, B. (9-20-2010). Instron machine: Personal interview.
17. Samuels, M. L., & Witmer, J. A. (2003). In Yagan S. (Ed.), *Statistics for the Life Sciences* (3rd ed.). Upper Saddle River, New Jersey: Pearson Education, Inc.
18. American Society for Testing and Materials International. (2006). *ASTM Book of Standards 2006: Section 8, Plastics* (28th ed.). Philadelphia, PA.
19. *Teflon Heat Shrink*. (2010). Retrieved 12/02, 2010, from

<http://www.zeusinc.com/extrusionservices/products/heatshrinkabletubing/teflonheatshrink.aspx>.

20. *Design & manufacture fluoroplastic tubing and heat shrink*. (2010). Retrieved 12/02, 2010, from <http://www.texloc.com/index.html>.
21. *Dip casting*. (2010). Retrieved 12/02, 2010, from [http://www.ssp-simatrix.com/About\\_Us/Dip\\_Casting](http://www.ssp-simatrix.com/About_Us/Dip_Casting).
22. *About silicone rubber*. (2010). Retrieved 12/02, 2010, from <http://www.dowcorning.com/content/rubber/silicone-rubber.aspx>.
23. *Rubber material selection guide*. (2005). Retrieved 12/02, 2019, from <http://www.robinsonrubber.com/pdfs/NitrileRubber.pdf>.
24. *FDA approved silicone rubber*. (2010). Retrieved 12/02, 2010, from [http://www.rubbersheetroll.com/silicone\\_fda\\_approved.html](http://www.rubbersheetroll.com/silicone_fda_approved.html).
25. *Medical device component manufacturing*. (2010). Retrieved 12/02, 2010, from <http://www.daprorubber.com/medical-device-component-manufacturer.aspx>.
26. *State of the art technology for pressure distribution measurement*. Retrieved 12/03, 2010, from <http://novel.de/novelcontent/pliance/hand>.



## Appendix

### **Project Design Specifications**

December 8, 2010

**Group Members:** Sarah Reichert, John Byce, Katherine Lake, Chris Besaw

**Advisor:** Professor John Webster

#### **Function:**

Dysphagia, or difficulty swallowing, is a symptom that is experienced by up to 76% of stroke patients and 22% of people 55 years and older. Without treatment, pneumonia, malnutrition, dehydration and airway obstruction can result in patients having higher rates of morbidity and mortality. The Iowa Oral Performance Instrument (IOPI) is a device that has been used in exercises that progressively strengthen the tongue, but it has been reported to have a decreased responsiveness over time. We aspire to determine whether the IOPI bulb undergoes alterations after repeated use and if so, what the cause of these changes are. We will then seek to modify the design of the bulb in order to alleviate these problems.

#### **Client Requirements:**

- Alterations should prevent IPOI bulb from changing in elasticity during 8 weeks of use.
- Must be harmless to the tongue, palate, and other interior surfaces of the mouth.
- Must hold up to the standards and regulations of the Food and Drug Administration.

#### **1. Physical and Operational Characteristics**

**Performance requirements:** This product will need to deliver accurate and consistent results for the entire 8-week duration of the exercise regimen.

**Safety:** The product cannot be harmful to the mouth, tongue, or throat, as it will be placed between the palate and tongue during exercise.

**Accuracy and Reliability:** Consistent readings from the device are essential, so that the patient can continue exercising in accordance with the program. The bulb must be designed so that there is no pressure loss or material degradation over time.

**Life in Service:** The bulb must be usable 60 times a day, 3 days a week, for the 8-week length of the exercise regimen. This amounts to 1,440 uses at 37 °C.

**Shelf Life:** The product should be capable of being stored at standard room temperature and pressure for an extended time period. Without compression of the plastic or disruptions from the environment (i.e. extreme heat: >30 °C, extreme cold: <5 °C, or significant humidity >75%) the product's functionality is not expected to decline.

**Operating Environment:** The product design must be made to function in the oral cavity of a human patient. A typical oral cavity contains extensive amounts of human saliva, which must not interfere with proper function of the device. The normal temperature of the oral cavity is 37 °C.

**Ergonomics:** As a great majority of patients suffering from dysphagia are geriatric and a significant portion have suffered from a stroke or other medical condition, ergonomics is extremely important. The final product must be easy to control by a patient with below-normal motor functioning. The product must also have minimal set-up and be easy to operate. The device must not require excessive maintenance or re-application once it is inserted into the mouth, and it must have displays that are large enough to be clearly read by patients with considerably poor vision.

**Size:** The product must be small enough to fit inside the oral cavity of users. Current products on the market are approximately 20 mm, as this size reduces choking hazards while still being small enough to easily operate.

**Weight:** The product should be as lightweight as possible without impeding functionality or usability, as the user may be weak or easily fatigued. A heavy product may cause physical strain or discomfort to the user.

**Materials:** All of the materials used in this project must be compliant with the standards of the Food and Drug Administration, as this device is designed for use on human subjects. The materials must also be resilient enough to withstand eight weeks of use without changing properties in any way.

**Aesthetics, Appearance, and Finish:** The product should be simple to use. Print on the product should be readable to users with vision problems.

## 2. Production Characteristics

**Quantity:** One air-filled bulb will be used for a maximum of eight weeks of exercising.

**Target Product Cost:** Current air-filled bulbs are available from \$3.50 to \$4.00 each, so modified bulbs should be similar in price.

## 3. Miscellaneous

**Standards and Specifications:** The final product will require the approval of the Food and Drug Administration. If the current plastic (polyvinyl chloride, PVC) is used it is already approved for this application.

**Customer:** The intended customer is likely to be a stroke or geriatric patient, and will therefore desire a product that is relatively simple to use, comfortable, can effectively improve their ability to swallow, and is reasonably priced. All of these factors must be considered when altering the design of the current device.

**Patient-related Concerns:** In order to become available to patients for therapeutic use, our changes to the device must be in compliance with all restrictions enforced by the Food and Drug Administration. It must not be harmful to its user in any way. The final product must also be ergonomic to allow use by unqualified patients.

**Competition:** Once it is fully developed, our design could potentially become a competitor to the current bulbs used with the IOPI device. These bulbs are used to measure tongue strength and fatigability via tongue squeezing. They are sold in sealed packages and can be sterilized with cold gas as they are clean but not sterile upon delivery. They cost between \$3.50 and \$4.00 a piece and are recommended for single use only.