

# **Design and Construction of a Quad Rat Vitals Monitor**

December 8, 2010

## Team Members:

Matthew Bollom – Team Leader

Kenneth O. Xu – Communicator

John Renfrew – Primary BSAC

Jay Johnson – Secondary BSAC

Gabriel Bautista – BWIG

## Client:

Alex Converse, Ph.D.

## Advisor:

Amit Nimukar, PhD

## Abstract

The design and construction of a rat vitals monitoring system is essential for simultaneously monitoring multiple anesthetized rats. Our client currently runs PET scans on four rats simultaneously, and the scans can last up to two hours. During the two hour scans, the rats are under anesthesia and doses of the anesthesia medications must be adjusted based on the rats' vitals. The client desires to have an accurate, reliable, and easy to use rat vital monitoring device to aid in this process. The current design for this monitoring device includes force-sensing resistors (FSR) for monitoring breathing rate, thermistors to monitor rectal temperatures, and pulse oximeters to monitor SpO<sub>2</sub> levels and heart rates. The design also includes an easy-to-read graphical user interface (GUI) that displays live traces of the vitals as well as the current value of those vitals in the form of heart rate, blood oxygen saturation, temperature, and breathing rate.

## Table of Contents

<b>Abstract .....</b>	<b>2</b>
<b>Introduction .....</b>	<b>4</b>
<b>Background.....</b>	<b>4</b>
<b>Existing Devices.....</b>	<b>4</b>
<b>Client Requirements .....</b>	<b>5</b>
<b>Motivation.....</b>	<b>5</b>
<b>Previous Semesters' Work.....</b>	<b>6</b>
<b>Final Design.....</b>	<b>8</b>
<b>Testing.....</b>	<b>10</b>
<b>Ergonomics.....</b>	<b>10</b>
<b>Ethical Considerations .....</b>	<b>11</b>
<b>Cost Analysis .....</b>	<b>12</b>
<b>Vision for the Project .....</b>	<b>13</b>
<b>Conclusion .....</b>	<b>14</b>
<b>Appendix.....</b>	<b>16</b>

## Introduction

### Background

The design team's client currently runs positron emission tomography (PET) scans on rats to monitor the location of positron-emitting radionuclides (tracers) within the rats' brains. These scans can last up to two hours, and during the scans the rats are under anesthesia (Figure 1). The client and his assistant must monitor the vitals of the rats during these scans to ensure that they endure no harm while under anesthesia. Currently, the client monitors the rats qualitatively. The skin color of the rats is observed and recorded to ensure that the rats are receiving enough oxygen. The rats' breathing rates are monitored simply by observation, and body temperature is monitored by touch and inexpensive thermometers from Walgreens. Currently, heart rate and blood oxygen saturation are not reliability monitored. The client would like to be able to obtain quantitative measurements of multiple vitals of each rat during the PET scans.



Figure 1: This picture shows four rats in the PET scanner at the client's laboratory. The rats are oriented in a two by two square [1].

Since the PET scanner is designed for monkeys instead of rats, it is large enough to simultaneously scan up to four rats at a time. The client always scans four rats at a time to keep costs down. The radiotracers used in the rats are expensive to produce and decay relatively quickly, so producing a single set of radiotracers for four rats is more cost effective than producing four separate sets for four rats. Due to these restrictions, the vital monitoring device must be able to monitor four rats simultaneously. While under anesthesia, the rats are wrapped in bubble wrap to keep them warm, because the PET scanner is located in a cold room.

### Existing Devices

There is currently one device on the market that is capable of measuring the desired vitals of rats and mice (not including temperature). This is a pulse oximeter designed specifically for rats and mice, called MouseOx, produced by Starr Life Sciences (Figure 2). This device is not capable of monitoring four rats simultaneously, and is priced at \$7000 for one device [2]. This is not what the client is looking for because of the high cost and the inability of the device to monitor

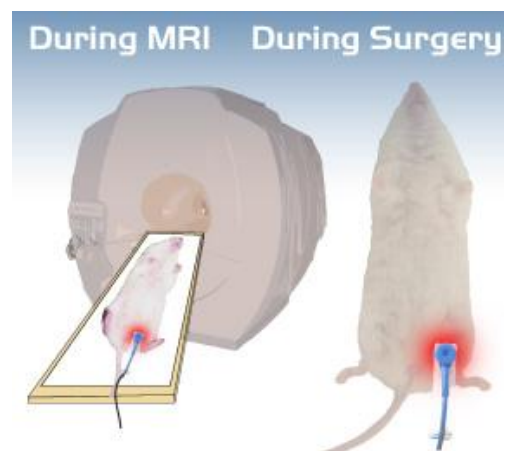

Figure 2: Pulse oximeter produced by Starr Life Sciences capable of measuring heart rate, breathing rate, and SpO2 levels [2].

multiple rats. A different pulse oximeter, produced by Nellcor (the Nellcor N-100), was tested for blood oxygen saturation (SpO<sub>2</sub>) level accuracy when attached to a rat's tail. When SpO<sub>2</sub> levels were between 75% and 95%, this particular pulse oximeter was capable of measuring SpO<sub>2</sub> levels relatively accurately. When compared to the blood sample analysis, the N-100 measured SpO<sub>2</sub> levels with a standard deviation of  $\pm 5.7\%$  [3].

The client occasionally uses a pulse oximeter designed for small animals, specifically monkeys and dogs, but is unable to consistently obtain accurate data because of the high heart rate and low blood volume of rats. The heart rates of these rats can rise above 300 beats per minute, and this pulse oximeter was not designed with a high enough sampling frequency to measure these pulses or the corresponding oxygen saturation. Therefore, the monitoring device must be able to measure vitals outside the normal ranges of small animals or humans.

## Client Requirements

The vitals monitor must be able to simultaneously monitor SpO<sub>2</sub> levels, heart rates, respiratory rates, and rectal temperatures of four rats simultaneously. SpO<sub>2</sub> levels must be monitored with an accuracy of  $\pm 2\%$ . Heart rates of up to 500 beats per minute and respiratory rates of up to 30 breaths per minute must also be monitored. Rectal temperatures of 33 to 38 degrees Celsius (93 – 100 degrees Fahrenheit) are to be monitored as well. All four vitals of all four rats must be simultaneously displayed in a user-friendly graphical user interface (GUI) on one screen. All probes used to monitor rat vitals must be non-invasive and cause no harm to the rats. Finally, no component of the device can pass the cranial end of the sternum, because the PET scans are focused around the cranial region of the rats.

## Motivation

Throughout the duration of the client's experiments, the rats are under heavy doses of anesthesia, which require manual adjustments by the laboratory assistants. The development of a system that readily displays the current values of each vital sign along with the option to view the history of each vital would be extremely beneficial. The laboratory assistants must be informed in a timely manner if any of the four vital signs enter critical ranges, in order that proper adjustments to the anesthesia can be made.

Currently there is no accurate, cost-effective method to monitor and display all four vital signs simultaneously. Since his research is based off of a four-rat setup, the existing devices previously mentioned will not suffice. It would be impractical for him to purchase four of the existing devices that are priced at or above \$7000. The total budget of \$4000 should therefore be considered throughout the design process and while planning to manufacture four final prototypes. Furthermore, the GUI that is to display the four vital traces must be specifically engineered according to the type of data it will be receiving from the circuit elements and corresponding probes designed to monitor each vital sign. The design team's goal is to design an inexpensive, easily operable prototype that incorporates circuit based monitoring systems along with a Java GUI to display the signals received from each monitoring system.

## Previous Semesters' Work

To date, most of the hardware for the project had been designed. A previous team had designed circuits and sensors for monitoring breathing rate and temperature. A force sensing resistor (Figure 3) was used to monitor breathing rate while thermistors (Figure 4) were used measure rectal temperature. These sensors and circuits were extensively tested and shown to meet the client's requirements.



Figure 4: Force sensing resistor



Figure 5: Thermistor

A LabVIEW virtual instrument was designed to create a user interface as well as acquire data and perform signal processing. This interface, shown in Figure 6, included features the client requested such as data auto-saving, history graphs of the vitals, and the ability to mark the data files with points of interest for correlation after the experiment. When this interface was designed, only the hardware and signal processing for breathing rate and temperature was complete. The hardware was scaled for four rats, and this interface was extensively tested.

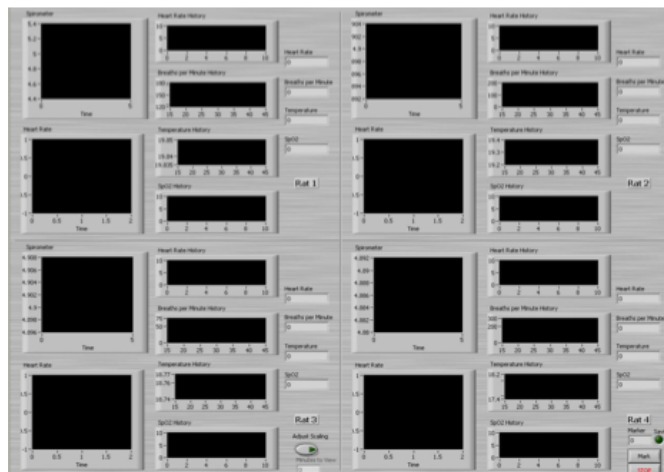

Figure 6: LabVIEW graphical user interface

A previous team also worked with a graduate student to design a pulse oximeter. That team also designed individual pulse oximeter probes (Figure 6), but the results were

never satisfactory because of the need to greater isolate ambient light from interfering with the signals of interest (red and ambient absorbance) and the lack of shielding these probes provided. This team ran out of time to do further testing and suggested utilizing the existing probes for the small animal pulse oximeter the client already had.



Figure 6: Pulse oximeter probe [4]

Once a prototype of the pulse oximeter was complete and tested, a printed circuit board was designed that included circuitry for the pulse oximeter, breathing monitor, and temperature. The circuit boards were then printed, assembled, and programmed. The data was transmitted via USB in a set series of states prefixed by the signal letter (RAIFRAIT... where R is the red signal, A is the ambient signal, etc). A description and block diagram of state control is given on page 15 in Bollom, et al.

This team also proved that the pulse oximeter hardware worked for rats. The hardware was essentially the same for human, with a few resistor and capacitor values modified to account for the lower signal amplitude present in rats. However, since the only probes that were available were the ones that were designed by the team, the team cautioned against making further conclusions until a better probe was obtained and tested.

During the course of this testing, it was observed that LabVIEW was having trouble keeping up with the high sample rate. Instead of acquiring a smooth signal, LabVIEW would drop a point occasionally and cause the display to be useless for several minutes (the graphs auto-scaled). Additionally, this point dropping would increase as sample acquisition time increased. It was apparent that an alternate solution for the user interface would be needed.

Finally, because of the layout of the client's laboratory (see Figure 1), it was suggested to implement wireless data transmission. While the system would function fine with wired connections, the wires along the floor would increase the tripping hazard and USB cables over a length of 15 feet would be expensive. A proof of concept using Wi-Fi was developed for one pulse oximeter board using a standalone laptop as the wireless server and a LabVIEW virtual instrument for data acquisition and signal processing. The team noted there were a few latency issues but they suspected that further software and hardware development would help minimize the time delay.

For more information on the previous work on this project, please see Ho, J. et al., Bjerregaard, R. et al., and Bollom, M. et al.

## Final Design

A little background on the team will help the reader understand the team's progress at the end of the semester. The team spent the first half of the semester working on another project to develop wireless modules for commercially available pulse oximeters. After mid-semester materials had been concluded, it was determined that the project was nearly impossible given the requirements of the client. The team decided to switch to this project because it had components similar to the previous project: it dealt with pulse oximetry and there was a wireless component in the project.

Because of the late switch into the project, the team has no supporting mid-semester material. Nonetheless, the team made great strides towards completing the final prototype. Four circuit boards are completed, and each was tested for operability. Based on the recommendation of a previous team, entirely new user software was developed using Oracle's Java (previously owned and developed by Sun Microsystems), an open-source, object-oriented programming language. A new probe was obtained from the client, and this probe was tested extensively with the Java interface.

The Java interface is shown in Figure 7. This interface will be quadrupled in the final iteration of the project, allowing it to display the vitals of all four rats. It bears a strong resemblance to the LabVIEW interface shown above (Figure 6). The interface consists of 10 second traces of the pulse oximeter output, FSR, and Temperature. An average heart rate,  $SpO_2$ , temperature, and breathing rate are taken over a 10 second period and displayed in text. The interface and its background logic run efficiently and cause no slow-down of the computer in use. Additionally, the interface offers third party manipulation of the graphs being displayed, allows graph processing and manipulation to be done on the fly by the client.

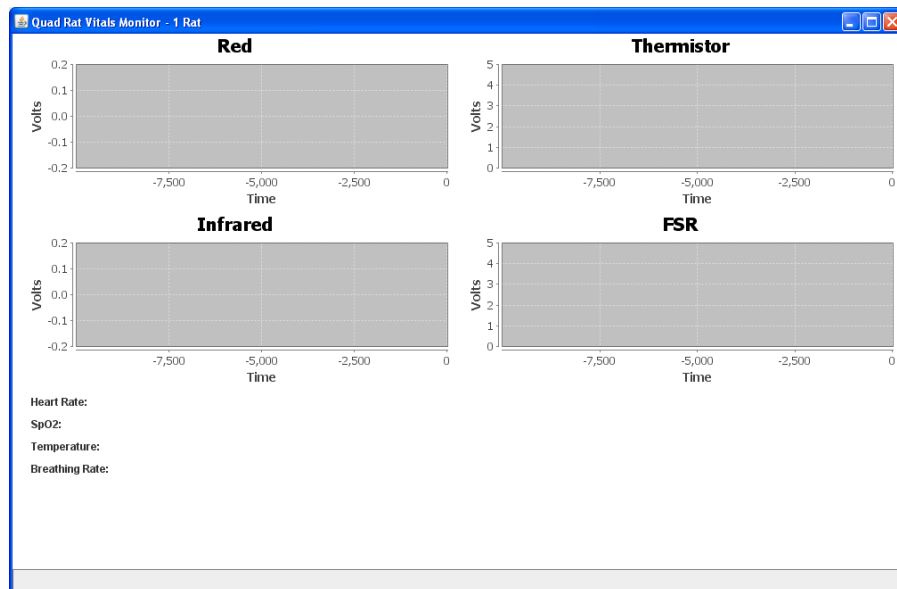

Figure 7: An example of the Java user interface for 1 rat



Extensive filtering and signal processing were also implemented. The signal from the pulse oximeter required the most attention. From the pulse oximeter portion of the board, the  $SP_{O_2}$  and heart rate of the rat must be derived. These are arguably the two most important vitals of the rat during testing. The filtering was conducted both on the hardware itself, as well as in the java program. The interface displays the complete filtered signal for the client. The signal processing is made rudimentary when analyzing a well-filtered signal. The processing detects both the times and the values of the peaks and troughs of the pulse oximeter's probe signal. A similar peak detector was applied to the FSR output to determine breathing rate.

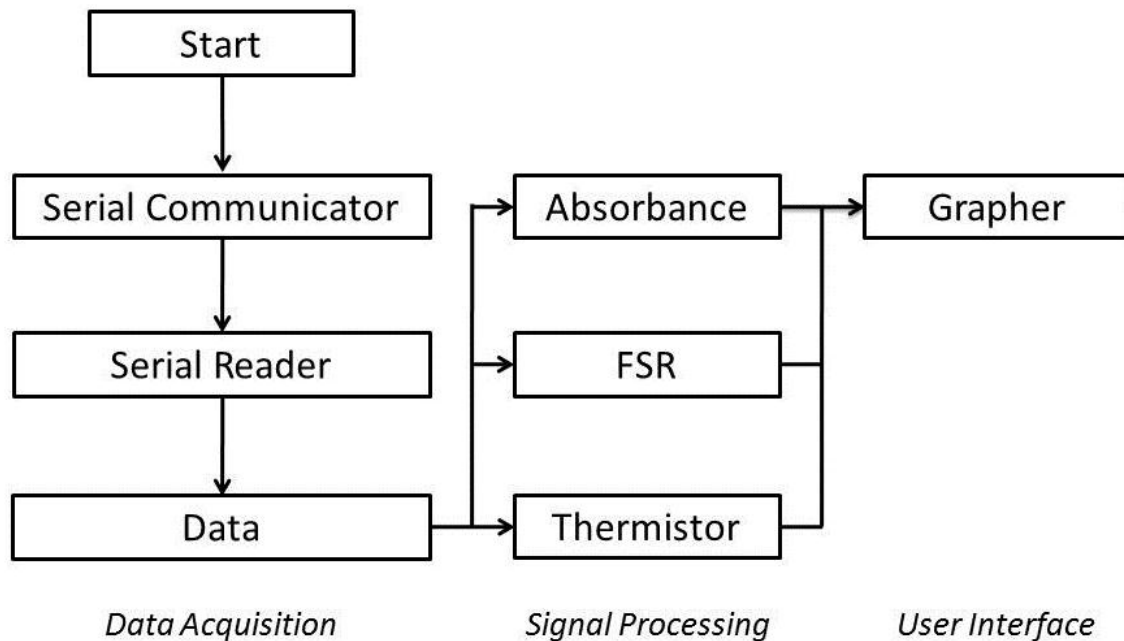

Figure 8: An architectural diagram of the Java program.

The program architecture shown in Figure 8 allows data to be simultaneously acquired and processed. After the serial device has been detected and configured, the data is continuously collected and made available to the signal processing methods. Absorbance utilizes digital filtering and peak detection. FSR utilizes just peak detection. Thermistor simply calculates the temperature based on a linear relationship. The Grapher allows the user to create an interface tailored to their needs so long as they implement a few methods. The framework created forces the user to conform to these standards for graphing; this normalizes the interface between different users.

## Testing

Testing was conducted on an anesthetized rat late in the semester. By that time, a Java interface was written and the circuit boards had been modified. Unfortunately, signal processing algorithms had not been implemented. Without a good signal the signal processing would fail. Thus, one of the team's goals was to test the small animal pulse oximeter probe obtained from the client. The team also wanted to determine if the previously implemented digital filter was sufficient for use on a rat.

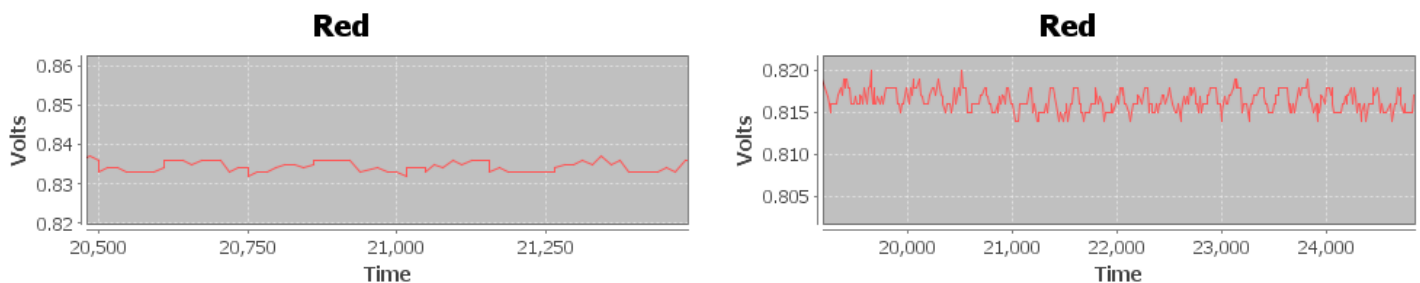

Figure 9: A comparison of the raw pulse-oximeter data (left) with the filtered pulse-oximeter data. This data came from an anesthetized rat. The filter used was a precursor to the final filter, which offers a smoother signal.

The original filter was an Infinite Impulse Response filter. The filter proved it works for the high frequency data encountered when monitoring rats. However, this filter was discarded when peak detection on the somewhat noisy signal proved difficult. A new difference filter was implemented on the hardware. This filter helped create a much smoother signal, which was then easy to analyze using peak detection algorithms.

The final signal processing and filtering algorithms were tested on several human subjects. An addition to the Java interface allowed easy determination of the accuracy of the final algorithm. Whenever the algorithm detects a peak in the signal, a line describing this detection is drawn on the graph itself. Because it is simple to manually analyze a  $SpO_2$  and FSR signal for peaks and troughs, this technique is adequate for verifying the detection algorithms. Although peaks are missed when large motion artifacts are detected by the probe, the program is extremely capable of detecting the correct peaks when given normal absorbance data. A similar algorithm was implemented to the FSR aspect of the design. Although the final algorithm was tested to be accurate on humans, no rat was available late in the semester. Testing to verify the adequacy of the filter values for rats will be conducted on a later date.

## Ergonomics

During the design of the user software and hardware, human interaction with the vitals monitor was a major factor. The device must be, at a minimum, operable by someone with computer knowledge as their only experience with electronics. The Java GUI was designed to be exceptionally user-friendly, and all measurement probes require minimal setup with respect to each animal, and are simply connected into the circuit housing unit.

As seen in Figure 1 (pg.3), there already is a significant amount of equipment present in the laboratory setting that our client and his research assistants work in. Therefore, the device should not add any clutter to the research environment. There will already be 12 external wires, one for each probe, and a cord for the power supply, so any additional external wiring should be avoided at all costs. This spatial constraint and the user-friendliness requirement are the main reasons why the previous team used the familiar Wi-Fi option for the method of data transfer (in addition to its high speed). There was not enough time to implement Wi-Fi on the completed prototype this semester.

The software developed and sold today is often user-friendly; hence, consumers have come to have inherent expectations of any software they use. They expect the interface to be clean and allow them to find what they are looking for with minimal effort. For software that integrates with hardware (such as this project), there should be minimal effort to establish communication between the two. These factors were taken into consideration during software design. The interface is clean, presenting all the important information well labeled. Additional information, that is not important to the user, is not displayed. The software also automatically detects the device, and if not present, a friendly message is displayed to the user. In the future, an instruction manual will be created to aid with any and all problems likely to be present while utilizing the prototype.

As previously explained, the pulse oximeter probes have a fairly simple and robust design. This ensures that the research assistants are not required to perform any alterations or extraneous manipulations when applying the clip the hind paw of the rats. Additionally, the probe is easy to clean after each use and the LED/photodiode are not exposed to any cleaning liquids as they are encased within plastic. After each testing session, the research assistant was able to effectively clean the probe by using a small alcohol wipe.

## Ethical Considerations

Animal safety is the main ethical consideration in the design of a quad rat vitals monitor. The client has specified that all probes used in the final design should be non-invasive and cause no harm to the rats. During each test run performed this semester, all governmental and university standards regarding proper animal care were carefully followed [14]. Since none of the team members are qualified to handle animals, the research assistant was the only person who applied probes to the rat. In the future, when a housing device for the circuit boards is manufactured, the animals will be completely isolated from any wiring or circuit elements that could cause harm. To finish, it is important to note that the design of a quad rat vitals monitor is to serve the sole purpose of a diagnostic tool, and should not replace any standard small animal laboratory procedures. The final design will be able to accurately notify the researcher when the vital sign of any rat enters a critical range; however, it is not designed to prevent any rat from entering into such a critical range.

## Cost Analysis

Funding for the project went towards additional parts for the circuit boards. These additional parts improved the accuracy of several chips, providing a higher level of confidence in the results. Parts were ordered from Digi-Key® for \$65.95 as well as Mouser Electronics for \$97.29. Table # includes the expenses for the project to date, including previous semesters. The team expects that the majority of the remaining money will be used for purchasing pulse oximeter probes.

Table 1: Project finances to date

Date	Vendor	Item	Cost
11/10/2008		NI USB-6008 (2) data acquisition electronics	\$320.00
12/15/2008		(approx. date) WC poster (approx. charge)	\$50.00
4/1/2009		(approx. date) op amps not incl. shipping	\$19.00
4/15/2009		(approx. date) +/-5V supply not incl. shipping	\$20.00
11/10/2009	Digi-Key	electronics parts (approx. charge)	\$50.00
11/10/2009	Newark	electronics parts (approx. charge)	\$50.00
11/13/2009	Mouser	electronics parts	\$59.01
11/12/2009	Digi-Key	electronics parts	\$4.50
11/17/2009	Digi-Key	electronics parts	\$17.17
12/3/2009	CDW-G	Lenovo laptop computer	\$659.68
4/22/2010	Sunstone	Printed circuit boards	\$538.00
4/12/2010	Digi-Key	electronics parts	\$363.22
4/23/2010	Radio Shack	electronics parts	\$30.55
11/18/2010	Digi-Key	electronics parts	\$65.95
11/18/2010	Mouser	electronics parts	\$97.13
		TOTAL	\$2,344.21

## Vision for the Project

The following is an updated version of what is presented in Bollom, et al. It lays out suggestions for the development of the remainder of the project.

When this project was first started in Fall 2008, no one could have predicted the turns this project has taken. This is certainly an ambitious project that presents many difficult hurdles, but it also presents the opportunity for learning. After this semester, the individual board hardware and framework for the software has been completed. To guide future design, the team presents their vision for the project.

Mouse Ox is a product that does part of what this project aims to do. It is expensive at about \$7000 for one machine, and this does not monitor temperature. For the client to utilize this setup in his laboratory, he would require four of these devices, plus another method to monitor temperatures. The team has aimed to make this project a reasonable expense for him as well as anyone else who may desire such a system. Hardware was designed with extensibility in mind; the system should work as well for monitoring one rat as it does for four rats. Minor interface tweaks will be needed to scale the interface from one rat to four rates, but such details are trivial and could potentially automatically adjust depending on how many devices are detected.

Now that a good signal has been obtained from a rat and signal processing has been initially developed, extensive testing must be performed. The heart rate and blood oxygen saturation algorithms work well on humans, but they must be tested on rats as the signal amplitude is much less than that on humans. The modified filters programmed at the end of the semester should help increase signal amplitude, but some changes to the LED current levels may be needed.

Because the framework for the user software is in place, it is easy to tailor interfaces. With the hard portion of the signal processing out of the way, what remains is to implement data auto-saving, and the history graphs the client desires.

Although there is plenty of processing power available on the project laptop, it is possible to do all the necessary calculations on the microcontroller. This will involve implementing digital filtering, peak detection, and various calculations to arrive at the vitals. With the Java framework in place, it should be relatively easy to port the signal processing to another platform.

To enable wireless data transmission, a Gumstix would be a viable option. However, since this project's focus is on monitoring four rats simultaneously, the team believes a separate motherboard would be the best option. Four boards can communicate with each other via I<sup>2</sup>C. I<sup>2</sup>C allows for a unique identifier to be tagged to each board, so it would be easy to determine where the signal came from. The motherboard would take this data, perhaps perform some signal processing if feasible, and then send this data to a Wi-Fi chip. This Wi-Fi would then send the data out to any listening clients. This would require the implementation of the I<sup>2</sup>C protocol into the pulse oximeter programming as the hardware for I<sup>2</sup>C is already mostly in place.

When all hardware and software is working, an enclosure for the project is needed. The team suggests a variant of the *Toaster Oven* design as presented on page 47 in Bollom, et al., but there is certainly room for improvement. A small footprint of the device is desired, because the entire device should be able to be stored and should remain out of the way during testing sessions.

With all components considered, an individual pulse oximeter board (including FSR and thermistor) will cost approximately \$95.00 plus some additional expenses for the probes, housing, and a computer if necessary. Since Java is open source, it is easy to obtain and is free, and it runs on most computers. When additional boards are coupled together, a multiple rat vitals monitoring system is not financially out of reach for research laboratories around the world. While low cost (compared to competitors) was not an original goal of the project, the team suggests keeping the implications of increasing cost excessively in mind.

## Conclusion

This semester, the team has built four functioning circuit boards. These circuit boards enable the measurement of breathing rate, blood oxygen saturation, temperature, and heart rate. The data is acquired via an analogue to digital convert and sent to a computer.

The team also created user software using the open-source programming language Java. The program allows for data acquisition, signal processing (including digital filtering and peak detection), and a user interface. The framework created is extensible such that it can be readily expanded to four rats.

In the future, the team hopes to expand the system to four rats. Currently, there is only capability to monitor one rat; this must be expanded to four to meet the client's requirements. The team also hopes to implement wireless data transmission and build a housing device to hold all electronics and provide an easy interface to connect probes.

## References

- Ho, J. et al. *Quad Rat Vitals Monitor*. Department of Biomedical Engineering, University of Wisconsin – Madison 2009.
- Bjerregaard, R., Klavas, D., Collins, C., Bollom, M. *Design and Construction of a Quad Rat Vitals Monitor*. Department of Biomedical Engineering, University of Wisconsin – Madison 2009.
- Bollom, M., Collins, C., Bjerregaard, R., Klavas, D. *Design and Construction of a Quad Rat Vitals Monitor*. Department of Biomedical Engineering, University of Wisconsin – Madison 2010.
- Webster, J. G. (ed). *Design of Pulse Oximeters*. Philadelphia: IOP Publishing Ltd 1997.
- Federal Laws, Policies, Guidelines, and Other Documents. Retrieved March 8, 2010 from <http://www.iacuc.org/usa.html>.
- Decker, MJ et al. *Noninvasive oximetry in the rat*. Biomed Instrum Technol. 1989 May Jun; 23(3):222-8.
- Starr Life Sciences™ Corp. ©2009.

## Appendix