



Automated Uretero-Intestinal Anastomosis with Absorbable Staples



Samantha Paulsen¹, Jeffrey Theisen¹, Vanessa Grosskopf¹, Matthew Bollom¹
Advisor: Willis Tompkins, Ph.D.¹ **Client:** Tracy Downs, M.D.²

¹Department of Biomedical Engineering, ²Department of Urology

Abstract

Bladder cancer is the 5th most common cancer in the United States. When cancer cells invade the bladder muscle, surgical removal of the bladder, called radical cystectomy, is the desired treatment. A neobladder is formed out of a portion of intestine, and the ureters are currently attached via absorbable sutures. The team has developed a rigid absorbable staple comprised of 85:15 poly(lactide-co-glycolide) (PLGA). The copolymer is compression molded, then cut to the desired shape with an Epilog CO₂ mini laser cutter. Degradation testing shows that the staples will retain strength for at least 20 days, long enough to promote healing of the tissue. Functional testing shows comparable grip strength relative to Vicryl sutures.

Background

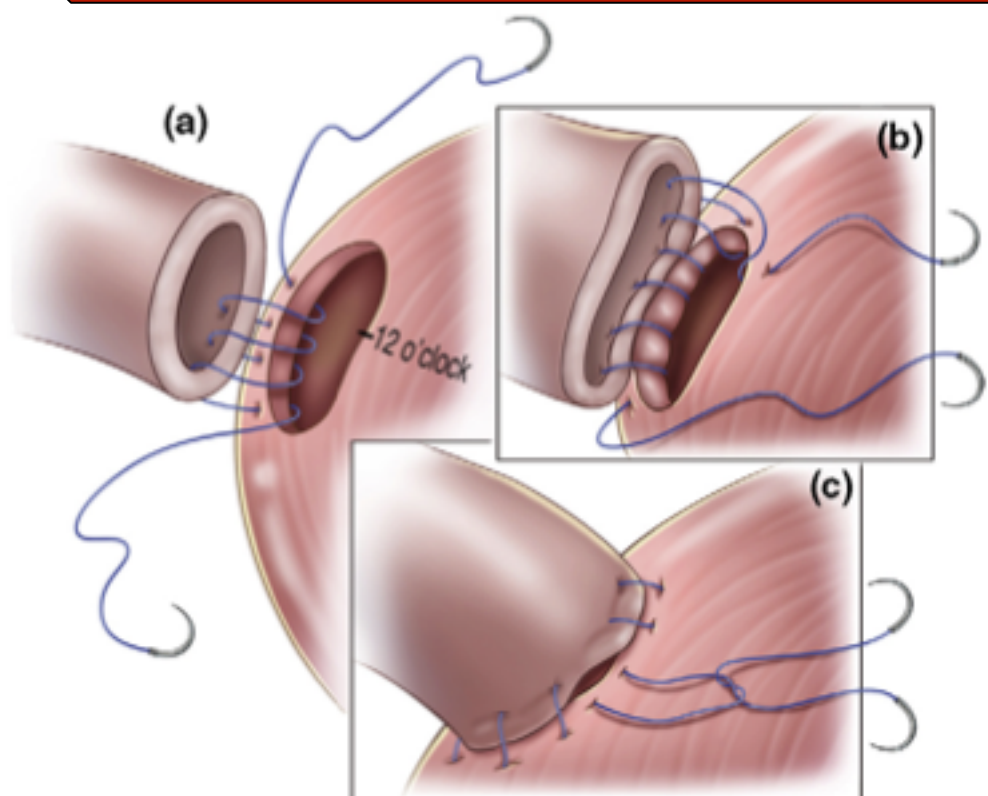

Figure 1: Ureter attachment to neobladder via suture [1]

- Radical cystectomy – surgical removal of bladder when cancer invades muscle
- Ureters attached to neobladder via absorbable sutures
- Procedure lengthy and inconsistent between surgeons
- Desire to automate process

Current Devices

- Previous design project:
 - Staples 90:10 PLA:PCL cross-linked with 10phr DCP
- Absorbable sutures (Ethicon Monocryl and Vicryl)
- Anastomosis circular staplers (Ethicon, Covidien)
- Absorbable Staples (Inorb, Covidien)

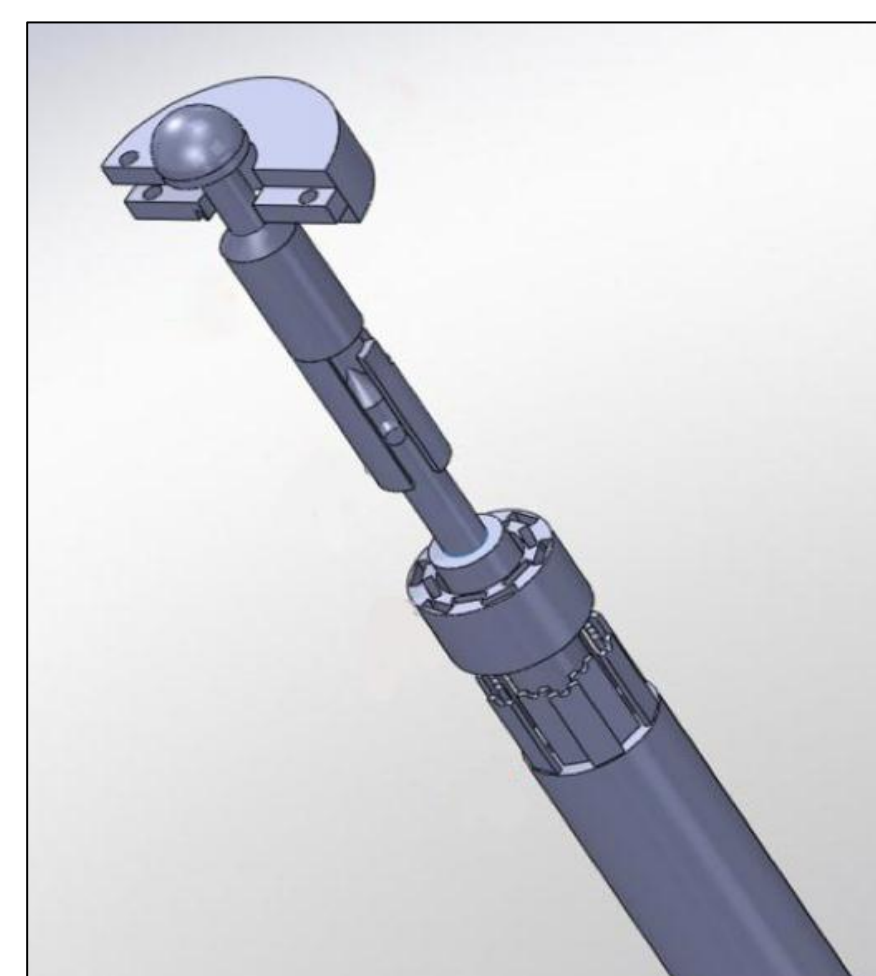

Figure 2: Stapler head designed by previous team



Figure 3: The Ethicon Endo-Surgery Intraluminal Stapler [2]



Figure 4: Inorb staple [3]

Device Requirements

- Biocompatible
- Secures ureter to neobladder for a minimum of 30 days
- Creates a water-tight seal
- Withstands bladder environment
- Does not damage surrounding tissue
- Sterile

Staple Design

- 85:15 Poly(lactide-co-glycolide)
- PLGA is widely used for absorbable applications, thus easily approved by FDA
- Reported to degrade in ~60-70 days
- Multiple alternating barbs to secure staples and account for variable tissue thickness

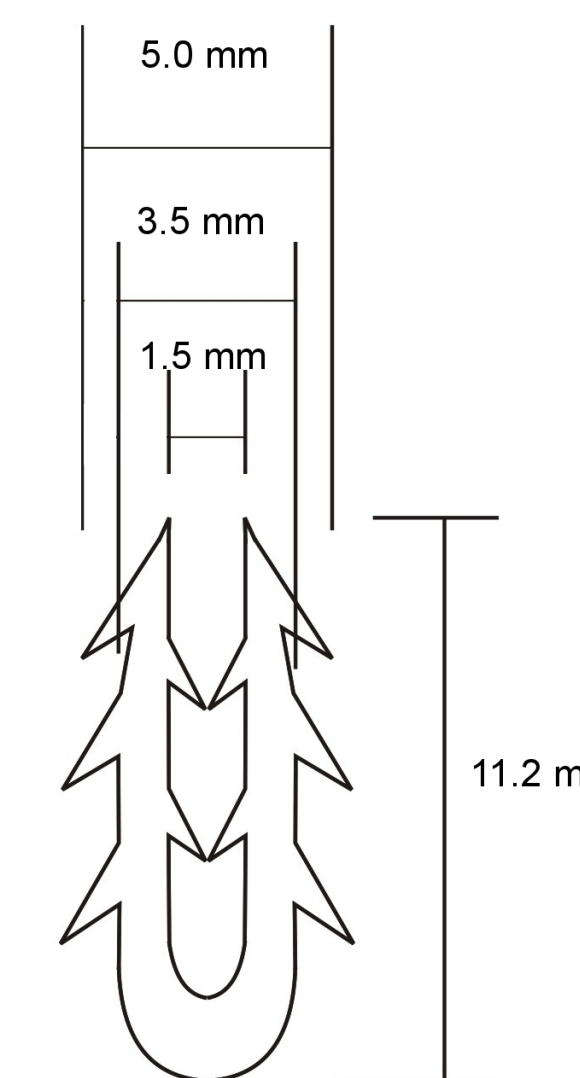

Figure 5 (right): Line drawing used with the laser cutter

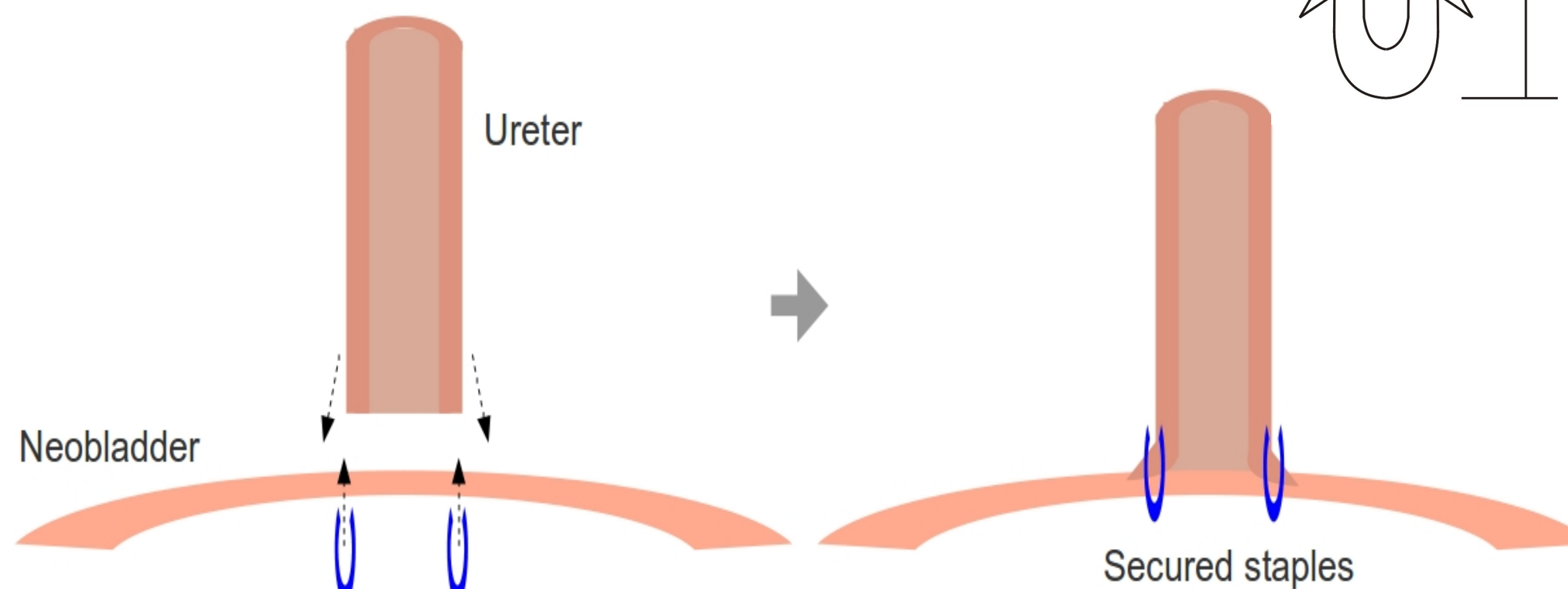

Figure 6: Proposed staple mechanism for uretero-intestinal anastomosis

Fabrication

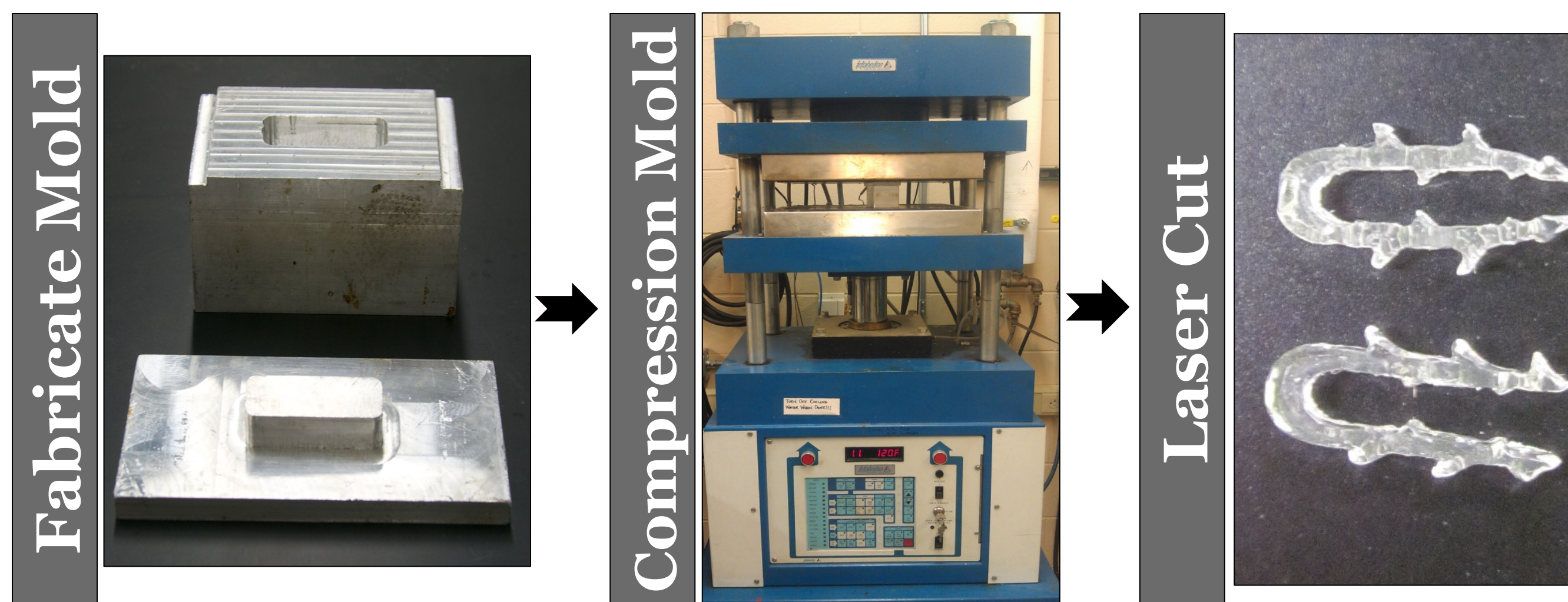

Figure 7: The team first designed a mold to form a 1mm x 16mm x 45 mm sheet of PLGA. The team then compression molded the sheet and finally cut out the staples and tensile test samples using an Epilog CO₂ mini laser cutter.

Testing

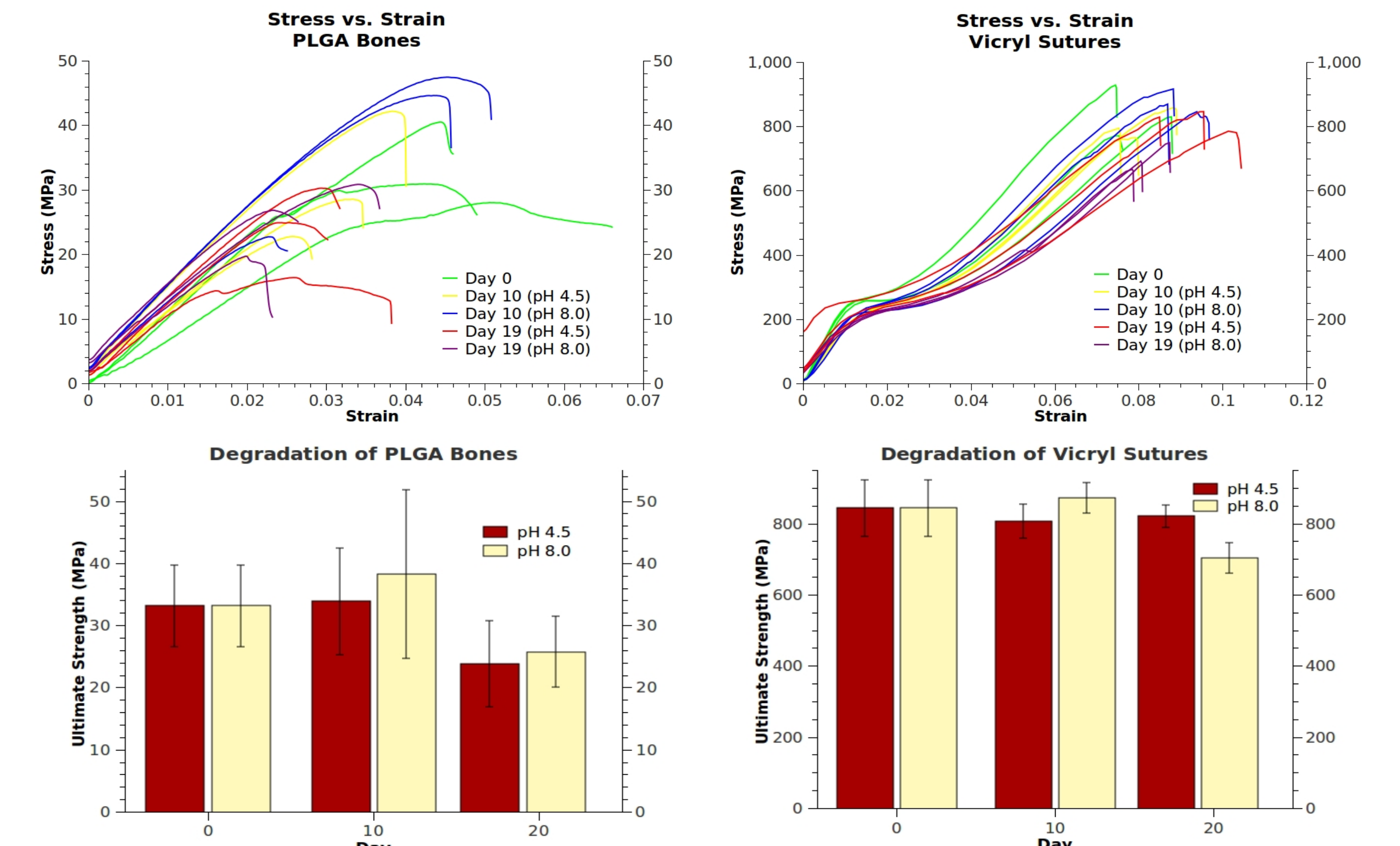

Figure 8: Tensile testing and degradation data

Test	1	2	3	4	5	Average	p-value
Force to Remove Staple (N)	2.4	2.9	4.4	4.5	4.5	3.74 ± 1.01	0.85
Force to Remove Suture (N)	2.0	2.6	2.2	6.0	5.0	3.56 ± 1.82	

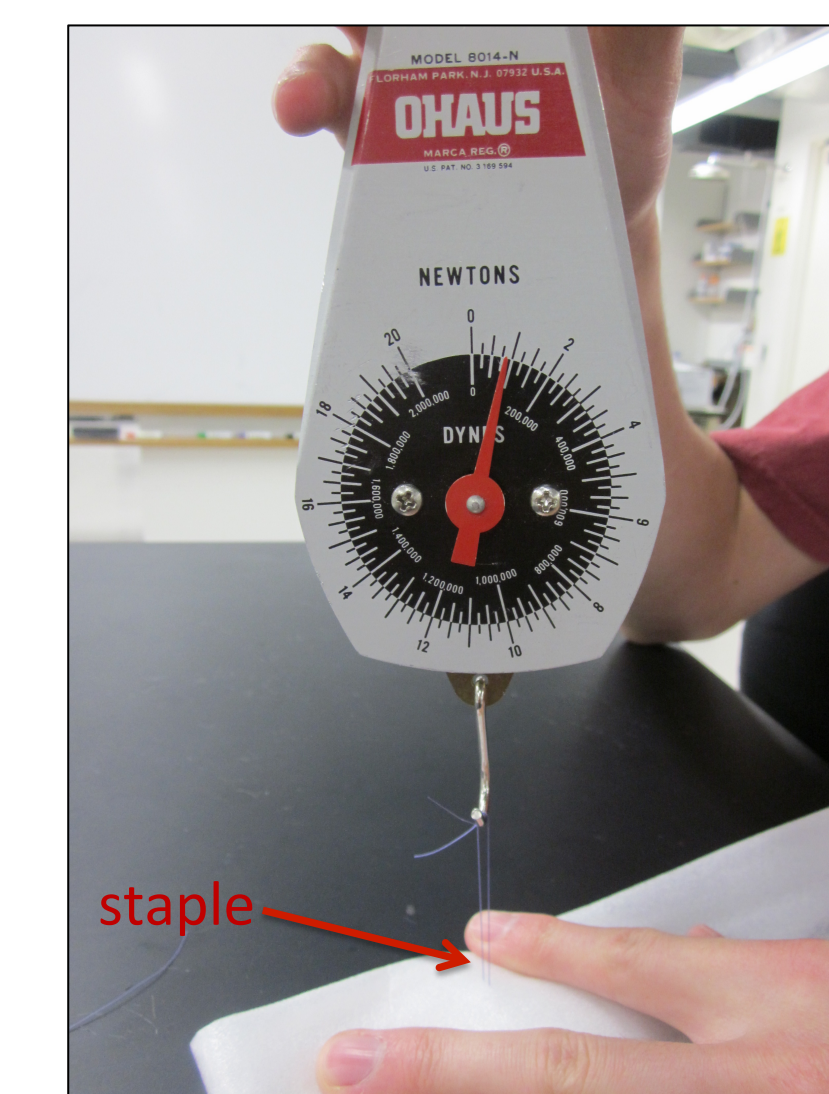

Figure 9: Functional test setup

Table 1: Functional testing: force required to remove staples and sutures

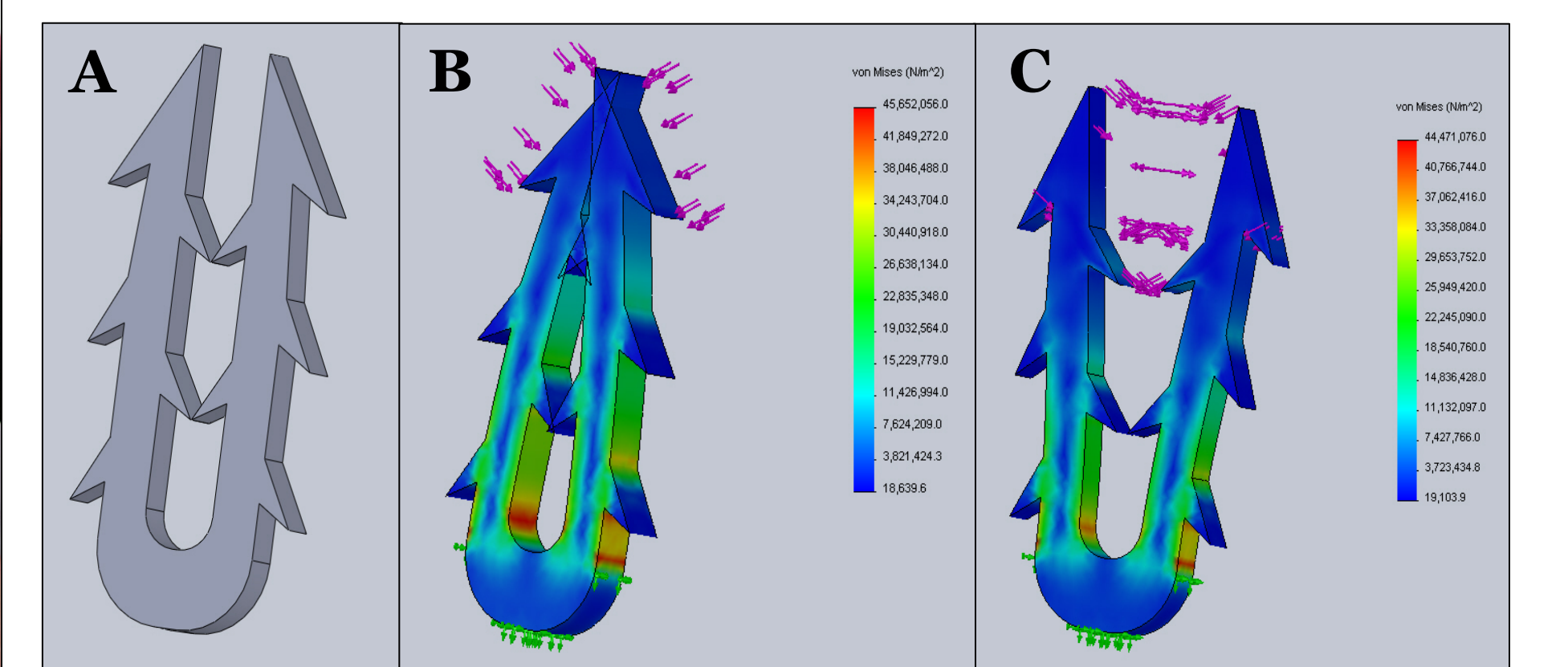

Figure 10: (A) SolidWorks drawing for the final staple design. (B & C) Von Mises stresses for fixture (shown in green) and loading (shown in purple)

Future Work

- Redesign stapler
- Refine staple fabrication process
- Additional degradation testing
- Additional tensile testing
- Continued functional testing (animal models)

Acknowledgements:

Professor Willis Tompkins, Dr. Tracy Downs, Professor Tom Turng, Professor John Puccinelli, Professor Tim Osswald, Scott Johaneck, UW Student Shop, Professor Bill Murphy, Tom Mulholland, Graham Fischer, Purac Biomaterials, Professor Wendy Crone, Shusta Lab

References

- [1] Murphy, et al. 2009. Operative Details and Oncological and Functional Outcome of Robotic-Assisted Laparoscopic Radical Prostatectomy: 400 Cases with a Minimum of 12 Months Follow-up. *European Urology*. Vol 55: 1358-1367.
- [2] Circular Staplers + Intraluminal Staplers. *Ethicon Endo-Surgery*. (2010). Retrieved September 15, 2011, from <http://www.ees.com/Clinician/Product/stapling/circular-intraluminal>.
- [3] Instructions for Use: All 2000 Series Staplers. *INSORB*. (2009). Retrieved October 17, 2011, from http://insorb.com/documents/IFU_English_20xx.pdf.

