

Animal Bed Controller

BME 300/200
University of Wisconsin-Madison
Department of Biomedical Engineering
December 13th 2011

Group:

Michael Rossmiller – *Leader*
Jeff Groskopf – *Communicator*
Yu “Alpha” Liu – *BSAC*
Cal Buelo – *BWIG*

Client:

Dr. Rock Mackie & Surendra Prajapati
University of Wisconsin-Madison Department of Medical Physics

Advisor:

Paul Thompson
University of Wisconsin-Madison Department of Biomedical Engineering

Table of Contents

Abstract.....	3
Motivation	4
Client Requirements	4
Existing Devices.....	5
Ethics.....	5
Ergonomics.....	6
Design Proposal Overview	6
X, Y, Z Linear Actuators	6
Rotation Designs.....	7
Design 1: The Spit.....	8
Design 2: Springs & Strings.....	9
Design 3: Stepper Motors	10
Design Evaluation	11
Final Design	13
Testing:	15
Future Work	18
References	20
Appendix:.....	21
Budget.....	21
Project Design Specification Report	21

Abstract

An animal bed positioning system is to be developed for an open source micro CT, PET, and RT system. This positioning system must have at least four degrees of freedom: translation on the X and Y-axes, and rotation around the X and Y axes. This system must be very precise with step sizes of 200 microns for translation and 0.1 degrees for rotation. It was decided that our system would use two linear actuators and two stepper motors by a design matrix. The system will use two Firgelli L12 model P linear actuators paired with two Firgelli linear actuator control boards, as well as two Phidgets Inc Bipolar Planetary Gearbox Stepper motors paired with two Arduino Uno boards.

Problem Statement

Nowadays, image-scanning devices such as the CT, PET, and RT scanner could cost up to several million dollars. These medical devices can only be afforded by big hospitals or research centers with considerable financial capability, when they too are needed for medical research in other places, especially in developing countries. Currently existing scanning systems also are constrained by the numbers of degrees of freedom, as they can only perform translational movements in two directions. As needs for more detailed medical research, disease analysis and physical check rise, a CT, PET, and RT scanner model that can be obtained in an easier and more affordable way would be ideal. This will allow more people to participate and contribute in any medical field involving these scanners, which they might not be able to perform in the same way nowadays due to financial constraint. In addition, this model should be more task-oriented and consists of more degrees of freedom including one more direction for translation and two for rotations, which allows more in depth looking into testing subjects. A model described above can be acquired by lowering its cost of materials, and assembling new components for more degrees of freedom.

Background

Current medical practices often require medical imaging and treatment systems to diagnose and treat patients, for example x-rays, CT, PET, MRI, etc. Medical research is often conducted on animals, testing new drugs and procedures with the goal of improving health care for people. These animal patients (such as mice and rats) are smaller in size than humans, and require scaled down versions of the systems used with human patients.

Micro CT, micro PET, and micro RT systems have been developed to better image and treat the smaller bodies, organs, and tumors of animal subjects. These systems function analogously to those used on humans, however with finer resolution imaging and treatment. They are also smaller and less

expensive than the systems used on humans. To achieve precision in imaging and radiation treatment, precise patient positioning is required in the imaging and treatment fields.

Our client, Surendra Prajapati, is a graduate student working on the Open-Source Medical

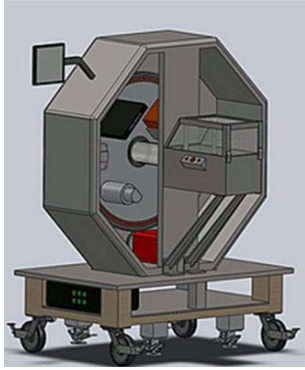

Figure 1 – SolidWorks drawing of overall open source the imaging and therapy system (Prajapati, 2011).

Devices project at Morgridge Institute for Research. This project is working to create an open source small animal imaging and radiotherapy system with micro CT, micro PET, and micro RT (Figure 1). Because it is open source, the design for this system will be freely available and will be less expensive to build than buying a commercially available system.

Our group will be designing the motion control system that will be used to position the small animal. The user will attach the animal bed (which secures the sedated animal) to our motion control system in the loading area,

then use the control system to move the animal into the imaging bore. Once inside the imaging bore the motion control system will precisely positioned the animal bed in the imaging field. The motion control system will be designed to be more precise than positioning systems in commercially available imaging systems by incorporating more degrees of freedom, and also to be less expensive to keep the cost of the entire imaging and therapy system low.

Motivation

CT and PET scan systems can be very useful devices for research. Dr. Matthew Jensen and the rest of his team of research assistants use the Siemens Inveon micro CT and PET scanner, in the Wisconsin Institutes of Medical Research, weekly. They use the device to measure stroke volume and glial scarring in rats (Ostergaard Interview, 2011). The combination of the two systems allows for the subject to only have to be put under anesthesia once to get two separate images. There are other devices on the market, but these systems can cost upwards of a million dollars. Our client is currently designing an open source system that will hopefully cost fractions of that. He would eventually like to put all of these designs and specifications on the web, thus giving many more the opportunity to share their research and ideas with the world.

Client Requirements

The animal bed positioning system must fit into a 12 cm diameter borehole. The positioning system must have four degrees of freedom: translation on the X and Y-axes, and rotation around the X and Y-axes. The system must be able to accommodate movement in the Z-direction. It must have

precision along the X and Y axes of 200 microns up to 1 cm in both directions. It must also have rotational precision of 0.1° with up to 5° of rotation on either side. The entire system should also not exceed a budget of \$500.

Existing Devices

There are currently small animal imaging and radiotherapy systems commercially available which incorporate small animal positioning systems in their designs. However these positioning system designs usually have fewer degrees of freedom than our client requires and/or are more expensive than is desirable for an open source project.

Two examples include the Siemens Inveon system and Johns Hopkins University's SARRP.

Our group went to see the Siemens Inveon system (Figure 2) at the Wisconsin Institute for Medical Research. Inveon is a modular system that can combine micro CT, PET, and SPECT. This system had only two degrees of freedom, z and y translation. It utilized motors which turned screws to move the platform into and out of the imaging bore and vertically up and down.

Another example of a small animal imaging and radiotherapy system with a positioning system is the Small Animal Radiotherapy Research Platform (SARRP, Figure 3), which was developed at Johns Hopkins University. It has 4 degrees of freedom (X, Y, Z, and yaw/ θ) and does both CT and RT. Xstrahl Ltd has commercialized the SARRP system (Verhaegen, 2011).

Ethics

Image scanners are applied to generate three-dimensional image of living subjects' complex interior for further body examination or disease analysis. This process highly requires sharp precision; as a result, although one of the objectives about this open source project is to make the total cost as low as possible, this micro CT/PET/RT scanner still should be able to perform with high accuracy, and for at least a certain lifetime. Therefore, design methods and material selections are crucial and should still be chosen in priority based on the feasibility and reusability of the potential product. Cost will be considered at last to avoid excessive precision. Specifically, components for three translational and two rotational movements have to at least achieve the required precision specified by the client.



Figure 2 - Siemens Inveon system (Siemens, 2008).



Figure 3 - SARRP system (Verhaegen, 2011).

Ergonomics

The design should be convenient and safe for the user to operate. During typical operation the user will only have to attach the animal bed to the motion control system and close the loading area cover. However, the user may need to adjust or replace parts of the entire system; for this reason the design should include parts that are fairly easy to change and no sharp edges.

After attaching the animal bed and closing the loading area, the user will interact with the interface of the design to control the bed's position. This will take the users' input and use it to move the animal bed. Our design will probably use a prototyping microcontroller such as an Arduino to convert the input to a movement. This could be integrated into the imaging and radiotherapy system's interface once the entire system design is finished.

Design Proposal Overview

A system is being designed to give a specimen table or animal bed four degrees of freedom with high precision to allow a specimen to be situated in exactly the same position for each imaging or therapy session. This design

will be part of an open source small animal imaging and therapy system that includes micro CT, PET and RT scanners. The four degrees of freedom this design is required to move in are translation along the X and Y-axes, and yaw and pitch, figure 4. The animal bed needs to have the ability to reposition 1 cm in the positive and negative X and Y directions. This system is required to have 0.2 mm or 200 micron precision along the X and Y planes. The animal bed also must be capable of rotating $\pm 5^\circ$ with 0.1° precision in both the yaw and pitch directions. The overall system should be designed to allow a user to precisely and easily position the animal bed. The design should also permit the animal bed to be facilitated with probes and equipment to measure specimen's vitals and keep it alive and unconscious during imaging and therapy sessions. The bed should also accommodate a possible heating element to keep the subject warm during testing. The designs below focus on accomplishing the four degrees of freedom the table will move in by splitting the linear and angular motion designs. The first design accomplishes the X and Y linear motion the animal bed will move in. This X and Y system can be attached to one of the three alternative designs for the angular motion, yaw and pitch, to give the system four degrees of freedom. Each angular motion design provides a unique movement process.

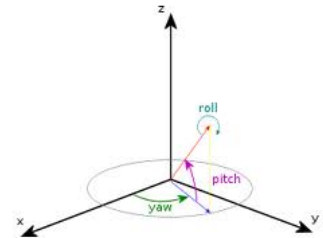

Figure 4 - View of X, Y, Z, Yaw, Pitch, Roll. <forums.eventscripts.com>

X, Y, Z Linear Actuators

The focus of this design is the movement along the X, Y and Z axes and provides three of the five required degrees of freedom for the overall system. This design uses three separate linear actuators that

each move along one plane. These three actuators will be secured together, as in figure 4, to form a system that will allow for a specific (X, Y, Z) coordinate to be reached. Using this type of configuration, the animal bed will be able to be move along the X, Y and Z axes.

Since this design configuration will need to support the weight of several components such as the other two linear actuators, the animal bed, the specimen and the design for angular motion, a liner slide actuators, figure 5, will be used to move along the Z axes. This linear slide will provide the overall system with a sturdy support. A linear slide also supplies the system with long, precise movement along the Z axes that uses position feedback to ensure its positioning (Zaber, 1997). These advantages that a linear slide provides, helps to fulfill some client requirements.

The other two actuators will only need to each move a net distance of 2 cm but must be able to fit within the bore of the system and have sufficient strength to move the remaining system. Therefore, to move in the X and Y directions, electro-mechanical linear actuators will be used. These actuators operate by using DC or stepping motors to extend and retract in a repeatable manner (GlobalSpec, 1999). These actuators are also cost effective, come in a variety of sizes and have a positive feedback system to provide the required accuracy (GlobalSpec, 1999). Due to these factors, electro-mechanical linear actuators satisfy client requirements and provide the movement along the X and Y axes.

Our design will incorporate the use of two Firgelli L12 model P linear actuator, as seen in figure 6, to move our system in the X and Y plane. These actuators need a Firgelli Linear Actuator Control board, LAC in figure 7, to function. The LAC connects to the computer via a micro-USB cable which allows a program to control the exact position of a L12-P actuator. These actuators have 0.20 mm accuracy and extend to a max length of 30 mm.

Using a linear slide for movement along the Z axes and two Firgelli L12-P linear actuators for the position in the X and Y plane, this design successfully will satisfy the client requirements. This configuration provides the system with three of the five required degrees of freedom. The Z actuator will not be focused on currently and will be a part of our future work on the design.

Rotation Designs

By separating translational movement and rotational movement, it allows for more precision of the animal platform. Also, by separating these it allows for smaller parts which will make them simpler



Figure 5 - shows three linear slide actuators secured together (Zaber, 1997).



Figure 6 – Firgelli L12-P linear actuator (Firgelli, 2010).



Figure 7 – Firgelli Linear Actuator Control board (Firgelli, 2010).

in the long run to not only to create and fit into our designated borehole size, but easier to assemble and build. Described above were the proposed methods of moving the bed along the X and Y-axes, and next the possible methods of moving the bed along the final two rotational degrees of freedom will be talked about.

Design 1: The Spit

For the first design, inspiration was drawn from a pig roast, which is where we get the name “The Spit”. However, instead of rotating about the x-axis, the two ends would be on linear actuators and could then rotate about the y-axis. By changing the z distance of the two linear actuators, an axis of rotation would be created at the center of the animal bed, which would be ideal for our client but not preferred.

The entire system would consist of three linear actuators with the third being in the middle and slightly below the other two. This linear actuator would account for the rotation about the x-axis. This would be possible with a connection made at the front of the animal bed through a system of hinges. If this linear actuator were to slide forward, it would push the front of the bed up. If it were to slide backward, it would pull the animal bed down. After a few calculations were made, it was shown that a step size of 87.3 microns would allow for a rotation of .1 degrees about the y-axis.

Because all three linear actuators would be moving in the z-axis and all three would need to have very small step sizes, this system would allow a greater precision. If all three linear actuators were to be moved together, it would simply slide the bed forward or be pulled backwards. Another benefit of this system is that there will be extra strength in the y direction because of the connection underneath the system, which is shown to the right in the yz plane. When an animal is put onto the end of the bed, a small amount of deflection will be seen. However, because of the extra stabilization, this deflection will be very small and hopefully would be immeasurable.

But by no means is this system perfect, it only accounts for two DOF and has three linear actuators. This may lead to being more expensive than it needs to be because these linear actuators must have very small step sizes and be very strong. This system would also require

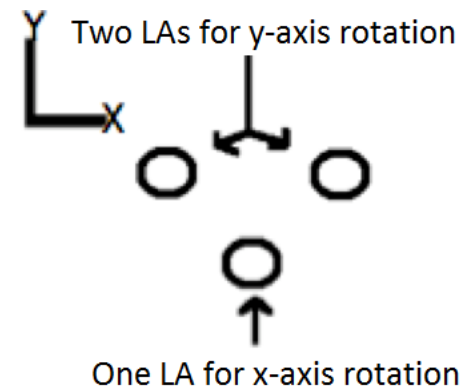

Figure 8 - Shows the position of the three linear actuators in design 1, in the xy plane.

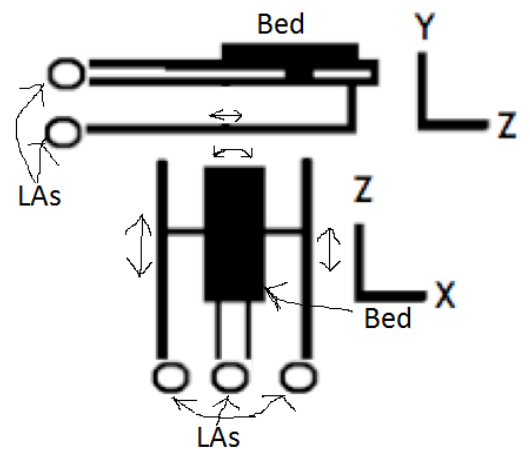

Figure 9 - Shows design 1 in both the xz plane and the yz plane.

a design for a platform to be made. This platform would need to hold all three linear actuators and would add extra weight to the end of the system. This extra weight would add to deflection in the y-axis and would require our xyz-system design to be even sturdier. Also, if it were to be within our clients' guidelines of fitting into the 12 cm borehole, it would need to be made very small, making the rotation of the bed difficult.

Design 2: Springs & Strings

This design is called Springs and Strings. It creates the pitch and yaw rotations by segmenting the end of the arm that extends into the imaging bore with bearings. The bed is on the end of the arm, and rotates around the bearings, as shown below. These bearings are orthogonal to both each other and to the length of the arm.

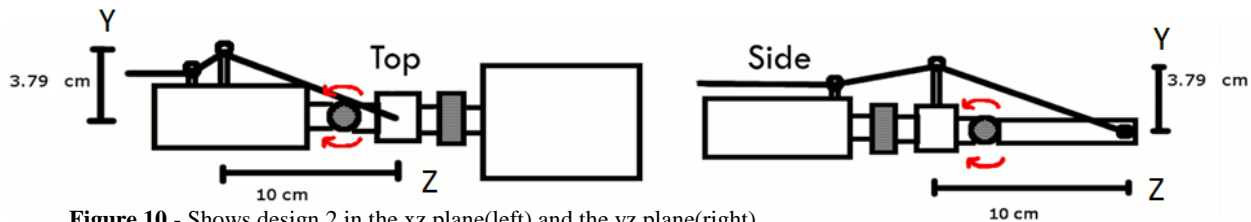

Figure 10 - Shows design 2 in the xz plane(left) and the yz plane(right).

The bed is held in place by opposing forces around each bearing. The force in one direction is created by a helical torsion spring attached to the arm on both sides of the bearings. The opposing force is supplied by a string. One end of the string is anchored to the rotating end of the arm, and the other runs to a linear actuator through a pulley system. The string pulls against the spring around the bearing, with the position of the linear actuator determining the angle that the bed is at. Each linear actuator's position is controlled separately by the user's input. Each bearing requires its own spring and string/pulley/linear actuator system. The linear actuators are anchored to the xyz axes positioning system, away from the end of the arm.

One advantage of this design is little weight is added at the end of the arm because the linear actuators can be moved away and connected by the pulley system. This creates less deflection than a heavier design, which would affect the y-axis position of the bed. Another advantage is that there will be little image attenuation because the only material in the image field will be the animal bed and a small section of string. This design requires no solid supports under the animal bed.

The major disadvantage of this design is that it creates non-constant changes in angle (0.0944 to 0.10 for dimensions given in figure 10 with a linear actuator step of 0.006 cm). The linear actuator creates a constant change in string length, which creates varying changes in angle because the point the string is attached to rotates around the bearing at a constant radius. While the linear actuator's step size and the distance between the string attachment site and the pulley can be selected to create a maximum

angle change of 0.1o (as in Figure x), this complicates the calculations needed to determine the angle of the bed. Another disadvantage of this design is that because it rotates around the bearings and not a point centered on the animal bed, it creates relatively large translations in the x, y, and z directions. These translations would then have to be corrected for by the linear axes positioning actuators.

Design 3: Stepper Motors

This design applies two hybrid stepper motors to perform pitch and yaw rotation. The two motors are linked with a bracket, one on the top and the other one at the bottom, with the top one connecting to



Figure 11 - Shows two stepper motors linked with a bracket, connected to the bottom of the animal bed (Trossen, 2006).

the animal platform as shown in figure 11. The bottom motor will be placed on a base, where linear actuators can be easily attached. The bracket is chosen so that each motor can act independently without changing the angles the other one generates. There is more than one type of stepper motors; hybrid stepper motors generally cost the most due to their ability to generate higher torque and resolution, or smaller step angle (degrees/step).

Stepper motors are operated with an open-loop system, which makes them purely rely on a direct input from an external driver connecting to the motors. An output would go along with numbers of steps motors rotate

(Circuits Note, n.d.). Open loop system eliminates costs for sensing and feedback devices such as optical encoders (Circuits Note, n.d.). The external driver, also called motor controller, can receive information from

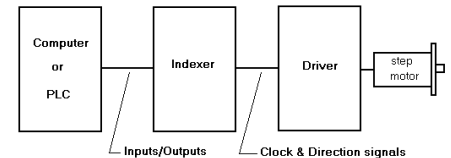

Figure 12 – Flow diagram of commands from the computer to the stepper motor (Anaheim Automation, n.d.).

computer codes and send digital signals of amounts of impulse to the motor, which are the only sources driving it to move. The diagram of how open-loop system works can be seen in figure 12 on the right (Anaheim Automation, n.d.). The number of impulses is proportional to number of steps the stepper motor rotates. These two features make stepper motor easy to control in terms of degrees of rotation, as users only have to input the impulse corresponding to them.

Other than easy to control, model with stepper motors also proves to be capable of accomplishing the required tasks. As shown earlier in the client’s requirement, this scanning model needs to generate turning angles with a precision of 0.1 degree. Stepper motors meet this requirement by utilizing its step angle with the motor controller. Different coding on the controller creates micro stepping on motors and makes each step angle further divisible by up to two hundred fifty six, when each step angle of a stepper motor ranges from 0.9 to 3.6 degrees. Angles up to 0.0035 degree sufficiently fulfill the required precision. In addition to precision, most stepper motors sold also are capable of generating at least 6.5 Kg-

centimeter of torque, when the approximate animal platform weighs 500 grams, or about 2.5 Kg-cm of torque. However, when doing micro stepping, stepper motors do lost some of their torque by a significant amount. Therefore, model designed with stepper motors theoretically is feasible for the minimum requirement, but appropriate stepper motors are needed to be chosen carefully.

Besides the two greatest strengths, easy controlling and feasibility, this design also provides additional benefits. First of all, the two stepper motors are independent from any movements other than pitch and yaw, which impose no possibilities that rotations will interfere with translations or the other way around. In other words, X and Y actuators can just be attached to the bottom motor with no concerns. Moreover, this design is reusable as stepper motors do not wear out easily. Unlike other motors with internal brushes that might wear when being operated, stepper motors rotate through changing of magnetic field due to changing of impulses. This gives stepper motors relatively longer lifetime. Lastly, the cost for this design is inexpensive, as the main components are only two motors and one motor controller. Additionally as mentioned earlier, the feasibility of this design exceeds that of minimum requirement significantly; this is a point where the balance of feasibility and cost can be adjusted to make a prototype that not only qualifies its purpose, but also less expensive.

Design Evaluation

To evaluate the three alternative designs for angular motion, a list of criteria for these designs was developed which includes: accuracy and precision, cost, repeatability, lifetime and feasibility of each design. These categories are weighted depending on their importance to the design and client requirements with a design able to receive a maximum score of 100. Using this grading system, table 1 is a design matrix that was created to help select the angular design to be combined with the X and Y linear actuator system to produce the final design.

Table 1 – Design Matrix for final rotational design selection.

Category	The Spit	Springs & Strings	Stepper Motors	Weight
Accuracy/Precision	20	19	21	25
Cost	15	20	20	25
Repeatability	18	12	18	20
Lifetime	17	15	17	20
Feasibility	5	6	7	10
Total	75	72	83	100

The most important design and client requirement was the accuracy and precision the system will have. This is important to giving the system the $\pm 5^\circ$ with 0.1° precision in the yaw and pitch angular direction. Therefore, this category received a weight of 25. The spit design requires some extra pieces to be made and depends on the accuracy of 3 linear actuators which gives it a score of 20. Springs & strings received a score of 19 for accuracy since it has non-constant changes in angle, it loses some precision. The stepper motors design received the highest accuracy and precision grade of 21 because it only depends on two stepper motors that do rotations based on numbers of steps commanded. .

The cost was also a very important aspect to the overall design of the system. Since the system will be part of an open source medical device, the price of the design needs to be relatively low to give the opportunity for everyone to be able to purchase the necessary equipment to build the system. Needing two linear actuators and additional equipment causes the spit design to have a high cost. This leads to it having the low score of 15 for this category. Both springs and strings and stepper motors designs only use two motors in addition to external control boards, which lead to them receiving the same score of 20. Springs and strings are required to be purchased for the springs and strings design; however, the costs of these are negligible compared to the cost of motors.

These angular designs also need be able to perform their motion over and over again. Repeatable motion is a client requirement and will also allow the user of the system to precisely know what to expect the design to do. Therefore, this category received a weight of 20. Both the spit and stepper motor design received a score of 18 due to that fact that they use motors that allow for repeatable motion. The springs and strings design only received a score of 12 due to the fact that the design moves with inconsistent angle change per each step.

Another important aspect of these designs is the overall lifetime that they will have. These designs must last a long time and be able to handle the wear and tear from constant use. Parts should not be wearing out and needing to be replaced and the system should avoid frequent repairs. This will help to keep the cost of the open source system low and allow for experiments to run without hassle. This caused the category to receive a weight of 20. Again the spit and stepper motor design received an equal score of 17. Since the only parts of these two designs that will need to be replaced are the motors, the lifetime will depend on how long the motors will last. Both stepper motors and linear actuators have long lifetimes and shouldn't need to be replaced often. On the other hand, the springs and strings designs uses pieces of equipment that can wear out. In this design, the springs can lose elasticity and need to be swapped out or the strings can break must be replaced. This causes this design to receive a score of 15.

The final category that the designs were critiqued on was the feasibility to the building of the design. Again, since this is an open source medical device, the system will be built by other individuals. The design needs to be easy to put together to allow for minimal error to occur during assembly,

permitting the system to work properly. This category, feasibility, received a weight of 10. The spit design received the lowest score of 5 due to the extra parts needed to be built and complex set up for it to work properly. The springs and strings design also received a fairly low score of 6. Again this design has additional parts but a slightly more complex setup for proper function. The stepper motor design on the other hand is a straightforward and easy setup. However, as the animal positioning system requires a 0.1 degree precision in rotation, most stepper motors need micro stepping to achieve this accuracy. Nevertheless, micro stepping would greatly decrease motors' torque, which might disable them from turning the animal bed. It is still possible to find stepper motors on the markets that either have sufficiently small step angle to avoid micro stepping, or have sufficient torque that is still able to rotate with bed after micro stepping. This gives design 3 a higher score of 7 for the feasibility of the design.

Adding up all the scores of the criteria, the overall score of each design can be used to select the final design for angular motion. The spit design received a 75, springs and strings a 72 and the stepper motors an 83. Therefore, the stepper motor design will be used in the final design. The final design will consist of the X and Y linear actuator combined with the stepper motors. The stepper motors will need to be configured to the X and Y design to allow the animal bed the four required degrees of freedom. This final design will have the required precision, come at a reasonable cost and satisfy other client requirements.

Final Design

Final design of this project incorporates two Firgelli L12 linear actuators, figure 6, two Phidgets bipolar 26:1 planetary gearbox stepper motors, figure 13, one curved support, and several brackets to assemble all those just mentioned. The assembly can be seen in figure 14 made by Solidworks. Two linear actuators are bounded together in a cross shape, with one of them links to animal bed and the other one to one of the stepper motor on the other side. These actuators control translations in X and Y direction, and that stepper motor controls pitch rotation. The other stepper motor is connected to the pitch stepper motor, supporting everything and generating yaw rotation. The curved-shape support sits right beneath the motor doing yaw rotation.



Figure 13 – Phidget bipolar 26:1 planetary gearbox stepper motor (Phidgets, 2011).

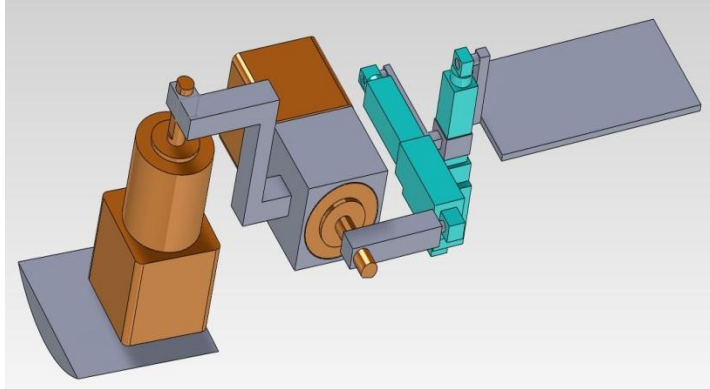

Figure 14 - Solidworks drawing of final design. The animal bed is the platform on the right. The orange components are stepper motors, and the blue are linear actuators.

Still utilizing stepper motors for rotation, but unlike the original design idea shown in design 3, positioning of the motors and linear actuators are modified. This is due to the fact that weights of motors were underestimated in design 3. However, the solution to overcome the problem of losing torque from microstepping came up to be stepper motors attached to gears, which significantly increase the weights. The original design that uses linear actuators to support motors and bed would possibly fail when linear actuators might deflect and influence accuracy. On the other hand, gear stepper motors generate torque up to 30 kg-cm, which is so much higher than the estimated torque to hold the animal bed. Adding two linear actuators, and even one more gear motor on the other gear motor still is feasible without breaking the components or affecting accuracy.

The two linear actuators are controlled by Firgelli linear actuator control board, figure 7, and related software, which allow users to input the percentage they want the linear actuators to extend. The interface provides a feedback system, showing the percentage the actuators have actually extended. On the other hand, the two stepper motors with gears are controlled by Arduino Uno control board, figure 15, and Arduino program. Arduino program was coded so that its interface enables users to input the direction of rotation and numbers of steps they want on the motors. Size of two control boards are thin and small compared to other components so they can easily be included anywhere in final design.

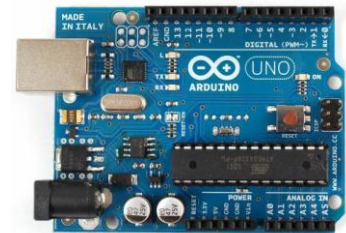

Figure 15 – Arduino Uno microcontroller (Arduino, 2011).

Referring back to design requirements, specifying that final design needs to fit inside a bore hole which is 12 centimeter long in diameter. This is achievable for this design as shown in figure 16, which is the front view of the bore and the model. All components can be fitted in the bore when stationary. Final model should contain four degrees of freedom that includes 2 translations and 2 rotations based on design requirements. This is done as each linear actuator is responsible for one translation and each motor is for one rotation. Moreover, the required moving distance and turning angle can easily be inputted to related program mentioned earlier. Required precision is achieved as well as each gear motor has step angle of 0.067 degree, which is already lower than 0.1 degree precision and micro stepping is not even necessary.

Linear actuators were tested by measuring different extended length with a caliper, and have standard deviation of approximately 0.19 micrometer. Finally, total cost of this design, including two stepper motors with gears that cost 40 dollars each, two linear actuators that cost 90 dollars each, in addition to two Arduino Uno control boards and Firgelli control boards, is 420 dollars (see budget Table in appendix). This is less than the 500 dollars limit. Each item specified in the design requirements is achieved.

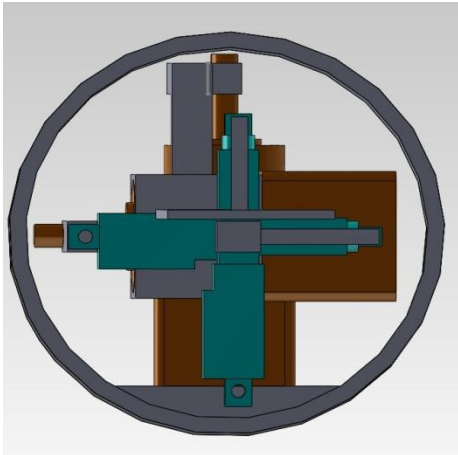

Figure 16 - Solidworks drawing of the final design fitting inside the bore hole in front view. The orange components are stepper motors, and the blue ones are linear actuators.

There is in fact no actual solid prototype constructed currently. This is due to the fact that the selected gear stepper motors require special external circuit which was out of stock, and the brackets and connections between each component require special ordering.

Testing:

Testing of the entire system in the final design will have to be completed after the brackets are fabricated. The geared stepper motors also require additional work before they can be incorporated and tested (see Future Work). The Arduino interface that was created for the stepper motor seemed to be functioning correctly when we controlled a simple stepper motor. The interface took an input and controlled the number of steps the stepper motor took in either the clockwise or counter clockwise direction. Once the additional circuitry is built in the future, the geared stepper motors' accuracy and precision will need to be tested while using the Arduino interface program.

The linear actuators were able to be tested, and we tested one as an individual component to determine the maximum precision and accuracy that can be expected in the entire final system. To perform the testing on the Firgelli L12-P linear actuator combined with the LAC and software to control the position, the

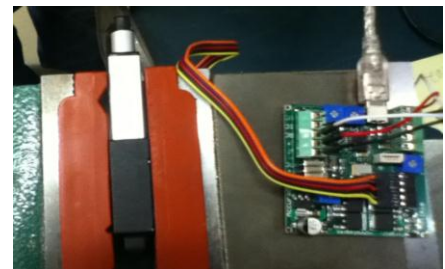

Figure 17 – View of the testing setup with a vice grip holding the L12-P linear actuator that is connected to the LAC board receiving 12 volts of power.

distance between a start point and end point was measured using a digital caliper. As can be seen in figure 17, the L12-P actuator was placed in a vice grip during testing while connected to the LAC that received 12 volts from a power supply. The vice grip supplies a sturdy base that does not allow the actuator to move while measurements of the distance moved are taken.

The LAC control software asks for a percent to be entered in for the distance that the linear actuator should move. At 0%, the distance is unable to be measured; therefore, a starting reference point of 20% was created and measured by the digital caliper at the start of each round of testing as seen in figure 18.



Figure 18 – Measuring the starting position of 20% with the digital caliper.

Testing of the accuracy and precision was performed for extending the actuator three different distances. These distances were 20% to 35% for a 15% change that correlates to 5.00 mm, a 30% change of 20% to 50% correlating to 10.00 mm, and a 20.00 mm distance movement due to a 60% change of 20% to 80%. For each of these distances, 10 measurements were recorded with resetting the linear actuator back to 0% before extending it to the starting position of 20%. Table 2 shows the recorded measurements for all the distances.

Table 2 – Recorded measurement information during the testing of the L12-P linear actuator. All measurements are in mm. The average and standard deviation of the data sets are labeled at the bottom.

Initial (@20%)	Final (@50%)	Change	Initial (@20%)	Final (@35%)	Change	Initial (@20%)	Final (@80%)	Change
6.85	16.85	10.00	6.28	11.56	5.28	6.56	26.85	20.29
6.65	16.53	9.88	6.54	11.58	5.04	6.61	26.99	20.38
6.84	16.89	10.05	6.85	11.64	4.79	6.72	27.08	20.36
6.77	16.65	9.88	6.69	11.97	5.28	6.89	26.98	20.09
6.66	16.63	9.97	6.59	11.72	5.13	6.80	27.10	20.30
6.63	16.73	10.10	6.61	11.55	4.94	6.67	27.06	20.39
6.69	16.81	10.12	6.82	11.58	4.76	6.57	26.83	20.26
6.61	16.55	9.94	6.29	11.51	5.22	6.64	26.89	20.25
6.67	16.73	10.06	6.41	11.37	4.96	6.74	26.81	20.07
6.62	16.51	9.89	6.74	11.72	4.98	6.85	27.08	20.23
Average		9.99	Average		5.04	Average		20.26
Std Dev		0.09	Std Dev		0.19	Std Dev		0.11

Table 3 – The average, Standard deviation and 95% confidence interval calculated values for the linear actuator testing, all in mm.

Linear Actuator Position	Average (mm)	Standard Deviation	95% Confidence Interval (mm)
20-35% (15% Change)	5.04	0.19	4.90 - 5.17
20-50% (30% Change)	9.99	0.09	9.92 - 10.05
20-80% (60% Change)	20.26	0.11	20.18 - 20.34

The measured distances for the data sets had the average, standard deviation and 95% confidence interval calculated. These values can be seen in table 3 and were used to analyze the accuracy and precision of the linear actuators. The average values for the 15% and 30% change were within the required 200 micron or 0.20 mm accuracy. The 60% change lost some accuracy and fell slightly out of the 0.20 mm range of the expected value of 20.00 mm.

This means that when the actuator is moving the max distance it would lose some accuracy. However, this would be a rare occurrence during actually operation. The actuator will normally have a max single movement distance of 10.00 mm. During this movement it will remain accurate within the design requirements.

The 95% confidence intervals for linear actuators at the three different movement distances all have ranges less than 0.20 mm; therefore, it can be known with 95% certainty that the linear actuators will be precise and accurate within the design requirement of 0.20 mm. The precision of the linear actuator can also be seen by the small standard deviations from the testing results all falling under 0.20.

Through this testing, it was noticed that the percent entered into the positioning program did not seem to have a direct correlation to the position the linear actuator was moving. Meaning that the position could not be known simply by entering the percent, because it was not known how the percent translate into an exact distance. Therefore, a calibration curve for the linear actuator was needed and developed. The distance of the actuator was measured at 5% intervals. The results of these measurements can be found in table 4.

These results were then plotted to see the relationship between the entered percent and distance traveled. Figure 19 and 20 show that there is a linear correlation between the percent entered and distance traveled. In figure

Table 4 – Calibration curve data of percent entered and distance measured in mm.

Percent Entered	Distance Measured (mm)
5	1.78
10	3.3
15	5.08
20	6.78
25	8.65
30	10.33
35	12.3
40	13.93
45	15.48
50	17.31
55	18.37
60	20.4
65	22.17
70	23.85
75	25.41
80	27.27
85	29.33
90	31.01
95	31.33
100	31.37

19, values above 90 % leveled. This is mostly likely due to the fact that the linear actuator should not be extended to 100% according to the Firgelli instruction manual. Also, the actual range being used by the actuator in the final design will fall between 0% and 90% were there is a nice linear curve. From figure 20, the calibration equation is $y = 0.3418x + 0.0277$. This equation can be used to find the expected distance move in millimeters when a certain percent is entered as the x variable.

Currently, this equation does not have the greatest accuracy because only single measurements were taken at each point to develop the calibration curve. To improve its accuracy, more data should be collected. Also, both testing results were subjected to human error due to the procedures that were taken. To improve the data collection method, an optical bed or micrometer should be used in the future to record distance that the actuator moves. These methods would remove the human error and lead to more accurate testing results.

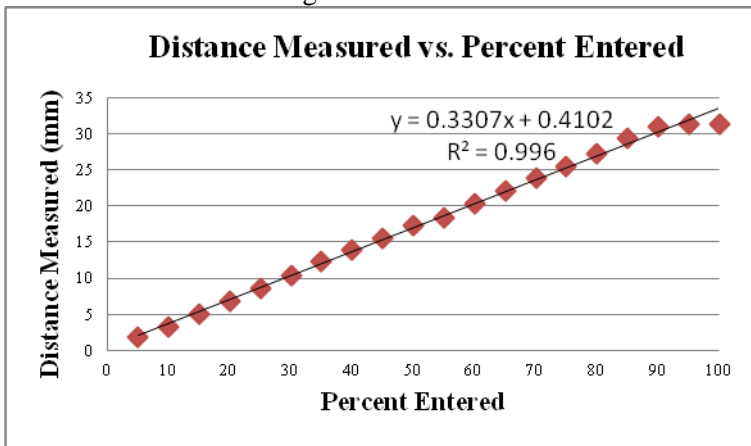

Figure 19 – Calibration curve plot of Distance Measured vs. Percent Entered.

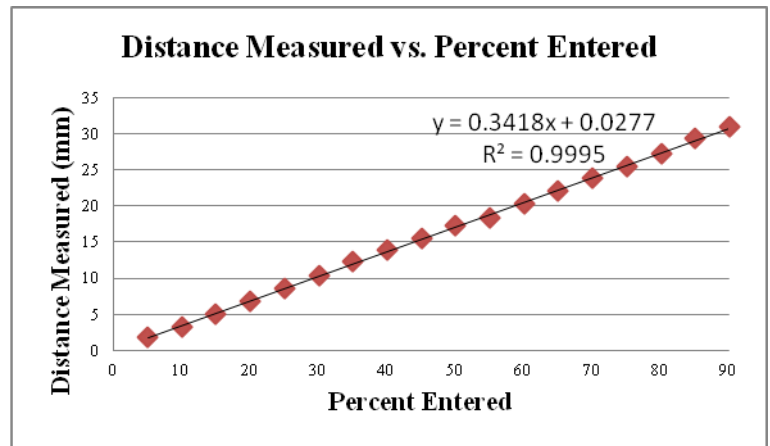

Figure 20 – Calibration curve plot of Distance Measured vs. Percent Entered for Percent entered values of 0% to 90%.

Future Work

The final design has been created in Solidworks and most of the pieces have been purchased, however the prototype still needs to be assembled and additional systems added before it can be used the micro CT/PET/RT. The positioning system itself will require development in these main areas: fabrication of brackets, incorporating the geared stepper motors, addition of a z-axis linear actuator, and consolidation of component control.

The brackets needed to connect all the components are ready to be fabricated from the SolidWorks design from either 3D printing or CNC. The next step will be constructing the circuitry needed to provide sufficient current to the geared stepper motors (or alternatively purchasing the available stepper motor control boards). Also a z-axis linear actuator will be needed to move the platform into and out of the imaging bore. This should be simple to attach with a bracket and controlled identically to the x

and y axis actuators, and for these reasons was excluded from our design and testing due to cost. Finally, control of the entire imaging system should be consolidated to prevent having to use 5 different programs to control the 5 components. Each of the components we used (linear actuators, Arduino controlled stepper motors) had instructions for interfacing them with LabView, so that would be a natural choice to control all the components in one program. After these steps are completed the entire system should be tested for accuracy and precision.

After the positioning system is completed, additional components will be needed for use with animal patients. These include a carbon fiber (or other low attenuating material) animal bed, heating system to keep the patient warm (such as copper coils), and an isofluorine/oxygen delivery system to keep the patient unconscious and alive.

References

Arduino. 2011. Arduino. 20 Nov. 2011. <www.arduino.cc>

Firgelli. 2011. Firgelli Technologies Inc. 1 Nov. 2011. <www.firgelli.com>

"Interview of Peter Ostergaard." Personal interview. 25 Oct. 2011.

Introduction to Stepper Motor System. Anaheim Automation.

<<http://www.anaheimautomation.com/intro.htm>>

Inveon: No Limits On Discovery. 2008. Siemens Medical Solutions. 6 Oct. 2011

<www.siemens.com/inveon>

Linear Actuators Information on GlobalSpec. 1999. GlobalSpec - Engineering Search & Industrial Supplier Catalogs. GlobalSpec. 6 Oct. 2011.

<http://www.globalspec.com/learnmore/motion_controls/linear_actuators/linear_actuators>.

Planetary Gearbox Stepper Product Manual. June 10, 2011. Phidgets. 27 Nov. 2011

<www.phidgets.com>

Prajapati, S. Development of the open source small animal imaging and therapy system. 2011.

<<http://discovery.wisc.edu/morgridge/>>.

Simplifying Motion Control: Linear Actuator and Stepper Motor Controller Specialists. 1997. Zaber Technologies Inc. 6 Oct. 2011. <<http://zaber.com/products/>>.

Stepper Motor Basics. Industrial Circuits Application Note.

<<http://www.solarbotics.net/library/pdflib/pdf/motorbas.pdf>>

Trossen Robotics. 2006. Trossen Robotics, LLC. 6 Oct. 2011. <<http://www.trossenrobotics.com/>>.

Verhaegen, F., Granton, P. & Tryggstad, E. Small Animal Radiotherapy Research Platforms.

IOPscience. 2011 Phys. Med. Biol. 56 R55. <<http://iopscience.iop.org/0031-9155/56/12/R01>>.

Appendix:

Budget

- Two Linear Actuators:
 - Firgelli L12, model P = \$90
 - Firgelli LAC = \$40
- Two Stepper Motors
 - Phidgets Inc, NEMA 17 Bipolar Planetary Gearbox Stepper = \$40
- Arduino Uno = \$40
- **Total = \$420**

Project Design Specification Report

Bed Controller

Group: Michael Rossmiller- Leader

Jeff Groskopf- Communicator

Cal Buelo- BWIG

Alpha Liu- BSAC

Date: December 13, 2011

Problem Statement:

To develop and design an animal bed system that will be able to translate in the X and Y directions, as well as angular motion. This bed system must be capable to work in micro CT, micro PET, and micro RT systems. Must design a platform for small animals that can move in the treatment area, a borehole with a diameter of 12 cm. The bed must have at least four degrees of freedom: translation on the X and Y-axes, and rotation around the X and Y-axes. The bed system should also be made to incorporate oxygen and isoflourine ducts to keep the subject unconscious. As well as a design should integrate a possible heat pad and other vital readings during the treatment like: heart rate, blood pressure, temperature, etc. In addition, shielding of the animal bed system may be required to attenuate the treatment X-rays. Our positioning system must be made with a low-density material and made so that it does interfere with the imaging systems. The specimen bed should be designed so that the specimen is positioned in the same way each time for imaging or therapy.

Client Requirements:

- Should have 4 DOF, 5 if possible: rotation about the X-axis, Y-axis, and movement in the X and Y direction, Z movement if possible
- Should have movement with 0.2mm precision up to 1 cm in X and Y
- Should have rotational movement up to 5 degree with 0.1 degree precision on both sides
- Total cost should be less than \$500

Design Requirements:

1. Physical and Operational Characteristics

- a. Performance Requirements: A mouse or similar sized animal will be lowered onto the device from above and then will be moved into the machine, along the z-axis, by a linear actuator. Our positioning system must be very precise after being put into place so the animal lies in the same position as the last test.
- b. Safety: The client's device will include an x-ray system, so we may have to come up with a shielding method.
- c. Accuracy and Reliability: Our animal positioning system must have precision in the x and y-direction of 200 microns up to 1 cm on both sides. Rotational accuracy should be .1-degree precision up to 5 degrees on both sides.

- d. Shelf Life: Will be incorporated into the client's imaging system so it will need to work many times.
- e. Operating Environment: The holding device will undergo both CT and PET scans, but the motor system will remain outside. Our device will be housed inside the client's device.
- f. Ergonomics: Qualified technicians should be using the machine with animals similar in size to a large rat or a small, skinny bunny.
- g. Size: The hole in which our bed will be inserted has a diameter of 12 cm, so our bed will be a maximum of 10 cm wide to incorporate a cm of movement along the x-axis but will be more likely 5 or 6 cm wide.
- h. Materials: We need to use a low-density but sturdy material, such as carbon fiber, for the bed as to not interfere with x-rays and stay rigid even with large loads.

2. Production Characteristics

- a. Quantity: Only one device will be needed
- b. Target Product Cost: \$500

3. Miscellaneous

a. Standards and Specifications: The device is an animal positioning system which holds specimen (mostly rats for this project) in an imaging and radiotherapy system for CT micro, PET and micro RT scanning. This positioning system has four degrees of freedom in X and Y-axes translation and angular motion about the X and Y-axes in the imaging and radiotherapy system. General specifications on the functional aspect of this device include:

- Positioning specimen in a particular way every time on the animal bed.
- Enabling the bed to translate and rotate in X and Y direction inside the imaging and radiotherapy system with specified distance (1 cm), angle (5 degrees) and precision (0.2 mm and 0.1 degree)

b. Customer: The customer mentioned that this animal positioning system is preferred to be in rectangular shape, which would fit better for a rat specimen's physical shape. In addition, the customer pointed out that among the six degrees of freedom for translation and rotation, the function of translational and rotational motion on z- axis would be the least significant and can be neglected if they causes tremendous work or delays on the whole project.

c. Patient-related concerns: The patient for our design will be a mouse or other small animal. The most important element of our design for the patient will be the oxygen, isoflourine ducts, and heating pad which will allow the patient to breathe, keep it unconscious, and keep it warm as a mouse's internal body temperature decreases when it is put under anesthesia. In addition, the patient will need to be fully supported during the scanning and treatment procedures by the stage.

d. Competition: The goal of the project is to make this technology accessible by making this small animal imaging and therapy system design open source and freely available. To do this our design must be simple to build and with precise parts; it should be less expensive than existing systems (both the entire product and our bed controller design). Examples of existing systems, which include small animal positioning systems, include:

- Siemens Inveon PET and CT scanner: commercially available product, our group will be able to see week of 9/18
- GE Triumph: commercially available PET/SPECT/CT imaging product
- SARRP (Small Animal Radiation Research Platform): Developed at Johns Hopkins and commercialized by Xstrahl, it has a robotic animal positioning system with 4 degrees of freedom (X, Y, Z, and Θ)
- X-Rad 225Cx by Precision X-Ray Inc.: has 3D computer controlled stage, makes automated stage corrections.