

Drain Tube

Team Members:

Kelsey Hoegh (BSAC), Laura Platner (Leader), Tanner Marshall (BWIG), Taylor Powers (BSAC), Danny Tighe (Communicator)

Client:

Samuel Poore, Dental and Plastic Surgery, UW School of Medicine and Public Health

Advisor:

Professor Mitch Tyler, Department of Biomedical Engineering, UW Madison

Background

- 200,000 patients diagnosed with breast cancer every year^[1]
- Must undergo mastectomy
- After mastectomy, patients wear surgical drain tube

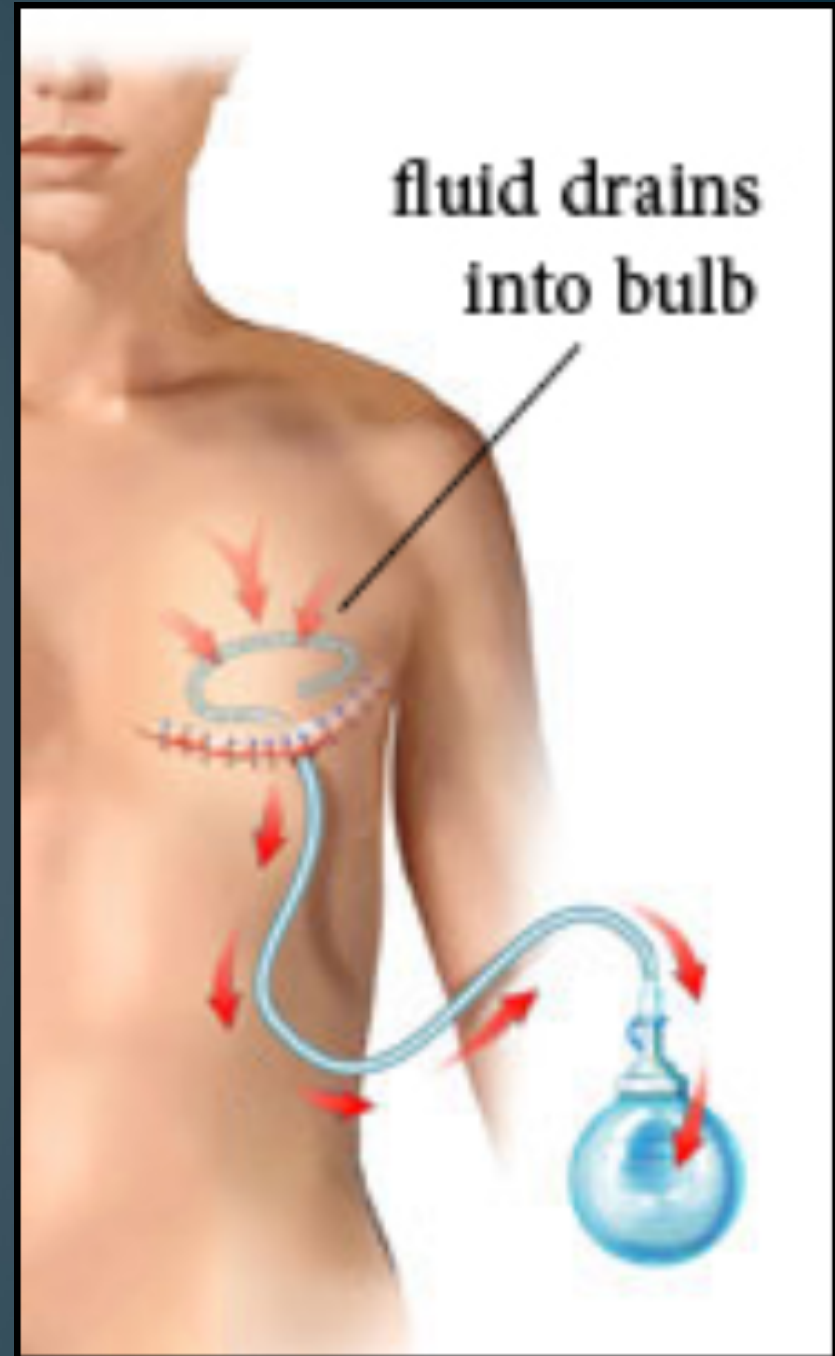

Figure 1: Diagram of a surgical drain tube. <http://www.cancer.sutterhealth.org/information/bc_notebook/postoperative_care.html>

Background

- Surgical drain tubes used to drain fluid from wound
- Drain tubes worn 14 days following mastectomy
- Patients clean and record fluid amount drained

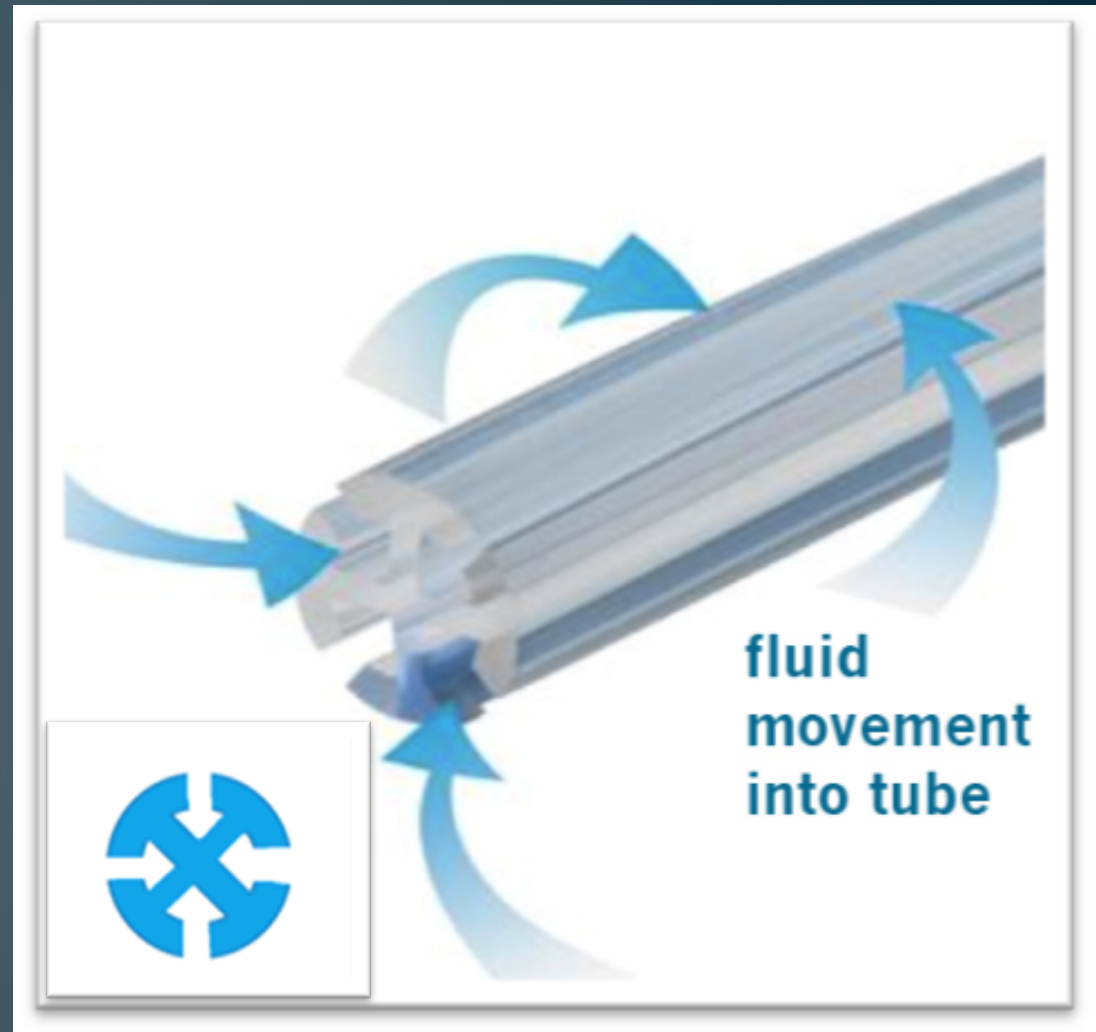

Figure 2: Close up view of a fluted drain tube.
<<http://www.ctsnet.org/peterssurgical>>

Background

- 20% of patients develop infection
- 5% get drain removed and undergo another surgery
- Extra operations = longer recovery, more complications, more medical bills



Figure 3: Skin Bacteria <<http://www.brigamandwomens.org>>

Competition

- Biopatch
 - Releases CHG up to 7 days [2]
 - Successfully fights infection
- Issues:
 - Tailored for Catheters
 - Additional work for surgeon
 - Ineffective after 7 days

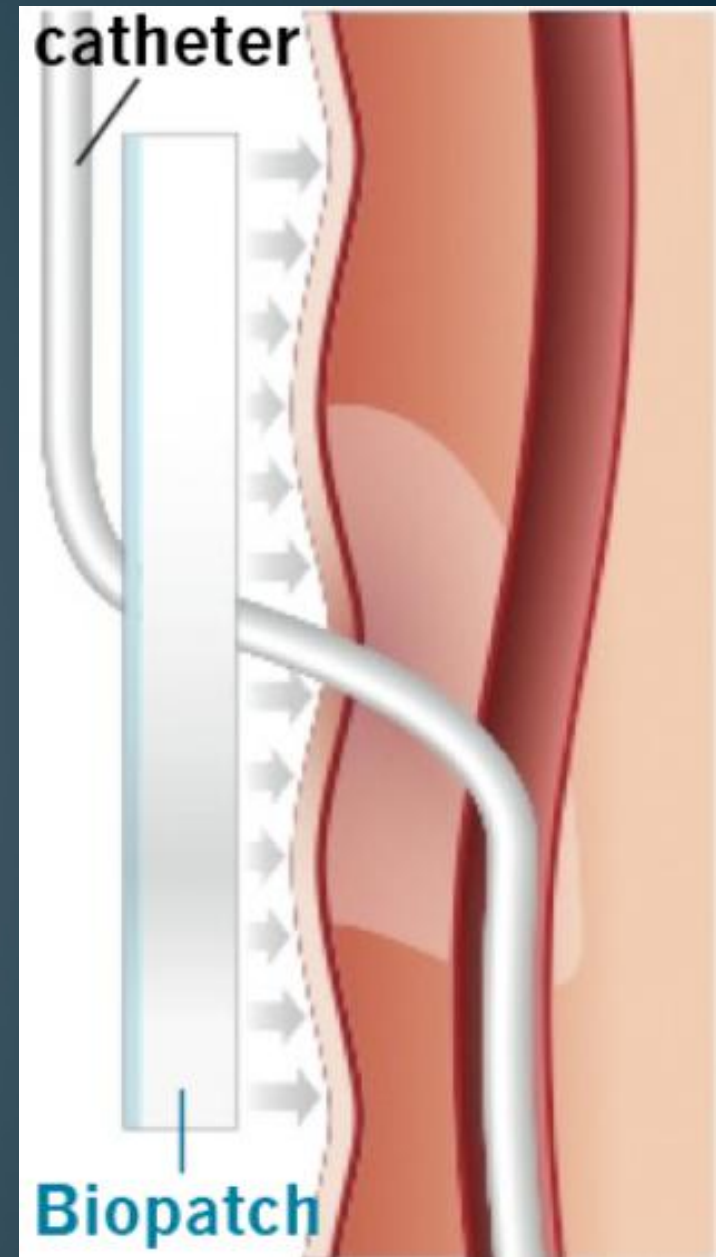

Figure 4: Diagram of a biopatch. <http://www.ethicon360.com/products/biopatch-protective-disk-chg>

Client Specifications

- Operate *in vivo* up to 2 weeks
- Small and flexible
- Integrated for drain tubes
- Reduce wound dressing needed
- Biocompatible
- Economical

General Design: Cap & Foam

- Cap made of silicone
- Suture tabs to secure drain tube
- CHG impregnated foam on the inside

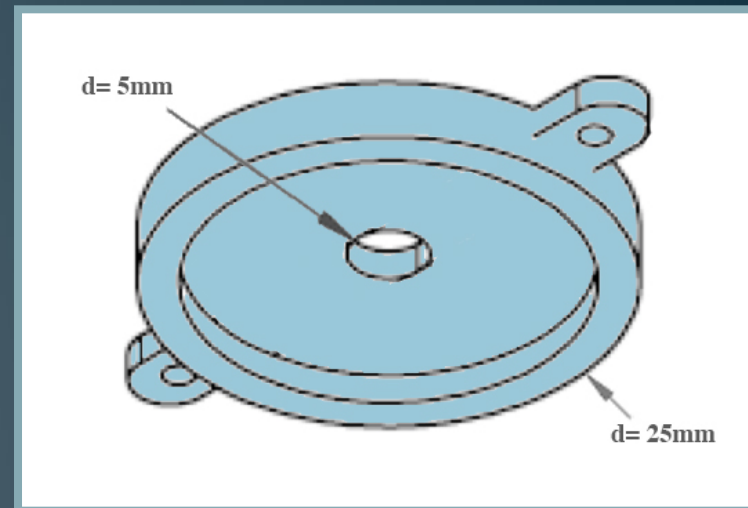

Silicone "Cap" piece

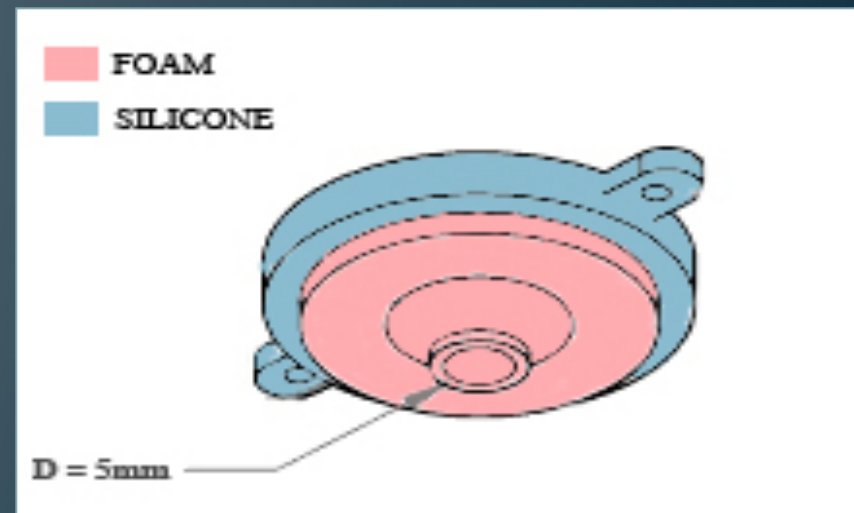

Cap piece + foam core

General Design: Cap & Foam

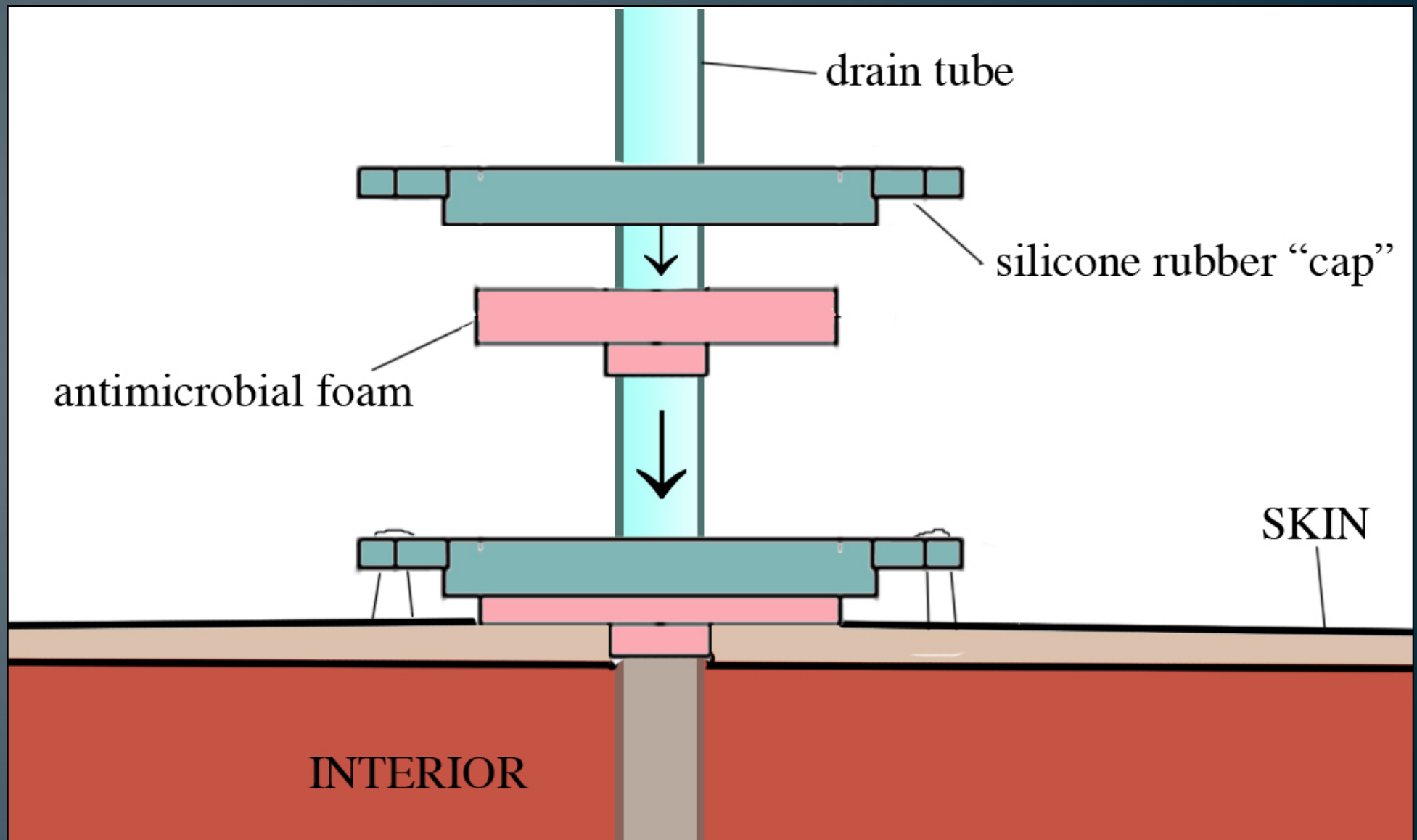

Foam Design1: Curved Core

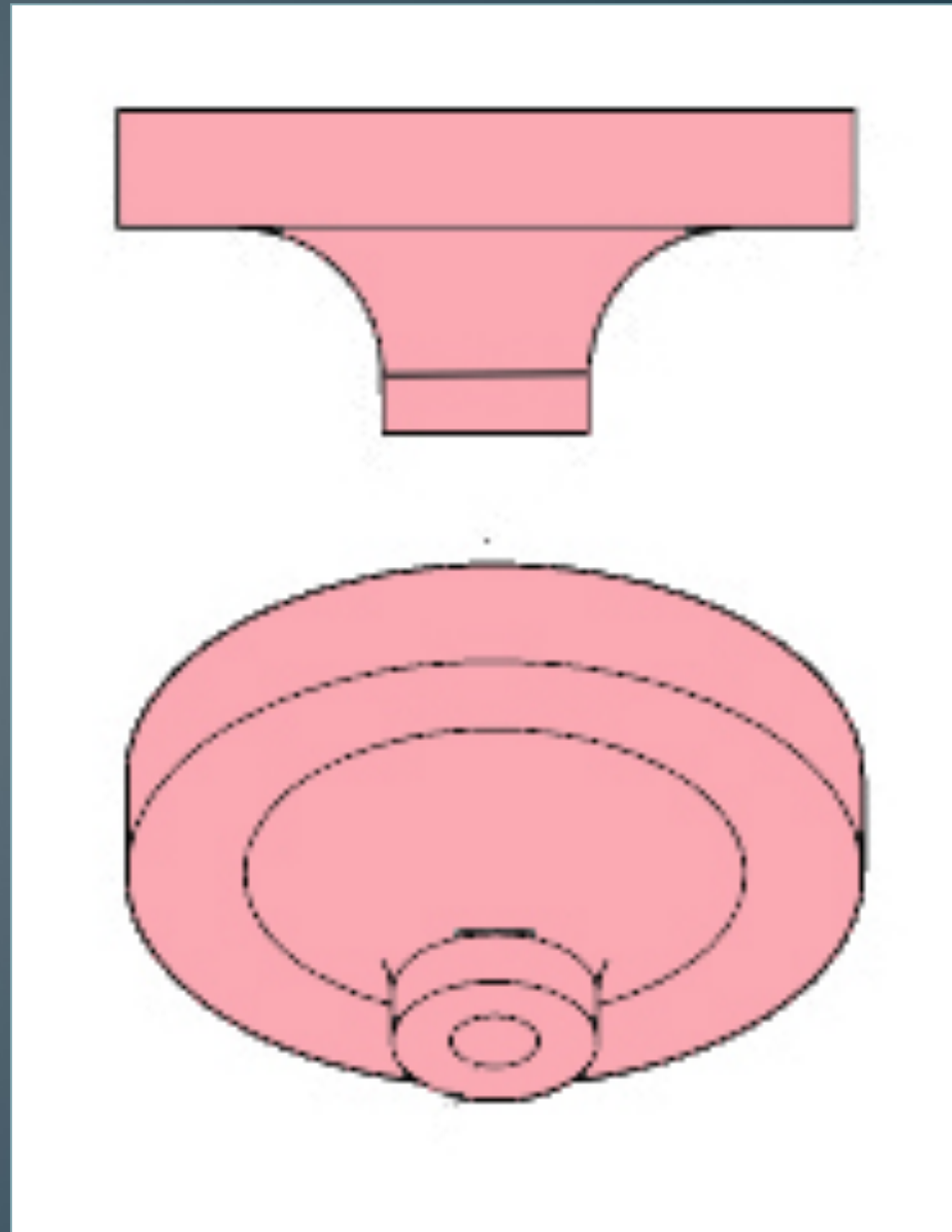

Foam Design 2: Straight Core

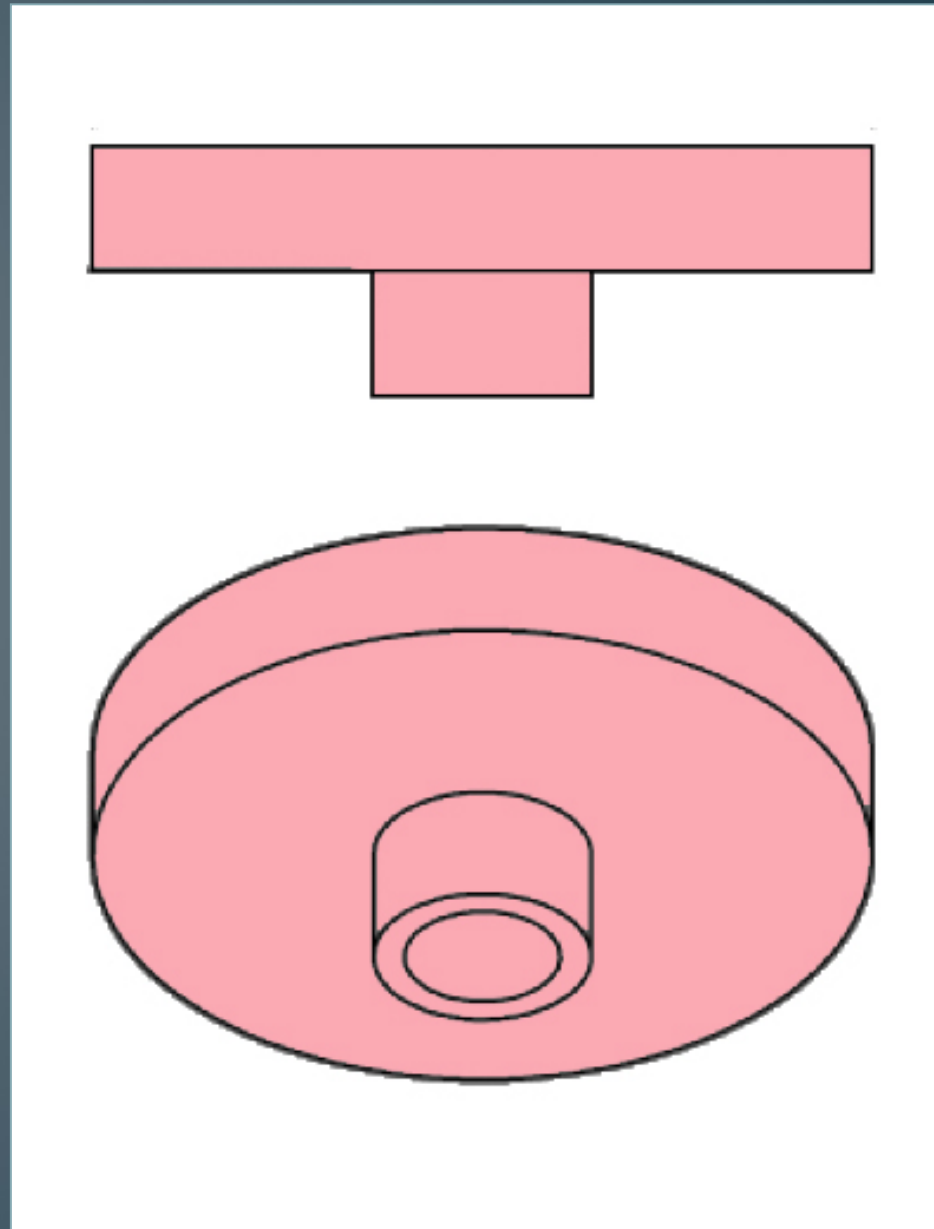

Material Design Matrix

	Weight	Cylind.	Conical
Feasibility	0.5	1	3
Cost	0.1	2	3
Durability	0.7	3	3
Safety	1	4	3
Ergonomics	0.85	3	4
Manufacturability	0.9	4	1
Total		13	11.2

Cap Design 1: Basic Silicone Cap

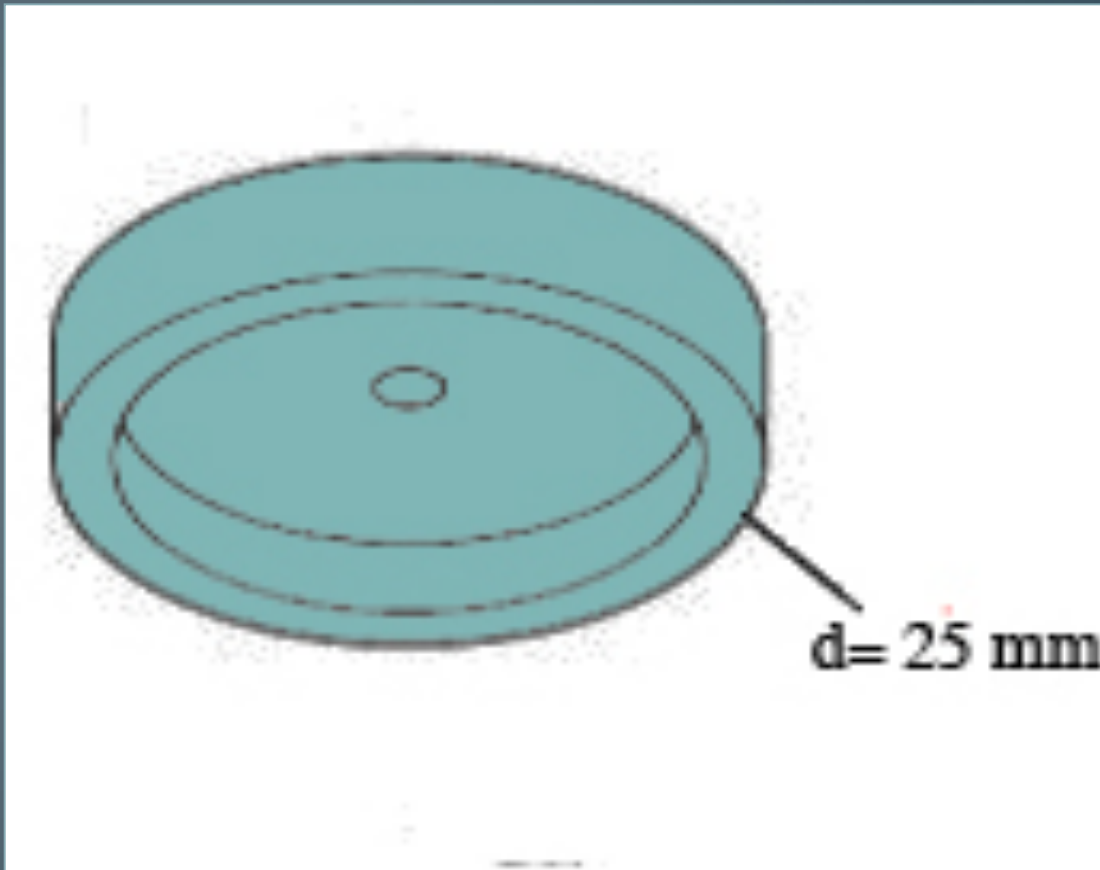

- Covers entire top of foam above skin
- Attaches directly to silicone tube
- May cause too much pressure around wound

Cap Design 2: Suture Tab

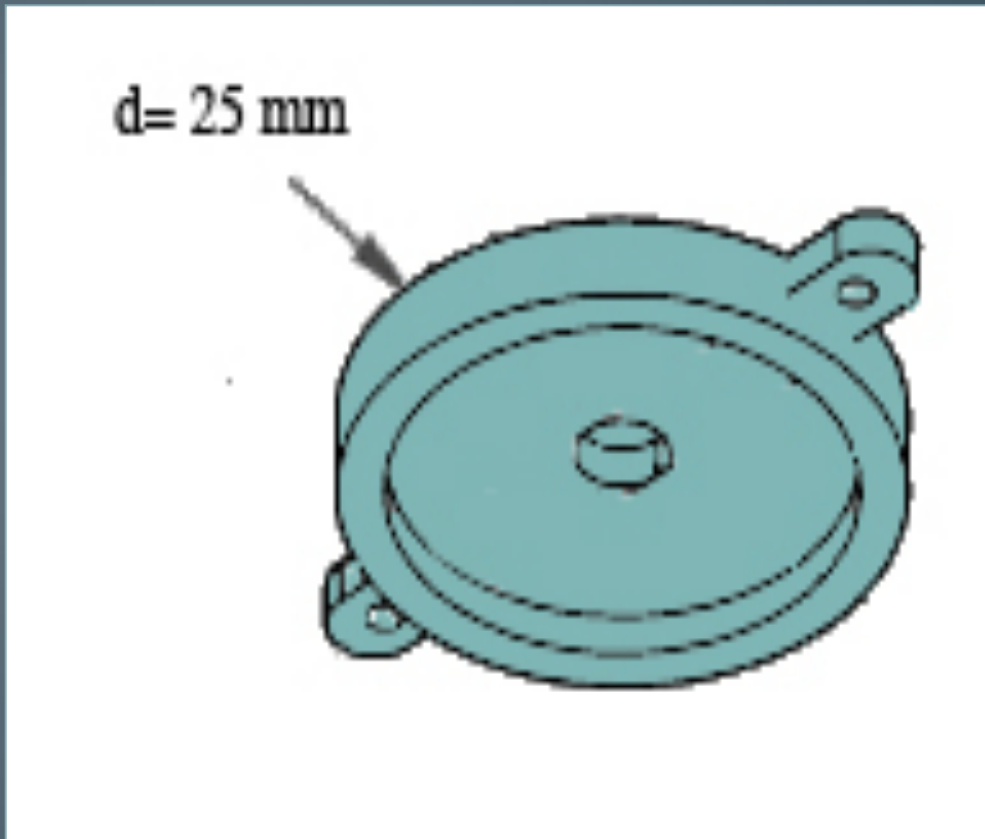

- Silicone cap that covers top of foam piece
- Suture tabs allow surgeon to keep tube in place
- Attached to drain tube
- Room between skin and cap to remove pressure

Cap Design 3: Core Tab

- Suture tabs allow surgeon to secure tube
- Silicone core would extend into the skin, not foam
- Impregnated with Silver Ions

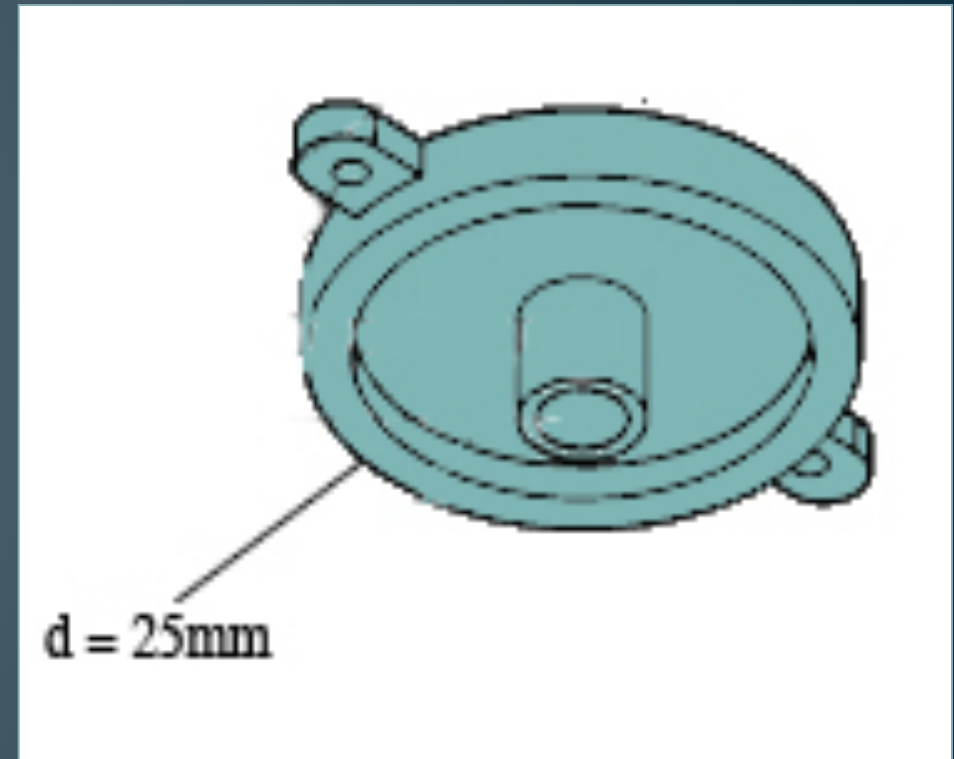

Design Matrix: Cap Design

Criteria	Weight	Cap	Suture Tab	Suture Tab +Core
Feasibility	0.8	4	3	3
Manufacturability	0.8	4	3	2
Cost	0.5	3	3	3
Safety	1	1	3	4
Durability	0.7	3	2	2
Ergonomics	0.6	1	4	4
Total		11.6	13.1	13.3

Foams For Consideration

- Testing on 4 Different materials
 - Control of each foam
 - Control with no foam
- Bacteria strain: E. Coli (non-pathogenic)
- Medium: LB agar
- Testing the zone of inhibition over 14 day period

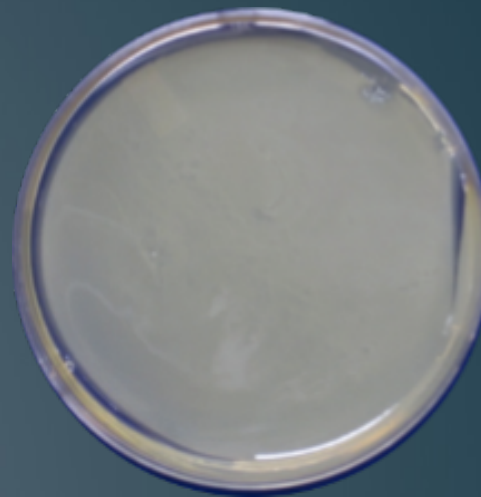

Control- E.coli

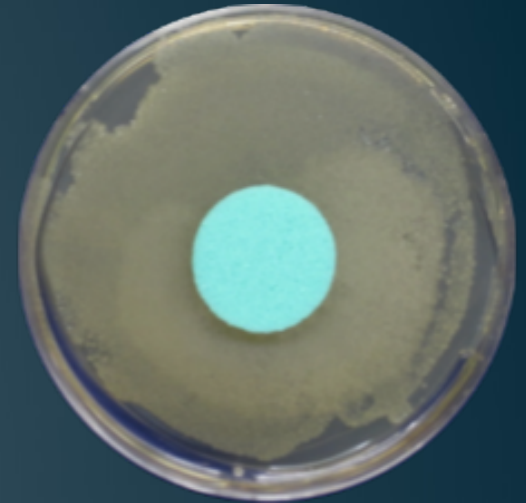

Control- E.coli + Foam

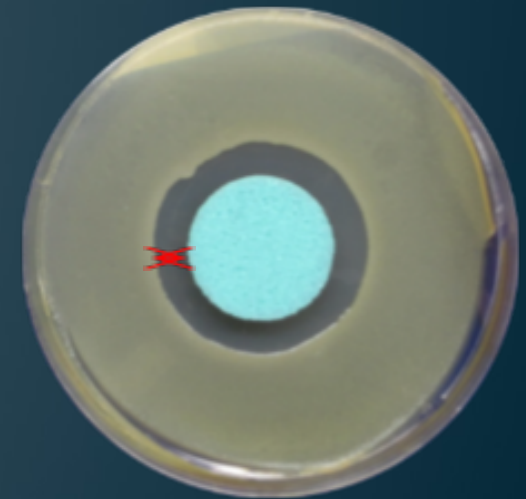
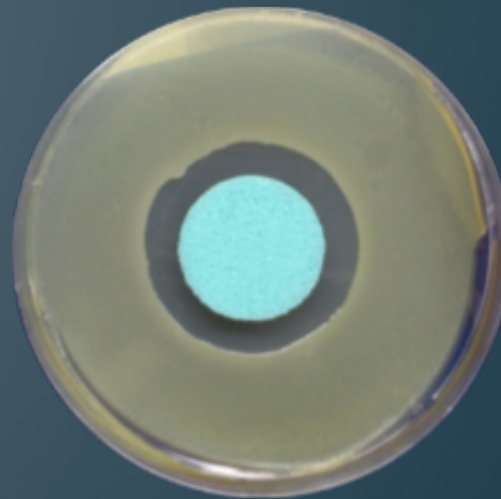

E.coli + CHG Impregnated Foam

Foam Options



Polyurethane Memory
Density: 92.9 kg/m³
Firmness 1 @ 25 %
deflection



Polyurethane Memory:
Density: 92.9 kg/m³
Firmness 4 @ 25%
deflection

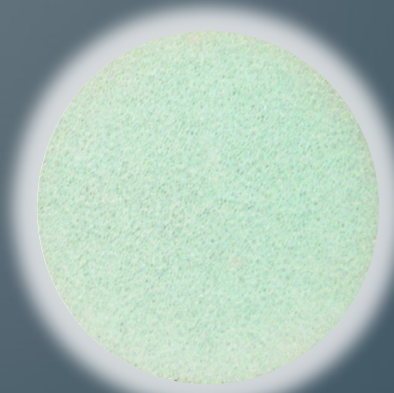

Polyurethane:
Density: 23.2 kg/m³



Polyurethane:
Density: 49.28 kg/m³

Results 1

Comparison of Average Areas of Inhibition for All Foam Types (Day1 - Day 6)

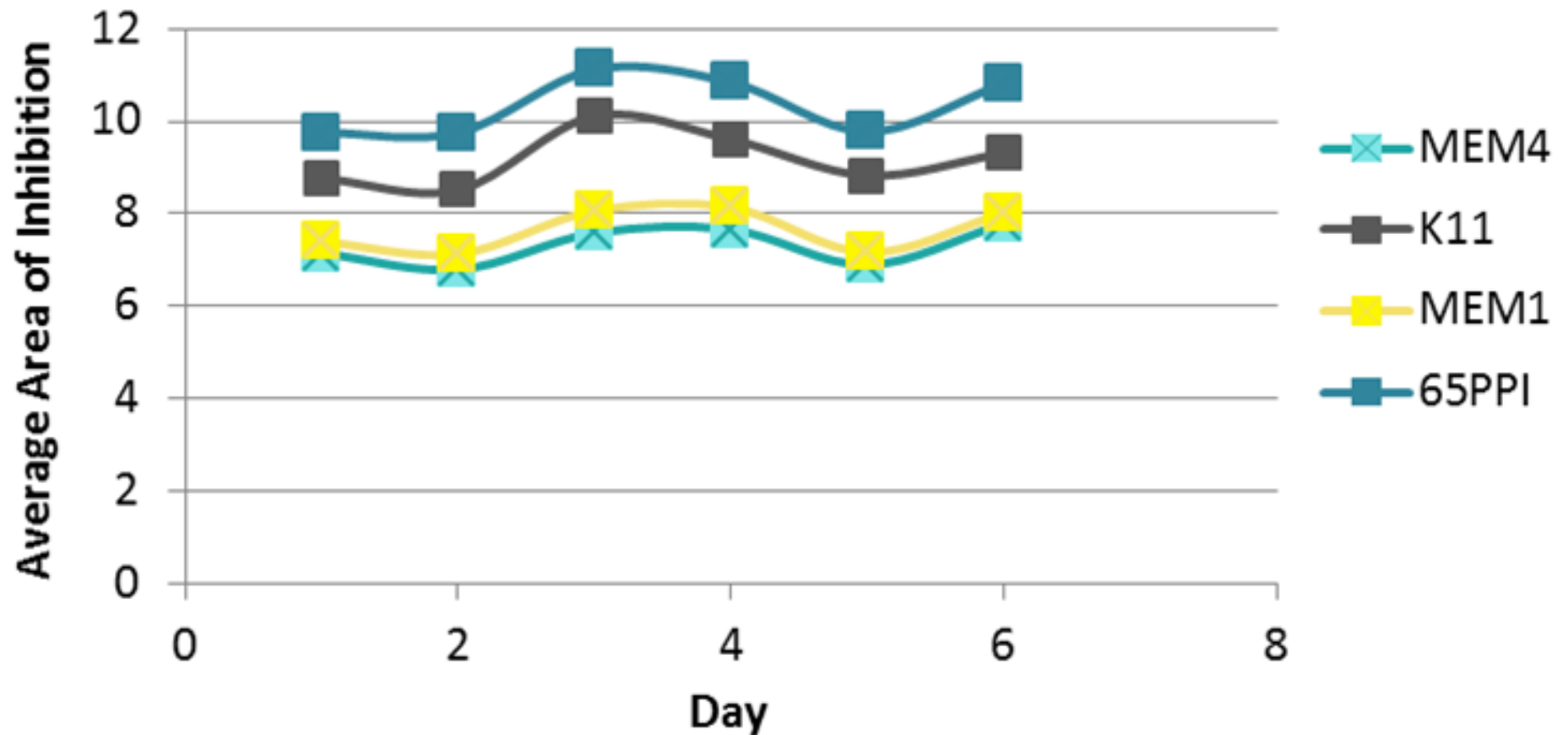

Results 2

Overall Average Areas of Inhibition for Data Days 1-6

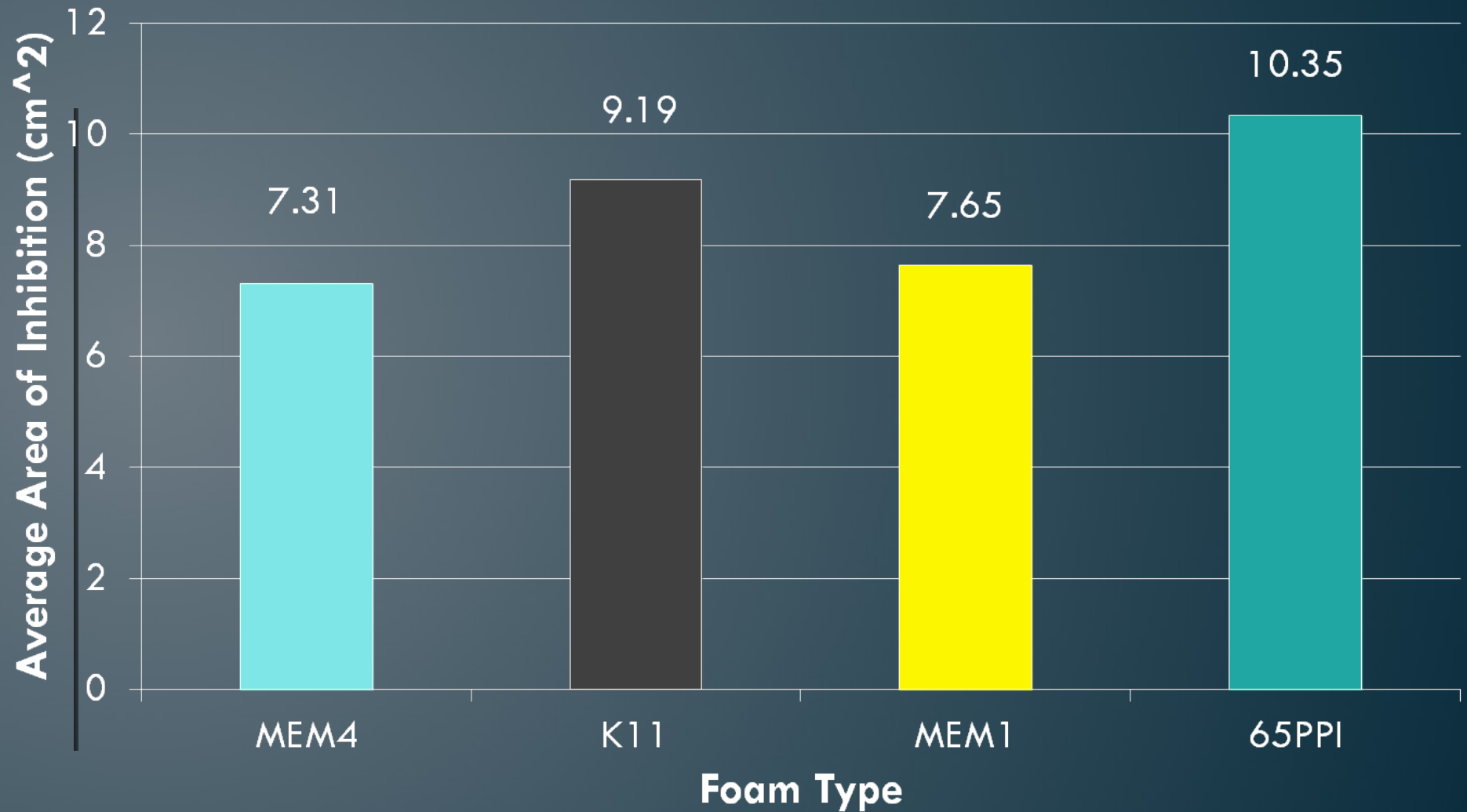

Results 3

Day	1	2	3	4	5	6
Greatest Average Area of Inhibition	65PPI	65PPI	65PPI	65PPI	65PPI	65PPI
Second Greatest Average Area of Inhibition	K11	K11	K11	K11	K11	K11
T-Test Statistic	0.1770	<u>0.0192</u>	0.1021	<u>0.0705</u>	0.1219	<u>0.0052</u>

Final Design: CidalSeal™

- Foam Disc Treated with 3% CHG Solution
 - Will fit into silicone cover / suture tab
- Silicone cover continuous with silicone drain tube
- Suture Tab makes securement easier for surgeon
- Also allows easy replacement of foam disc
- Provides protection against infection

Future Work

- Continue Collecting Data
- Start 2nd round of material testing at hospital
- Investigate application of silver ions
- Create experimental protocol for animal testing
- Create Rapid Prototype
- Fabricate Final Device