

Blinking Orbital Prosthesis

Final Report
December 14, 2011

Team Members

Sean Heyrman: Leader
Taylor Milne: Communicator
Alex LaVanway: BWIG
Mike Schmidt: BSAC

Client

Dr. Greg Gion

Advisor

Professor Thomas Yen

Abstract

Orbital prostheses have done much in restoring self-confidence for those who have lost an eye and surrounding tissue. These prostheses are specially designed to match each patient individually and create a strikingly realistic appearance. However, a notable shortcoming of this current model is that it is static, meaning the eye does not blink. This somewhat detracts from the realism of the prosthetic. As such, the objective of this project is the development of a “blinking” orbital prosthesis. Beginning where the previous semester’s design team left off, the goal is to develop a driving mechanism for the “blink” of usable size, minimal sound, and overall simplicity. Four different mechanism designs were considered, two electronically focused and two mechanically focused. Using a design matrix, the solenoid mechanism was chosen. The force required to trigger a blink was determined for with and without lubricant as well as for Teflon. This force was then used to determine a viable solenoid, which was attached to the aesthetic portion of the eye by the use of a bracket. The solenoid was connected to the cords used in the previous semester’s prototype to trigger a blink. While the prototype works well, the entire design requires much more work to become practical for use with patients.

Table of Contents

Abstract	1
Background	3
Problem Motivation	4
Current Technology	5
Stationary Orbital Prosthesis	5
Orbital Implants	6
Blinking Prototype (Previous Design Prototype)	6
Design Requirements	7
Design Alternatives.....	7
Servo Motors	7
Musical Movement	9
Automatic (self-winding) Watch Mechanism	10
Solenoid	11
Design Matrix	12
Testing	20
Force Testing	20
Cost Evaluation.....	21
Future Works	21
Separation	22
Detection	22
Powering the Device	23
Wiring	23
References	24
Appendix A: Project Design Specifications	25

Background

An orbital prosthesis is a specific type of prosthesis meant to replace the eye and surrounding tissues. It is designed to be life-like and mimic a healthy, functional eye in an effort to create the greatest extent of realism for the

patient as seen in Figure 1. The need for an orbital prosthesis is due to the loss of an eye and the surrounding tissue resulting from various eye problems. Examples of such eye problems are retinoblastoma (cancer of the



Figure 1. An orbital cavity before (Left) and after (Right) the addition of a custom orbital prosthesis. [1]

eye), end stage glaucoma, sympathetic ophthalmia (inflammation of the eye), infection, or serious injuries [2].

According to the American Academy of Ophthalmology, more than 2.5 million eye injuries occur each year, 50,000 of which result in permanent damage. Over 2.3 million people are affected by glaucoma, and several million more are subject to other disabling illnesses [3].

When one of these cases is present, a patient undergoes surgery to remove the eye and



Figure 2. An example of an ocular prosthesis, noting it is just the acrylic eye.[4]

surrounding damaged tissue. The extra tissue portion of the prosthesis is the difference between an orbital prosthesis and an ocular prosthesis, seen in Figure 2. An ocular prosthesis is the result of enucleation, or the removal of the eye, which keeps all neighboring muscles and tissues intact [2].

A great deal of artistry is involved in making orbital prostheses accurately match the patient's face, as seen in Figure 3. The eyepiece itself is often made out of a transparent thermoplastic called polymethyl methacrylate (PMMA) [5]. PMMA, commonly known as

acrylic, is highly compatible with human tissue, and after it is heated, molded, and then designed, the material superbly resembles a human eye. The acrylic eye is encased and surrounded by a

biocompatible, silicone based material that works well for imitating facial tissues. Silicone

is a common product used in orbital prostheses due to its

ability to be crafted, yet maintain a sturdy, skin-like quality. One problem with orbital prostheses is the fact that the patient is left with an inactive, artificial eye that does not move or blink.

Therefore, patients are recommended to wear glasses to help conceal their prosthesis and look straight ahead when communicating to align the prosthesis with their real eye [1].



Figure 3. Different examples of the intricate detail involved in making an orbital prosthesis. This shows how the acrylic eye fits in with the surrounding silicone material. [1]

Problem Motivation

Current orbital prostheses consist of a custom made, facial reconstruction surrounding a static eyeball-eyelid analogue. Patients who have lost an eye receive such prostheses to conceal the cavity in a way that draws less attention than other options, such as an eye patch. The effect is quite striking, as the personalized prosthesis can indeed appear entirely natural, helping the patient return to a sense of normalcy. These, however, can only go so far. Although they have an incredible resemblance to a normal looking eye, current orbital prostheses cannot move. It is this limitation that has led to the need to design a mechanism that emulates the movement of a normal eye.

A blinking orbital prosthesis is one in which the eyelid portion is connected to an apparatus that rapidly opens and closes, mimicking a life-like blink. Having this additional feature creates an even more natural appearance than the static prosthesis, where the good eye

blinks while the prosthetic remains still. Any possible way to make the replacement eye look and function like the patient's natural eye helps the individual regain confidence, which is a major part of any recovery.

Current Technology

The scope of technology related to blinking orbital prostheses is somewhat limited and not particularly advanced. Stationary orbital prostheses exist but do not provide the level of realism that would be ideal for the patient. Although orbital implants exist that will mimic eye motion, orbital prostheses are in a different category and can only be utilized under specific conditions. A prosthesis that provides a realistic, synchronized blink is not currently available. However, a blinking orbital prosthesis prototype was developed by the Fall 2010 BME design team, but is not yet at a point in development where it can be implemented.

Stationary Orbital Prosthesis

Current orbital prostheses provide a realistic rendition of the eye and surrounding tissues, seen in Figure 4. They are specially sculpted and designed individually for each patient so as to provide an ideal fit, matching shape and skin tone [1]. Despite the meticulous attention to aesthetic detail, a large degree of realism is lost when the patient blinks, as the prosthetic eye is incapable of movement and will remain stationary.

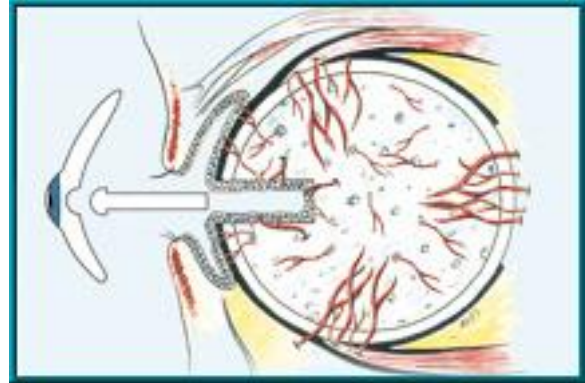

Figure 4. Patient before and after an addition of an orbital prosthesis. Note the realism of the prosthesis. [1]

Orbital Implants

Orbital implants are surgically integrated components, seen in Figure 5, which allow for the natural movement of an artificial eye. This movement is achieved through the use of the muscle remaining in the eye socket [6].

Unfortunately, this is only a viable option for those who have just had their eye removed while leaving the surrounding tissues, including the eyelid, intact.



Blinking Prototype (Previous Design Prototype)

Figure 5. Orbital implant integrating with the tissues of the eye socket. [6]

This prototype, seen in Figure 6, is able to detect and implement blinking for a silicone prosthetic eyelid. The blinking of the patients remaining eye is detected through the use of an LED/Photodiode, integrated with a pair of glasses, which would, in turn, trigger the movement of



Figure 6. Current blinking prosthesis prototype. [7]

the prosthetic eyelid [7]. Unfortunately, this design could not be utilized as is. The electrical components are still far too large to be housed inconspicuously on the patient, and the servo motor used generates a fair

amount of heat, noise, and vibration when in use.

This prototype uses an embedded cord mechanism to mimic the blinking motion. Two cords are attached to a servo motor. One cord is threaded through the lower portion of the eyelid and attached again to the servo motor. The other cord is attached to the eyelid itself such that when pulled, the eye opens. These two cords control the eyelid and create a synchronized blink

with the healthy eye. This mechanism will be used in our design as it creates a very life-like blink [7].

Design Requirements

The client requires an improvement to the current power-providing mechanism that drives the blink. The improvement should maintain the favorable characteristics of the current motor, while reducing vibration and sound. This will allow the product to be used in a patient without causing pain, discomfort, or other problems.

Since patient safety is of high concern, the product must be entirely biocompatible. For the patient's safety, the material of the external casing needs to be completely biocompatible and non-allergenic. In addition, all dangerous wires or mechanisms must be completely internal so as to not harm the patient. Given that the product is to be in contact with the human body, FDA (Food and Drug Administration) approval is also necessary, considering the orbital prosthesis is classified as a Class 1 medical device [8].

The mechanism will need to produce a realistic blink of approximately 300-400 milliseconds. As such, it should be able to pull on the two cords with enough force to create a blink. This must be able to occur for approximately 12 hours a day for an entire year with little to no maintenance. Furthermore, to prevent patient discomfort, the mechanism should also be small and lightweight.

Design Alternatives

Servo Motors

Our first design alternative is the current prototype, the servo motor. This device is very common in many toys such as RC cars and, as such, has been widely developed and is easy to

obtain. The servo motor is a precise motor that excels at starting and stopping very quickly, allowing the motor to provide enough speed for a lifelike blink. To prevent errors, a servo motor contains a feedback system, enabling it to detect its own position [9-10]. This feedback system allows the servo to spin without over-rotating, possibly causing failure in the cords, or under-rotating, causing an incomplete blink. The servo motor would be secured to the back of the prosthesis attached to the cord mechanism. The cords, which are attached at one end to the mechanical arm of the servo, and at the other end, to the eyelid, cause the eye to blink.

An advantage of the servo motor is that they typically produce a great deal of torque for their size. For example, a S3153MG Micro servo motor from Futaba is around 2.2 cm x 1.1 cm x 2.0 cm, rotates 60 degrees in 130 milliseconds, and has a torque of 1.4 kg/cm [11]. Figure 7 shows a comparison of a servo to a quarter; emphasizing the minute size[12] they can be, allowing them to easily fit into a patient's eye socket. Additionally, servos are easily controlled with a remote or signal, which allows them to mesh very well with the current detection method.

A major problem with servos is the excessive noise and vibration they create due to the gears and high rotation speed. Excessive noise can be unappealing to patients and remove the effect of a realistic prosthesis, while vibrations can cause general discomfort.



Figure 7. A comparison of a servo motor to a quarter. Servo motors can be very small and still provide relatively high torque. [12]

Musical Movement

Musical movements, as seen in Figure 8, are small, mechanical devices typically placed inside jewelry boxes designed to play a simple tune upon opening. Only the portion of the mechanism contained within the box A and with the key in circle B are of importance – the remainder of the apparatus is solely devoted to producing the tune and is therefore of no use to us.

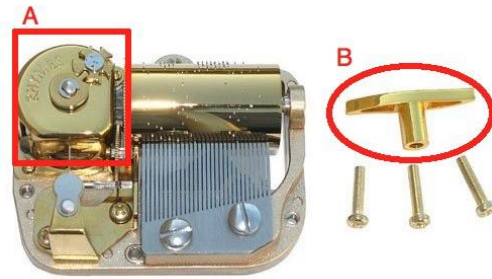

Figure 8: A typical musical movement. Box A illustrates the spring-housing while B highlights the key used to wind up the device. [13]

The device works by first attaching the key to the back of the spring-housing in box A [14]. As the name suggests, inside the casing is a coiled, spiral spring. Turning the key causes the spring to tightly wind, and upon release, will uncoil, turning a succession of gears. A small, winged gear called the governor (not clearly visible in the picture) controls the speed at which the spring uncoils [14]. If the governor is obstructed, the spring will not unwind. Thus, the spring can be fully wound and allowed to sit for an extended period of time without unwinding, if the governor is prohibited from turning.

Preliminary testing has shown that winding the spring and allowing the device to sit for as long as six days has no measurable effect on the energy stored in the spring. In other words, a fully wound mechanism that has had the governor impeded for days will play a tune for just as long as a mechanism fully wound and immediately allowed to run. This suggests that a movement could be modified such that instead of slowly uncoiling over the course of thirty seconds, the device would uncoil in tiny increments, where each increment triggers a blink in the prosthesis. Unfortunately, the device would need to be wound regularly, but a fully wound spring could potentially supply the energy necessary for many blinks over an extended period of time.

Also, the mechanism takes a moment to accelerate to full speed. This could cause a blink to be delayed. A great deal of modification would be required to correct this potential speed deficiency.

Automatic (self-winding) Watch Mechanism

Automatic, or self-winding, watches are designed to use the everyday movement of one's hand to "self-wind" the watch mechanism, rendering manual winding unnecessary. An automatic watch is powered by an internal torsional spring referred to as the mainspring. The mainspring turns various gears, which turn the hands of the watch. The movement of one's arm causes a

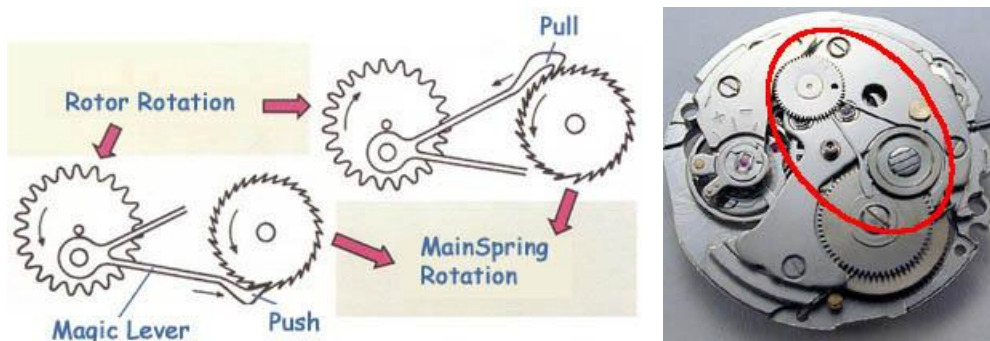

Figure 9: A diagram showing how the rotation of the rotor (clockwise or counterclockwise) pushes, or pulls, a gear which ratchets and tightens the mainspring (Left). The mechanism can be seen in a real watch (Right). [15]

rotor (eccentric weight that turns on a pivot) to ratchet a winding mechanism [15]. Modern mechanisms have two ratchets, meaning the mechanism can wind the mainspring in both clockwise and counterclockwise directions, shown in Figure 9. At full capacity, the average automatic watch can run continuously for 30-50 hours [16]. It is recommended to keep the gears moving continuously, which, assuming the patient will have their prosthesis in at all times, the everyday movement of their head would be enough to keep the watch wound completely.

The quality of watches is very dependent on the price one is willing to spend on them. Unfortunately, the smallest and most reliable watch mechanisms are part of expensive watches. The smallest watches are ideal for making the mechanism fit into an average human eye socket

but makes redesigning the mechanism for its unintended use difficult. Considering the average length of a human blink is 300 – 400 milliseconds [17], the mechanism powering the blink has to be rapid and accurate. Bearing in mind, the watch mechanism only has one second between consecutive movements, the speed the hand of the clock moves has to be less than a second. Simple observation showed the time it takes for a watches’ second hand to move is very little, and would be adequate for the speed of a blink. Another observation revealed that automatic watches are commonly associated with the “tick tock” noise of an average clock. It is not realistic for the patient to hear a “tick” inside their head every time they blink, and such a constant ticking noise could lead to headaches or additional problems.

Solenoid

A solenoid utilizes an electrical current running through a coil of wire to produce a magnetic field. This magnetic field can then be turned into mechanical motion by using ferrous metals in conjunction with the coil, as illustrated in Figure 10 [18]. Push/pull solenoids can

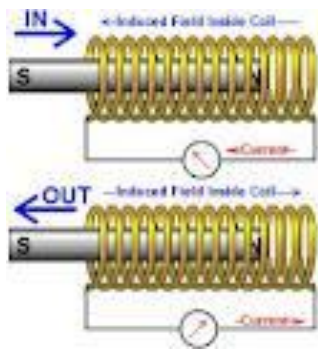

Figure 10. Wire coil produces a magnetic field which can move a ferrous plunger.[18]

specifically provide linear action [19]. This model of solenoid uses its generated magnetic field to pull the plunger into the coil, and when the current is cut, a spring returns the plunger to its original position, as seen in Figure 11. Such a solenoid would be able to provide the motion needed to drive the blinking of the orbital prosthesis. The solenoid plunger would attach to the cords connecting to the eyelid and the state of the eye (open or closed) could then be determined by

whether a current was running through the solenoid coil.

The primary concern with this design is its response time. Since the blink needs to be synced as closely as possible to the healthy eye, any delay from the time of the signal, to the movement of the plunger, could be detrimental to the function of the blinking prosthesis.

Despite this, the use of a solenoid also removes the difficulty of integrating a mechanical component with the electrical signals received to trigger the blink. The mechanical component would be directly responsive to the electrical currents with this design. Furthermore, solenoids can be made very small, with length and diameter around one-half inch, and generate a force more than sufficient for the opening and closing of the eyelid [19].

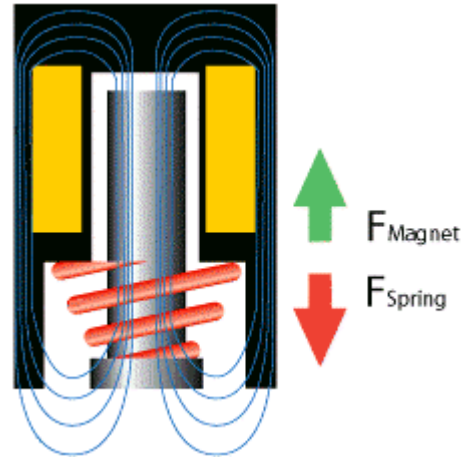

Figure 11. Basic forces in a push/pull solenoid.[19]

Design Matrix

Category	Servo	Music Box	Watch	Solenoid
Speed (30)	30	15	25	20
Sound (30)	0	30	10	25
Maintenance (20)	15	15	20	18
Ease of Production(15)	15	0	5	15
Cost (5)	4	0	3	5
Total (100)	64	60	63	83

Table 1. A design matrix showing the analysis of the four design alternatives. Solenoids received the most points across all categories.

A design matrix was used to assess which design option would be the best mechanism for the blinking orbital prosthesis. The five categories chosen were speed of the mechanism, sounds produced, maintenance, ease of production, and cost. The rankings were based on importance as discussed with the client. Safety is not included in this matrix, as it is a feature of the design that will be addressed later with a casing for the mechanism. As seen in

Table 1, solenoids have the highest ranking and were pursued for the rest of the semester.

Speed

It is important that the orbital prosthetic blinks at the same rate as the patient's good eye, therefore the speed of the mechanism was assigned a possible 30 points. Our first design alternative, servo motors, allow for very fast and accurate rotation. Therefore, the servo received a maximum speed rating of 30 points. The music box mechanism takes a moment to pick up to full speed after the stopper is released, thus this mechanism receives 15 points, much less than the servo motor. Since a typical hand of a watch or clock moves at a pointedly swift pace, the automatic watch mechanism was given 25 points. The actuation of a solenoid is sufficiently fast once in motion, but there is some concern that the delay prior to motion might be too long. This concern led to a score of 20 points.

Sound/vibration

The orbital prosthesis is going to be inserted into a patient's eye socket, meaning the mechanism will be in contact with, or very near, their inner eye. To make the prosthesis as comfortable as possible, it is ideal that the motor and mechanical aspect of the blinking mechanism is silent and does not vibrate. For this reason, sound and vibration was also assigned a possible 30 points. Since servo motors make a lot of noise and vibration, both of which can cause discomfort for the patient, the servo was given the lowest score of 0 points for this category. The music box mechanism contains a spring that when wound, will slowly uncoil to drive the gears. This spring causes no vibration and is essentially silent, thus it received 30 points. Although the watch mechanism is commonly associated with a ticking noise, it is, however, very smooth, and assuming the motor provides little to no vibration, the watch mechanism received 10 points for the lack of vibration. The solenoid generally produces little noise and vibration, but

this can vary depending on the specific model of solenoid used and the magnitude of force it is set to generate. As such it received 25 points.

Maintenance

Maintenance is always a concern when considering mechanisms with several moving parts. It is impractical to repair the mechanism on the orbital prosthesis on a daily basis, which is why maintenance was assigned a maximum of 20 points. Servo motors are widely used so there are many places that will repair a motor. Also, depending on the cost of the motor, it may be cheaper to replace the entire motor than to get it repaired. Consequently, the servo motor scored 15 points in this category. The music box mechanism would need to be wound regularly to work, and thus received 15 points. The automatic watch mechanism, on the other hand, is ideal due to the lack of maintenance required. This mechanism was given a full 20 points. Solenoids have fairly long life spans and can be replaced with relative ease when needed. A score of 18 points was given due to the potential difficulty in reincorporating the solenoid with the eyelid.

Ease of Production

Orbital prostheses are very complex and require a great deal of time to create. With the addition of a mechanism allowing the prosthesis to blink, the ease of producing the mechanism itself must be accounted for. For this reason, the overall ease of production was given a maximum of 15 points. Since the servo is just placed and attached to the two cords, there is virtually no production time for the unit. Therefore, the servo receives 15 points for this category. The music box mechanism would require a great deal of modification before it could be used for our purposes. Fabrication of small parts would likely be necessary to properly replace the superfluous portions of the original and consequently the mechanism received 0 points. The relative size of the watch mechanism and the difficulty of integrating a system to harness the

energy to make the actual blinking movement resulted in only 5 points for ease of production. Solenoids are easy to purchase in accordance to the dimensions and functions required, and as such, all 15 points were awarded in this category.

Cost

A consequence of having a complex, custom designed prosthesis is the realization that they are very expensive. With this in mind, the particular cost of the various powering mechanisms are insignificant when compared to the cost of the orbital prosthesis (approximately \$4,000) [20]. As a result, cost was assigned 5 possible points. Depending on the specific servo motor used, the cost can vary widely. They can be as cheap as \$10 or as expensive as \$1,000 depending on the quality of the servo [9, 12]. Because of this wide range, a servo motor with the correct qualities can be found somewhere in between; the servo received a rank of 4 out of 5. Similarly, music box movements have a wide price range, many of which can be purchased for less than \$20. The problem, however, is that a mechanism that delivers a higher than normal torque is required, which are far more expensive than a standard mechanism. Consequently, the music box movement received 0 points. The watch mechanism is relatively safe and reliable, and roughly \$50, resulting in 3 points for cost. The cost of an applicable solenoid falls between the approximate range of \$10-\$30. Because this is not a markedly high cost, the solenoid received all possible points in this category.

Final Design/Prototype

The prototype is composed of a prosthetic eye mounted on a specially made housing that supports the eye and contains the solenoid; this will be further expanded upon below. The eye is fitted with a silicone eyelid, seen in Figure 12, which is capable of sliding over the eye creating a “blink”. A Teflon strip is located on the leading edge of the eyelid and provides smooth

movement against the prosthetic eye. This is an improvement on the previous design as the need for lubricant is no longer necessary. This was essential because most lubricants were damaging to the prosthesis itself, or evaporated within minutes [20].

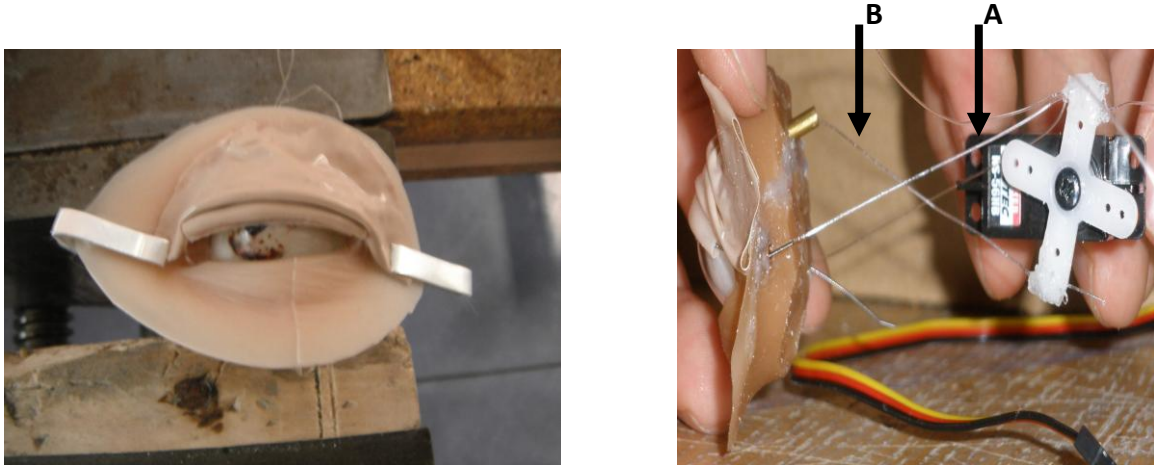

Figure 12. The current prototype (Left) and the cords that trigger the blink (Right). When pulled, cord A closes the eye while cord B opens the eye. [7]

The previous semester's blinking mechanism is maintained as two sets of fishing line are used to create a blink. The line threaded through the edge of the eye lid (cord A in Figure 12 above) and into the prosthetic at the corners of the eye is responsible for eye closure. When both ends of this cord are pulled, the eyelid is forced down across the eye, "shutting" the eye. The eyelid is brought up to its initial position by the second line (cord B), which is located on the peak of the eyelid arch and runs beneath the eyelid into the prosthetic. When this line is pulled the eyelid is raised, "opening" the eye.

These cords are pulled or relaxed by the activation or inactivation of a push/pull LEDEX solenoid operating at approximately 12 V, the solenoid used is shown in Figure 13. The solenoid has a diameter of 1.122", width of 0.580", and peg length of 1.417". When activated by a current, the solenoid peg is extended, exerting force of up to 53.4 N, and leading to the closure of the eye by pulling the line that runs through the leading edge of the eyelid taught [18]. When the current

running through the solenoid is cut the peg returns to its resting position inside the solenoid due to gravity. This releases the tension on the line that induces shutting and pulls the line that runs underneath the eyelid, opening the eye.



Figure 13. The solenoid used in the design. Runs at a 50% duty cycle with 12 V 1 A current.

The solenoid is triggered by a signal from an Arduino through a circuit designed to protect the Arduino and to provide enough power to the solenoid. This was accomplished through the use of a 12 V, 1 A power source, a mosfet, and a diode. The power source was chosen based on the rating of the solenoid as the rest of the circuit does not draw very much voltage. A mosfet was used in place of a transistor because mosfets typically have lower voltage drops across them than a traditional transistor. The gate of the mosfet was attached to the Arduino, which provides a 5 V signal when a blink is detected. This signal then completes the circuit containing the solenoid, causing it to actuate a blink. The diode was placed in parallel with the solenoid to prevent backflow for current that could damage the Arduino [21]. The circuit design is seen below in Figure 14.

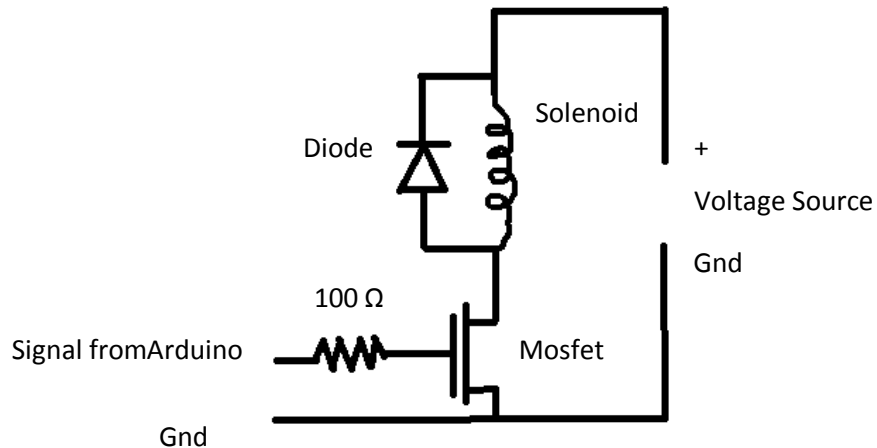

Figure 14. The circuit built to allow the Arduino to signal the solenoid. It includes a diode to reduce backflow of current and a mosfet to control the solenoid.

One of the benefits of this design is the smooth transition from electrical signal to mechanical movement provided by the solenoid. This eliminates the need for various mechanical intermediates that take up more space and make available greater opportunity for malfunction or misalignment. Also, the life of a solenoid is considerable, and would rarely need to be replaced.

The primary difficulty associated with the use of a solenoid is the response time. For the blink to be capable of realistically mimicking an actual blink, it must be able to respond between 300-400 ms, the average speed of a human blink [20]. However, this can be achieved with the appropriate solenoid model which could be custom made to exact specifications. Thus in terms of a final product, this is not a concern.

An additional benefit of the modifications made with this design is the elimination of the need for lubricant. The use of Teflon beneath the eyelid allows for easy movement of the eyelid over the eye, shown in Figure 15. This is beneficial as the user no longer has to spend time

lubricating the eye. Additionally, the elimination of a lubricant slows the degradation of the eyelid silicone, giving a longer lifespan to the prosthetic.

The solenoid is contained in a housing that allows the solenoid to be mounted to ensure the solenoid does not move and maintains the correct orientation to create a blink. The bracket also allows

for the aesthetic portion to be mounted providing a stable eyepiece. A rotating lock mechanism allows for easy insertion and removal of the solenoid while still providing a stop for the solenoid pin. This bracket was designed using SolidWorks and later created using a 3D printer. The Solidworks bracket can be seen in Figure 16.



Figure 15. The eyelid with the strip of Teflon. The Teflon dramatically reduces the necessary force to move the eyelid.

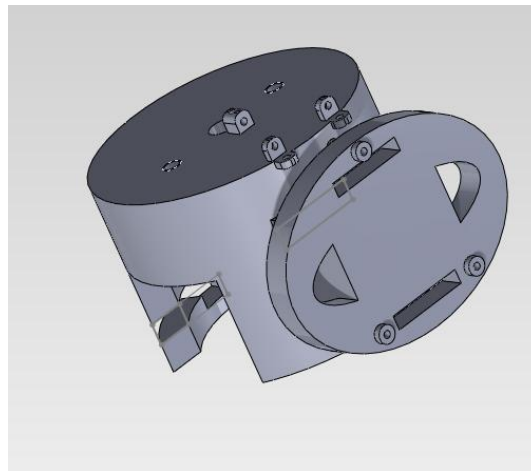

Figure 16. The bracket design, which includes holes to place the wires through, and also mounting area for both the solenoid and the prosthesis.

Testing

Force Testing

In order to determine which solenoid is necessary for the design, the required force to create a blink must be determined. Since two cords create a blink, each one must be analyzed separately. This is accomplished by attaching the cords to a small scale while the prosthesis is clamped to a table; this set up is shown in Figure 17. The scale was then pulled to create a blink. The speed of the pull was very important as a smaller force could create a blink albeit an unrealistic blink. Currently, the testing was done by hand leading to some error in blink speed.



Figure 17. Force testing set-up. The prosthesis was placed in a vice and the force meter was attached to the cords and pulled to create tension on the cords.

However, the data from the test was very conclusive. To produce a realistic blink required a force of around 1.5 N when well lubricated. Without lubrication, the force to blink was roughly three times greater for opening the eye. The specific scale that was used during testing was not large enough for closing the eye without lubrication. Due to the orientation of the embedded cord mechanism, the largest forces are those required to close the eye. Teflon allowed the eye to glide very easily across the surface, resulting in force values similar to that of a lubricated eye. The results from the test can be seen in Table 2.

	Without Lubricant (N=3)	With Lubricant (n=3)	With Teflon (N=10)
Opening	≈1.53 (± 0.04) N	0.23 (± 0.06) N	0.19 (± 0.02) N
Closing	>>1.4710 N	0.5 (± 0.2) N	0.87 (± 0.07) N

Table 2. Data determining the force required for a blink. Closing the eye was much more difficult than opening. Also, lubrication helps decrease the force required by around one third.

Cost Evaluation

The overall cost of the project was fairly low at \$101.90. However, a majority of this cost was purchasing a single solenoid, which would decrease if purchased in bulk. The cost of other parts, such as the power adapter and Teflon was minimal in the scope of the project. Since a typical prosthesis can cost up to \$5,000, the cost of the solenoid and other parts do not impact the overall cost of the prosthesis very much [20]. The cost of the individual parts can be seen in Table 3 below.

Item	Cost
Teflon	13.23
AC adapter	15.98
Solenoid	72.69
Total	\$101.90

Table 3. The overall cost of the design. A majority of this cost was associated with the solenoid.

Future Works

The prototype we were given at the start of the semester was one that could blink after receiving a signal from an infrared LED sensor. The blink was powered by a small, unrealistic servo motor, due to the heat, sound, and vibration accompanying it. The design allows for a

reduction in overall size of the eye, and elimination of sound and vibration using a minute push/pull solenoid. However, many improvements still would need to be made.

Separation

The current design is a single piece with all of the components largely fixed in place. This poses the problem that our client would be responsible for producing the entire prosthesis, mechanism included, for each patient. Ideally, the design could be modified in the future such that the device would consist of two “halves” representing the aesthetic and mechanical portions of the prosthesis. The aesthetic, or “front” half, would be composed of the acrylic eye and surrounding tissue, including the moving eyelid. The mechanical, or “back” half, would contain the solenoid that drives the device. The front and back halves could be joined by an interlocking male-female gear mechanism. This improvement would allow the back half to be a standard, mass-produced part, meaning that our client could purchase these prefabricated and only be responsible for creating the custom aesthetic front half for each individual patient. Additionally, this would allow for easier cleaning and maintenance of the device.

Detection

Although the current infrared LED and photodiode design from the previous design team can successfully detect a blink, the system is not without problems, especially with accuracy. The sensor often registers false blinks and occasionally blinks repeatedly until it is turned off. A combination of a more sensitive photodiode, and possibly altering the Arduino coding, could potentially correct these errors. Additionally, we would like to be able to nest the IR LED and photodiode within the frames of the glasses and use the arms of the frame to conceal the wires.

Powering the Device

The current prototype is powered by an AC adapter that is plugged into a wall. Ideally, the blinking orbital prosthesis would be battery powered, thereby allowing the patient to escape the confines of a power source. The battery would be small enough to fit inside the patient's eye socket, produce no heat or harmful currents, and provide enough power to actuate the solenoid and power the blink. Currently, scientists have already developed high-powered nanobatteries (60,000 times smaller than a typical AAA battery) [22]. If there was a way to incorporate a nanobattery into the mechanism, it would eliminate the need for an outlet and the orbital prosthesis would be powered on the go.

Wiring

Along with power issues, the next issue that would need to be addressed is the cord mechanism. Currently, there is an excessive amount of wires connecting the LED sensor on the glasses, to the orbital prosthesis. This is very impractical and, ideally, every wire involved would be hidden from the outside world. A wireless signal from the photodiode to the eye would be the best choice, but such technology is not yet accessible. Combining the mess of wires into one, smaller wire that ran down the length of the glasses and blended in with the patient's skin and hair, the sensor could connect with the orbital prosthesis and be as aesthetically pleasing as possible.

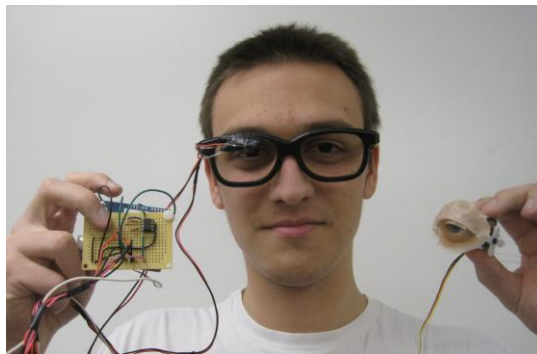

Figure 18. The current wiring that allows the eye to be used. Many wires remain visible, detracting from the effect of the prosthesis.[7]

References

- [1] A. V. Gregory Gion. *The Medical Art Prosthetics Clinic - Orbital Prosthesis*. Available: <http://www.medicalartprosthetics.com/content.php?page=prostheses&sec=orbital>
- [2] T. S. f. t. B. a. V. Impaired. *Enucleation*. Available: <http://192.188.148.10/Education/anomalies/enucleation.htm>
- [3] A. A. o. Ophthalmology, "Eye Health Statistics at a Glance," American Academy of Ophthalmology 2009.
- [4] *Prosthetic Eye Picture*. Available: <http://upload.wikimedia.org/wikipedia/commons/b/bc/ScleralLens1.jpg>
- [5] e. a. Eugene P. Goldberg, "Biofunctional Surface Modified Ocular Implants, Surgical Instruments, Medical Devices, Prostheses, Contact Lenses and the Like," US Patent 6387379 B1, May 14, 2002, 2002.
- [6] B.-E. O. Implants. *Orbital implants and artificial eyes*. Available: <http://www.ioi.com/patient/implants.html#>
- [7] J. G. Justin Cacciatore, Mike Konrath, Blake Marzella, Michael Musser, "Blinking Orbital Prosthesis," 2010.
- [8] FDA. (2011, FDA. Available: <http://www.fda.gov/>
- [9] N. Instruments. *AKM Brushless Servo Motors*. Available: <http://sine.ni.com/nips/cds/view/p/lang/en/nid/209133>
- [10] E. Motors. (2011, *Stepper Motors*. Available: http://www.electricmotors.machinedesign.com/guiEdits/Content/bdeee4a/bdeee4a_2.aspx
- [11] Futaba. *Digital Servos*. Available: <http://www.futaba-rc.com/servos/digital.html>
- [12] P. R. a. Electronics. *Sub-Micro Servo 3.7g (Generic)*. Available: <http://www.pololu.com/catalog/product/1053>
- [13] Amazon.com. *Musical Movement With Beautiful Sound Quality Plays "Blue Danube Waltz"*. Available: http://www.amazon.com/gp/product/images/B0006BCF92/ref=dp_image_0?ie=UTF8&n=2617941011&s=arts-crafts
- [14] M. B. Attic. (2011, *Learn About Music Boxes*. Available: <http://www.musicboxattic.com/leabmubo.html>
- [15] Horologyzone. *Basic Knowledge*. Available: <http://horologyzone.com/watch/watch-school/watch-history.html>
- [16] I. Crowley. (2006, *Quartz vs Mechanical*. Available: http://www.mailboxcentres.com/Quartz_vs_Mechanical.html
- [17] S. LaFe, " Eye-tracking reveals not just what you're looking at, but how hard you're thinking about it," in *The San Diego Union - Tribune*, ed. San Diego, 2007.
- [18] Ledex, "Introduction to Solenoids / Basics of a Solenoid."
- [19] J. Electric. *Solenoids*. Available: <http://www.solenoids.com/>
- [20] G. Gion, "Client Meeting," ed, 2011.
- [21] P. M. Morrow, "Meeting for Circuitry," ed. Madison, WI, 2011.
- [22] E. Smalley, "World's smallest battery will put power everywhere," in *Cnet.com*, August 2, 2011 ed, 2011.

Appendix A: Project Design Specifications

Blinking Orbital Prosthesis

Product Design Specifications

December 14, 2011

Team Members: Sean Heyrman, Taylor Milne, Alex LaVanway, Michael Schmidt

Advisor: Thomas Yen

Summary: Orbital prostheses are removable silicone restorations of the eyeball, the lids, and surrounding tissues. Current prostheses match the unaffected eye in a normal gaze but have no life-like movement. Adding life-like movement to the eye would greatly help boost the patients confidence. Advances have already been made by previous UW students toward creating a blinking mechanism. The goal of this project is to develop a design that maintains the favorable aspects of current prostheses: lightweight, small, and durable; but also incorporates a blinking mechanism that is synchronized with the other eye.

Client requirements:

- The designed mechanism must have less noise and vibration compared to the last group's prototype.
- The designed mechanism must be small enough to fit into the eye socket.
- The design should be easy and quick to fix/maintain.
- The design should be able to create a lifelike blink (300-400 milliseconds per blink).

Design requirements:

1. Physical and Operational Characteristics

- a. *Performance requirements:* The device must be able to handle at least 12 hours a day for an entire year.
- b. *Safety:* Since the mechanism needs to be inside the eye socket, everything needs to be encased in a biocompatible material.
- c. *Accuracy and Reliability:* The mechanism must be able to power a blink at a realistic speed, which is around 300-400 milliseconds. It also must blink every time the other eye blinks to keep the look consistent with a realistic blink.

d. *Life in Service*: The mechanism should be maintained on a yearly basis. The device will be used daily for at least 12 hours a day. Also any necessary power source must be easily replaced/recharged.

e. *Shelf Life*: The shelf life of individual components should be around 1 year.

f. *Operating Environment*: The device will be located in a patients eye socket and will need to be able to withstand those conditions. It also must be able to work correctly during normal activities.

g. *Ergonomics*: The device must be easily useable. This includes lubrication (if necessary), insertion into the eye socket, recharging, and, if necessary, sterilized.

h. *Size*: The device should be able to fit into the eye socket.

i. *Weight*: The device should be light enough to not affect the patient during normal use.

j. *Materials*: All materials in possible contact with the patient needs to be biocompatible and non-allergenic.

k. *Aesthetics, Appearance, and Finish*: The mechanism should be able to create a realistic looking blink.

2. Production Characteristics

a. *Quantity*: The quantity will be 1 mechanism per prosthetic eye.

b. *Target Product Cost*: The budget for the prototype is \$1000.

3. Miscellaneous

a. *Standards and Specifications*: FDA class 1 approval is required for orbital prosthetics. The mechanism should be able to fit into class 1 as well.

b. *Customer*: The product should be easy to affix to the aesthetic portion of the prosthetic eye and be easy to repair.

c. *Patient-related concerns*: The device must work properly in creating a timely blink. Also, the device needs to be quiet and produce minimal vibrations.

d. *Competition*: Currently orbital prosthetics that are currently publicly available do not have a blinking mechanism.