

Cleaning Indicator for Reusable Medical Equipment

Kevin McConnell – Team Leader

Paul Strand – Team Leader

David Hintz – Team Communicator

Matt Boyer – BSAC

Ross Paulson – BWIG

Advisor: Professor Chris Brace

Outline

- Problem Statement
- Background Information
- Design Specifications
- Design Alternatives
- Design Matrix
- Future Work

Problem Statement

- Clients: Dr. Scott Springman, Christina Jordan
- Develop an indicator for reusable medical equipment
- Equipment starts in OR
- Moved out if not used
- Limited number of machines
- Located and moved when not in use
- Often not moved to reprocessing room

Background Information

Machines Used



Bronchoscope →



← Glidescope

Machines Used



Reprocessing

- Machines used repeatedly-sterilization is crucial
- Used carts brought to reprocessing room
- Sterilization Techniques
 - Autoclave
 - Chemical wipe down (QUAT)
- Entire Cart Reprocessed

Current Method

- Flip sign on chain
- Problem:
 - Falls off
 - Flipped inadvertently
 - People forget to flip



Product Design Specifications

- Device must:
 - Not interfere with functionality of equipment
 - Be capable of withstanding cleaning from quaternary amines
 - Be capable of withstanding autoclave environments
 - (250° F and 20-30 psi)
 - Be approximately 3"x 1.25"x 1.25"
 - Not be biologically hazardous
 - Be permanent

Flipper Mechanism

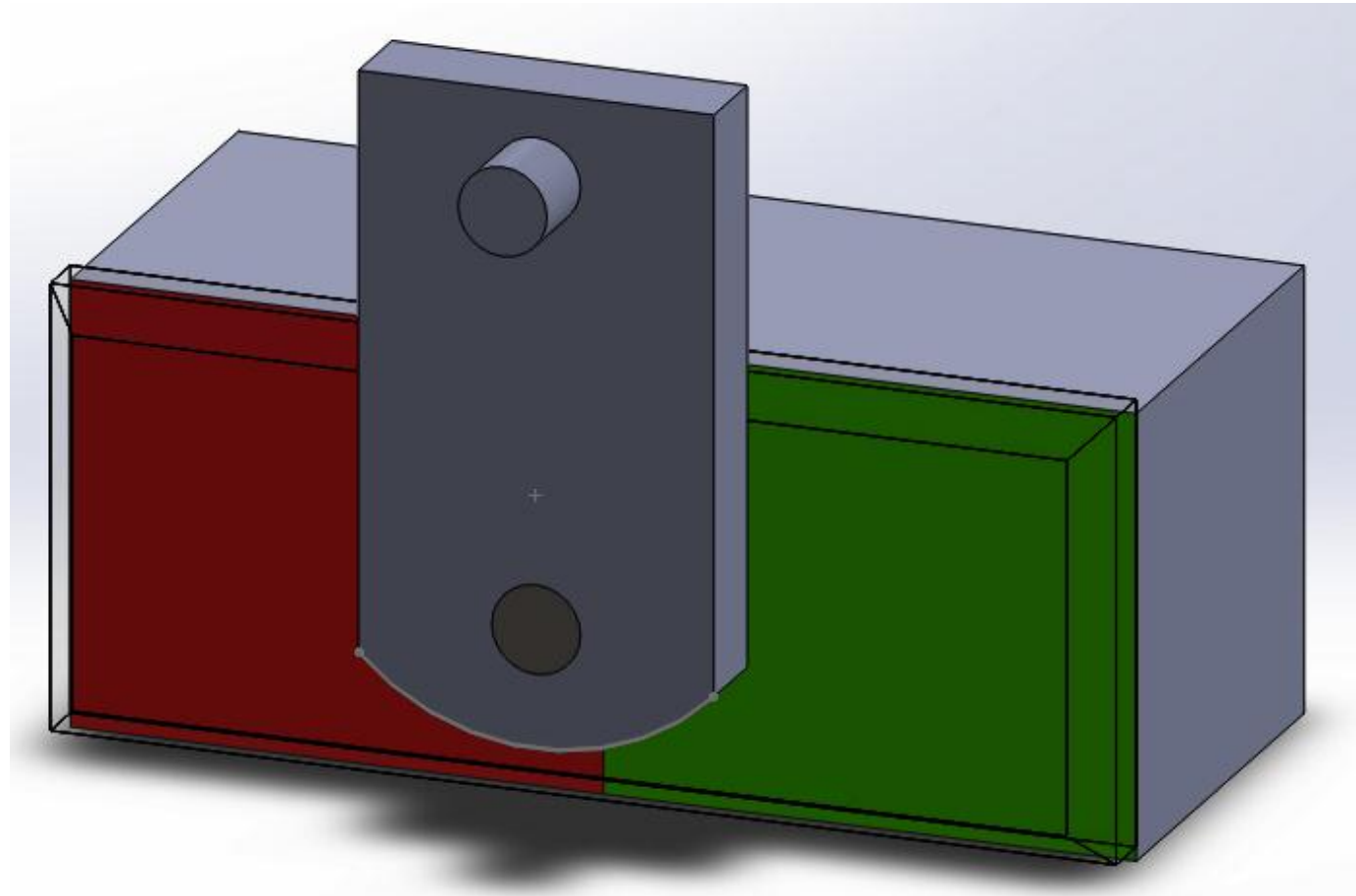

Knob 1 Mechanism (Side)

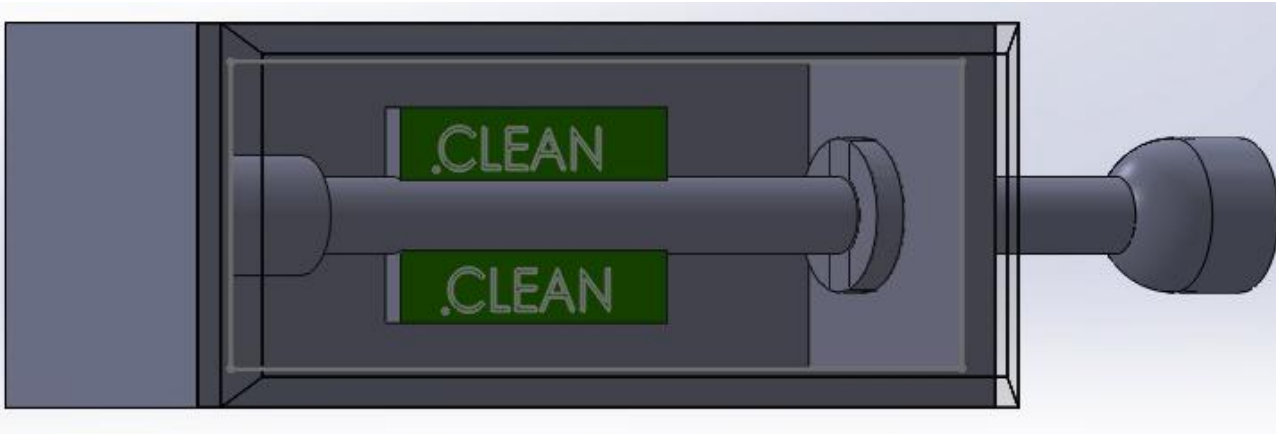

Gear Example

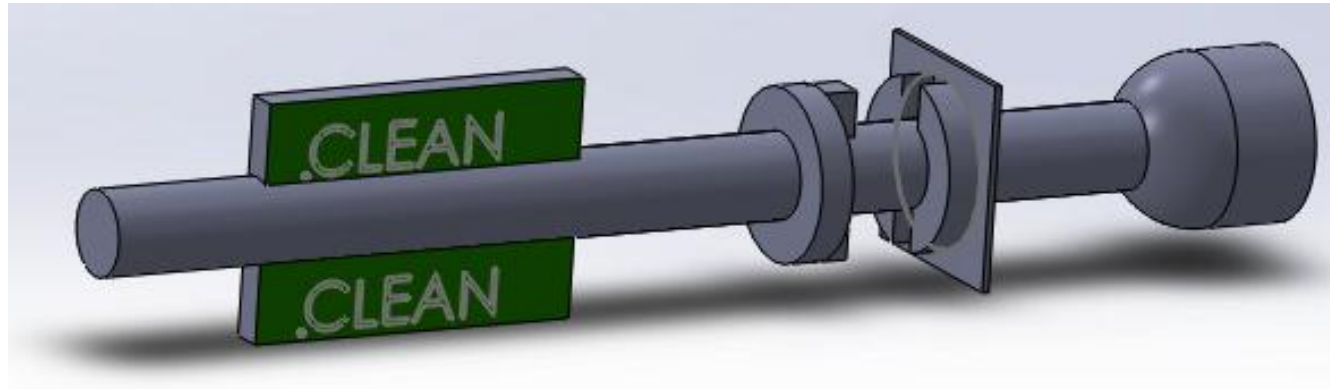

Knob 2 Mechanism (Front)

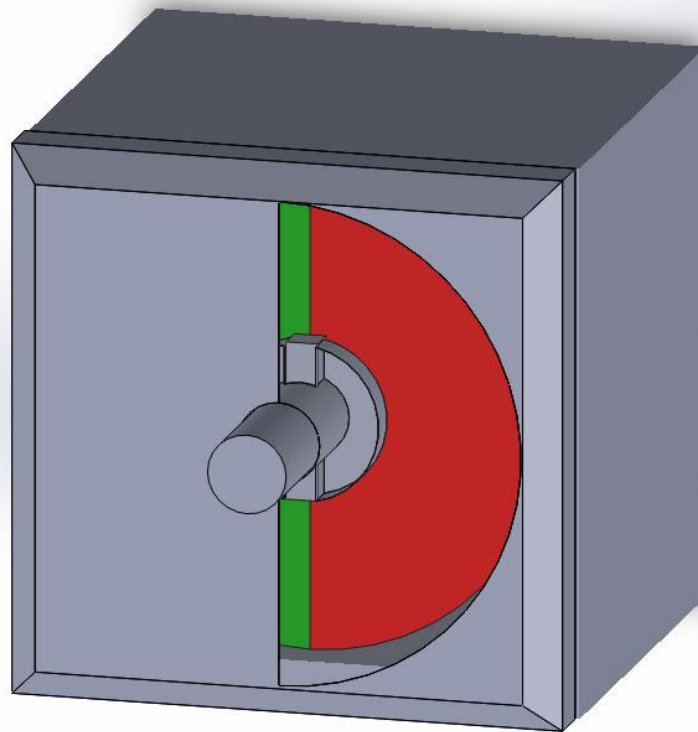

Design Matrix

Metric	Weight (1-3)	Flipper	Knob 1 (Side)	Knob 2 (Front)
Indication Reliability	3	2	5	4
Ease of Use	2	5	4	4
Cleaning Accessibility	3	1	5	5
Durability	1	1	5	3
Longevity	2	5	4	4
Size	1	5	3	4
Cost	1	5	3	4
Total		40	57	54

Future Work

Future Work

- 3D Printing
 - 10/1000ths precision
 - Saddle Joint gear mechanism
 - WID or ECB printer
- User Feedback
 - Collect user critique
 - Adjust prototype

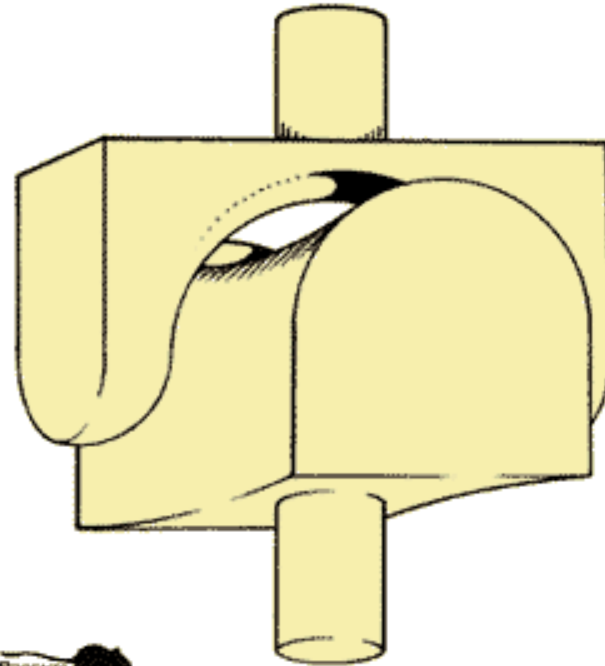

<http://www.heumann.org/body.of.knowledge/a8/uncommon.joints.html>

Plastic Injection Molding

- Difficulty with flat surfaces
- Larry Maier from UW-Hospital
- Cost per unit produced
- How to adhere plastic surfaces to one another.

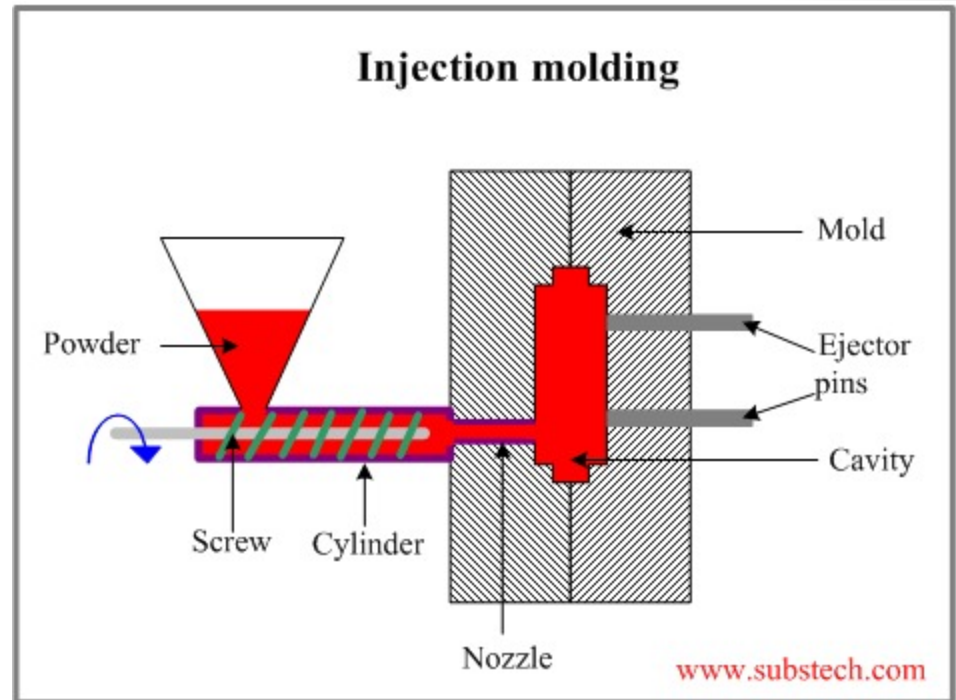

<http://plasticinjectionmouldingdesign.blogspot.com/>

Acknowledgements

- Dr. Scott Springman
- Christina Jordan
- Professor Chris Brace

Questions?