

Portable Recliner

BME 200/300

Rebecca Stoebe, Peter Guerin, Kyle Anderson, Mustafa Kahn

Advisor: Dr. John Puccinelli

Design of a Portable Recliner Chair
Rebecca Stoebe, Peter Guerin, Mustafa Kahn, Kyle Anderson

Abstract

Many people, regardless of having significant disabilities, find that performing simple tasks may become difficult and arduous. In this case the person undergoes dialysis weekly and loses fine motor control of most of his body after treatment. Extreme help is required of an assistant to raise him from a sleeping position to an upright sitting position, and even more effort to raise him from the upright sitting position. The goal is to design a product that can be taken and set up by an elderly person, and allow the person to perform the simple tasks. The product must not weigh more than the elderly woman can bear, and be able to fit in the trunk of a car. The secondary goal for the product is to provide the person with comfort.

Ideas were pooled together about different components of the overall reclining chair. Components such as the footrest, the reclining mechanism, legs, and fabrics were taken into account. The components were researched and weighed against each other in a design matrix, to determine the best combination. It was concluded that the ideal design would utilize a pneumatic lift for reclining, detachable legs and a prop-up foot rest. The product would also be detachable in several parts in order to be light and compactable enough for the client.

Problem Statement

There are handicapped people who require a mechanized recliner to sleep in, but most devices are too heavy and cumbersome to be portable and used when traveling. This device needs to be light and small enough to be transported in the trunk of a car, while being comfortable enough to sleep in. The chair must also be strong enough to fit the client's requirements. The ideal design is for the recliner to be mechanically controlled to lower down into a prone position, and then be capable to lift/tip the person back to an upright position. A secondary goal for the chair is to provide a mechanical force to lift the client to a standing position.

Client background

There are handicapped people who require specialized recliners for sleeping. Stan and Connie, the clients, have had problems with travel due to the lack of such recliners. Stan is a man in his sixties who is looking for a portable, mechanized recliner that will help him stand up.

In 2007, Stan had complications in a knee surgery which led him to have renal failure and a heart attack. Since his heart attack, Stan, who weighs 265 pounds, lacks the strength to stand up and needs to sleep in a mechanized recliner. This recliner helps him stand up using a lift mechanism that tilts the chair upwards (Fig 0). The



Fig 0

recliner he currently uses is too big and heavy to allow for travel, and he is looking for an alternative solution. Stan also wants the recliner to fit him. The recliner he currently uses is too big for him, so he has to put pillows behind him to support his back. Also, Connie will have to carry and set up the recliner, so she is looking for a recliner that can be strong enough to support Stan's weight, while still being light enough for her to carry.

Design Specifications

In order to meet the needs of our client and other people in the same situation as our client, the design needs to meet a few basic qualifications. The first being the recliner must be able to recline all the way into the prone position so that it can be slept in. This means the chair must also be comfortable enough for the user. Another trait that is required by the client is the portability of the recliner. The recliner must be able to fit into a trunk of a car and be able to be carried easily, which means the weight limit is 18 kg in our client's case. Even though the chair must be light, it must be able to support up to 136 kg worth of weight. The recliner would be used for up to 16 hours straight, so the material of the chair would also need to support the creep, or increased load after being used for a while, of the load applied.

Existing Products

Currently there are no true "portable recliner" products available in market. However, there are products that are currently available that assist consumers in standing from a sitting or lying position. The most notable of these products are the mechanical recliners commercially available from many retailers. This product, pictured in fig. 1, often uses a hand-held remote to go from a reclining position, to a sitting position, to a standing position. These chairs can support an individual of 135kg and are electronically operated, however, they weigh over 45kg, and therefore are not portable (1).



Fig 1: Power Recliner (1)



Fig 2: Sleeper Converter (2)

Another commercially available product that is similar to this design project is the sleeper chair series from La-Z-Boy contract furniture. These chairs and couches can be found in many hospital settings and can easily convert from a chair to a bed. The chairs, pictured in fig 2, have a pullout footrest and a back that folds back to rest on the ground in order to convert the chair to a sleeper. This chair can support an individual of up to 225kg, but weighs 90kg and would not be considered portable. (2)

Other portable standing assist products are also available, and many are specially designed for emergency use. The Mangar CAMEL, which is an example of a portable emergency lift, uses inflation to lift a person weighing up to 315kg and, when not inflated, rolls to 76 cm (length) by 20 cm (diameter). This product, shown in fig 3, uses a portable battery to inflate the system, and, while doing so, lift a fallen person to a seated position. The product takes 2 minutes to





Fig 3: Mangar CAMEL

inflate and only weighs 6kg, but is designed for use for fallen individuals and has a limited lifetime (3).

Portable lifting assists are also available commercially for everyday use.

The Up-Lift portable lifting cushions, pictured in fig 4, are devices that are able to be used with any seat, and assist an individual who weighs up to 135 kg in standing from a seated position. These systems use either pneumatic or electrically operated control systems to lift the seat to a standing position. While the pneumatic system is designed as an assist and only supports 70% of a users' body weight, the electric system is a true lift system and is able to support 100% of a users' body weight upon standing. These products are also lightweight, weighing only 6kg, and portable, as they are only the size of a seat cushion (4).

Fig 4: UpEasy power lifting cushion (4)

Components

Footrest

There were many possible solutions to give the recliner a footrest that could be either attached or slid out. The first footrest design that was studied was a footrest that slid out from underneath the seat portion of the chair (fig 5).

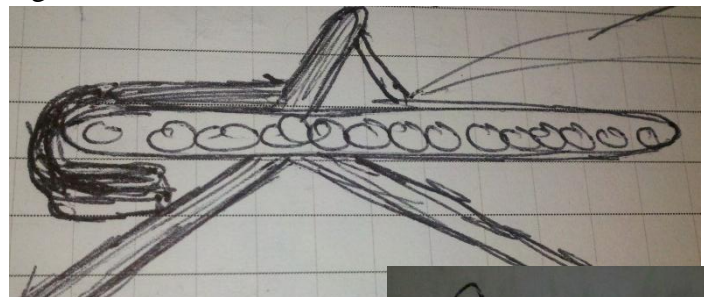

Fig 5 Sliding footrest

As the chair and backrest slid towards the back of the recliner, the footrest would unwrap and slide into position. A minor adjustment that could provide more comfort to the user was considered.

This adjustment consists of a small bar inserted to each side of the footrest which props it up at an angle (Fig

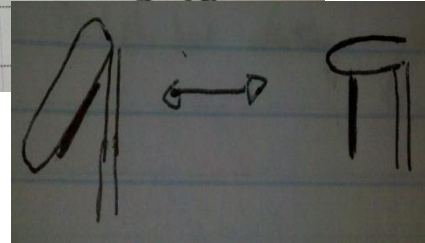

Fig 7 Prop-Up footrest

6). This would allow the users leg to be supported when sitting upright.

A second design considered for the footrest was a simple prop up. When the chair is in a reclining position or prone position, the footrest can be supported with a metal rod (fig 7). An assistant would be needed for this method, as the user cannot pull the footrest upright and place the bar under by themselves.

The final idea that was proposed was a footrest that could be simple pulled out. It is very similar to the first design mentioned, but instead of having to slide the whole chair back for the footrest to come out it can be easily drawn out for the user (fig 8). However this design would also require an assistant to help the user to bring the footrest to a locked position. This design would also require some type of support for the footrest, because it would be highly unstable without anything to hold it up in place.

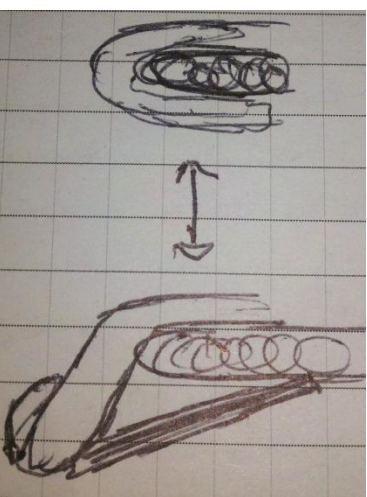

Fig 6 Addition of Small Bar

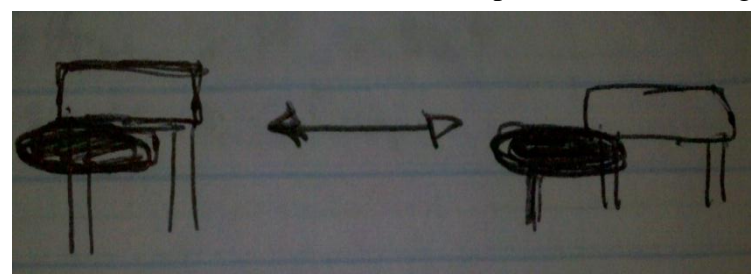

Fig 8 Slide out Footrest

Cushion

The cushions played a major part in the design, because the project is mostly about the comfort of the client. A major decision in the design of the cushions was whether or not they would be detachable or not. If the cushions were detachable it would make the design lighter and more compact for the user. The main idea for the detachable cushions was to have Velcro on the frame and the cushions. When the cushions were placed into the frame they would stick and not slide, and could be easily removed when the user wanted to pack up the recliner. However if the cushions were attached to the design, it would be less parts for the client to carry around and keep track of. This also has the negative effect of not being able to fold the recliner up compactly, because of the bulkiness of each layer.

The second decision involved with the cushions was what type of material to make them out of. The three materials discussed were mesh, velvet, and leather. Mesh was considered initially because the client suggested it. After discussing and testing the mesh material, we realized there would not be a cushion and this would limit us significantly. The mesh would be more of a wrap around the metal rods that are the support of the recliner. The mesh would then be kept taut to support the user. The client suggested it as a good combination of comfort and lightweight compatibility. However from further research the mesh would provide very little comfort because you would be able to feel the construction of the chair beneath it. Velvet was the next material considered. Velvet is a good option for the cushion material because it has a very comfortable smooth texture. The velvet would also give a 'luxurious' look to the chair. However velvet is very difficult to clean, especially when used in upholstery. In order for the velvet to stay clean, the user would need to vacuum regularly and steam clean any stains. The last material that was discussed was leather. Leather is a good material because it is breathable, durable, and rather easy to clean. Although leather seemed like the best option, it is rather expensive and does not due well with temperature. Leather tends to reflect the temperature that is being affected on to it; if it is rather hot the leather becomes hot.

Reclining Mechanism

The reclining mechanism is an important factor in determining the comfort, durability, and ease of use of the recliner. The main designs of the reclining mechanism include torsional springs, bearings with locks, and pneumatic mechanisms with locks.

The torsional spring is used with a lock. The spring will be unstressed when the chair is folded, but it will become stressed when in the normal sitting position. This will make it so that the user will have to put some effort in while reclining, and will have to lock the back support in their chosen position. The lock will guarantee that the chair will not move when the user turns or shifts their weight. Stan will have trouble sitting up without help, so when he wants to he will have to unlock the reclining mechanism and the spring will assist him. This design is simple, and efficient, but the spring may not be strong enough to help Stan sit up.

The bearing with locks also includes a torsional spring. The seat of the recliner remains in the same position, but the back support will tilt. The bearings will make the movement smooth and there will be a torsional spring the will help the user sit up; however, the spring will provide little assistance to the user. There will be locks to allow

the user to lock the back in different positions, but these will increase the amount of the work for the user. This design is simple and cost effective, but it will require the body of the recliner to be bigger.

The best solution to this problem is to have a pneumatic system with torsional springs and locks. This will have the same benefits of the torsional spring and lock, but it will also be stronger and smoother. The torsional spring will be a little weaker, but the pneumatic mechanism will help the user sit up from the reclining position with minimal effort. This design will make the recliner easy to use, durable, and more comfortable.

Standing Mechanism

The team decided that purchasing a portable lifting cushion or lift assist would be a very good option for the portable recliner because lifting cushions available on the market suit the needs of the project well, that is, they are inexpensive, portable, able to be used in a variety of situations, reliable, and suit the client's needs. There are two main options of portable lifting cushions available on the market, and these include power control and pneumatic lifting mechanisms.

The power control option, shown in fig 3, uses an electronic control. The user presses a button on a hand-held control and two support beams slowly raise the cushioned portion of the seat to help the user into a standing position. The pneumatic seat, shown in fig 9, uses a pneumatic lift to assist the user into a standing position. The user shifts forward in the seat and the gas spring automatically activates to help lift them.



Fig 9: Pneumatic lift option (3)

The power control option supports 100% of an individual's weight in going from a sitting to standing position, however, this model can only support 135kgs and costs \$130-200 (depending on the width of the seat and the type of material desired for the cushion). This model is also restrained in terms of space, as it must be plugged into an outlet in order to be used. By contrast the pneumatic model does not need electricity to lift the user, and can support up to 160kgs. This model also costs between \$75-150 (depending on the width of the seat and the type of material desired for the cushion), however, it only is an assist, and only supports 70% of the user's weight to obtain a standing position (4).

It was decided that the pneumatic option will be used in the portable recliner. The pneumatic option is more affordable and also more portable and alleviates the need for electric mechanisms in the chair, which simplifies it for client use as well as improves portability. It was also discussed that, for the needs of the client, the fact that this option only supports 70% of the users' weight would not be an issue, as the client can, at this time, play an active role in standing, and truly just needs assistance.

Legs

The legs are a very important part of the design. They greatly contribute to the weight, portability, strength, and stability aspects of the recliner. The main designs chosen for the recliner were scissor legs, folding chair legs, and detachable legs.

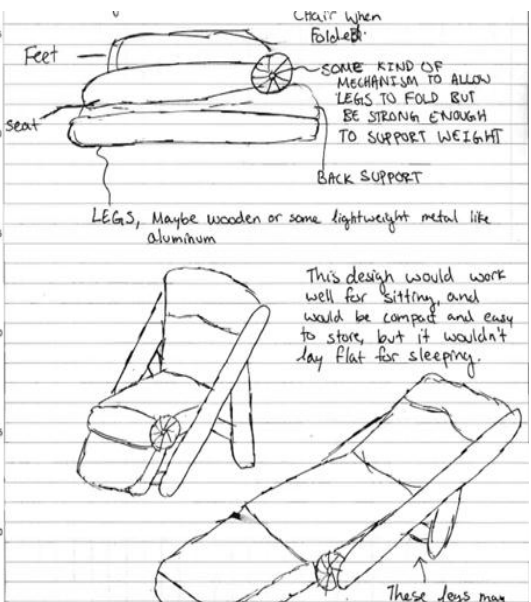

Fig 10 Folding chair legs

There are benefits of having each type of leg, but only one fit with the rest of the design. Some benefits of having folding chair legs are that they make the recliner very portable, light, and strong; however, the design has some major flaws (Fig 10). These legs make it difficult for Stan to stand up because he would sit lower to the ground. Also, the design is capable of reclining, but it doesn't allow the user to lay flat. While the chair in the reclining position, it requires another mechanical component to help the users sit up straight. These legs also constrain the design because they will have to be attached to the back support, head, and main body of the recliner making it harder to improve the design. These legs didn't fit

with the chosen body of the recliner.

The scissor legs also have many benefits (Fig 11). They are very portable because they can be folded in, they are easy to use, they are light, and they would be able to support the user. The main disadvantages of these legs are that they are less durable and have problems with stability. This design fits with the chosen body of the recliner, but there is a more efficient design.

The detachable legs have the most advantages. They reduce the weight of the total design because they can be carried separately. This also makes the design more compact and portable. The reduction in weight will allow for the design of the body to be stronger. Each leg is attached to the body of the recliner separately. This makes it harder to assemble, but increases with strength of the legs. They will be able to support the most weight and will be more durable than the other two designs. These legs would be less expensive and would reduce the manufacturing costs.

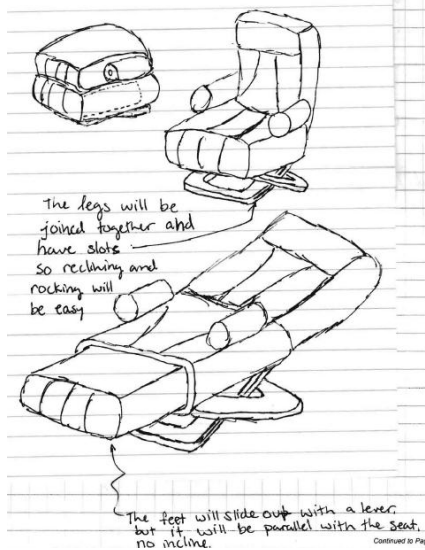

Fig 11 Scissor legs

Design Option #1: Slider

This design, as seen in fig 12, is the most unique of our brainstormed designs, but would also be the most complicated to use and fabricate. The frame has single legs that fold up into the main frame when collapsing. The seat rests on a platform, with the back rest held up by a torsional spring and support bars that lock into place. The leg rest is connected to the seat and hang straight down when in sitting position. The cushions are removable and connect with Velcro straps and strips. The entire seat, leg rest, and back rest part of the chair are connected and on a movable track on the main support platform. The track consists of a number of bearings and support bars across the main frame.



Fig 12 Slider Design

When the individual moves to a leaning back position or down to a sleeping position, then the whole seat unit moves along the track. As the support bars for the back rest move back and under, then the seat moves back, pulling the legs up and over the

front edge of the platform, either stopping at a reclined position or straight out on top of the platform when prone. Before reclining, the platform isn't fully extended and would need to be folded out to provide the support needed, along with additional legs that fold out. The back rest would have pegs/levers to lock it into a reclined or prone position. Then when the individual wants to sit back up to a sitting position, all they have to do is have a second person unlock the locks. The torsional springs in the hip will help lift most of the weight up in a controlled ascent as the person slides the seat forward and the legs rotate down. The bottom edge of the leg rest has an edge for the feet to rest upon. Ideally when collapsing this design, the seat, foot rest, and back rest unit would pull away from the main support platform. Then the seat unit would collapse up into a suitcase like piece, while the platform's legs fold up and the platform either telescopes into itself or folds up on hinges.

This design presents the user with the ability to easily move to a prone position, and to a certain reclining position. The user must simply slide themselves along the track to bring the footrest up, while pressing a button to recline through the pneumatic lift. This design is the easiest for both of these steps, and is even easier for the assistant to the client if there is one present. However this design would take up a lot more area. The recliner would need a greater amount of space to be set up and used. When traveling this may pose a problem when selecting a place to stay, and it may cost more for a room with a bigger floor space. Also this design is the most difficult to compact. The sliding mechanism makes it difficult for the chair to be broken down and put back together, because a breaking point in the base would have to be chosen in the middle. The base would have to be modified at the breaking point by making a gap in the bearings. This gap in the bearings would make it more difficult to slide over the gap and possibly pose danger to hands and breaks in the material due to concentrated stress.

Design Option #2: Directors Chair

This design option, as seen in fig 13, features a rectangular seat 70 by 70cm and back 60cm high by 66cm wide, with indentations of 5cm deep, 5cm away from the sides.

Removable cushions will be placed in these indentations to improve the portability of the seat. Removable, cylindrical armrests were also built into this design for increased user comfort as well as for pulling on or holding onto when the user goes from a laying position to a seated position or from a seated position to a standing position. The back of the chair also features a headrest measuring 15cm wide by 10cm high for increased user comfort in the seated position. The footrest in this design consists of a rectangular slab measuring 42cm long by 60 cm wide with an indentation 5 cm deep, which will be filled with another removable cushion. It is important to note that these dimensions may be changed to fit the specific needs of the client.

The back of the seat connects to the seat through a metal rod that runs through the sides of the seat and the bottom of the back, allowing the back of the seat to be rotated relative to the seat. This back reclines by using torsional springs that can be locked in a compressed position for laying or an extended position for a seated chair. The footrest is attached to the seat in a similar manner and can be raised to a laying position through a similar mechanism. These torsional springs can be unfastened from the footrest and back of the chair to allow the seat to fold on top

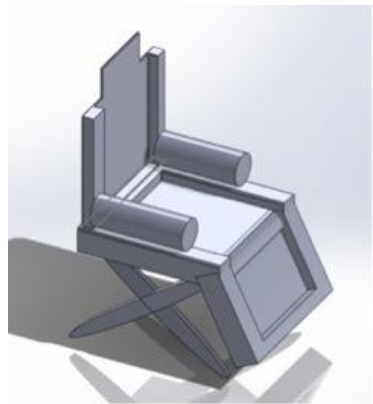

Fig 13 Directors Chair

of and the footrest to fold under the chair seat to increase portability. The locks specified in this description will be of the push knob with latch variety for ease of use.

The legs of this design option consist of two bars connected by a metal rod going through the center of both sets in order to increase stability. These bars measure 46cm long by 6 cm wide by 4 cm deep and are attached to the bottom of the seat but are removable in order to increase portability. They are arranged such that the seat of the chair is 50 cm high. Additionally, this model will have the pneumatic UpEasy portable seat described in the standing mechanism section attached to the base to assist the user in going from a seated to a standing position.

Because of the removable parts of this chair and the fact that the chair can fold up like a suitcase, this design option is the most portable and compact out of the three. It is also for this reason that this design option is the lightest. However, this minimalist design raises concerns about the stability of this design, as well as its ability to be sat in or laid in over long periods of time. Finally, because this chair does not have a great deal of support, it will also be the least comfortable to lie in.

Design Option #3: Lazyboy

This design option also features a traditional seat bottom and back of dimensions 70 by 70 cm and 60cm high by 66 cm wide respectively. Similarly to the other designs, these two parts also have indentations 5 cm deep in which removable cushions will be placed. This design features armrests that are not removable and are rectangular. They will be padded, but their primary use will be to aid the user in going from a laying position to a seated position, allowing him to grab onto the armrests and use them as assists in pulling himself up. These will also be useful in assisting the user in going from a sitting to a standing position, as he can use the armrests as bases of support to help him up. It is important to note that these dimensions may be changed to fit the specific needs of the client.

The legs of this seat are rectangular in shape and, if needed will have crossbars spanning the sides of the chair on the legs for extra support. Additionally, these legs are non-removable in order to increase stability. The chair seat is 50 cm off the ground, but this may be changed in the final design based on the needs of the client. The footrest on this model slides out from under the chair to become the portion of the bed needed for the legs and feet. When it is completely slid under the chair, it can be locked in this position and acts as a footrest that is 56 degrees above the vertical. When completely pulled out from underneath the chair, the footrest portion measures 45 cm and the structure can be used as a bed when a cushion is placed in the built-in indentation. The footrest can also be locked in this extended position so that the structure does not slide back in during the night. The locks specified in this description will be of the push knob with latch variety for ease of use.

The back of this chair reclines in a manner similar to a beach chair. That is, the seat is regularly locked in a seated position, and when unlocked can be tipped back to a prone position and locked again. Supports for this portion of the recliner can be folded out of the back of the chair. When fully extended into the sleeping position, this model

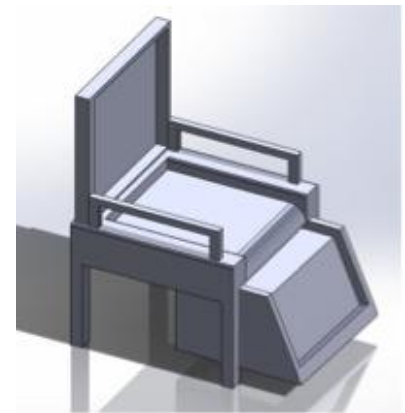

Fig 14 Lazyboy Design

is 175 in length, but this may be extended in the final model because of the height of the client. Additionally, this model will have the pneumatic UpEasy portable seat described in the standing mechanism section attached to the base to assist the user in going from a seated to a standing position.

Because this design option doesn't have any torsional springs or other complex mechanisms it will be very easy to use. Additionally, the large base of support and the bulky footrest make this model very durable and stable as well as being very well suited to be sat in for a long period of time. However, because of this increased support, this model is rather bulky, which raises concerns about its portability and weight. This model also does not have an assist (besides the aforementioned armrests) to help the user go from a prone position to a laying position, which could potentially be problematic for our client.

Design Matrix

Design Matrix For Portable Recliner								
		Slider		Lazy boy		Beach Chair		
	Weight	Grade	W. Grade	Grade	W. Grade	Grade	W. Grade	
Comfort	0.2	6	1.2	7	1.4	6	1.2	
Ease of Use	0.15	5	0.75	6	0.9	7	1.05	
Compact	0.1	7	0.7	5	0.5	7	0.7	
Client Satisfaction	0.15	8	1.2	5	0.75	3	0.45	
Weight	0.1	7	0.7	4	0.4	7	0.7	
Feasibility of Construction	0.1	7	0.7	6	0.6	7	0.7	
Assembly	0.1	4	0.4	6	0.6	7	0.7	
Durability	0.05	6	0.3	7	0.35	3	0.15	
Cost	0.05	5	0.25	5	0.25	5	0.25	
Total	1		6.2		5.75		5.9	

Table 1: Three Alternative Preliminary Designs in a Design Matrix. Design matrix comparing the three main preliminary designs that our group brainstormed. Categories were selected and weighted, then given a score from 1-10 and multiplied by the category weight.

Early on in the brainstorming and initial design process we made several design matrices on individual parts. These matrices ended up being more instrumental for brainstorming, but didn't contribute very much to determining our final design. In addition, we generated one main large design matrix to evaluate the three main designs that we brainstormed. The category weights were decided through discussion between the group members and differencing opinions regarding the importance of the categories. The categories identified were (in order of importance): comfort, ease of use, client

satisfaction, ability to compact, weight, feasibility of construction, assembly, durability, and cost.

Comfort was weighted on the ability of the design to be slept in for two nights straight, and was our highest weighted category because it is our client's top priority. Ease of use relates to portability and how simple it is for the client to move the device around and operate it. This was rated second highest due to Connie's lack of ability to carry heavy objects. Ability to compact is rated on how small and how few pieces we think would be involved in collapsing the structure. The recliner is going to be used for traveling and is being transported by car, so the recliner must be compactible. Cost and durability were determined to be the least important. Cost is not very important because the current competition products come at a hefty price. The durability was decided to be of little importance because the recliner would be used only 1-3 times a year for a max of 3 days. This would give very little wear and tear to the chair.

The final scores were calculated and, as can be seen in Table 1 the slider design was determined to be the best of the three. This was mainly due to a higher rating in the client satisfaction, although all three designs were very close. Based on input from the clients themselves, we determined that the lazy boy and beach chair designs weren't quite as good for what they are looking for. Looking at the table, many of the categories resulted in very similar ratings.

The design matrix in Table 1 and the individual comparisons of the leg designs, leg lifting mechanisms, armrests, and reclining mechanisms revealed to us that our complete designs didn't fully suit what we, as a group, were thinking of for this project. As a result, the final design is a combination of several designs.-

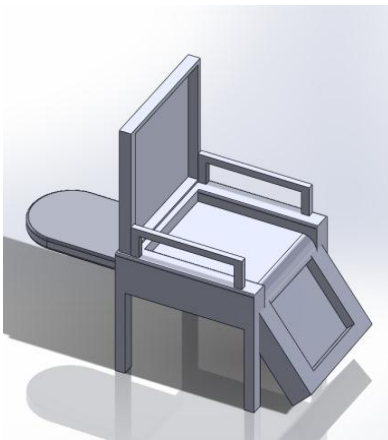

Fig 15
Final Design

Final Design

The final design does not utilize all the components from any single design; instead it uses components from each design. The recliner has four main detachable parts; the legs, the chair, the stability platform, and removable cushions. The user can attach legs to the base so the chair can be set up to two to three feet off of the ground. The chair includes the base, where the user sits, along with a

footrest and back. The footrest is the prop-up mechanism that was shown earlier in fig-7, it would also include a torsional spring to help the user bring the footrest up. The last part of the chair is the back, which is supported by the recliner stability platform. The back is supported by a pneumatic lift so that the chair can recline all the way to a prone position and back up to a sitting position. The last main component is the removable cushions. The removable cushions will be able to be attached to the chair while using it by Velcro. This will make the chair more compact and easier to travel with

Future Work

The biggest part of our future work will be choosing the materials and then assembling the chosen final design. This includes the main body of the chair, the pneumatic system or torsional springs, the chair back, the cushions, the cushion attachment mechanism, the legs, the collapsible mechanism, and the leg extension

mechanism. All of this involves machine shop skills and fabrication that will be time consuming. Also, an accurate Solidworks model of our final design needs to be created, so we can run strain/stress/force analyses on it with Solidworks and/or ANSYS.

We need to choose the specific materials, whether it be aluminum, steel, or various alloys of them. Then order the materials and when they arrive machine them to the right sizes and so they fit together with the proper mechanics and strength. The legs need to be light enough, but strong enough to support the chair and still be collapsible or removable.

The pneumatic system will require a support plate or bars on the backrest and a second short platform off the back parallel to the seat. The torsion springs will require the implementation of the springs into the junction of the legs and back of the seat. This power system needs to be strong enough to lift the client up along with the parts of the recliner that is being moved.

After building our whole design we will do product testing and determine that the recliner meets client satisfaction and is safe. This consists of testing with weight to determine that it is strong enough. Then testing with our group members to ensure that the mechanisms to lay prone and extend the leg rests are completely functional. The final step will ideally be to give the product to our client and have Stan Fox try out the recliner.

References

1. "Rialto Luxury Lift Power Recliner." *Www.la-z-boy.com*. La-Z-Boy, 2012. Web. 16 Oct. 2012. <<http://www.la-z-boy.com/Product/6391-7971/>>.
2. Product Catalog | La-Z-Boy Contract Furniture." *La-Z-Boy Contract Furniture*. La-Z-Boy, 2012. Web. 17 Oct. 2012. <<http://www.lzbcontract.com/Impublic/productCatalog.do?option=category>>.
3. "Camel (Battery) - Camel Emergency Lifting Chair | Emergency Lifting Equipment - Mangar International." *Mangar International: Independent Living Solutions*. Mangar, 2012. Web. 16 Oct. 2012. <<http://www.mangar.co.uk/product/MPCA060200/camel-battery>>.
4. "Up-Lift Technologies Inc. Lifting Seats." *Up-Lift Technologies Inc. Carex Health Brands*. Carex Health Brands, 2012. Web. 17 Oct. 2012. <<http://www.up-lift.com/Products/Products/lifting-seats.php>>.
5. Dr. John Pucinelli
6. Stan and Connie Fox
7. Meriter Home and Health

Appendix

PDS**Project Title: Portable Recliner****Team Members:** Kyle Anderson, Peter Guerin, Mustafa Khan, Rebecca Stoebe

Date: 10/5/12

Problem Statement: There are handicapped people who require a mechanized recliner to sleep in, but these devices are too heavy and cumbersome to be portable and used when traveling. This device needs to be light enough and small enough to be transported in the trunk of a car, while being comfortable enough to sleep in and strong enough to fit the client's requirements. The goal is to design it to be mechanically controlled to lower down to prone position and be able to lift/tip the person up to or close to a standing position

Function: To develop a portable reclining chair that can accommodate the specifications of our client, Mrs. Constance Fox. This device should ideally be comfortable enough to sleep in, and be able to recline and have a footrest, as well as assist in lifting the individual from a sitting to a standing position. Additionally, this device should be portable; it should ideally be collapsible and weigh no more than 40 lbs.

Client Requirements

- Collapsible; should be able to fit in the trunk of a car Cadillac (<0.42 cubic meters)
- Able to recline
- Should contain a footrest
- Able to lift the individual sitting in it to a standing position
- Able to allow individual 175 cm to sit or lay comfortably
- Able to support 1350 N/136 kg
- Is comfortable; can be slept in
- For travel use

Design Requirements**1) Physical and Operational Characteristics**

a. Performance Requirements: This recliner should be able to support 1350 N of weight for up to 16 hours at a time (max foreseeable time is 16 hours). It should also be able to hold a 136 kg person who sits from a standing position. It also must be able to lift this individual from a sitting to a standing position. Finally, it must be able to support this individual in a reclining position.

b. Safety: This chair may be sat in for hours at a time and should not cause body strain (back, neck or other) during this time. Additionally, the chair should never buckle or collapse under the weight of the individual. The chair should also not pinch or otherwise harm the user. Finally, the seat should not move while the individual is being seated or raised.

c. Life in Service: This product should be able to be used for up to 24 hours at a time and should be able to be sat in and the individual lifted or seated multiple times in a day (standing to sitting or vice versa 8 times per day). Similar products have a three-year warranty on the electrical mechanisms. However, the product will only be used for traveling which only occurs 3-4 times per year over a 1-5 day span.

d. Operating Environment: For indoor and stationary use only. However, it will be used in many different locations. This will be primarily be used in hotel-room locations (18-24 degrees C, 35-50% humidity), but could be stored in potentially hot or humid environments (in the trunk of a car) for several hours. Thus, this environment could range up to 100% humidity and have a temperature range between -23 and 93 degrees C for 8-12 hours maximum). This product will primarily only be handled and used by the client and their spouse, but other individuals may also be around or be handling the product. Therefore, the product should be relatively safe for people of smaller size and the mechanisms to use it should be relatively intuitive.

e. Ergonomics: Should be able to comfortable seat a man that is 175 cm. The seat should also not cause back, neck, shoulder, or leg pain if an individual is sleeping in it when it is reclined. The seat should also be able to raise and recline without causing strain to the person who is sitting in it.

f. Size: Product should be able to fit in the trunk of a car (<0.42 cubic meters) or be checked as baggage on a plane (68x53x35 cm to not be considered oversize). Therefore, chair should be collapsible.

g. Weight: For portability reasons, product should weigh less than 18 kg. As stated previously the chair should be able to seat, recline, and raise a person who is 136 kg.

h. Materials: The materials used should be lightweight in order to keep the chair within the weight limit and should be mildly non-corrosive. Soft materials should be used for the outer portion of the chair so that it is comfortable for the user.

2) Production Characteristics

a. Quantity: 1

b. Target Product Cost: Similar non-portable lift chair range between \$600 and \$1600. Client budget is \$200.

3) Miscellaneous

a. Client: Our client was very unsatisfied with the previous result of this design project, which she described as a “dolly with a lawn chair.” Additionally, the individual that this chair is being designed for must undergo daily dialysis treatment, involving 2 needles, which should be taken into account in the design of this product.

b. Competition: There are many non-portable lifting recliners in market and also many portable lift systems/chairs. However, there are no known portable recliners with built in lift systems currently on the market.

Lifting Recliner examples:

- <http://www.la-z-boy.com/Furniture/Lift-Chair-Recliners/>
- <http://www.usmedicalsupplies.com/Lift-Chairs.htm>
- <http://www.livingincomfort.com/indoor-store-back-pain-relief-lift-chairs.html>

Portable Lift System examples:

- <http://www.oakpointemedical.com/mangar-camel-86.html>
- <http://www.portableliftchairsllc.com/>
- <http://www.dynamic-living.com/product/upeasy-power-lifting-cushion/#clear>