

# Design of Weight Distribution Monitoring System

Final Report  
December 11th, 2013

---

## Team Members

Xiyu (Steve) Wang (Team Leader)  
Dalton Hess (Communicator)  
Kiersten Haffey (BSAC)  
Andrew Vamos (BWIG)  
Jacob Hindt (BPAG)

## Clients

Professor Willis J. Tompkins, Ph.D  
Carol Rohl

## Advisor

Thomas Yen, Ph.D

Biomedical Engineering Department  
University of Wisconsin - Madison  
1415 Engineering Drive  
Madison, WI 53706

# Table of Contents

|  |    |
|--|----|
| Abstract.....                                | 3  |
| Problem Statement: .....                     | 4  |
| Background Information: .....                | 4  |
| Mechanism of Weight Distribution: .....      | 5  |
| Design Motivation and Criteria: .....        | 6  |
| Design Requirements.....                     | 6  |
| Current Competing Design.....                | 6  |
| Previous design.....                         | 7  |
| Midsemester Design: .....                    | 8  |
| Methods of Biofeedback Designs .....         | 8  |
| Visual Biofeedback Designs.....              | 10 |
| Modification of Midsemester Design: .....    | 13 |
| Experimental Testing:.....                   | 14 |
| Arduino Microcontroller and Programming..... | 16 |
| Final Design and Fabrication: .....          | 17 |
| Timeline: .....                              | 19 |
| Future Work: .....                           | 20 |
| Conclusion: .....                            | 21 |
| Acknowledgements: .....                      | 21 |
| References: .....                            | 22 |
| Appendix: .....                              | 23 |
| Design Contact Information.....              | 23 |
| Additional Pictures.....                     | 24 |
| PDS.....                                     | 26 |
| Arduino Code.....                            | 29 |
| Materials.....                               | 32 |

## Abstract

---

Stroke victims commonly suffer permanent physical disabilities such as hemiplegia. Hemiplegic individuals face many challenges in their recovery including inability to balance, loss of ambulation, and muscular atrophy. Physical therapy remains one of the most effective methods of treatment for these conditions. As such, our client believes that a device allowing hemiplegic individuals to assess their standing weight distribution will be highly beneficial to their motor function. However, most weight distribution measurement devices are only available at the clinical research level and are not available for home use. Here, the design of a weight distribution sensor board that is portable and easy to use for those with limited motor function is proposed. This design utilizes load cells and audio biofeedback to provide subjects with easily interpretable cues that can be used to practice proper weight distribution.

## **Problem Statement:**

The client, Carol Rohl, is a hemiplegic individual who suffered a stroke nine years ago and lost all sensation on the left side of her body. She is ambulatory but suffers from improper weight distributions causing great mental and physical fatigue during standing and walking activities because of numbness on her left side. This project is a portable biofeedback training device that will enable the client to practice standing with proper left and right weight distribution. Hopefully by practicing with the device, the client will be able to improve her balance, increase her mental and physical endurance, and enhance the overall quality of life.

## **Background Information:**

Stroke is a major issue in the U.S., with more than 800,000 yearly occurrences and 133,000 deaths every year. 88% of these stroke victims in the U.S. are greater than 64 years of age. As a result, stroke occurrences are set to increase in correlation with the increasing age of the baby boom generation <sup>1</sup>. This elicits a need for improvement of current treatment methods for those who suffer from stroke. Improving rehabilitation methods for stroke victims will reduce the impact of strokes and improve patient quality of life, resulting in overall societal and economic benefits.

The most common cause of stroke is the occlusion of an artery within the brain. This results in an inadequate supply of glucose and oxygen to the surrounding tissue, leading to a reduction in oxidative metabolism within the cells. Ultimately, cell death will occur within a few hours of the blood flow restriction <sup>2</sup>. Many stroke survivors experience brain damage that can leave their body permanently disabled. Hemiplegia is one of the common conditions resulting from a stroke. Depending on the severity of the event, individuals can suffer a loss of sensation from on an entire half of the body. This can have substantial consequences on an individual's motor function including impaired balance, complete loss of ambulation, spasms, muscular atrophy, and osteoporosis <sup>3</sup>.

Physical therapy has consistently shown to be an effective means of treatment for hemiplegic individuals, exhibiting measured results showing improvement in overall health, fitness, and ambulation in patients. Types of treatment include effort training, gait training, and muscle training. Due to a large diversity among treatment methods, it is difficult to select an ideal therapy regimen. Still, common underlying themes are present in the different regimen. One such theme is consistency; like any exercise regimen, it is extremely important that patients keep up with their program and do not fall into a cycle of inactivity <sup>3</sup>. As such, it is important that an activity not be exceedingly difficult for an individual to perform as they may get discouraged.

## Mechanism of Weight Distribution:

Weight distribution is determined by calculating the center of pressure affected by the vertical forces of the foot and the moment about the ankle (Figure 1). In a standard force plate, there are four sensors, one in each corner that take readings from the deflection in the plate's surface. The load on the plate deforms each sensor differently, depending on position and direction. This placement is used to increase the accuracy of the device, recognizing movement in the anterior-posterior direction and the lateral-medial direction. The accuracy accommodates for the fact that when standing, the body's center of mass is in constant motion. The body responds to this movement by adjusting the center of pressure beneath the feet<sup>4</sup>. The center of pressure is found due to the force platform's ability to access the forces along three perpendicular axes and find the moments about those axes. Finding the center of pressure can assess how far an individual's weight distribution strays from the norm. The normal weight distribution is located in the center of both feet. The center of pressure is determined by using the forces and moments along the line of action.

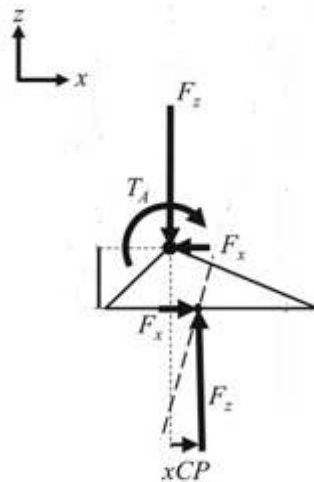

**Figure 1:** The diagram depicts the vertical forces and resulting moment present in the foot as a result of the center of pressure moving past the ankle<sup>4</sup>.

## Design Requirements:

Before starting the design process in the fall of 2013, the balance biofeedback design specifications were compiled. Later in the semester, the PDS was updated to reflect the current needs of the client. The more important requirements include being portable and allow the client to carry the device with one hand, be thin to enable the client to step onto the platform with relative ease, not require the client to look down or hold devices since this can cause unbalance, and that the design will be used on metal floors so it should not contain metal hinges or other materials hazardous to the living space.

## Current Competing Designs:

Currently, there are multiple designs and products that perform weight distribution analysis. Three of the most noteworthy examples are the Wii Balance Board, a standard force plate, and the Balance Master (Figure 2). Wii Balance Board is constructed to a similar shape and size of that of a common household scale. The device runs on four AA batteries and uses Bluetooth technology to emit signals to an external processor that can interpret force data. The interfaces of the Wii are programmed to work with modern electronic devices for feedback display. The overall design is similar to a force plate using four sensors to measure the center of pressure of the user. The Wii Balance Board is not an optimal solution for the client because the board has a high platform, making the device difficult to step on to. In addition, the client stated that a television hookup was possible, but not desired as it reduces portability.

The standard force plate has one force sensor in each of the corners of the plate. The mechanics and specifics of a force plate design are described in the previous section explaining weight distribution. These devices are expensive and come with extensive software packages. It would be difficult to modify these systems as they are already fairly complex.

The SMART Balance Master, shown in Figure 2, is a device used clinically to train patient's balance. The device uses a force plate that can rotate and swivel as well as perform simulations to train patients to balance. The device includes more functions than the client needs to practice left and right weight distribution and is very expensive, costing \$90,000<sup>5</sup>.

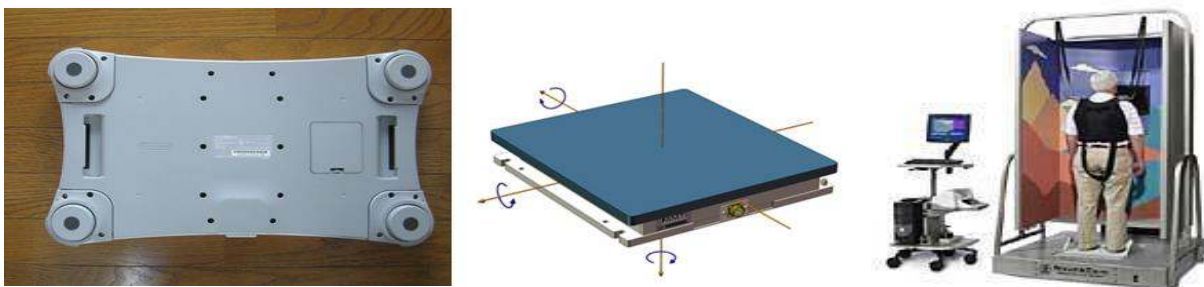

**Figure 2:** View of the bottom of the Wii Balance Board (left), force plate demonstrating the three perpendicular axes that moments can be calculated about (middle), and SMART Balance Master (right).

## Previous design:

The previous design was constructed with clear and durable pieces of polymer connected by a series of hinges for folding and portability (Figure 3). The device had two Flexiforce sensors, a type of FSR, on the lateral sides of the feet. The Flexiforce sensors are versatile, durable piezoresistive force sensors that measure relative changes in applied load. The device provided biofeedback through a handheld apparatus wired to the device and contained an array of LED that lit up according to the client's weight distribution. The device was functional but broke after minimal use due to the fragile wires. Additionally, the client had several complaints with this design. The handheld device made it difficult for the client to concentrate on her weight distribution. The device should have a hands-free approach to the biofeedback method and not require the client to look down at the floor or on her body. The client disliked the hinge-folding function as the hinges made the device harder to move and damaged her hardwood floor.

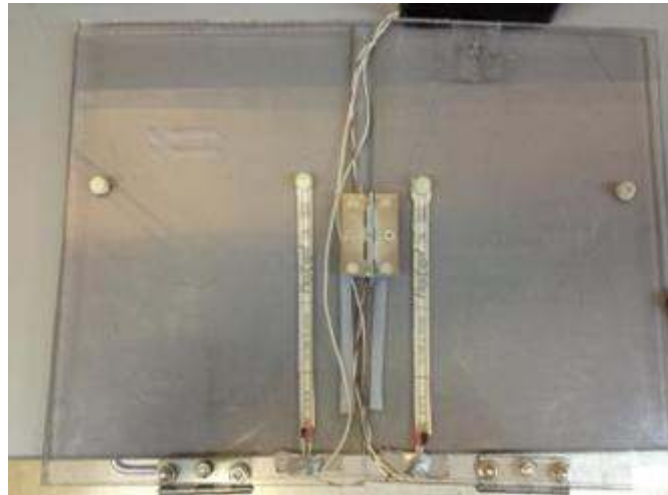

**Figure 3:** Top view of the previous semester's design. The housing unit for the LED array is partially visible along the top of the image.

## Midsemester Design:

The midsemester design intended to utilize a thin board design with four flexiforce sensors, one at each corner of the force plate. The flexiforce sensors would then feed into a microprocessor and output to its various biofeedback method. This design allowed for more accurate readings if the client would be standing towards the edge of the force plate. In addition to the increased accuracy, there is a larger market possibility for this product if it is commercialized. This is due to the designs ability to detect unbalance in two planes. The main variable altered within the design matrix was the biofeedback mechanism. The three biofeedback systems that were considered included visual, vibrational, and auditory.

## Methods of Biofeedback Design:

The visual system involved projecting a light gradient onto a wall that shifted based on the clients weight distribution (Figure 4). One possible idea was to have lasers that have been modified to shape into arrows on the wall. This could be done with one straight array of light for the client or arrays in two dimensions to represent left and right orientation as well as front and back orientation. If the client leans too far right, a red arrow point left would be displayed. Likewise if she maintains good weight distribution, then the two middle green light will be displayed.

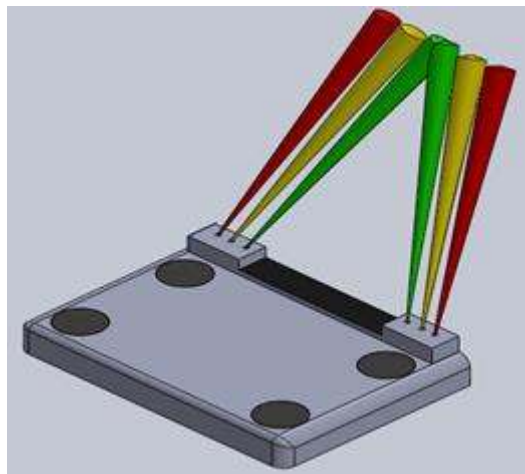

**Figure 4:** SolidWorks model depicting a visual feedback system. All lights are active for modeling purposes only.

The vibrational system would include vibrating motors on both sides of the right foot since the client does not have sensitivity in their left foot (Figure 5). A more developed product could include motors on all four corners to allow the user to adjust based on where sensation is felt in all four directions. This system is based on increasing vibrational intensity on the heavier side until the client corrects her balance.





**Figure 5:** SolidWorks model depicting vibration feedback system. The vibrational motors can be seen, securely integrated within the framework of the board.

The audio feedback system gave the client the ability to hear the direction of leaning by a beeping noise varying in intensity based on how far off the weight distribution was (Figure 6). This model would not be as effective if applied to a two-axis model similar to the other feedback options.

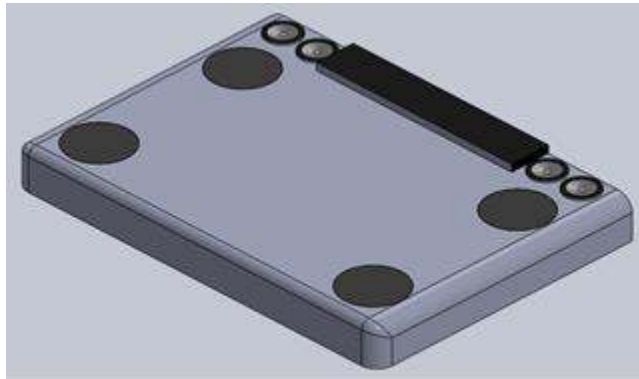

**Figure 6:** SolidWorks model depicting audio feedback system. Speakers allowing for audio feedback can be seen integrated within the framework of the board.

The three feedback systems were analyzed on the design matrix (Table 1). Although the vibrational option would be the cheapest, client comfort and effectiveness may be a concern. Vibration can be an annoyance with continuous use and would not be suitable for the client. In addition to the discomfort, it might not be effective either. Continued vibration often leads to numbing, in result hindering the foot's ability to locate the source of vibration as well as the intensity. This could lead to missed or even false corrections.

| Design Criteria (weight) | Visual Feedback | Vibrational Feedback | Audio Feedback |
|--------------------------|-----------------|----------------------|----------------|
| Ease of Use (30)         | 5   30          | 4   24               | 4   24         |
| Effectiveness (25)       | 4   20          | 2   10               | 4   20         |
| Comfort (20)             | 4   16          | 2   8                | 3   12         |
| Safety (15)              | 4   12          | 3   9                | 3   9          |
| Cost (10)                | 3   6           | 4   8                | 3   6          |
| Total (100)              | 84              | 58                   | 71             |

**Table 1:** Design matrix for various visual biofeedback designs. The yellow represents the winner of each category.

Another, more effective, option would be audio feedback. The design showed promise in the fact that it only relies on the user to listen to beeps and correct based on what is heard. Many speaker systems have been integrated with microcontrollers before so programming would not be too difficult with the right speakers. It may be nice to not be required focus on anything besides a noise but the consistent beeping could also be an annoyance. Also it may be difficult for the client to determine the magnitude of how much to correct her balance because it is based on her acuity to depict varying audio intensities.

The visual option may vary in price based on the projection method used but it appears to be the best suited for the client. Based solely on the ease of use, effectiveness, and comfort this design stands out. If the laser route is taken, the cost is very low and it still maintains a user-friendly design. The client simply has to view the visual in front of them and adjust accordingly considering they have a space to project the lights.

### **Visual Biofeedback Designs:**

After deciding on visual biofeedback, several options were explored to display the feedback visually. Each design still incorporated the four force sensitive resistors as well as Arduino microprocessor as shown in the previous three designs. Each of the following designs will focus on relaying the weight distribution measurements back to the client in a visual format.

The first visual feedback design is the projection feedback (Figure 7). A projector will be mounted on the force plate that will connect to the Arduino microprocessor to output a live image. The tentative idea is to display an animated person that leans left or right in

correspondence with the weight distribution. If the client is focusing more weight on their right leg, the animated person will lean to the right with further lean indicating more distribution. This will allow the device to integrate visual feedback with the force plate, allowing the client to only carry one device for portability. The display will also be intuitive and will allow the client to easily determine where her weight distribution lies.

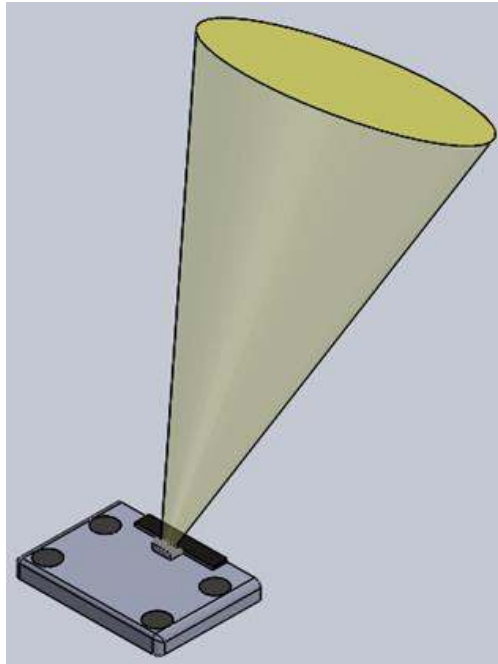

**Figure 7:** SolidWorks model portraying the projection system. The projector will display an image on the wall approximately at eye level.

The second visual feedback is the laser feedback (Figure 4) as described above. Instead of a projector, six lasers will be aimed from the force plate to a point on the wall at eye-level. The laser will include lights that are either red, yellow, or green. If the client shifts her weight distribution too far to the right, then the right red laser will turn on. The client will then aim to keep the middle green lasers lit.

The third visual feedback is the wireless and mounted feedback (Figure 8). This design will incorporate an external display that connects to the device via Bluetooth that can be mounted on the wall. This design can allow for many displays but the tentative plan was to incorporate the same display system as the laser design. Instead of having lasers hitting the wall, the wireless display move from left to right depending on the weight distribution.

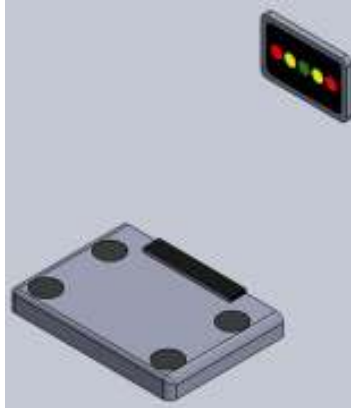

**Figure 8:** A SolidWorks model of the wireless/mounted visual feedback design. The external display will be attached to the wall or held up by a rod or some other apparatus. It will use the same display as the laser feedback.

Three more designs were created with another design matrix to determine the design most suitable for the client and her needs (Table 2). The laser feedback design was selected as the final design due to several factors. Due to the client’s limited mobility, the design’s focus should be on the ease of use of the device so that she does not need to exert excessive effort to use the device. The laser design incorporates the visual display on the force plate and allows the client to only carry one device. It is lighter than the projector design, allowing for further portability. The wireless design would allow for a higher variety of visual display but the addition of the secondary device would inconvenience the client. Although the laser design is not as accurate as the projection design due to the gradients allowed for weight distribution sensitivity, with an overall focus on ease of use and convenience for the client, it appears that the laser design is the most suitable design for the client and their specific needs.

| Design Criteria (weight) | Projection | Lasers | Wireless / Mounted |
|--------------------------|------------|--------|--------------------|
| Ease of Use (30)         | 3   18     | 5   30 | 3   18             |
| Effectiveness (25)       | 5   25     | 4   20 | 4   20             |
| Comfort (20)             | 4   16     | 4   16 | 3   12             |
| Safety (15)              | 5   15     | 4   12 | 5   15             |
| Cost (10)                | 3   6      | 5   10 | 2   4              |
| Total (100)              | 80         | 93     | 64                 |

**Table 2:** Design matrix for the various visual biofeedback designs. The yellow represents the winner of each category.

## Modification of Midsemester Design:

After presenting the initial design matrix, discussions with the client provoked major changes within the design matrix. The main changes involved pertained to usability and durability. Usability was implemented into the matrix so that the project would be specified in accordance with the client’s home and physical limitations. In the client’s living space, where she intended to use the design, the walls were either rounded, windows, or covered with picture frames. Although effective, the winning visual feedback design was severely docked for usability by the client because the lights would not be easy to see on these covered walls. As for durability, the visual was reduced again based on the conditions of use and the upkeep of the lasers or projections needed for the design. In order to enable the laser lights to reach eye level of the client, the design would utilize a mechanism that turns the array of lasers. Because the client cannot bend over to turn the laser array, this design would be less usable for the client. Using the audio biofeedback board, the client will not have to bend down, and the device can be used in an area without a large blank wall for reflecting the laser projection. While a speaker has the potential to break, the board will have less dynamic components than the visual board with rotatable laser array.

| Design Criteria (weight) | Visual Feedback | Vibrational Feedback | Audio Feedback |
|--------------------------|-----------------|----------------------|----------------|
| Effectiveness (40)       | 4   32          | 2   16               | 4   32         |
| Usability (25)           | 2   10          | 2   10               | 4   20         |
| Durability (20)          | 2   8           | 5   20               | 4   16         |
| Safety (10)              | 4   8           | 3   6                | 4   8          |
| Cost (5)                 | 3   3           | 4   4                | 5   5          |
| Total (100)              | 61              | 56                   | 81             |

**Table 3:** displays the final matrix design matrix that show the selection of feedback method. The yellow represents the winner of each category.

Additionally, our client purchased the Health O Meter HDL645KD-63 Glass Digital Scale, a digital lithium ion battery operated scale with 4 load cells, one in each corner. The client felt that because the circuitry could be packaged into the scale in a compact and portable fashion that the scale would be more effective for a custom manufactured board with force sensors. The scale also has another bonus as it is designed for commercial use and allows us to simply reuse its packaging. Load cells in a scale such as the Health O Meter were elected to be used over the

Flexiforce sensors as they were already integrated into the Health O Meter scale. On a basic level, load cells are a variable resistor. When a force is applied to an end of a beam, the beam deflects. In a strain gauge the deflection corresponds to a change in resistance. Using a wheatstone bridge small changes in resistance can be transformed to small changes in voltage. We aim to isolate the load cells and utilize them to measure weight distribution rather than total weight.

## **Experimental Testing:**

The Health O Meter HDL645KD-63 Glass Digital Scale uses 4 load cells to measure weight. Initially, attempts were made to modify existing scale circuitry to measure weight distribution rather total weight across the board. However, no diagrams were available regarding the circuit board or load cells in the scale. Connections between the scale and circuit were tested using the circuit board in the scale, using the battery in the scale as a power source. A non-inverting amplifier was used because the voltages measured are on the scale were of millivolts. Each wire was tested with and without an applied load on each of the four load cells to determine how the output changed. Because only wires from the rear load cells' output changes, more research was done to determine how the load cells were integrated to the circuit.

Based on load cell research<sup>7</sup>, scales depend on resistors arranged in a wheatstone bridge. A wheatstone bridge allows small changes in resistance to be measured. Deflections in the strain gauge, or load cell correspond to changes in resistance and therefore voltage. When a load is applied, resistance increases, causing a change in the voltage output. A wheatstone bridge converts small changes in resistance into voltage differences. Because the design of the original circuit board was not discernable the load cells were detached and removed from the original circuit.

Isolating the load cell and testing them individually with a differential amplifier of 100 gain, voltage did not vary as expected. It was determined that load cells each vary as half of a Wheatstone bridge. When two are used in conjunction they form a whole wheatstone bridge. A differential amplifier was used to amplify the difference in voltage because changes in voltage were on the scale of millivolts. For calculating the expected output variation in the circuit, the equation given (Figure 9) was utilized. The Arduino Leonardo has a resolution of only 4.9 mV so it would not be able to measure a deflection less than 4.9 mV.

**Figure 9:** This equation gives the voltage output of a differential amplifier.

The circuit design consists of two load cells connected in parallel. The three wires of each load cell (orange, gray, and yellow) corresponds to input, ground, and output respectively

(Figure 10). This configuration combines two load cells and forms a wheatstone bridge. With the connection of each yellow wire from each load cell to the differential amplifier, the voltage changes as force is applied. For example, placing more force on the right load cell increases voltage and vice versa.

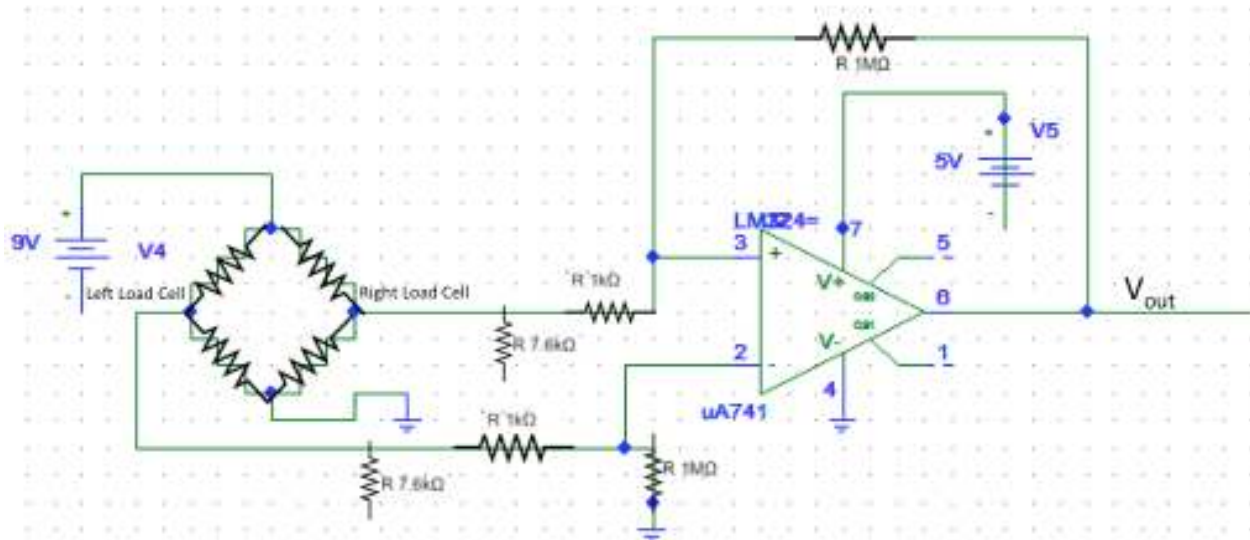

**Figure 10:** This figure depicts the circuit used in the device. The circuitry is powered by a 9 volt battery, contains an Arduino and uses a wheatstone bridge for the load cells.

Numerous steps were taken to ensure accuracy of the weight monitoring system prior to completion of the design. To test the device’s ability to determine the differences in weight distribution between the left and right side, the voltage deflections were monitored as weights were added. Ten weights of 10 pounds were placed in a variety of arrangement on the board starting with first 100 pounds on the left side, then moving 10 pounds to the right side. This was continued until all 100 pounds were on the right side. The voltage output is in a linear to weight distribution, indicating that voltage can be used to assess weight distribution (Figure 11).

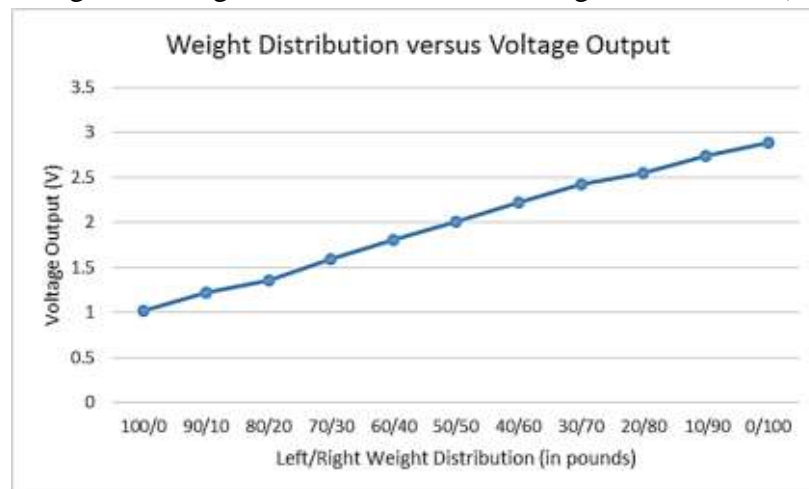

**Figure 11:** This graph displays the relationship between voltage deflection and weight distribution.

## Arduino Microcontroller and Programming:

Interpreting the output signal from the load cells and amplifier will require incorporating a microcontroller within the design. The microcontroller must be capable of reading an analog input, interpreting this signal, and outputting an audio signal in response. It must be possible to power the microcontroller with a battery, such as a 9V battery. Most microcontrollers meet these basic criteria. However, the previous year's design team utilized an Arduino Leonardo microcontroller that can be reused for this design, making this the most economic and immediate solution.

The Arduino Leonardo contains 20 different digital input/output pins, of which 12 of these can be utilized as analog inputs. It can output different frequency audio signals with a built in tone function that can be altered depending on an input signal received by an analog input pin. Also, the board is capable of producing 3.3V and 5V voltage supply outputs via the power pins, which can be utilized to power the circuitry for the load cells and differential amplifier<sup>6</sup>. Finally, the Leonardo is small enough to fit underneath the Health o Meter scale, which satisfies the portability requirement.

Each individual Arduino script is known as a "sketch". Every Arduino sketch contains at least two basic functions: a setup and a loop. Additional functions can be defined later in the code that can be utilized by the setup or loop functions. The setup function is only executed once when the Arduino is first powered on. The loop function is then repeatedly executed once the Arduino finished running the setup.

In the current Arduino code (see Appendix C), the setup function serves to calibrate the load cells, reading the reference voltage three times and then averaging these values. This is done to account for noise that was seen in the signal produced by the load cells. After calculating this reference voltage, voltage boundaries are then established that serve as the thresholds for the different feedback tones that are played. Once the calibration is complete, a short melody is played to alert the user that the device is calibrated. At this point, the loop function begins to execute. Each execution reads the analog pin receiving the load cell output, then executes the playtone function. The playtone function takes the last read voltage input and checks where it fits within the voltage output, and then plays the appropriate tone.

The audio biofeedback tones are set up in order to be as easy to interpret as possible. To start, a measured input voltage within the middle threshold that corresponds to an evenly balanced stance results in the output of a middle C tone (523 Hz). This central tone is special in that it is also a pulse signal; that is, a slow paced beep that alerts the user that they have achieved proper balance. As the voltage increases due to shifting of balance to the right and moves to higher thresholds, the output tone increases to a D and then E (587 Hz and 659 Hz, respectively). As the voltage decreases, the tone decreases to a B and then A (494 Hz and 440 Hz,



respectively). These different tones that correspond to off balance posture are constant tones that when compared to the middle C pulse are easily discernible.

To measure this output from the load cells there needs to be a constant 3V. Initially in the testing of audio output, a USB cord was used to supply the Arduino with power. A problem arose when the Arduino was first attached to a 9V battery. This problem sparked because the 9V battery was insufficiently charged. Since the rest of the circuitry required more power the battery needs to be sufficiently charged to output the necessary voltage. Overall the battery will last approximately 3-4 hrs.

### **Final Design and Fabrication:**

After the circuit was verified to work as intended with the Arduino, a circuit board was soldered and wire wrapped, connecting the differential amplifier as well as the circuitry for the speakers. The connections of the circuit board were tested using the continuity function of a voltmeter to determine that the correct connections were made. Afterwards, a container was made thin enough to fit under the scale so that the Arduino, battery, and the circuit board could be placed within. To ensure that the wires will stay on the Arduino Leonardo, the wires that connects from the circuit board to the Arduino were soldered. The remaining wires were then attached to the scale to reduce wire movement.

To power the Arduino, a 9 V battery was connected to a button switch that allowed easy turning on and off of the device. The Arduino also provides 5 V output for the differential amplifier as well as 3.3 V output for the wheatstone bridge.

To operate the device, the client will place it on a flat surface and press the switch. After 10 seconds, the device will play a short melody indicating that the Arduino has been successfully calibrated. At which point, a pulsating middle C tone will play indicating that the device measures an equal weight distribution (or a lack thereof). The client can now stand on the device to practice her weight distribution. As she leans to the right, the pulsating tone will become constant and increase in frequency in relation to a musical scale, and as she leans to the left, the tone will decrease. She will aim to maintaining weight distribution by having a pulsating tone of middle C. When she is done, she will step off the scale and gently press her foot against the button switch to turn it off.



**Figure 12:** Final prototype design shown.

## Timeline:

To start the project, the month of September was dedicated to literature research. In this period, the focus of the research was to compile information about post-stroke symptoms, weight monitoring systems, and microprocessors. Through October the materials were defined and ordered from the Health-O-Meter company. In addition, the circuitry such as the speaker, switch and wire wrap board were purchased from RadioShack. Manufacturing of the circuit began the week of October 25th, the circuit was planned out and then diagrammed using PSPICE. Manufacturing continued through October and was finalized in November. Determining the mechanism of the load cells was a very time consuming part of manufacture taking over a month. In the period of manufacture, researching load cell mechanisms was a main priority. Testing occurred from November 15 to December 7. Testing focused on both the load cells and the actual prototype. During the first week of December the product was finalized, final testing was completed and the report was written. While the product still requires optimization, the circuit and Arduino code are functional.

| Task                    | September |   |   |   | October |   |   |   | November |   |   |   | December |   |
|-------------------------|-----------|---|---|---|---------|---|---|---|----------|---|---|---|----------|---|
|                         | 6         | 1 | 2 | 2 | 4       | 1 | 1 | 2 | 1        | 8 | 1 | 2 | 2        | 7 |
|                         |           | 3 | 0 | 7 |         | 1 | 8 | 5 |          |   | 5 | 2 | 9        |   |
| <b>Project R&amp;D</b>  |           |   |   |   |         |   |   |   |          |   |   |   |          |   |
| <b>Lit. Research</b>    | X         | X | X | X | X       | X |   |   |          |   |   |   |          |   |
| <b>Manufacturing</b>    |           |   |   |   |         |   |   | X | X        | X | X | X | X        |   |
| <b>Cost Estimation</b>  |           |   |   | X | X       | X | X |   |          |   |   |   |          |   |
| <b>Testing</b>          |           |   |   |   |         |   |   |   |          |   | X | X | X        |   |
| <b>Deliverables</b>     |           |   |   |   |         |   |   |   |          |   |   |   |          |   |
| <b>Progress Reports</b> | X         | X | X | X | X       | X | X | X | X        | X | X | X | X        | X |
| <b>Midsemester</b>      |           |   |   |   | X       |   |   |   |          |   |   |   |          |   |
| <b>Final Poster</b>     |           |   |   |   |         |   |   |   |          |   |   |   |          | X |
| <b>Meeting</b>          |           |   |   |   |         |   |   |   |          |   |   |   |          |   |
| <b>Client</b>           | X         |   |   | X |         | X |   |   |          |   |   |   |          | X |
| <b>Team</b>             | X         | X | X | X | X       | X | X | X | X        | X | X | X | X        | X |

Figure 13: Expected timeline for the duration of the semester. The color represents group expectations each week.

## Future Works:

The current device is functional but could use some changes to the overall design to improve client comfort and simplicity of operation before being sent to the client. One such aspect would be to decrease the overall power consumption of the device, prolonging battery life. Some possible solutions would be to use a different Arduino or microprocessor and a more efficient op amp. To replace the Arduino, the best match for the device would be the Arduino Nano or the Arduino Micro. These smaller devices would reduce power consumption without sacrificing functionality. Not only would these devices reduce power, but they would require a smaller housing for the circuitry, leaving more space under the scale. To decrease the required space and improve durability of the circuitry, the current circuit board could be printed onto a PCB. This can be achieved through the use of the program, PCB Express. Likewise the LM324 quad op amp used in this design is large and consumes more power than necessary. Replacing it with a more efficient op amp would further decrease the power consumption of the device, increasing portability to our client.

Another big problem that needs to be addressed is the volume of the speaker. Currently the device uses an 8 ohm piezoelectric speaker that emits loud enough signals if the room is silent, but if background noise is present the signal may be difficult to hear. This can be fixed by adding an audio amplifier to the speaker which would noticeably increase the volume. A possible alternative to an amplifier is to use a larger speaker or improve the placement of the speaker. Currently, the speaker is underneath the glass surface of the scale

Further changes for the current prototype would be to use a more appealing method to store the circuitry and cover the top glass so that it not visible. The circuitry needs to be placed in container that appropriately holds the wires and is easily mounted to the main body of the device rather than the glass. Likewise, the switch to power on the device needs to be mounted to the body. Also, a different switch should be used, as the current switch is difficult to operate with one's foot. To cover the glass portion a material similar to rubber would be used to prevent slip and conceal the circuitry below. In addition to the covering material, footprints would be placed within the material to optimize the accuracy of each reading.

Future adaptations would include an auto-sleep function for the Arduino, allowing subjects to forego shutting off the device if it is excessively physically demanding. Finally, it would be interesting to establish a method of storing the balance information of each performance in order to track the client's progress and make the device adaptable, decreasing the "balance threshold" as the client improves her posture.

## **Conclusion:**

Audio biofeedback maximizes portability and ease of use of the design for the client's living situation. Observing the variation of pitch will allow the client to know when they are balanced. Providing the client with a balance biofeedback board will hopefully improve the client's ability to balance increasing their mental and physical endurance to perform day to day activities. Eventually a device similar in nature could be broadened to a larger clientele, helping stroke victims practice weight distribution with a portable, user-friendly device.

## **Acknowledgements:**

The Balance Biofeedback design team would like to acknowledge their advisor Dr. Thomas Yen for challenging the team to create a serviceable balance device for the client by bringing support and enthusiasm throughout the design process. The team would also like to thank Dr. Willis Tompkins for stepping in for Carol Rohl as the client and providing insight and needed specifications for the design. Thanks are also extended to Carol Rohl for presenting the group with this project and relaying to the group her aims. Lastly, the team would like to express gratitude to the Biomedical Engineering Department of the University of Wisconsin - Madison for providing facilities, equipment, and resources.

## References:

1. Donnan GA, Fisher M, Macleod M, Davis SM. Stroke. *The Lancet* 2008; 371(9624):1612-23.
2. Sims NR, Muyderman H. Mitochondria, oxidative metabolism, and cell death in stroke. *Biochim Biophys Acta* 2010; 1802(1):80-91.
3. Ramas J, Courbon A, Roche F, Bethoux F, Calmels P. Effect of training programs and exercise in adult stroke patients: literature review. *Ann Readapt Med Phys* 2007; 50(6):438-44.
4. Thelen D, Decker C. BME 315 Biomechanics: Human Postural Balance and jumping: Forceplate Analysis. 2013.
5. Chaudhry H, Findley T, Quigley K, Bukiet B, Ji Z, Sims T, Maney M. Measures of Postural Stability. *JRRD* 2004; 41(5):713-720.
6. "Arduino - ArduinoBoardLeonardo." Arduino - ArduinoBoardLeonardo. N.p., n.d. Web. 11 Dec. 2013.
7. "A Primer on the Design and Use of Strain Gage Force Sensors." Interface Inc., n.d. Web. 11 Dec. 2013.

**APPENDIX A:**  
**Design Contact Information**

**Client:** Professor Willis J. Tompkins, Ph.D [wjtompk1@wisc.edu](mailto:wjtompk1@wisc.edu)  
Carol Rohl [carol@gordonbok.com](mailto:carol@gordonbok.com)

**Advisor:** Thomas Yen, Ph.D [yen@engr.wisc.edu](mailto:yen@engr.wisc.edu)

**Team:** Xiyu (Steve) Wang [xwang332@wisc.edu](mailto:xwang332@wisc.edu) (Team Leader)  
Dalton Hess [dhess2@wisc.edu](mailto:dhess2@wisc.edu) (Communicator)  
Kiersten Haffey [haffey@wisc.edu](mailto:haffey@wisc.edu) (BSAC)  
Andrew Vamos [vamos@wisc.edu](mailto:vamos@wisc.edu) (BWIG)  
Jacob Hindt [jhindt@wisc.edu](mailto:jhindt@wisc.edu) (BPAG)

## **APPENDIX B:**

### **Additional Pictures**

The figure below depicts the original circuit board used in the Health-O-Meter HDL645KD-63 Glass Digital Scale. The red and black wire present at the top of the circuit board were used to for switching the units of weight, therefore that part of the circuitry was excluded.

**Figure 14:** This was the original circuit board used within the scale.

**Figure 15:** An isolated load cell



**Figure 16:** Wheatstone bridge, differential amplifier, and Arduino circuitry during testing

## **Appendix C: PDS**

### **Design of weight distribution monitoring system**

10/9/2013

**Group Members:** Kiersten Haffey, Dalton Hess, Jacob Hindt, Andrew Vamos, and Xiyu (Steve) Wang

**Advisor:** Dr. Thomas Yen

**Client:** Dr. Willis Tompkins representing Carol Rohl

**Function:** Stroke is a major issue in the United States with more than 800,000 yearly occurrences and 133,000 deaths every year. Many stroke survivors experience brain damage that can leave their body permanently injured. A hemiplegic individual who suffered a stroke five years ago lost all sensation on her left side of the body. She is ambulatory but suffers from improper gait and standing positions due to her left side. We are working on a portable device that will allow her to practice how it feels to stand with proper weight distributions. We hope that by practicing with our device, our client will be able to improve her walking and improve her overall quality of life.

#### **Client Requirements:**

- The client must be able to carry the device in one hand for convenience and portability
- The device must be thin, so that the client can easily step onto the device. Thickness of a scale is the maximum thickness desired.
- The device must not require the client to look downwards or hold a light display, which causes error in weight distribution balance.
- The device must not have a hand-held device.
- The device must not contain any hinges or metal parts that may damage flooring

#### **Design requirements:**

##### **1. Physical and Operational Characteristics**

- a. Performance requirements: The device must be able to perform numerous tests with up to 800 N of force.
- b. Safety: The device should be constructed so that the client will be able to stand and balance easily without any risk of falling or other harm.

c. Accuracy and Reliability: The device should be accurate enough to discern changes in weight distribution but not too precise as the body is never in rest, even when standing. A threshold of 10% will be adapted to allow the client to practice weight distribution.

d. Life in Service: The device will be operated on the timescale of half-hours and at a maximum an hour. It should not consume an excessive amount of power, as batteries can be costly to the client. The batteries will be replaceable when exhausted.

e. Shelf Life: The device must be able to be stored and easily retrieved for further use over a period of at least a year.

f. Operating Environment: The client intends to use the device in standard living environments with chances of humidity or other weather effects. The device will be used on a flat surface and at room temperature.

g. Ergonomics: There should be minimal interaction required by the client while attempting to measure her weight distribution. It should be simple to use and easily understood.

h. Size: The device must be portable - small enough so that the client can take it with her and use it in places other than her residence. Additionally, it must be thinner than 5 centimeters, as the client struggles to lift her impaired leg off of the ground.

i. Weight: The device must be light enough to maintain portability.

j. Materials: The materials must be lightweight yet durable enough to withstand the clients weight. Possibility of integrating commercial bathroom scale.

k. Aesthetics, Appearance, and Finish: The device should provide clear and easily interpreted feedback for the client. The body of the device will be compact and have no external parts that could cause safety issues.

## **2. Production Characteristics**

a. Quantity: There must be at least one device fabricated

b. Target Product Cost: Price is not an issue for this device.

## **3. Miscellaneous**

a. Standards and Specifications: The device will be less than 5 centimeters thick and weigh less than 5 pounds. The device must be IR approved.

b. Customer: The device is being created for one specific client, however, there could be a potential market for this device.

c. Patient-related concerns: The client is unable to lift her left leg up very high so extra precautions will be taken to make sure that our device is low enough for her to conveniently get on and off. Additionally, looking downwards towards her feet causes the client to lose her balance.

d. Competition: Similar products have been designed to measure a person's weight distribution. The Wii Balance Board has been proven to be extremely effective in assessing weight distribution. It utilizes four force sensors to calculate the center of a given weight distribution. However, the client considers this device to be bulky as well as too tall.

Clinically, a few devices are used. One common clinical device the SMART Balance Master® provides balance retraining in a box-like device on an 18" by 18" forceplate through visual feedback on either a stable or unstable support surface and in a stable or dynamic visual environment. However the device costs \$90,000.

Other clinical devices such as AMTI OR6-6 force plate uses auditory biofeedback . However this system interfaces with a laptop computer to acquire signals from the sensor and generate a stereo sound providing body-sway information.

#### Works Cited

<http://www.sciencedirect.com/science/article/pii/S000399930500211X>

<http://resourcesonbalance.com/neurocom/products/SMARTBalanceMaster.aspx>

## Appendix D:

### Arduino Code:

```
int backPin = A1; // UPDATE
int backVal ; //Holds voltage from Back input
int backVal1; //First calibration voltage value
int backVal2; //Secon calibration voltage value
int backVal3; //Third calibration voltage value

/* Set calibration boundaries, if not updated with each use:
double max_1 = 1.635
double bound_2 = 1.535
double bound_3 = 1.435
double bound_4 = 1.335
double bound_5 = 1.235
double mid_6 = 1.135
double mid_7 = 1.035
double bound_8 = 0.935
double bound_9 = 0.835
double bound_10 = 0.735
double bound_11 = 0.635
double bound_12 = 0.535
*/

double bound_high1; //Establish decimal numbers pitch boundaries
double bound_high2;
double bound_low1;
double bound_low2;
double backVolts;

#include "pitches.h" //Loads the pitches.h file witch contains the notes for the intro melody
(from Arduino website)

// notes in the melody:
int melody[] = {
  NOTE_C4, NOTE_G3,NOTE_G3, NOTE_A3, NOTE_G3,0, NOTE_B3, NOTE_C4};

// note durations: 4 = quarter note, 8 = eighth note, etc.:
int noteDurations[] = {
  4, 8, 8, 4,4,4,4,4 };
```

```

//////////BEGIN SETUP//////////
void setup() {
  Serial.begin(9600); //set baud rate. default=9600
  int opAmpPin = 13;
  pinMode(opAmpPin, OUTPUT);
  digitalWrite(opAmpPin,HIGH);
  int wheatstonePin = 12;
  pinMode(wheatstonePin, OUTPUT);
  digitalWrite(wheatstonePin,HIGH);

  backVal1 = analogRead(backPin); //Reads initial load cell output 3 times for calibration
  delay(500);
  backVal2 = analogRead(backPin);
  delay(500);
  backVal3 = analogRead(backPin);

  backVal = (backVal1 + backVal2 + backVal3)/3; //Averages 4 load cell outputs

  backVolts = backVal * 0.0049; //Converts to voltages for easier interpretation via Serial Monitor

  bound_high2 = backVolts + 0.15; //Establish 4 thresholds for 5 tones
  bound_low1 = backVolts - 0.15;
  bound_high1 = backVolts + 0.45;
  bound_low2 = backVolts - 0.45;

  //play melody to alert user that it is ready (not necessary)
  for (int thisNote = 0; thisNote < 8; thisNote++) {

    // to calculate the note duration, take one second
    // divided by the note type.
    //e.g. quarter note = 1000 / 4, eighth note = 1000/8, etc.
    int noteDuration = 1000/noteDurations[thisNote];
    tone(10, melody[thisNote],noteDuration);

    // to distinguish the notes, set a minimum time between them.
    // the note's duration + 30% seems to work well:
    int pauseBetweenNotes = noteDuration * 1.30;
    delay(pauseBetweenNotes);
    // stop the tone playing:
    noTone(10);
  }
}

```

```

}

delay(500);
}

//begin loop for main function
void loop() {

backVal = analogRead(backPin); //read back voltage

playtone(backVal); //Send current backval reading to playtone function
delay(100); //Slight pause in reading to avoid noise
}

//playtone function for interpreting voltage sources and playing according tone
void playtone (double backVal) {
  backVolts = backVal * 0.0049; //converts backVal into voltages
  //Serial.print(backVolts); //enable this for troubleshooting input signal via serial monitor
  if(backVolts > bound_high1){ //checks first bound
    tone(10,659);}
  else if(backVolts > bound_high2){ //if not first bound, check second bound...etc.
    tone(10,587);}
  else if(backVolts > bound_low1){
    tone(10,523);
    delay(250); //delays for pulse tone of middle range
    noTone(10);
    delay(100);}
  else if(backVolts > bound_low2){
    tone(10,494);}
  else {
    tone(10,440);}
}

```

**APPENDIX E:**  
**Materials**

| <b>Material</b>                                | <b>Cost</b>    |
|--|----------------|
| Health o Meter HDL645KD-63 Glass Digital Scale | \$29.99        |
| Arduino Leonardo                               | \$24.95        |
| Push-Button with Red LED                       | \$6.99         |
| 8 Ohm Mini-Speaker                             | \$3.99         |
| Printed Circuit Board                          | \$2.49         |
| 9 V Battery                                    | \$1.99         |
| Resistors                                      | n/a            |
| Storage Container                              | n/a            |
| <b>Total Cost</b>                              | <b>\$70.40</b> |