

# **Laryngeal Perfusion Decellularization- Recellularization Bioreactor**

**Biomedical Engineering Design 400  
Fall 2013**

**Team:**

**Kyle Anderson: BWIG, BPEG**

**Peter Guerin: BSAC**

**Daniel Thompson: Team Leader**

**Rebecca Stoebe: Communicator**

**Client:**

**Dr. Nathan Welham, PhD, CCC-SLP**

**Dr. Yutaka Toya, MD, PhD**

**Advisor:**

**Dr. Tracy Puccinelli, PhD**

## **Abstract**

The global population encounters disease of vital tissue and organs at an increasing rate every year. Tissues can be completely destroyed or only moderately impaired by these diseases, resulting in loss of function. These damaged tissues cannot typically regenerate, leading to the need for a transplant. Multiple problems can occur through the transplantation process: such as finding a donor, immune system rejection, biocompatibility, functionality, and lack of growth or remodeling. However, recent research in the field of tissue engineering has provided a hope for generating vital tissues. Through the process of decellularization-recellularization, the donor's cells can be used to generate a new, fully functional organ. This process has been completed with other organs such as the lungs, heart, trachea, and kidney and shows that this technique is viable. Our client would like to construct a larynx using the decellularization and recellularization process. The main components that are vital to the regeneration of the larynx are a bioreactor that is congruent with the organ, and the ability to produce different environments for different sections of the larynx. The decellularization-recellularization process for the larynx needs these components to be optimized to generate a fully functional organ. Our final design includes a rectangular bioreactor that holds the larynx horizontally and is equipped with a motor that is capable of turning the organ, providing all cells access to both air and media, and a cage-like enclosure to secure the larynx. In the future, we will be fabricating this design, testing fluid flow rates through the device and into the organ, and assessing its capability to adequately de/re-cellularize an organ.

# Table Of Contents

<b>Problem Statement.....</b>	<b>3</b>
<b>Project Motivation.....</b>	<b>3</b>
<b>Background.....</b>	<b>4</b>
<b>Client Background.....</b>	<b>4</b>
<b>Laryngeal Anatomy and Physiology Background.....</b>	<b>4</b>
<b>Tissue Engineering Background.....</b>	<b>6</b>
<b>Product Design Specifications.....</b>	<b>7</b>
<b>Existing Products.....</b>	<b>8</b>
<b>Previous Work.....</b>	<b>9</b>
<b>Component Design.....</b>	<b>10</b>
<b>Design Alternatives.....</b>	<b>11</b>
<b>Design Alternative One: Mesh.....</b>	<b>11</b>
<b>Design Alternative Two: Cage.....</b>	<b>13</b>
<b>Design Alternative Three: Operating Table.....</b>	<b>14</b>
<b>Design Matrix Analysis.....</b>	<b>15</b>
<b>Final Design.....</b>	<b>16</b>
<b>Budget.....</b>	<b>16</b>
<b>Ethics.....</b>	<b>17</b>
<b>Future Work.....</b>	<b>17</b>
<b>Acknowledgements.....</b>	<b>18</b>
<b>References.....</b>	<b>19</b>
<b>Appendix.....</b>	<b>21</b>
<b>PDS.....</b>	<b>21</b>
<b>Timeline.....</b>	<b>24</b>

## **Problem Statement**

Dr. Nathan Wellham and his colleagues are currently researching the larynx and the optimal way to create a fully functional organ by utilizing the decellularization-recellularization process. Our purpose is to design a laryngeal bioreactor that accomplishes this technique. Previously, a UW BME 400 team designed a bioreactor that can decellularize a larynx, but did not complete testing on the recellularization process. Before moving forward the client would like aspects of the past bioreactor changed in order to make a more optimal product for the recellularization process. Among his requests were that the bioreactor to be horizontal during the experiment, the design allows easy access to air as well as media, and the design allows easy access to catheters that are supplying fluid to the vasculature. This semester, the team is focusing on building a design that meets the requests of the client, while also implementing other design considerations. Additionally, the team seeks to incorporate and build upon the automation system that the previous team began implementing into the design.

## **Motivation**

The need for organ replacement has grown in prominence over the last fifteen years. Wait lists for organs often exceed the donor rate tenfold (1). As the baby boomer generation reaches retirement, this need will become even more apparent. Patient need for organs varies from tissue to tissue. Specifically for the larynx, laryngeal cancer affects 136,000 individuals worldwide each year, and a majority of these patients require a partial or total removal of this organ to stop the spread of cancer (2). After this surgery, patients may be mute, and may have to breathe through a stoma, or an artificially created hole in the neck. Stomas can be problematic to users, as they require changes in patient daily activities such as speaking, showering, and even sleeping in order to accommodate breathing through the stoma (3).

Theoretically, after a laryngectomy a patient could have a laryngeal transplant in order to avoid many of the problems listed above. However, at present, there have only been two successful cases of full laryngeal transplant. This is due, in part, to complexities associated with the surgery itself, and also in part due to anatomical complexities that lead to a patient mismatch in tissue (2, 4, 5). Additionally, patients that receive an allograft larynx transplant must live with the risk of tumor recurrence, metastasis, and multi-infection as well as facing lifelong immunosuppression (2). Researchers have suggested that decreasing the immune response of the implantation by using the patient's own mesenchymal stem cells to generate an organ could clear up many of the problems currently associated with laryngeal allografts (2). To date, there have not been published studies of entire larynges being grown *in vitro*, however, there has been at least one successful case of tracheal cartilage being grown *in vitro* and successfully implanted in a patient (6). Thus, the success of this project could prove to be a major step in the treatment of laryngectomies for laryngeal cancer patients.

## Background

### **Client Background**

Dr. Nathan Welham is an Assistant Professor at the UW School of Medicine and Public Health in the Division of Otolaryngology-Head and Neck Surgery. Clinically, Dr. Welham is an expert in speech-language pathology and the treatment of patients with disorders of the voice, resonance, swallowing and airway disorders. He practices in the Voice and Swallowing Clinic, both adult and pediatric, at UW Health. In addition, Dr. Welham has had extensive research experience. He has over 30 citations on PubMed and has most recently published papers on proteome analyses and treatment of sulcus vocalis. He also developed animal models to help the UW School of Medicine study vocal fold scarring.

### **Laryngeal Anatomy and Physiology Background**

The larynx is an organ that functions as a crucial part of the respiratory system. It is located in the anterior portion of the neck, ventral to the esophagus. The larynx connects the pharynx to the trachea and ultimately the lungs. Besides this role, the larynx has two other physiological functions. First, the epiglottis, located at the superior end of the organ, folds over the larynx during swallowing to prevent food from entering the lungs. Additionally, the vocal cords are located in the larynx, and it is their movement, when pulled taut and when air passes over them that produces sound and provides the basis for phonation (7). Figures 1 and 2 below show the gross exterior and interior anatomical structures of the larynx, which are discussed in the succeeding paragraphs.

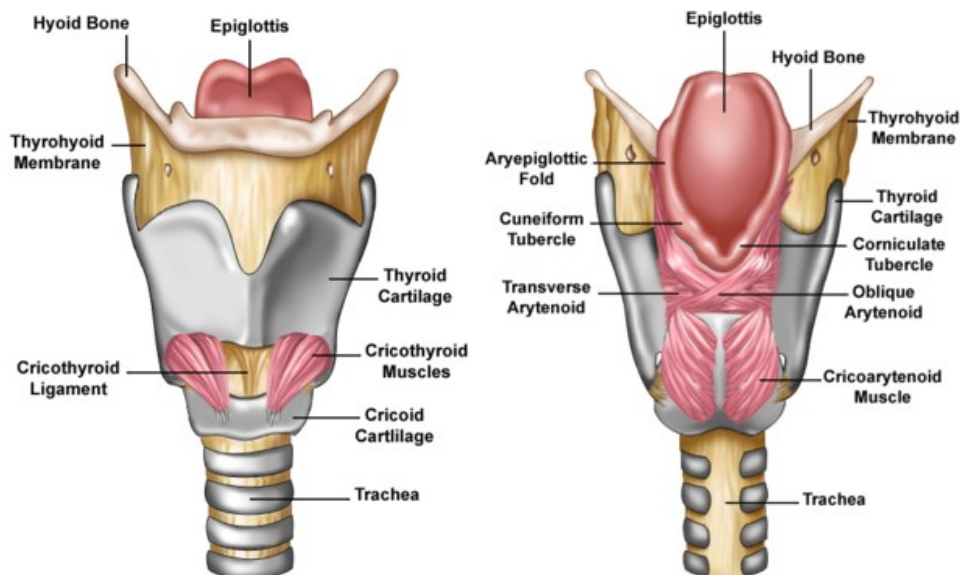

**Figure 1: External ventral (left) and dorsal (right) gross laryngeal anatomy (8)**

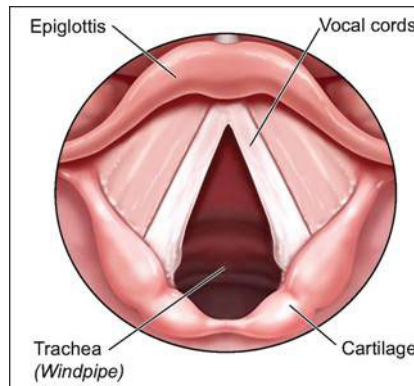

**Figure 2: Internal gross laryngeal anatomy (9)**

As can be seen from figure 1 above, the larynx is composed of several different tissue types, including cartilages, muscles, ligaments, and adipose tissue. This organ is bordered on the superior end by the hyoid bone (which does not form part of the organ itself) and on the inferior end by the trachea, which is also not part of the organ. The larynx is supported by 6 cartilages: 3 single cartilages which are, in descending order, the epiglottic, the thyroid, and the cricoid cartilage, and 3 paired cartilages which are, in descending order, the cuneiform, the corniculate, and the arytenoid (not pictured) cartilages (7). The larynx also has three major muscle groups:

- 1) the circothyroid muscles, located near the cricoid cartilage help to control pitch of the sound produced by the vocal cords
- 2) the circoarytenoid muscles, located near the cricoid cartilage, help to rotate the cartilage and adduct the vocal cords to produce lower pitched sounds or to relax the vocal cords
- 3) the arytenoid muscles, located near the arytenoid cartilages, rotate the arytenoid cartilages inward and tighten the vocal cords (7).

The vocal cords are formed by a membrane known as the conus elasticus that attaches to the anterior cricoid cartilages inferiorly and to the thyroid cartilage as well as the arytenoid cartilages superiorly. The free superior end of this membrane is what vibrates to produce sound (10). An illustration of the vocal cords can be seen in figure 2 above.

The tissues of the larynx are highly vascularized; they are supplied by the superior and inferior laryngeal arteries. The superior laryngeal artery stems from the common carotid artery whereas the inferior laryngeal artery stems from the subclavian artery. Similarly, the larynx is drained by the superior and inferior laryngeal veins which both eventually drain into the brachiocephalic veins (7). The arterial blood supply is shown in figure 3 below.

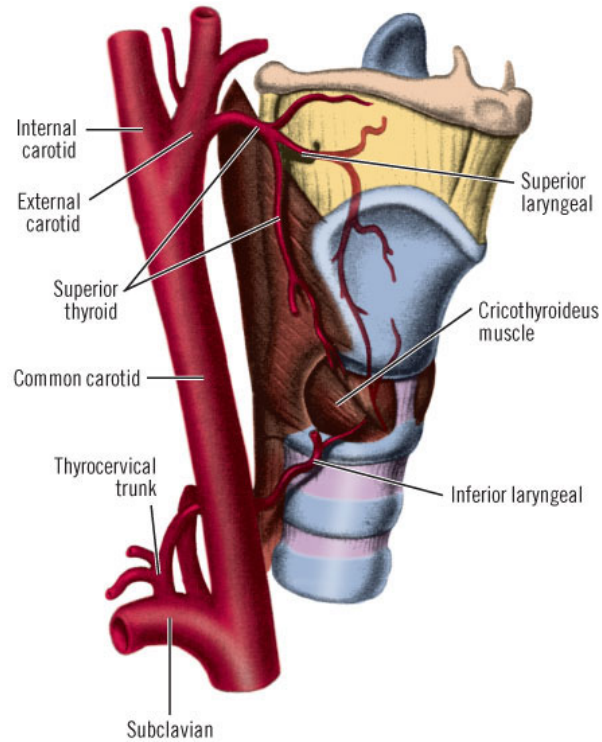

Copyright ©2006 by The McGraw-Hill Companies, Inc.  
All rights reserved.

**Figure 3: Arterial blood supply in the larynx and surrounding tissues (11)**

### **Tissue Engineering Background**

Within the last 20 years, tissue engineering has become an area of enormous development and research within the field of biomedical engineering. This project is based on stem cell engineering, which is a subset of tissue engineering. Stem cells differ from most cells in their ability to differentiate into multiple types of cells (12). Embryonic stem cells have the ability to differentiate into nearly every cell type, which, during development, gives rise to all of the different tissues within the body (12). Adult stem cells, which are the types of cells used in this method of organ regeneration, have the ability to differentiate into multiple cell types based on their location within the adult body (12). Additionally, throughout life these adult stem cells serve as an internal repair system, replacing dead or damaged cells. This ability to differentiate into many different tissues makes stem cell engineering an area of great interest to biomedical engineers for the treatment and cure of diseases.

This project focuses on the creation of a bioreactor that has the ability to decellularize and recellularize a larynx. Decellularization implies that all cells are removed from a whole donor organ via detergents, leaving only a viable extracellular matrix (ECM). This ECM is then repopulated with healthy adult stem cells taken from the patient that will ultimately receive the tissue, which is termed recellularization (13). As the process of decellularization and recellularization cannot be performed in vivo, a bioreactor can help to construct an ex vivo environment that encourages cell growth and differentiation (13). Therefore, the purpose of a bioreactor is to create a controlled

environment that has the ability to simulate physiological conditions. The growth and differentiation of stem cells is highly dependent on the environment in which the cells are seeded in, and thus seeding stem cells in an environment that is similar to a native environment of the target tissue, will, theoretically, encourage these cells to differentiate into the target tissue (13). The process of decellularization and recellularization is illustrated in figure 4 below.

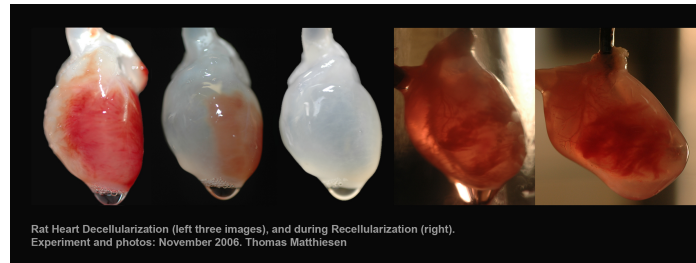

**Figure 4: Decellularization (left 3 images) and recellularization (right 2 images) of a rat heart (14)**

### **Product Design Specifications**

The final product must be able to first decellularize a human, pig or dog larynx. The bioreactor must create an acellular scaffold before recellularization can begin. After this has been accomplished it needs to be capable of repopulating the scaffold with new donor specific cells. This must be accomplished without the tubes or inlets connected to the larynx loosening from their attachment points. The recellularization of a larynx can take up to three weeks, and needs to be performed not only on a lab bench but also in an incubator or refrigerator. For this reason the materials for the design must take the temperature and humidity of these diverse environments into consideration. The materials must not wear down for several months or the course of a full experiment with multiple larynges.

The bioreactor will be taking up space in the lab for several months so it must be small enough to not take up a large amount of room on a lab bench, but large enough to house a human, pig, or dog larynx, which can measure up to 6 cm in length (15). The user must be able to easily place the larynx inside the bioreactor along with enough space to make any adjustments needed. Additionally, the inside of the bioreactor must be small in order to conserve the use of media, as media is the most expensive component of the product, costing about \$400 for 500 mL.

The device will be in contact with chemicals for the full duration of the experiment, so chemical exposure to the user and chemical wear to the device must be taken into consideration. The bioreactor must be airtight in the sealed areas in order to prevent leakage of chemicals and provide a clean environment for the decellularization and recellularization processes. To achieve a clean environment the device must also be autoclavable to provide easy sterilization for multiple uses.

The bioreactor must also function to rotate the larynx to expose it to media and air. A device is to be programmed to rotate the larynx at a rate between 1 rotation per ten minutes and 1 rotation per hour. These rotations must be accurate within ten degrees of the desired orientation to provide homogeneity in the experiment.

The prototype must be completed in a budget of \$3000. The prototype must also be able to function in conjunction with the previous team's purchased media pumps. Finally, the bioreactor must be able to be modified in the future to accommodate other experiments.

### **Existing Products**

The use of a bioreactor for decellularization and then recellularization of tissue is a relatively common tissue engineering practice. This method has been applied to a variety of whole organs, including the heart (16), the lungs (17), and the liver (18). Additionally, parts of the larynx have been made using this method as well. Laryngeal folds have been grown in a bioreactor and have been shown to properly be able to withstand stresses similar to those seen in a biological environment (19). Finally, a trachea has also been grown in vitro using this method and implanted in a patient (20). The trachea, though not a part of the larynx, exhibits related anatomical structure to the larynx, including an inner lumen through which air flows.

Most bioreactors designed for whole organ growth feature one closed container in which media surrounds the tissue. Various tubes allow the exchange of media as well as allow for ventilation. Often these tubes are connected to a media reservoir, and allow for the perfusion of media out of the reactor and then back to the tissue. This concept is illustrated in figure 5 below. The tracheal bioreactor differs from this basic setup and takes advantage of the inner lumen in the design. In the tracheal bioreactor, a rod secures the trachea at either end and a tube enters the trachea from one end to allow media to enter the inner lumen. A motor secured to one end of the rod allows for the rotation of the trachea. This allows cells on any side of the trachea to be exposed to either media or air, depending on the desire of the researchers. This bioreactor is illustrated in figure 6 below.



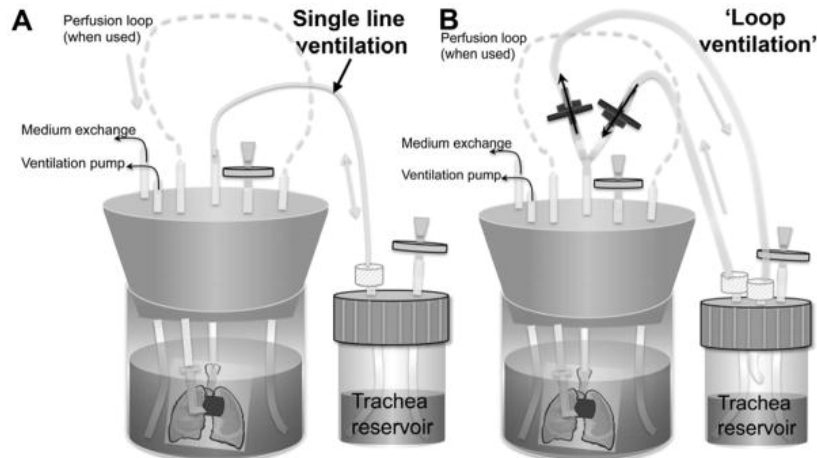

**Figure 5: Lung bioreactor system: Closed jar with tubes entering and leaving bioreactor provide tissue access to medium and ventilation (17)**

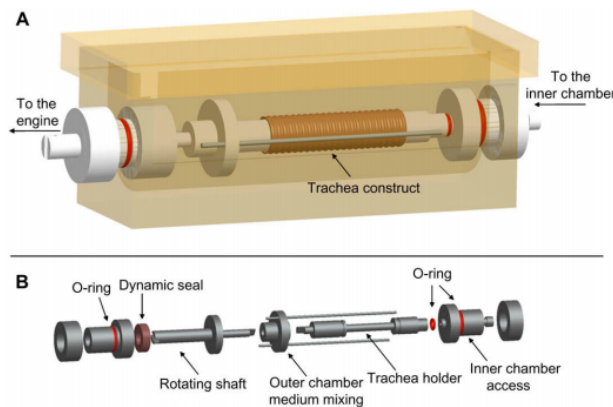
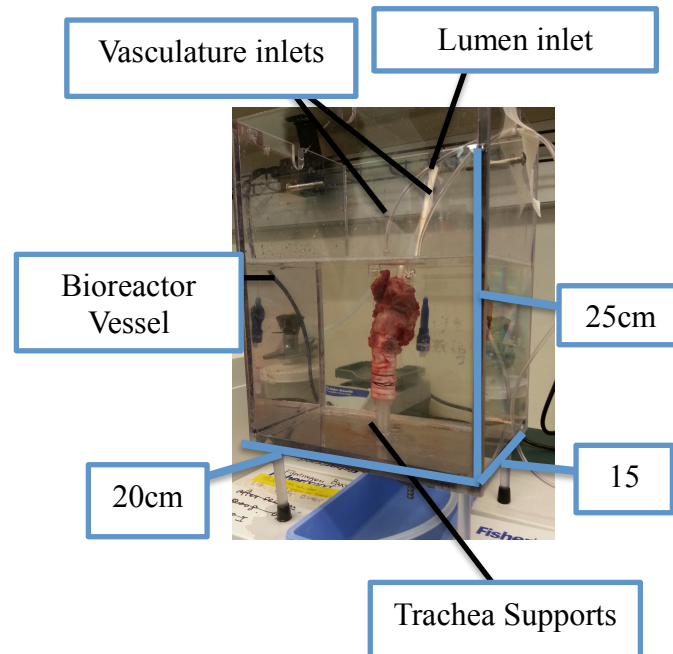

**Figure 6: Rotating tracheal bioreactor: Rod entering the trachea from either end provides structural support and different media access for the interior of the trachea. This rod also is turned by a motor (20)**

### Previous work

Previously, a design team in the Biomedical Engineering Department at the University of Wisconsin-Madison undertook the challenge of designing a bioreactor specifically for the larynx. The team constructed a vertical rectangular bioreactor that utilized natural forces to aid in the reconstruction of the larynx. The larynx was positioned vertically in a polycarbonate bioreactor to mirror an anatomical position of the organ. Gravity was used to drain the inner lumen of the larynx, while negative pressure in the vasculature was used to pump media into the larynx. The team also employed the use of automated perfusion pumps to deliver media to the different areas of the organ. This design can be seen in figure 7 below. This team successfully completed testing of decellularization of the larynx, however the client saw possible areas of improvement in the bioreactor, and desired a complete redesign of the device. First, the design constructed by the previous team was found to be too large, and had dimensions that were not conducive to attaching the larynx. Second, the device did not allow the cells to access

both air and media without completely draining the system. To improve upon these design issues, the client specifically requested a bioreactor that holds the larynx in a horizontal position be constructed.



**Figure 7: Previous bioreactor designed by BME design team: Bioreactor and trachea supports hold larynx vertically, while lumen and vasculature inlets perfuse media through the organ**

### Component Design

Before designs of the full device were created, the team discussed the design of several components of the device. The most notable of these was the design of the turning mechanism for the device. The client specifically requested that the bioreactor be able to turn the larynx, thus exposing all cells in the device to air and media at different points in time. However, turning the larynx presents complications to the design, as tubes that lead to and from the organ can become tangled when the organ is turned.

Two design alternatives were created to attempt to overcome this problem. The first deemed the hot-dog-turner alternative, features tubes that pass through a track cut into a large knob attached to the end of the rod holding the larynx. In this design, the tubes will not move as the rod rotates the larynx completely at a time designated by the user. The second design, termed the stepper/servo motor alternative, features the larynx connected to a rod that can only be turned 90 degrees in any one direction (or 180 degrees total). This amount of rotation would expose all cells to both media and air, but would prevent tube tangling because the rod cannot complete a full rotation.

These two design alternatives were compared using a simplified design matrix, and the stepper/servo motor option received the highest rating due to its high specificity, or ability to control which cells are exposed to air and which are exposed to media, as

well as its higher feasibility, as fewer custom parts will need to be fabricated for the creation of this design.

**Design Alternatives**

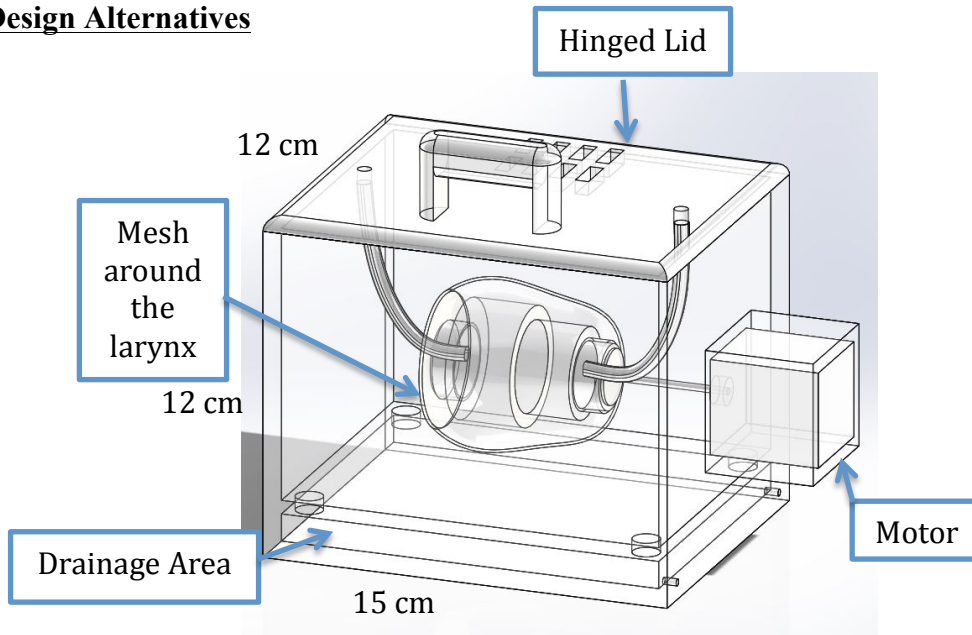

**Figure 8: Design Alternative 1 – A plastic mesh covers the larynx and is attached to a stepper motor. Endotracheal and catheter tubes enter the device through holes in the lid, and separate slits allow air to penetrate into chamber.**

**Design Alternative One: Mesh Design**

The first bioreactor design consists of a 12 cm wide by 12 cm high by 15 cm long box with a hinged lid. The box is made out of polycarbonate that is 0.5 cm thick. These dimensions were chosen to decrease the cost of the use of the bioreactor versus the use of the previous design. As shown below, these dimensions reduce the volume of media used by up to 71% versus the previous design. This decrease will also result in a corresponding decrease in cost per experiment.

**Table 1: Size comparison of the previous team’s design to the new design**

Design	Height (cm)	Width (cm)	Depth (cm)	Volume of Media needed to fill Device (cm <sup>3</sup> )
Previous (without inserts)	25	15	20	7500
Current	12	12	15	2160

The hinged lid is designed with eight air holes to allow movement of air during recellularization and decellularization. The lid is on hinges that ensure that the lid is never misplaced and is always positioned correctly. Also, because the lid is removable, it allows easy access to the inside of the bioreactor. Easy access is important for placement,

removal, and adjustment of the larynx and other internal features. The lid has a handle so that it can be pulled up by the researcher.

In the bottom three cm of the bioreactor there is a drainage area that is connected to the main area via drainage holes. The drainage area has a hole in the side of the bioreactor that connects to one of the pumps, which allows for the change of inner media. This pump will connect back to the top of the bioreactor to allow flow and recycling of the inner media.

The lumen of the larynx needs separate media that is constantly flowing. This design addresses this issue by including a tube that runs through the center of the larynx. This tube connects back up on both ends to the top of the lid and then to the second pump, enabling the constant flow of media. The section of the tube inside of the larynx itself will have slits or holes (depending on flow testing) that allow the media to perfuse through the inner lumen. This tube also has the additional function of providing structural support.

The main feature of this design that differentiates it from the other alternatives is a polymer mesh. This mesh surrounds the larynx, provides support, and enables the perfusion of media in and out. The mesh would be made out of high-density polyethylene or another suitable polymer. The mesh would be stiff enough to provide structural support, while also form-fitting the larynx. The mesh would scrunch up to the right of the larynx around a metal washer. To put the larynx in the mesh you would hold the larynx in place and then slide the mesh around the larynx. The metal washer on the right side of the mesh interfaces with the motor.

On the right side of the bioreactor there will be a 4x4x4 cm cube that houses the motor to control rotation of the mesh and larynx. The motor will be a servo or stepper motor. These motors allow fine angular control of rotation and can be controlled via basic programs and electrical work that could potentially be housed next to the motor. The motor could connect to a LCD screen, so the researcher has full control of the motor at the touch of a button. The full design can be referenced in figure 8 above.

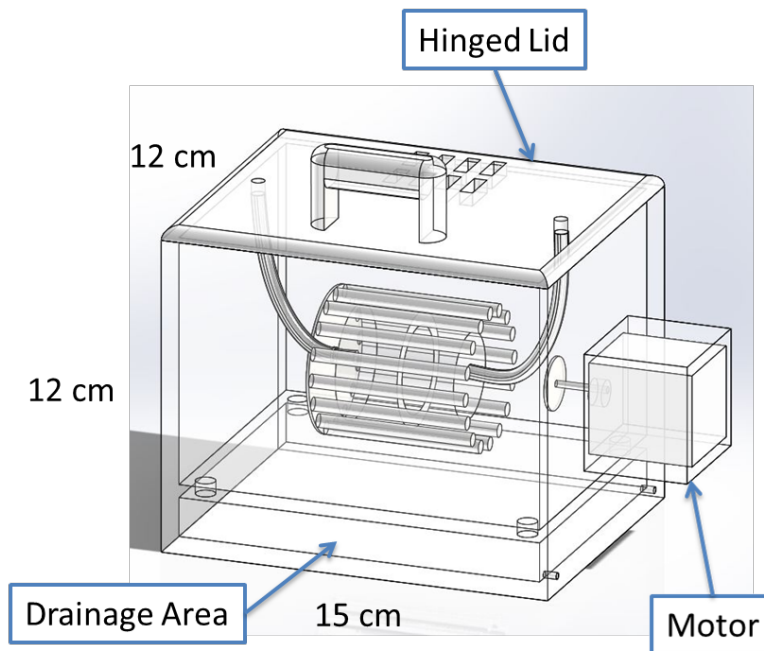

**Figure 9: Design Alternative 2 – A cage attached to the motor surround the larynx. Tubes enter the device through the lid, drainage occurs through outlets at the bottom.**

### **Design Alternative Two: Cage Design**

The second design alternative features the same lid, 12x12x15 cm box size, motor, and drainage area as the first design alternative. This design can be seen in figure 9 above.

The differentiating aspect of this design is the cage component. The cage is made out of firm plastic rods that are attached to each other via a circular plate on both ends (only the left one is pictured in the image). This plate connects to the motor and enables the rotation of the cage and larynx. Because, the cage only rotates 90 degrees in each direction (clockwise and counter clockwise), the cage doesn't rotate a full 360 degrees, thus avoiding tangling of the tubes. The device will be set up so that there is enough slack in the tubes delivering media so that these can be rotated with the larynx. Additionally, there is a gap on the top of the cage that allows the inner lumen tubes to go through to the top of the bioreactor. The cage design provides support to the larynx and the gaps between the cage bars allow free movement of the media in and out of the cage.

The cage is not as flexible as the polymer mesh and therefore is not as form fitting, so the larynx will be sutured to the cage with loops in two locations. This will keep the larynx in line with the cage as the motor rotates it and prevent extra movement of the larynx in the cage. Additionally, cage bars on the top of the larynx (from the 10 o' clock position to the 2 o' clock position) will be made to be removable so that the user can easily reach inside the cage from the top of the device to attach or adjust the organ.

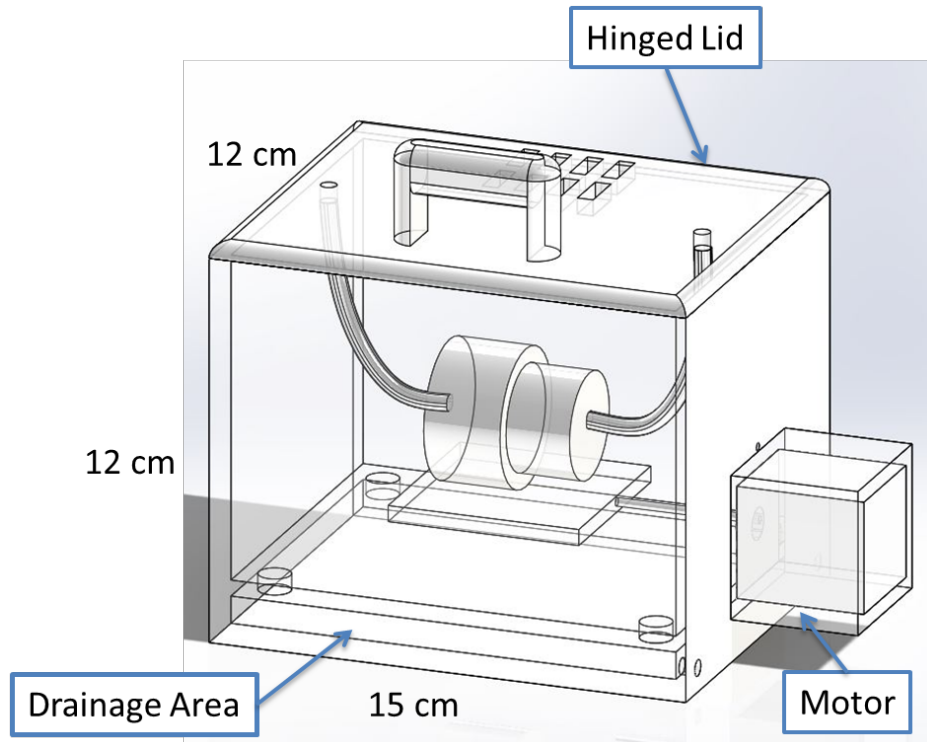

**Figure 10: Design Alternative 3 – The larynx is pinned to a plastic table attached to the stepper motor. An additional rod is used to support the weight (not shown).**

### **Design Alternative Three: Operating Table**

The third design alternative features the same lid, 12x12x15 cm box size, motor, drainage area, and inner lumen tubes as the first design alternative. This design alternative, described below, can be seen in figure 10 above.

This design is set apart by the platform rotation mechanism, upon which rests the larynx. The larynx is pinned in four places to the platform, which has little screws on the corners to anchor the pins in place. The platform itself would be made out of polycarbonate. On the right side of the platform a rod connects the motor to the platform. This rod, when rotated by the motor, would tip the platform from side to side and along with it the larynx. The motor will only allow 90-degree rotation in each direction of the platform. This ensures that every cell is covered by media half the time and prevents the tubes from tangling. The platform has another rod extending from the left side that connects to the side of the bioreactor and provides additional support.

## Design Matrix Analysis

**Table 2: Design matrix for the three design alternatives for the laryngeal bioreactor. The highest scores per category are highlighted in a darker color. The cage design garnered the most points.**

	Weight	Mesh		Cage		Operating Table	
Precision of turning	5	2	2	3	3	4	4
Safety	5	4	4	4	4	2	2
Ease of use	10	3	6	4	8	3	6
Manufacturability	10	4	8	3	6	4	8
Cost	10	3	6	3	6	2	4
Compatibility with various environments	10	3	6	3	6	3	6
Durability	15	2	6	4	12	3	9
Support	15	2	6	4	12	5	15
Access to media	20	3	12	4	16	1	4
<b>Sum</b>	100	56		73		58	

The three design alternatives were evaluated on nine different criteria. Precision of turning and safety were given low weights since fluids will be perfused through the entire vasculature of the larynx and because there are no dangerous components in the designs. The operating table design scored highest in precision because the larynx will be rigidly pinned to the surface, whereas in the mesh design the larynx would have the ability to slide slightly. The operating table makes use of pins to attach the larynx to the device, which increases the chance for accidental injury.

Ease of use for the client, ability for the team to manufacture the device, cost, and compatibility with different lab environments were all weighted the next lowest following safety and turning precision. The cage mechanism was deemed easiest for the client to use, but most difficult for the team to manufacture. The cage allows the user easy access to the larynx and tubes due to the removable cage components and the fewer attachment points; however, the mesh and table could potentially be bought, and the cage will most likely need to be custom fabricated. The cost of the table design was predicted to be the highest, as it would require more support and possibly a stronger motor for the entire table to be turned. In regards to operating environment, all three designs must function in a standard lab environment, a refrigerator, and an incubator as per the product design specifications. For this reason, all three designs scored equally in this category.

The highest weighted criteria were durability of the device, support of the larynx during the process, and the ability for the larynx to access media (which was weighted slightly higher). The device is used for up to three weeks at a time, and therefore must be durable enough to not break during that period. Furthermore, the geometry of the larynx changes throughout the three weeks, especially as it decellularizes. It is important that the design supports the larynx during this time. Most importantly, the larynx must have

access to media and surrounding fluids in order for the decellularization and recellularization to be successful.

The mesh design received the lowest score in both durability and support categories. The mesh will not be as durable as the other designs since it would be made of a flexible polymer and have the potential to tear. In addition, it would not provide any rigid support and could possibly allow the larynx to sag. The cage was determined to be the most durable, as pins would not be inserted into it like in the table design and because the motor would have less strain on it. The table was considered to be the most supportive because it reinforces the entire length of the larynx. The design that allowed for the greatest access to media was the cage design. The operating table design would pin the entire dorsal side of the larynx to the table and would not allow media to effectively reach this area. In a similar fashion, the mesh would have to be relatively tight and would thus leave small areas where media could not diffuse into the larynx. For this reason, the cage was given the highest score for access to media.

### **Final Design**

Compiling the results of the design matrix analysis reveals that the cage design is the best choice to adequately meet the needs of the client. This design received the most points overall, and high scores in the three highest weighted categories. The lowest score it received was in manufacturability, as it will most likely need to be fabricated as opposed to purchased and assembled. However, this had a minimal effect on its score and the cage design is ultimately the design the team will use.

To reiterate, the cage design has a semi-circular shape (when the top bars are removed) that allows the user easy access to the tubes and larynx. The tubes have a small chance of decannulating during rotation, so it is important that the client can remedy the situation easily. Rotation of the cage 90 degrees in either direction exposes all surfaces to the exterior media, while continuing to support the larynx as its geometry changes over time. The plastic sides of the cage will be durable enough to withstand the weight of the larynx, while light enough to refrain from stressing the motor and cage attachment.

### **Budget**

The most expensive components of this device are the pumps used to circulate fluid through the inner lumen and pump into the vasculature. These pumps have already been purchased by the client for last year's design team, and can be reused for this design. Other expenses include sheets and rods of polycarbonate plastic, which range from \$10 to \$30 dollars, depending upon thickness and sizes needed. An Arduino Uno microcontroller will be used to control the turning of the stepper motor and cage. This microcontroller costs approximately \$30. The price of the stepper motors with the potential for use in our application ranges from \$20-50.



## **Ethics**

As with any bioengineered tissue, there are several facets of ethical concerns associated with this project. First, xenographic tissue will be used in experimentation, and animal rights must be respected (according to the national guides for laboratory animal welfare) for bioreactor use. This means that any tissues used should not be wasted. Additionally, the bioreactor is intended to be used with allograft tissue that will be decellularized and reseeded with the patient's own adult stem cells. The donor of tissue that will be used must have their wishes respected and their privacy maintained if desired. Additionally, the use of adult stem cells, while less ethically objectionable, than the use of embryonic stem cells, still leads to ethical concerns associated with the profit of a company from someone else's tissues, as well as the patients ownership of their own tissues (including patents) (21). In any case, the wishes and privacy of the patient should be respected in future applications of this product in order to avoid these issues.

Specifically for the case of the bioreactor itself, there is another set of ethical concerns. Any larynges could cause a great deal of harm if they are not properly decellularized and recellularized prior to implantation. If components of the bioreactor are not properly sterilized before use, as well as if the larynx is not grown in a sterile environment, unwanted pathogens could be introduced into the tissue, leading to a heightened immune reaction in the recipient of the tissue. Additionally, researchers must ensure that there is no longer any foreign media or non-laryngeal tissue in the regrown organ prior to implantation, as this could lead to major complications for the recipient.

## **Future Work**

Moving forward, more research must be done on the materials that will comprise the device, such as the plastic for the outer encasement and motor housing, as well as which motor will best meet the team's needs. Additionally, more work needs to be done on the rotation mechanism. For instance, the method of attaching the cage to the motor still needs to be designed in Solidworks. Once the design is complete and materials have been ordered, the prototype will need to be constructed and tested with larynges provided by the client.

There are various facets of testing that will need to be completed for this device. First, the device will be tested to see if the cage design adequately rotates the larynx so the entire surface comes into contact with media. This will be done with a larynx analog and colored dye to show that the entire surface is covered. The analog will be attached to the cage, and the stepper motor programmed to turn 90° clockwise, then 180° counter-clockwise. Additionally, the tubes that perfuse liquid through the inner lumen and vasculature will also need to be tested with the rotation mechanism to ensure that they do not fall out when twisted. This will be done by cannulating the larynx and rotating the cage in small steps until the tubes detach. This will provide a maximum degree of rotation that can be used by the client. This series of tests will need to be completed at least three times to attain good statistical data that adequately represents the performance of the prototype.

Fluid mechanics testing should also be conducted on the prototype to properly characterize the flow rates of the device as well as the potential shear rates on the tissues during experimentation. This will be done in at least two different tests. First, the team will test the filling and draining rates of the device, both of the inner lumen and the outer chambers, by attaching a larynx analogue to the device and timing how quickly the inner lumen and the outer chamber can be filled at various pump speeds. From this test the team can properly characterize how pump speeds relate to filling rates and adjust the automation of the device accordingly. Second, the team can record how long it takes approximately 5 mL of fluid to completely circulate from the reservoir, through the inner lumen and back to the reservoir at different pumping speeds. This test will allow the team to derive a mathematical relationship between the pump speed and the flow rates through the device, as well as relating this, through basic fluid dynamics equations, to the shear stresses that the tissues are subjected to during this process. Again, this series of tests should be conducted at least three times to attain good statistical data that adequately represents the performance of the prototype. However, due to the fact that each of these tests are rather quick and easy to run, these should be run at least five times each.

Another facet of testing that will need to be completed is analyzing the effectiveness of the prototype. More specifically, the team will need to test the device to ensure it can both decellularize the larynx to form a scaffold, and recellularize with healthy cells. Characterization of the decellularized larynx will be done using a combination of histological staining, live/dead assays. These tests can both qualitatively and quantitatively show the effectiveness of the prototype in decellularizing a larynx, as they will show where and how many cells in the tissue are dead. For the recellularization portion, the team intends to use an RNA microarray to assay for early indicators of cell differentiation that show that different cells are becoming cartilage, muscles, and ligaments, in locations needed by the organ. Each of these tests should be conducted at least three times, however, high media costs may prevent testing to this extent. Therefore, the team will investigate using a cellular larynx analogue (such as cells incorporated into a scaffold) that does not need media that is nearly as expensive to complete testing. Results from all of the tests discussed will allow iterative design on the prototype.

The timeline and thus the time management planning for the work discussed in this section can be seen in appendix B below. In the upcoming weeks, the team intends to research and order materials, as well as assemble the prototype. This will be followed by the testing as discussed above.

### **Acknowledgements**

The team would like to thank our advisor, Dr. Tracy Puccinelli, for her assistance with the project. Additionally, the team extends our thanks to Dr. Nathan Welham and Dr. Yutaka Toya for proposing and facilitating the project. Finally, we would like to thank the previous BME design team, particularly Armand Grabowski, for his input into the project.

## References

1. "Organ Donation: The Need Is Real." *Organdonor.gov*. US Department of Health and Human Services, n.d. Web. 06 Oct. 2013. <<http://www.organdonor.gov/about/data.html>>.
2. Hou, Nan, Pengcheng Cui, Jiasheng Lou, Ruina Ma, and Li Zhu. "Tissue-engineered Larynx Using Perfusion-decellularized Technique and Mesenchymal Stem Cells in a Rabbit Model." *Acta Oto-Laryngologica* 131 (2011): 645-52.
3. Song, John, and Ed Zimmey. "Is It Hard to Live With a Stoma After Laryngeal Cancer?" *EverydayHealth.com*. Everyday Health Media LLC, 23 June 2008. Web. 06 Oct. 2013.
4. Strome, Marshall, Jeannine Stein, Ramon Esclamado, Douglas Hicks, Robert R. Lorenz, William Braun, Randall Yetman, Isaac Eliachar, and James Mayes. "Laryngeal Transplantation and 40-Month Follow-up." *New England Journal of Medicine* 344.22 (2001): 1676-679.
5. Varney, Sarah. "Larynx Transplant On Calif. Woman Successful." *NPR*. N.p., 20 Jan. 2011.
6. Coghlan, Andy. "First Synthetic Larynx Part Transplanted." *NewScientist*. Reed Business Information Ltd, 27 June 2012. Web. 6 Oct. 2013.
7. Vashishta, Rishi. "Larynx Anatomy ." *Medscape*. WebMD, 21 June 2013. Web. 10 Sept. 2013. ( <http://emedicine.medscape.com/article/1949369-overview> )
8. Dance, Milton. "Anatomy and Physiology." *Greater Baltimore Medical Center*. N.p., 2010. Web. 8 Oct. 2013. <[http://www.gbmc.org/home\\_voicecenter.cfm?id=1552](http://www.gbmc.org/home_voicecenter.cfm?id=1552)>.
9. "Cancer of the Larynx." *National Cancer Institute*, 21 Jan. 2011. Web. 03 Oct. 2013. <<http://www.cancer.gov/cancertopics/wyntk/larynx/page2>>.
10. Vashishta, Rishi. "Vocal Cord and Voice Box Anatomy." *Medscape*. WebMD, 21 June 2013. Web. 10 Sept. 2013. ( <http://emedicine.medscape.com/article/1949369-overview> )
11. Skandalakis, John E. "AccessSurgery." *The McGraw-Hill Companies*. Silverchair Information Systems, 2006. Web. 08 Oct. 2013. <[http://web.uniplovdiv.bg/stu1104541018/docs/res/skandalakis' surgical anatomy - 2004/Chapter 05\\_Larynx.htm](http://web.uniplovdiv.bg/stu1104541018/docs/res/skandalakis%27%20surgical%20anatomy%20-%202004/Chapter%2005_Larynx.htm)>.
12. "Stem Cell Basics." *National Institute of Health*. U.S. Department of Health and Human Services, 28 Apr. 2013. Web. 06 Oct. 2013. <<http://stemcells.nih.gov/info/basics/Pages/Default.aspx>>.

13. Badylak, Stephen F., Doris Taylor, and Korkut Uygun. "Whole Organ Tissue Engineering: Decellularization and Recellularization of Three-Dimensional Matrix Scaffolds." *Annual Review of Biomedical Engineering* 13.1 (2010): 27-53.
14. Kardaleva, Anna. "Medical Breakthroughs: A Slideshow of Recent Medical Breakthroughs from Top Research Labs around the Globe." *Design Mind*. Frog Design, n.d. Web. 6 Oct. 2013. <<http://designmind.frogdesign.com/articles/health/medical-breakthroughs.html>>.
15. Kim, M., E. Hunter, and I. Titze. "Comparison of Human, Canine, and Ovine Laryngeal Dimensions." *Annals of Otolaryngology, Rhinology & Laryngology* 113.1 (2004): 60-68.
16. Ott, Herald, Thomas Matthiesen, Saik-Kia Goh, Lauren Black, Stefan Kren, Theoden Netoff, and Doris Taylor. "Perfusion-decellularized Matrix: Using Nature's Platform to Engineer a Bioartificial Heart." *Nature Medicine* 14.2 (2009): 213-21.
17. Petersen, Thomas H., Elizabeth A. Calle, Maegan B. Colehour, and Laura A. Niklason. "Bioreactor for the Long-Term Culture of Lung Tissue." *Cell Transplantation* 20 (2011): 1117-126
18. Gilbert, T., T. Sellaro, and S. Badylak. "Decellularization of Tissues and Organs." *Biomaterials* 27.19 (2006): 3675-683.
19. Titze, I., R. Hitchcock, K. Broadhead, K. Webb, W. Li, S. Gray, and P. Tresco. "Design and Validation of a Bioreactor for Engineering Vocal Fold Tissues under Combined Tensile and Vibrational Stresses." *Journal of Biomechanics* 37.10 (2004): 1521-529.
20. Asnaghi, M. Adelaide, Philipp Jungebluth, Manuela T. Raimondi, Sally C. Dickinson, Louisa E.N. Rees, Tetsuhiko Go, Tristan A. Cogan, Amanda Dodson, Pier Paolo Parnigotto, and Anthony P. Hollander. "A Double-chamber Rotating Bioreactor for the Development of Tissue-engineered Hollow Organs: From Concept to Clinical Trial." *Biomaterials* 30.29 (2009): 5260-269.
21. Brey, P. (2009). 'Biomedical Engineering Ethics.' Eds. Berg-Olsen, J., Pedersen, S., Hendricks, V. (eds.), *A Companion to Philosophy of Technology*. Blackwell.

## Appendix A: Product Design Specifications

### **Bioreactor for Laryngeal Tissue Engineering**

*Date:* October 9, 2013

*Team:* Dan Thompson, Rebecca Stoebe, Kyle Anderson, Peter Guerin

*Advisor:* Dr. Tracy Puccinelli

*Client:* Dr. Nathan Welham

**Problem Statement:** The larynx has three major functions physiologically. It separates the windpipe from the esophagus, is important in swallowing, and has a major function in sound production. When a problem occurs in the larynx, all three functions can be disrupted. Our purpose is to design a laryngeal bioreactor that can decellularize a larynx to make a scaffold and recellularize it with patient-specific cells. A previous team designed a device that adequately decellularized the tissue, but recellularization had not been thoroughly tested. The client would like an iteration of the design that keeps the larynx horizontal during the experiment and allows easy access to the catheters supplying fluids through the vasculature. This semester, the team should focus on building a design that allows cells to be exposed to both air and media during cellular growth while allowing researchers to view the experiment taking place. Additionally, the team should seek to incorporate and build upon the automation system that the previous team began constructing.

**Function:** The device will serve to perfuse and support laryngeal tissue to aid in the decellularization of existing cells and recellularization with patient-specific cells.

#### **Client requirements:**

- The bioreactor must be able to decellularize and recellularize a human, pig, or dog larynx
- The bioreactor must be able to function in a lab environment, in a refrigerator, and in an incubator
- The bioreactor must be able to function continuously for up to three weeks in time
- The bioreactor must be sterile and capable of interfacing with the previous group's pumps

#### **Design requirements:**

##### **1. Physical and Operational Characteristics**

a. *Performance requirements:* The bioreactor needs to be able to create an acellular scaffold by decellularizing a larynx. After decellularization, the bioreactor needs to be capable of housing the larynx and repopulating the scaffold with new cells. Tubes and inlets connecting to various parts of the larynx must not be torn out or slip out during use. Additionally, the bioreactor should be able to be programmed to be filled and drained automatically. Finally, the bioreactor should not be airtight.

b. *Safety*: The device will be used in conjunction with chemicals; therefore chemical exposure must be prevented. The device needs to be sterile to prevent future contamination/inflammatory responses, or functional loss after implantation and therefore needs to be autoclavable.

c. *Accuracy and Reliability*: The device must be able to provide and/or facilitate consistent decellularization and recellularization over multiple larynges. The bioreactor needs to function for up to three weeks in time without functional loss. The bioreactor should be able to be programmed to rotate the larynx at a rate between 1 rotation per 10 minutes and 1 rotation per hour. Any partial rotations should be accurate within 10° of the desired orientation. As the scaffold becomes decellularized, it becomes more flaccid, and the bioreactor must be able to still hold the larynx in place even with these changes.

d. *Life in Service*: Our client intends to use the device for several months over the course of the current research study. The device must function accurately and reliably over that time in segments of continual use for several days (for decellularization) to three weeks (for recellularization). The bioreactor must be reusable.

e. *Shelf Life*: The device should maintain its functionality for as long as possible so the client can use it in multiple similar studies

f. *Operating Environment*: The device must be able to function in a refrigerator environment, a standard lab bench environment, and an incubator environment for up to 3 weeks at a time.

g. *Ergonomics*: The device must not place unnecessary strain on the user. It needs to be reasonably movable and provide easy access to the tissue specimen.

h. *Size*: Overall size of the device must be limited to prevent crowding on the bench top, but large enough to house a human or large animal model larynx (which can be up to 6 cm in length without the trachea). Additionally, the bioreactor should be small in order to conserve media while being large enough to easily allow the installation of a larynx.

i. *Materials*: All materials used in the device must be biocompatible with fresh tissue and support cell viability. None of the materials should degrade in the media used during decellularization or recellularization. All materials must be autoclavable.

j. *Aesthetics, Appearance, and Finish*: Although the client expressed no preferences as to aesthetic quality, the design should appear finished and professional.

## **2. Production Characteristics**

a. *Quantity*: One prototype serving as the second iteration of the design, with the assumption of future modifications.

b. *Target Product Cost*: \$1-3,000

### **3. Miscellaneous**

a. *Standards and Specifications*: None aware of at this time

b. *Customer*: Dr. Nathan Welham and his fellow researchers

c. *Patient-related concerns*: None

d. *Competition*: None for the whole larynx. However, bioreactors have been made for whole trachea as well as vocal folds.

## Appendix B: Timeline

Task	September				October				November					December	
	6	13	20	27	4	11	18	25	1	8	15	22	29	6	13
<b>Research</b>															
Background/Motivation															
Materials/Design															
Cost Estimation															
Testing/Methods															
<b>Development</b>															
Ordering Materials															
Manufacturing															
Testing															
<b>Deliverables</b>															
Progress Report															
PDS Report					<b>Due</b>										
Midterm Report					<b>Due</b>										
Midterm Presentation					<b>Due</b>										
Final Report															<b>Due</b>
Final Presentation															<b>Due</b>
<b>Meetings</b>															
Client															
Team															