

Metered Dose Inhaler Drug Delivery System for Rats

Final Report - Fall 2014

BME 200/300

University of Wisconsin - Madison

Department of Biomedical Engineering

Nick DiFranco (Team Leader)
Claire Hintz (BSAC)
Yitong He (BWIG)
Katie Schwarz (Communicator)
Jason Wan (BPAG)

Advisor: Dr. Jeremy Rogers

Clients: Dr. Mihaela Teodorescu and Dr. Oleg Broytman

Abstract

Our clients, Dr. Mihaela Teodorescu and Dr. Oleg Broytman from University of Wisconsin - Madison School of Medicine and Public Health, asked our team to create a system that will modify a traditional metered dose inhaler (MDI) for use by rats in a laboratory research setting. The operation of the MDI is automatic, and the medicine will be dispensed to the rats in a way that simulates human operation and usage of the device. The modified mouthpiece nozzle and automation circuitry are completed as one system. The system is activated by a force sensitive resistor and consists of an arduino microprocessor, two servo motors, and a piece of plastic to press down the inhaler. The medicine is dispensed through the 3D printed nozzle.

Table of Contents

Problem Statement	3
1.0 Introduction	3
1.1 Background	3
1.2 Motivation	5
2.0 Design Specifications	5
2.1 Client Requirements	5
3.0 Design Alternatives	6
3.1 Nozzle	6
3.2 Automation System	7
4.0 Design Matrices	8
5.0 Final Design	10
5.1 Nozzle	10
5.2 Automation system	11
5.2.1 Mechanism	11
5.2.2 Circuit	12
6.0 Testing and Analysis	12
7.0 Future Work	14
7.1 Testing	14
7.2 Nozzle Fabrication	14
7.3 Other Modifications	14
7.4 Medical Applications	14
8.0 Conclusion	15
9.0 Acknowledgements	15
10.0 References	15
11.0 Appendix	16
11.1 Costs	16
11.2 Timeline	17
11.3 Product Design Specifications (PDS)	18

Problem Statement

Research is being conducted on the side effects of corticosteroid medications, in particular the effects on the musculature of the tongue and upper airway because atrophy of those muscles can lead to sleep apnea. The goals of this project are to modify the mouthpiece of a metered dose inhaler (MDI) to allow for use by rats in a laboratory setting and integrate an automated system to dispense the medicine. The mouthpiece must be fitted with a custom nozzle sized appropriately for rat usage, as well as account for the fact that the rats will probably not voluntarily put their mouths around the nozzle. A way to train the rats to voluntarily and correctly use the mouthpiece should also be developed.

1.0 Introduction

1.1 Background

Metered dose inhalers (MDI) are special devices that deliver a set amount of medicine through an aerosol mechanism (PROAIR). These inhalers are widely used by many throughout the world. The research efforts of Dr. Teodorescu's laboratory are currently directed towards discovering the side effects of corticosteroid medications administered through an MDI. The research is specifically observing the effects the medicine has on the musculature of the tongue and upper airway. It is a possibility that corticosteroids may lead to the weakening of the muscles of the upper airway.

The weakening of such muscles may cause many medical issues, but perhaps the most apparent is sleep apnea. Sleep apnea is linked to two possible causes. The first is "central," where the brain does not send appropriate signals to the muscles of that control breathing. The second is "obstructive," in which muscles of the airway, specifically those surrounding the throat, are not operating correctly and are in a relaxed state (Mayo Clinic).

The musculature and physiology of the upper airway are shown in Figure 1. Due to exposure of the corticosteroid used through MDIs, these muscles may weaken and collapse, ultimately unable to properly function. The deterioration of these muscles can become responsible for other medical issues such as sleep apnea (Furest).

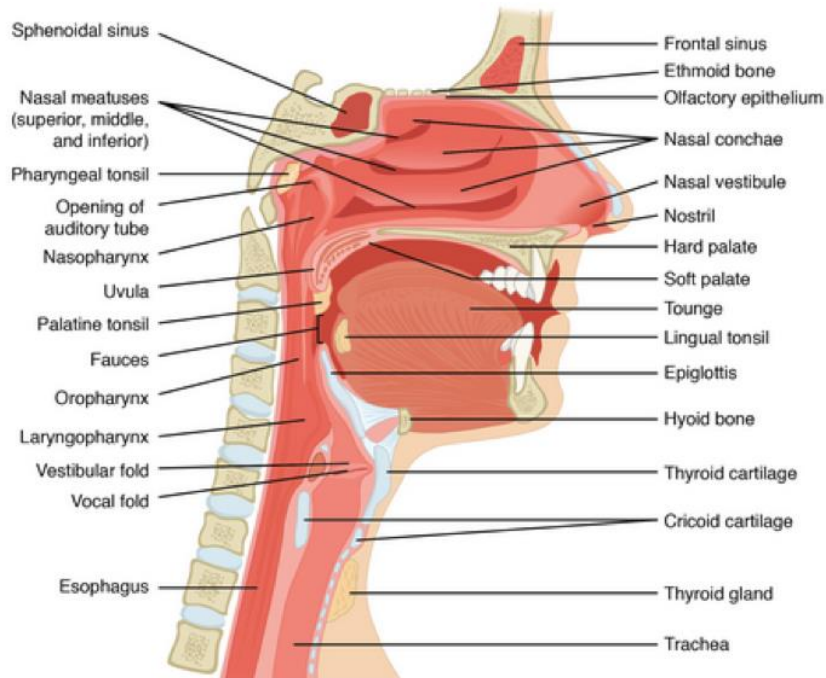

Figure 1. Human Upper Airway (Organs and Structures)

Corticosteroid medications are quite frequently delivered through the mechanism of a metered dose inhaler. With this specific vehicle for medicine delivery in mind, Dr. Teodorescu is hoping to understand if there is a correlation between the corticosteroids delivered through an MDI and the deterioration of the muscles of the tongue and upper airway.

In Dr. Teodorescu's laboratory, rats are the subjects for testing. It is important to recognize a few discerning differences between humans and rats. Rats naturally breathe through their noses, whereas humans breathe through both the mouth and nose. Additionally, rats primarily lick and gnaw to consume food. These differences may seem minor, however they will greatly influence both how training will work and how our design will be created.

In order to mimic the behavior of how a human would use an MDI, it is important to create a system in which the rats will not only voluntarily use the nozzle but also use it in a correct fashion, allowing the medicine to be dispensed in their mouths. This is to ensure that the results of testing are accurate and reliable.

Currently on the market, there are modified inhalers for small animals that involve a mask that is placed over the animal's face (5). While this design is useful for administering inhaled medicine to the animals, it does not accurately simulate how a human uses an inhaler, where the majority of the medicine is deposited on the tongue and in the upper airway. Other research has involved administering inhaled corticosteroids to rats. One method (6) used by researchers involved modifying an infant MDI spacer chamber. The mask was removed and the spacer chamber was placed directly over the rat's nose and mouth. In another scientist's research, (7) a homemade chamber was made by cutting the bottom off of a 2-liter soda bottle, and the rat was trained with a treat to go to the narrow end, where the puff was delivered.

1.2 Motivation

Dr. Teodorescu's research is aimed to learn and discover if there is a correlation between MDI delivery of corticosteroid medications and weakening of the musculature of the tongue and upper airway. In order to reach reliable results, it is important to develop a mechanism where rats can mimic humans' usage of the drug delivery system. Instead of forcing medicine to be dispensed in a rat's mouth, they must operate the MDI voluntarily.

For this ideal situation to occur, there must be a specific technique to dispense the corticosteroid medication through an MDI into the rats' mouths. With medicine dispensed directly into the targeted area, the results of such a practice should be more accurate and reliable, as this further mimics the delivery of medicine for a human.

It is clear that a rat's mouth is not as large as a human's. In order to mimic the delivery of the medicine to the mouth, a scaled mouthpiece must be implemented. This would convert the current size of the mouthpiece used for humans into a reasonably sized opening for rats, while not affecting the volume of medicine dispensed.

In addition, dispensing medicine by hand for each dose can be inefficient and requires a great amount of time. With this in mind, an automated dispensing system is not only ideal but also desired.

With this specialized, automated MDI for rats, Dr. Teodorescu can accurately and reliably analyze the possible correlation between MDI delivery of corticosteroid medications and weakening of the musculature of the tongue and upper airway.

2.0 Design Specifications

2.1 Client Requirements

In terms of the modified nozzle, the clients specified that it must be sized appropriately to fit naturally in a rat's mouth, and operate as a detachable piece that fits tightly on the existing inhaler mouthpiece. The specifications laid out concerning the type of material to be used to fabricate it were that it should be nontoxic and safe for rats to use, durable enough to withstand repeated rat bites over time, and able to safely undergo sterilization. Further, the material must be one to which the medicine does not adhere to ensure the rats receive the proper dose.

For the automation system, the clients indicated that it should not only automatically administer a puff of medication when the rat's mouth is on the nozzle, but also reset itself afterwards without any researcher intervention.

3.0 Design Alternatives

3.1 Nozzle

For the design of the nozzle piece that will be situated on the existing mouthpiece of the MDI, a few key features are necessary in order for it to function as it needed to. One of the requirements for the design includes that the nozzle fits tightly on the mouthpiece to prevent a leak of the medication, as well as to ensure that the nozzle stays on throughout the experiment. Another component necessary to the design is that the nozzle scales down on the outer end to a size that can comfortably fit in the rats' mouths. One more key aspect of the nozzle design is that the hole at the end of the nozzle should be as closely lined up to the hole in the mouthpiece that dispenses the puff of medication as possible. This will help deliver the medication in the most consistent puff possible by eliminating potential space inside the nozzle where the medication could get partially blocked.

These constraints and specifications led to only one feasible option for the design of the shape of the nozzle, pictured below in Figure 2.

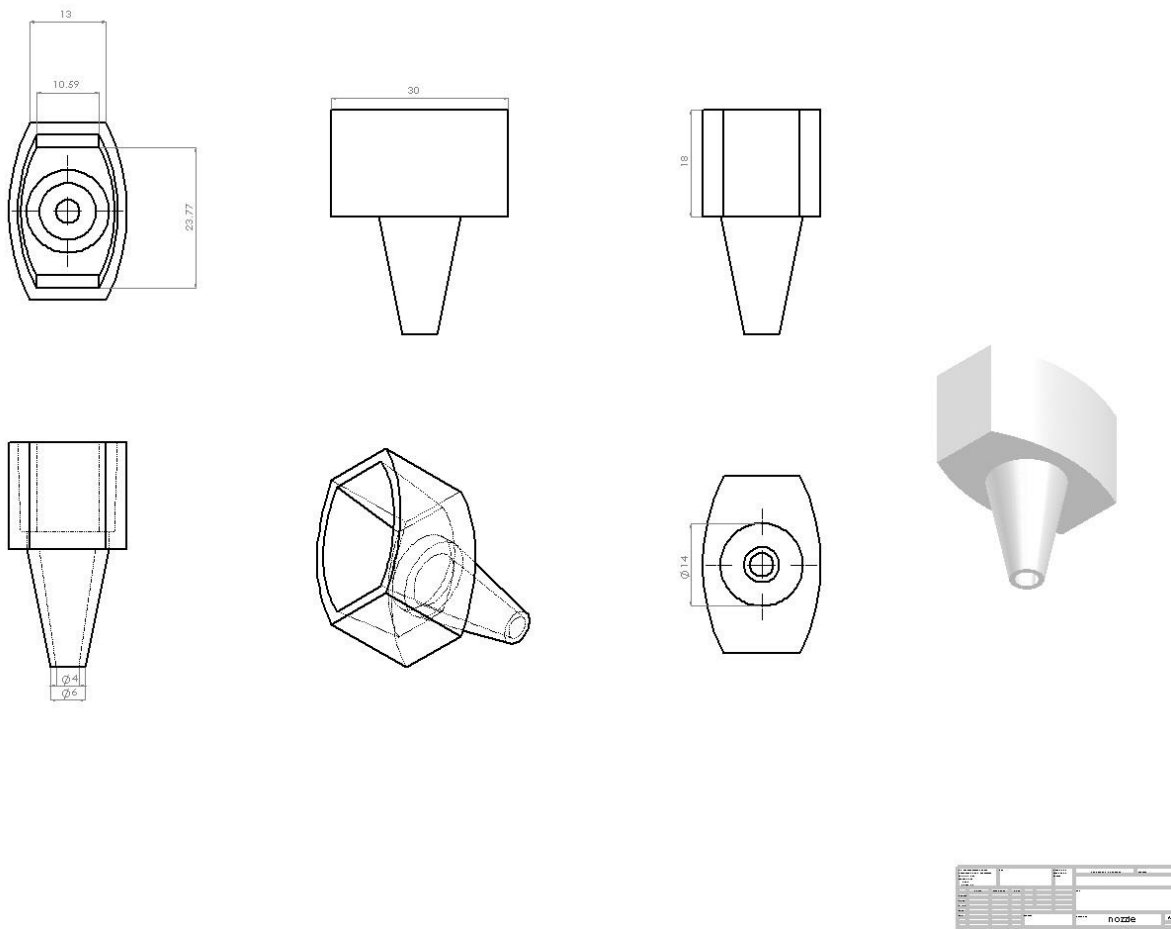

Figure 2. Nozzle Design with Dimensions

Thus, the only variability in nozzle design alternatives was due to the material to be used to fabricate it. The two options considered were a hard plastic material such as ABS that would be relatively durable, and a softer plastic material such as rubber or silicone, that would be flexible yet sturdy enough to withstand rat bites.

3.2 Automation System

For the automation system, two possibilities were considered. One option was to create a mechanical system that is activated by the rat biting on the hard plastic nozzle. The second option could incorporate either the hard or the soft nozzle that utilizes a force-sensitive resistor (FSR) and a servo motor run by an Arduino system.

The first system (Design 1) uses the force from the rat's bite and transfers the force up to the canister to release the puff of medication through the nozzle. This is accomplished by creating a solid piece that is situated on the MDI with two plates connected by braces. The first plate is the "bite plate", which is situated on top of the nozzle above a divot, which will allow it to move down when bitten. The braces that run up the side are connected to this plate and another circular plate that is on top of the canister. The goal with this design is that the force applied by the rat bite at the lower plate will shift the entire system downward, with the force transferred to the upper plate pressing the canister down enough to release the medication.

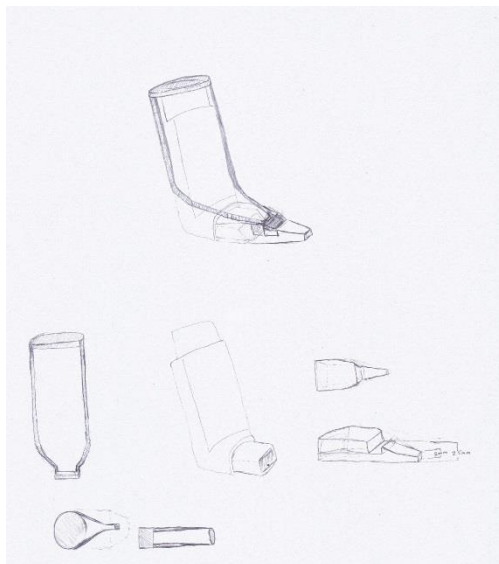

Figure 3. Bite-Activated Automation System (Design 1)

The second system (Designs 2 and 3) is initiated when the rat places its mouth over the nozzle. Since the nose of the rat sticks out further than the mouth, it will push against a small metal plate positioned toward the end of the nozzle. The plate is affixed by a ring to a metal or wire rod, which it will slide along when pushed, until it makes contact with the FSR. The input from the FSR will be sent through an Arduino microprocessor to a servo motor, whose arms will be connected to rods and a weight positioned over the canister of the MDI. When the servo motor receives the input, the arms will be moved down, and this will bring down the rods, pressing the weight onto the canister and dispensing the medicine for a controlled amount of time.

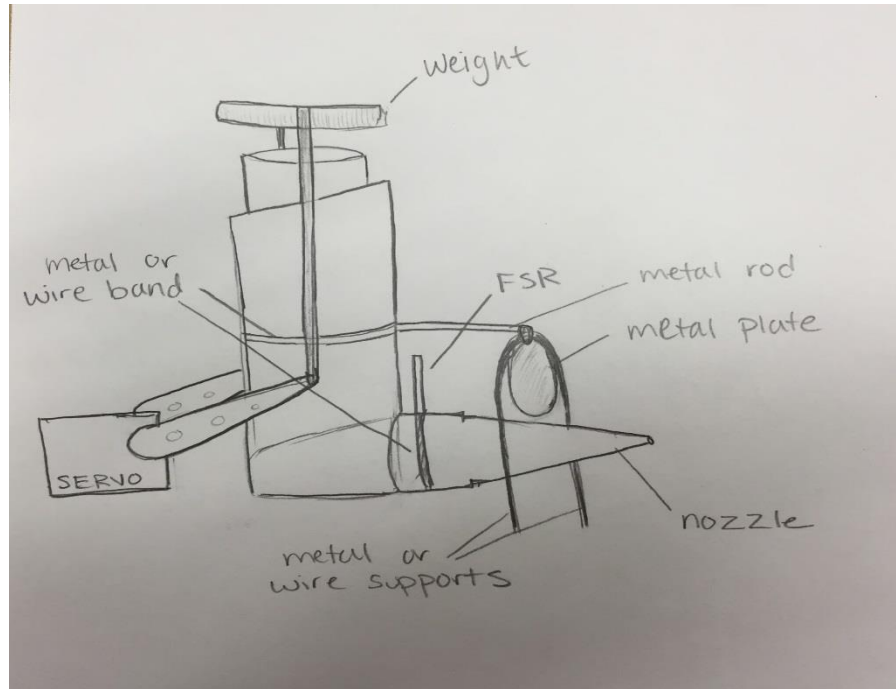

Figure 4. Force-Sensitive Resistor Automation System (Designs 2 and 3)

4.0 Design Matrices

To select a final design from these three potential options, a design matrix was constructed to easily identify which of the options most satisfactorily met the product design specifications. The design matrix may be seen below in Table 1.

Design	Hard Nozzle with Mechanical System		Hard Nozzle with Force Sensor		Soft Nozzle with Force Sensor	
Criteria (weight)						
Accuracy of Simulation (25)	2/5	10	4/5	20	4/5	20
Ease of Fabrication (25)	4/5	20	3/5	15	3/5	15
Durability (20)	2/5	8	4/5	16	3/5	12
Ease of Use (15)	4/5	12	4/5	12	4/5	12
Safety (10)	5/5	10	5/5	10	5/5	10
Cost (5)	5/5	5	3/5	3	4/5	4
Total (100)		65		76		73

Table 1. Design Matrix of Three Design Alternatives

While selecting criteria and assigning their relative weights, accuracy of the simulation was regarded as one of the most crucial considerations. Seeing as our client will be using the product to study the potential adverse effects of inhaled corticosteroids on the upper airway, accuracy is

of the utmost importance; the simulation must mimic the drug delivery of a standard MDI to a human subject as much as possible and accurately deposit the medication in the oral cavity to ensure useful and applicable research results. Both Design 2 and Design 3 were ranked higher with regard to this criterion, as the programmed system was expected to deliver the medication more precisely than the mechanically automated Design 1, which could fail to administer the drug if, for example, the rats fail to bite on the nozzle with sufficient force.

Ease of fabrication was also considered to be very important and assigned the same weight as accuracy due to the fact that several replicates will eventually have to be manufactured for training purposes and for rats of varying ages and sizes. Also, the project duration was only one semester; therefore, the team wanted to be able to accomplish this project in the allotted amount of time. Design 1 was regarded as the easiest to fabricate compared to the Arduino system programming and FSR setup that must be done in Designs 2 and 3.

Durability was considered to be the category of the next most importance. Per client request, the design should ideally last indefinitely, so it was important to select a design that is durable enough to meet these expectations. Design 1 received a lower durability score because the rats must bite down forcefully on the nozzle for the drug to be administered, which could lead to deterioration. However, since the rats are to insert the nozzle of Designs 2 and 3 into their mouths, it is reasonable to assume they will gnaw on it, too, especially if they are trained to use the MDI with food. Seeing as Design 2's hard plastic nozzle would withstand rat bites more effectively than the soft nozzle of Design 3, Design 2 was ranked the highest in terms of durability.

Ease of use for humans was assigned the next highest weight because the product should be straightforward enough that researchers in the lab can be trained to use it without error. The fact that each design is automated contributes to their ease of use; however, none of the designs received a perfect score in this category because they all require some set up by the researchers before they are ready to use in the lab.

Next, safety was considered. Potential safety hazards had been taken into consideration while prototyping the designs to ensure a high degree of safety in each design option. For example, in Designs 2 and 3, the rat's nose pushes a plate into the FSR rather than directly touching it with its nose to increase the distance between the rat and the sensor, eliminating the risk of gnawing on the system's wiring. By taking such considerations into account while prototyping, each design was ranked very highly in terms of safety as a result.

Finally, the criterion of cost was assigned the least weight in the matrix, as the allotted \$1,000 budget seemed certainly sufficient to produce a high quality product. Designs 2 and 3 were ranked lower than Design 1 in terms of cost due to their utilization of FSRs, motors, and Arduino systems. Design 2 in particular was found to be the most expensive option when the costs of nozzle materials were considered.

After putting each design option through the matrix, Design 2 was found to be the winning design that embodied the product specifications most effectively.

5.0 Final Design

The final design of the automated drug dispensing system for rats consists a modified-sized nozzle, which was sketched on the SolidWorks and manufactured on the 3D printer, along with an automated dispensing system. The dispensing system incorporates a system of a force-sensitive resistor (FSR) and two servo motors, controlled by an Arduino microprocessor. The FSR is positioned over the nozzle, so that when the rat places its mouth over the nozzle, its nose presses against the FSR. The Arduino is programmed to accept any value above 150 from the FSR as an input that triggers a rotation of the servo motors for two seconds. A fishing wire is wound around the arm of each servo motor and threaded through two holes in a circular plastic piece that is placed on top of the inhaler. When the motors turn forward, the wire is wound around the arms, and the plastic piece is pulled down, depressing the inhaler. The Arduino is then programmed to spin the motors backward, which releases the tension in the wire, and resets the system.

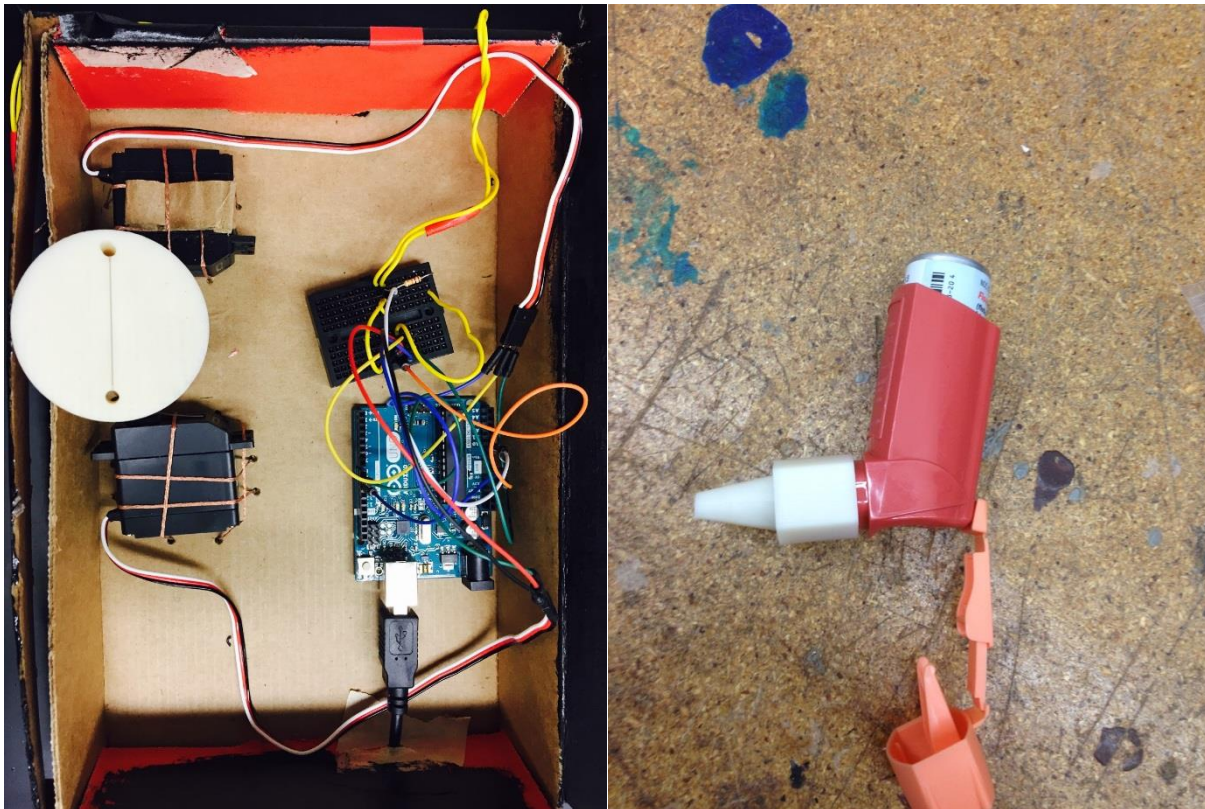

Figure 5. Final Design of the Automated System and Nozzle

5.1 Nozzle

The final design for the nozzle ended up being 3D-printed rather than fabricated in the machine shop, since the machined nozzle ended up breaking during the fabrication process, and the 3D-printed one ended up fitting better to the shape of the inhaler mouthpiece. The dimensions for the nozzle took into account several design constraints. One constraint reflected in the dimensions was that the rat needed to be able to fit its mouth over the end, and with an outer diameter of 6mm at its end, this design qualifies according to the measurements made. Also, the design of

the nozzle must allow the medication to flow freely through it and maximize the amount of medication released, and the uniform narrowing from base to end achieves this by allowing the medication to be dispensed without building up inside the nozzle. Finally, the nozzle needed to fit snugly onto the inhaler mouthpiece, which it does since the exact measurements from the sample MDI were used for the base dimensions. Figure 5 shows an image of the SolidWorks used for 3D-printing the nozzle.

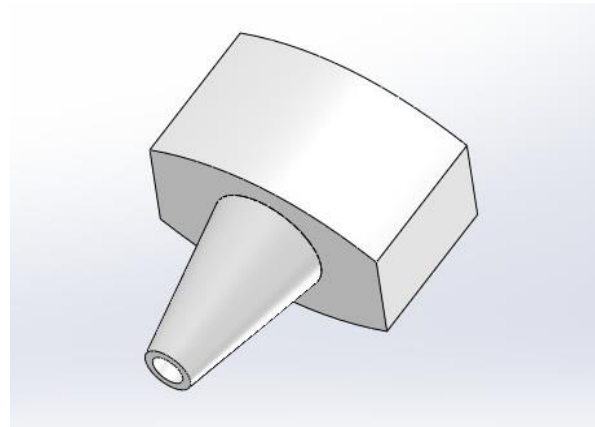

Figure 6. Nozzle Design on SolidWorks

5.2 Automation System

5.2.1 Mechanism

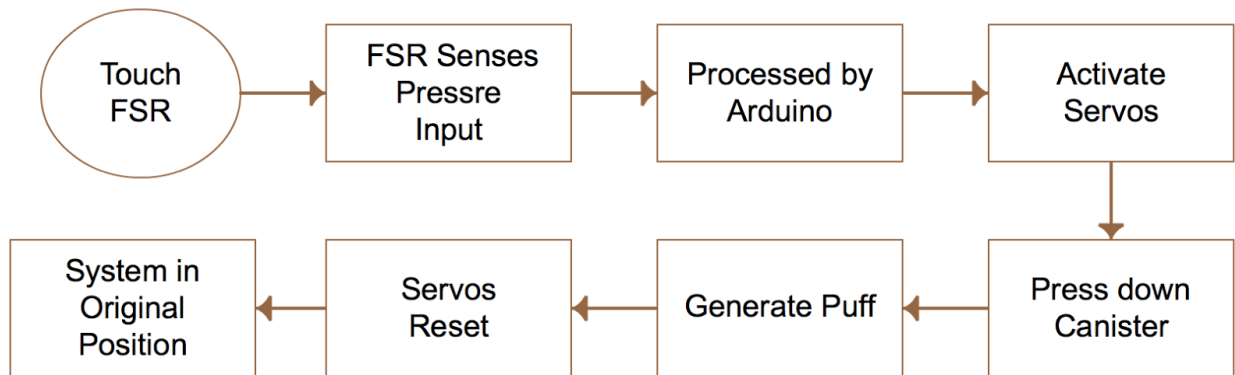

Figure 7. Block Diagram of the Automated System

The mechanism of the automated drug dispensing system is straightforward. When a rat touches the FSR, the FSR will sense some pressure input with a specific value and send it to the microprocessor. In order to prevent false positives when the system may be triggered by some random forces other than the force applied by the rat's nose, a threshold to activate the dispensing system was set. According to the experiment conducted to investigate the force exerted on the FSR when a rat approaches the nozzle, we set the threshold value to be 150, which is high enough to ensure the stability of system. If the force applied reaches the threshold, the two servo motors will be activated at the same time, both rotating forward (counterclockwise on the left and clockwise on the right) and pull down the fishing wire threads through the plastic top over the canister.

The pulling process takes two seconds, which is enough to shorten the wire to a certain length to exactly press down the canister for one puff. Immediately after the two-second pulling-down, the servo motors will rotate in the opposite directions for the same amount of time. This reset the plastic top to the original position; then, the system is ready for the next use.

5.2.2 Circuit

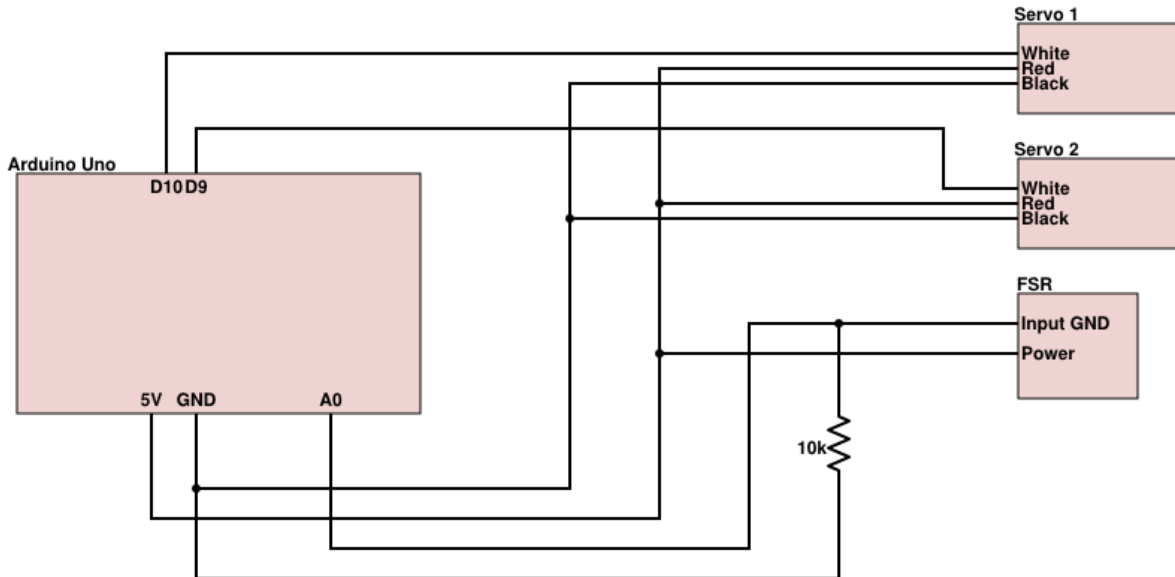

Figure 8. Circuit Schematic of the Automated System

Our team chose the Arduino Uno for our microprocessor because Arduino has many open coding sources and is relatively cheap in the market. The microprocessor is powered by external power source via a USB connector. The FSR and two servo motors are powered by the 5V pin and grounded on the GND pin on the Arduino. The FSR is connected to the analog input pin A0 on the Arduino with a 10k-ohm pull-down resistor. The two servo motors are connected to the digital pin D9 and D10.

6.0 Testing and Analysis

Several measurements had to be quantified to ensure success in this project. The first of these key quantifications was finding the dimensions of an average rat's mouth to accurately size the nozzle. The data found by measuring the oral cavities of two euthanized rats can be seen below in Table 2 (continued on the next page).

	Rat 1	Rat 2
Mouth width while open (mm)	2.5	3.1
Mouth height while open (mm)	4.5	4.7
Natural mouth width (mm)	6.0	6.1

Snout length (mm)	12.5	12.6
Snout height (mm)	9.2	10.9
Tip of snout width (mm)	5.7	6.8

Table 2. Dimensions of Rats' Mouths

Next, the amount of force that rats are able to apply to an FSR with their noses was needed for the Arduino code. Since the rats would destroy a loose FSR placed in their cage, this measurement was quantified by placing an FSR against the end of a bendy straw as a rat pushed on the other end of it rather than finding the force applied directly by their noses. The force applied by the rats could then be found by finding the difference between the FSR readings when the rats were pushing and the initial FSR reading due to pressure applied by the bendy straw. Results from two of the trials are shown below in Figure 9. While analyzing these results to determine the threshold force to include in the Arduino code, only the highest force applied in each trial was taken into account to ensure the sensor isn't too sensitive and dispenses medicine when a rat's mouth is not in position on the nozzle.

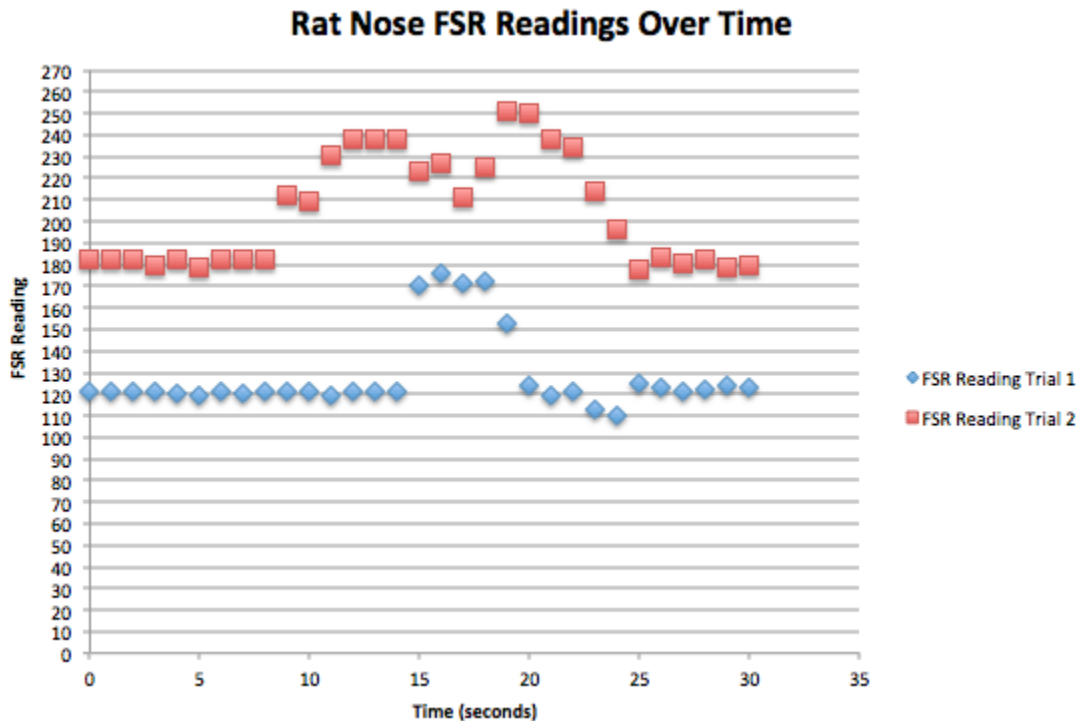

Figure 9. Forces Applied by the Rat's Nose (Two Trials)

Another measurement needed in this project was the amount of force needed to depress the inhaler canister, which was supposed to be found using an MTS machine. However, before this test was carried out, the MTS on campus broke; thus, a sufficient force to depress the inhaler was found through trial and error instead.

To determine the prototype's accuracy, the weight of medicine dispensed by an inhaler with the modified nozzle was compared to that dispensed by an inhaler without it. This was done by administering a puff of medicine into a bag of air placed on a sensitive scale. While the amount dispensed by the modified nozzle inhaler was consistently found to be about 1.3 mg, an accurate measurement of medicine dispensed by an inhaler without the modification could not be obtained, leaving the team with no baseline to compare the amount dispensed by the prototype to.

The prototype has yet to be tested with rats. To prepare them to use it, several rats in our client's lab have been trained over the course of the past semester to place their mouths around a bendy straw, so the team is hopeful that the transition to training them to utilize the prototype should be natural and straightforward.

7.0 Future Work

7.1 Testing

Now that the system is fully functional, the clients are able to run their experiments how they wanted. If certain components of the design prove to not work well for whoever runs the experiment or the rats don't respond as intended, modifications to the design will need to be made. One modification to the system that the client expressed interest in was finding a way to speed up the automation systems so the medication would be dispensed faster than the current rate of about two seconds, since they fear the rats won't keep their mouths over the nozzle for that long. Since the speed of our current design is limited by the maximum speed of the servo motors, an entirely new automation system design would be needed to achieve a faster release of the medication.

7.2 Nozzle Fabrication

The clients have also mentioned the possibility of them wanting nozzle designs that vary in size for testing on rats of differing ages and sizes for their experiments. Since the current nozzle is designed for use by an average sized rat, future nozzles would most likely be scaled down in size for testing on younger rats. All future nozzles will most likely be fabricated with 3D printing, since it is much faster and easier than fabrication from scratch in the machine shop.

7.3 Other Modifications

Several other modifications to the design could also be made for the future, both functional and aesthetic. Certain functional components we could manipulate include the use of different sizes, shapes, and force calibrations for the force sensitive resistors. Different FSRs could possibly work better for certain experiments the client may run in the future, and recalibrating the force needed to activate the FSR will most likely need to be done for testing on rats of different ages and sizes. Aesthetic changes to the final design could include using a different, sturdier material for the wire, as well as making the containment unit more protective of the design components and more visually appealing.

7.4 Medical Applications;

After completion, it became apparent that the design is essentially a remotely activated MDI medication dispensing system. The team realized that with a few modifications, a system like

this could have applications in the medical world as a way for people who couldn't normally compress a regular MDI canister, like people on bed rest with limited mobility or severe arthritis, to use an inhaler themselves by lightly touching an FSR.

8.0 Conclusion

The client was satisfied with the nozzle that was designed to modify a traditional metered dose inhaler for use by rats. More nozzles of the same size can be 3D printed, and it is possible to manufacture different sizes as well. The automation system, consisting of an FSR, arduino, and two servo motors, was proven to work during human testing by pressing the FSR and medicine dispensing from the inhaler. However, testing still must be completed with rats and additional training will likely be necessary.

9.0 Acknowledgements

We would like to thank our clients, Dr. Mihaela Teodorescu and Dr. Oleg Broytman, for the opportunity to work on this project. We would also like to thank our advisor, Dr. Jeremy Rogers for his support and guidance throughout the course of this semester, and Dr. John Puccinelli for helping us get access to resources that were needed over the course of the semester.

10.0 References

- [1] Fuerst, M. (2014, March 12). Corticosteroids for Asthma Raise Sleep Apnea Risk. Retrieved October 8, 2014. <http://www.psychiatrictimes.com/sleep-disorders/corticosteroids-asthma-raise-sleep-apnea-risk>
- [2] Mayo Clinic Staff. (2012, July 24). Mayo Clinic - Diseases and Conditions. Retrieved from <http://www.mayoclinic.org/diseases-conditions/sleep-apnea/basics/definition/con-2002086>
- [3] Organs and Structures of the Respiratory System. (n.d.). Retrieved November 5, 2014, from <http://philschatz.com/anatomy-book/contents/m46548.html>
- [4] "PROAIR HFA (albuterol sulfate) Inhalation aerosol." Retrieved October 7, 2014. <http://dailymed.nlm.nih.gov/dailymed/archives/fdaDrugInfo.cfm?archiveid=9192>
- [5] Cohn, L. (2009, July 1). Inhalant therapy: Finding its place in small-animal practice. Retrieved September 20, 2014, from <http://veterinarymedicine.dvm360.com/inhalant-therapy-finding-its-place-small-animal-practice>
- [6] Sorkness, R., Remus, J., & Rosenthal, L. (2004). Systemic and pulmonary effects of fluticasone administered through a metered-dose inhaler in rats. *Journal of Allergy and Clinical Immunology*, 1027-1032.

[7] Oglesbee, B. (2011). *Blackwell's five-minute veterinary consult: Small mammal* (2nd ed., p. 598). Chichester, West Sussex: Wiley-Blackwell.

11.0 Appendix

11.1 Costs: Weekly Expenses

Date:	Item:	Cost:	Comments:
9/11/14			No costs to report
9/18/14			No costs to report
9/25/14			No costs to report
10/2/14			No costs to report
10/9/14	Laboratory Rat (x 2)	\$141	2 rats at \$70.50 each
10/16/14	Rat Housing (weekly)	\$4.92	Housing 10/13 – 10/16
10/23/14	Rat Housing (weekly)	\$8.61	Housing 10/17 – 10/23
10/30/14	Rat Housing (weekly)	\$8.61	Housing 10/24 – 10/30
10/30/14	Ordered plastic	\$42.13	
10/24/14	Servo motor, Arduino, and FSRs	\$58.42	
11/6/14	Rat Housing (weekly)	\$8.61	Housing 10/31 – 11/6
11/13/14	Rat Housing (weekly)	\$8.61	Housing 11/7 – 11/13
11/7/14	Servo motor, Arduino, and FSRs	\$52.43	Second order
11/20/14	Rat Housing (weekly)	\$8.61	Housing 11/14 – 11/20
12/4/14	Rat Housing (weekly)	\$17.22	Housing 11/21 – 12/4

Total Cost: \$359.17 Budget: \$1000.00

11.2 Timeline: Project Schedule

Task	September			October					November				December	
	12	19	26	3	10	17	24	31	7	14	21	28	5	12
Project R&D														
Manufacturing									X	X	X	X	X	
Rat Training					X	X	X		X	X				
Prototyping			X	X	X									
Cost Estimation			X	X	X	X	X	X	X	X	X			
Deliverables														
Progress Reports	X	X	X	X	X	X	X	X	X	X	X	X	X	
PDS	X		X											
Mid-semester			X	X										
Final										X	X	X	X	X
Meetings														
Client		X			X		X							
Team	X		X	X	X	X	X	X	X	X	X	X	X	X
Advisor	X	X	X	X	X		X	X		X		X		
Website														
Update	X	X	X	X	X	X	X	X	X	X	X	X	X	X

Filled boxes = projected timeline

X = task was worked on or completed

11.3 Product Design Specifications

1. Client Requirements

- The mouthpiece should be made of a material that can withstand rat bites
- The mouthpiece should be made of a material that propellant medicine will not adhere to
- The nozzle should be detachable and designed in several different sizes
- The material of the mouthpiece should have the capability to be squeezed, similar to the action of getting peanut butter out of a straw
- An automated system should also be designed so that when the rat operates the mouthpiece, a puff is automatically dispensed from the inhaler
- The material needs to be able to undergo sterilization
- The design should cost under \$1000
- Replicates should be made for training purposes
- A way to train the rats to use the nozzle must also be devised and tested

2. Design Requirements

2.1. Physical and Operational Characteristics:

a. Performance Requirements:

The design should consist of a detachable piece that fits on the end of a typical metered dose inhaler with a nozzle on the end that could fit in the mouth of a rat. The nozzle must deliver the drug directly into the rat's oral cavity, allowing the medicine to deposit on the tongue and mouth. In this manner, the method of delivery must be as similar as possible to use of an MDI by a human. The nozzle must be able to withstand multiple uses, including wear and tear from rats who will gnaw on the material. It also must tightly fit to the MDI, allowing little to no medicine to escape.

A training system for use of the nozzle by rats must also be devised. The rats must willingly place their entire mouth over the nozzle with their teeth out of the way when the medicine is dispensed. It is crucial for the medicine to deposit on the tongue and mouth of the rat(s).

The system should also be automated so that when the rat places its mouth around the nozzle and bites, the drug will be dispensed into the oral cavity.

b. Safety

Since the product will be used with living rats, it must be composed of a material that is non-toxic to rats. The design of the nozzle must also be durable enough as to minimize the risk of a choking hazard to rats, considering that the rats will bite and gnaw on the nozzle. The nozzle also must be made of a material that is compatible with the medicine and sterilization methods, and not cause any toxic by-products.

c. Accuracy and Reliability

The product must be able to withstand multiple uses and accurately deliver the drug. It must fit tightly on the existing mouthpiece of the MDI and be made of a material that particles will not adhere to so that the majority of the drug is deposited in the oral cavity of the rat.

d. Life in Service

The nozzle will be used multiple times with different rats so it must be durable.

e. Operating Environment

The nozzle and MDI system will be placed in a cage, allowing the rats to operate the system themselves. A researcher will be observing the environment, but will not place the nozzle in the rat's mouth or operate the MDI to dispense the drug.

f. Ergonomics

The nozzle must fit comfortably in the oral cavity of a typical lab rat, but also be available in multiple different attachment sizes, as mouth size varies with age.

g. Size

The nozzle must be small enough for the rat to get their mouth around it enough to get a sufficient spray of medicine into its oral cavity. Several sizes should be manufactured to account for differences in rat size as they age.

h. Weight

The product should be lightweight and remain tightly attached to the mouthpiece.

i. Materials

The nozzle should be made of a material that is similar to the plastic of the existing mouthpiece on a traditional MDI. Specifically, it should be made of a material that the medicine will not easily adhere to and can withstand gnawing by rats.

2.2 Production Characteristics

a. Quantity

Multiple nozzles should be designed and manufactured, incorporating different sizes for use on aging rats. Replicates for use in training and testing should also be created.

b. Target Product Cost

The nozzle and automated system should cost under \$1000.