

# Final Report - Continuous Monitoring of Asthma Control

---

BME 200/300 - Fall 2016

Client: Dr. Sameer Mathur, MD, PhD - School of Medicine and Public Health  
Advisor: Professor Willis J. Tompkins, PhD - Department of Biomedical Engineering

Team Members:  
Leader: Tim Lieb  
BSAC: Luke DeZellar  
Communicator: Luke Le Clair  
BWIG: Ryan Opansky  
BPEG: Roberto Romero

**12/14/2016**

This project entails creating an efficient and accurate method of continuously monitoring asthma symptoms in severe asthmatic patients. Currently, the symptoms of an asthma exacerbation are not sensed by the patient until days after the exacerbation has begun. Delayed diagnosis of an exacerbation results in a delayed start to the patient's asthma action plan (AAP). This can mean extra trips to the clinic or hospital for something that was treatable at home only a few days prior. The implementation of a continuous asthma monitoring shirt will alert patients to begin their AAP before needing to make unnecessary trips to the hospital, thus saving a large portion of hospital resources that are being used on asthma related visits. Our team decided to focus on creating one functioning microphone with the ability to distinguish between normal speaking, coughing, and wheezing. Previous attempts have been made to detect these asthma symptoms by introducing multiple microphones directly into a shirt, however, problems with interference were encountered due to the numerous elements. These previous attempts resulted in no useable data for future teams to build upon. Our team decided to focus on developing a single microphone in order to obtain accurate data that can be built upon as the design progresses through future semesters.

# Table of contents

Introduction.....	3
Background.....	4
Preliminary Designs.....	5
Preliminary Design Evaluation.....	7
<i>Materials</i> .....	9
<i>Methods</i> .....	9
<i>Final prototype</i> .....	10
<i>Testing</i> .....	12
Results.....	13
Discussion.....	16
Conclusions.....	17
References.....	19
Appendix 1.....	20
Appendix 2.....	21
Appendix 3.....	24
Appendix 4.....	26
Appendix 5.....	28
Appendix 6.....	30
Appendix 7.....	31

# Introduction

In the United States alone, approximately 26 million people suffer from asthma with related costs estimated to be \$60 billion annually [1]. There is no cure for the disease, so patients must treat their symptoms continuously in order to keep them under control. In recent years, there has been an increase in the number of asthma diagnoses, and with that, an increase in severe asthma patients [2]. These severe asthma patients, while only 5-10% of total asthmatics, have symptoms that are more intense and more frequent compared to an average asthma patient. Consequently, this small population accounts for a disproportionate amount of health-care costs, hospital admissions, doctor visits (both scheduled and unscheduled), and emergency services [2]. Asthma patients have asthma action plans (AAP) in place to treat asthma exacerbations before they become too severe, but many times the symptoms are not felt for a couple of days (AAP protocol is listed in Appendix 7). An AAP is a procedure for a patient to follow in the event of an asthma exacerbation. Our device will allow the symptoms of these asthma exacerbations to be detected earlier, notifying the patient to begin their AAP sooner, saving both time and resources for the patient as well as saving hospital costs.

Currently, there are no devices that can continuously monitor asthma symptoms and alert patients when an asthma exacerbation has started. Often, a spirometer test is used to assess an individual's asthma severity and lung function. An example of a spirometer is given by patent US6238353 [3]. One measurement commonly taken from spirometry is FEV<sub>1</sub>, or forced expiratory volume in 1 second [4]. It uses the maximum amount of air an individual can forcefully exhale in 1 second in order to gauge lung function [5]. This is often done in a clinic during check-ups or when a patient starts to feel an exacerbation. In home spirometer tests do exist, but these are less common, do not measure continuously, and are typically used after symptoms are felt.

The previous team's approach to measure asthma symptoms included two microphones to listen to the lungs and two resistor bands to measure breathing rate and lung function. These components were built into a shirt, and an Arduino was used to collect the data and send it to LabVIEW. We were unable to build off of their current device because it could not collect usable data. Their device/circuit had many components, which caused interference to occur across multiple elements. This, along with trying to measure too many signals at once, led to them getting no useable data from any of their tests. As a result, we decided the best approach would be to focus on one aspect of the shirt and obtain reliable data from that one signal.

The main asthma symptoms, wheezing, coughing, and increased respiratory rate, are often not experienced by the asthma patients for a couple of days after they start. This is due to the fact that the initial changes can sometimes be very minor and indistinguishable to the patient from their normal breathing habits. A device that could detect these symptoms sooner would lead to faster implementations of AAPs. While the target patient for a device such as this would be a small percentage of asthmatics (those with severe asthma), they use a large portion of the medical resources. If a device could be made to alert the severe asthma patients to the onset of an asthma exacerbation sooner, it poses the potential to save significant amounts of time, money, resources, as well as potentially decreasing the severity of the asthma attack.

## Background

Asthma is a chronic condition characterized by inflammation and narrowing of the bronchial tubes in the lungs [2]. The air travels to the bronchioles, which are the smaller tubes that branch off from the larger bronchi. Both the bronchi and bronchioles have mucus lining in interior walls, which, along with cilia, help keep the lungs, clean of debris. At the end of the smallest bronchioles, the air enters the alveoli. Alveoli are small, hollow spheres of thin tissue with capillaries surrounding them. The alveoli are epithelial cells that facilitate and expedite the process of gas exchange. An individual with severe asthma has bronchi and bronchioles that are consistently inflamed. This limits the amount of air that can enter the lungs and inhibits lung functions. When a person's asthma is triggered, the bronchi and bronchioles constrict and can become increasingly inflamed [6]. This constriction leads to, in many cases, increased breathing rate from the decrease in the allowed air intake. In addition, their body sends out an immune response due to the allergen/irritant that triggered their asthma exacerbation. Their body's T helper cell type 2 (Th2) cells release cytokines, which in turn produce and release histamines and cysteinyl leukotrienes. These contract the smooth muscles in the airways and promote mucus production. This cell response leads to bronchospasms, edema, and increased mucus secretion, all of which are the characteristic symptoms of asthma [7]. The excess mucus builds up in the lungs makes it even harder for the patient to breathe and sometimes includes a phlegm-sounding cough [6]. The recognition of these combined symptoms leads to the patient to initiate their AAP. As the exacerbation progresses, breathing becomes increasingly difficult and the performance of the respiratory system suffers drastically. The respiratory system is responsible for supplying oxygen to red blood cells while simultaneously removing carbon dioxide from the body. When the respiratory system does not work correctly, the lack of oxygen can cause major issues [8]. A complete lack of oxygen (anoxia), or even a decrease in oxygen (hypoxia), can be fatal. Asthma is responsible for 3,300 deaths annually in the United States alone [1]. Even just four minutes without sufficient oxygen to the brain can cause brain cell death, and the results can be permanent.

There are four main symptoms of asthma: coughing, wheezing, chest tightness, and shortness of breath [1]. Nevertheless, the specific symptoms felt and their severity can vary widely from one individual to the next. Unfortunately, this can cause the disease to go unrecognized, under-diagnosed, and undertreated [9]. Asthma severity can greatly increase due to poor or inconsistent treatment, which makes the asthma much more difficult to control and treat [2]. An asthma exacerbation is an acute worsening of the disease. Often, asthma triggers are responsible for the attack. These triggers can be airborne such as pollen, pet dander, mold, smoke, and chemical fumes [1]. Other triggers include sickness (often the cold or flu), exercise and stress. When asthma exacerbations occur, the symptoms may not be felt by the patient for a few days. This causes the symptoms to worsen and makes treatment more difficult.

For severe asthma patients, approximately the top 10% of the total asthma population, asthma exacerbations can be more common and their symptoms more extreme [2]. Even after the asthma is under control, it can take up to a month for the patient's lung function to return to normal. This heightened airway inflammation and extended recovery time can take a toll on the bronchi. The continuous tissue destruction and airway remodeling in severe asthma patients

creates a “chronic wound” with ongoing epithelial injury and repair [2]. Over time, these conditions can lead to thickened and stiffer airways, which are more resistant to anti-inflammatory drugs. This demonstrates that the damage from asthma exacerbations can last long after the asthma is under control.

Asthma cannot be cured, so the best way to fight it is through prevention. Dr. Sameer Mathur is an allergist working at the UW-Madison School of Medicine and Public Health. He believes that if the symptoms of an asthma exacerbation can be detected even before the patient feels them, the exacerbation can be treated more quickly and easily which could ultimately reduce the number emergency room visits, hospital admissions, and even deaths. The goal is to create a wearable “asthma shirt” that will be able to detect various lung sounds that are characteristic of asthma-- specifically coughing, wheezing, and respiratory rate. With the guidance of Dr. Mathur, the team was able to come up with specific produce design specifications. The full PDS can be found in Appendix 2, but a few important features are noted below.

The device created must be able to accurately and reliably detect the different asthma sounds of the lungs. This is crucial to ensuring the results are precise and consistent. The device will be integrated into a shirt. At this stage, the size, weight and aesthetic are not important parameters of interest at this time. Ideally, the device will be as small and light as possible so it does not cause discomfort to the patient. The shirt should appear as similar to a normal shirt as possible so the patient is comfortable wearing the device. The shirt will be in direct contact with the patient, so the material of the shirt and the device should be safe on the skin. In addition, the device should be able to run for at least four hours at a time for testing. Eventually, the device will need to run 24/7. The group has a pre-approved IRB protocol that allows the shirt to be tested on asthma patients undergoing methacholine tests. These tests last approximately four hours and hence, the device should run for at least that amount of time. Dr. Mathur’s long-term goal is to develop a shirt with multiple components that will be able to be worn 24/7, however, he expects us to design a simplified device that will work in testing situations. More protocol specifics will be discussed in the Testing section of this report.

## **Preliminary Designs**

The first design that we considered was a thermistor mask. This mask would include a thermistor within voltage divider that feeds into a non-inverting amplifier, and the final output would be fed into a microcontroller. This circuit would be contained within a housing attached to the mask, and the thermistor would be placed inside of the mask. Due to the variability of a thermistor’s resistance as the external temperature changes, the output voltage would change in a predictable way depending on the temperature within the mask. This would allow us to accurately predict the breathing rate of the patient. As the patient’s breathing rate increases, the temperature inside of the mask would increase, and the opposite as the breathing rate decreased. Since the mask is only able to take measurements based on temperature, coughing and wheezing

data would not be obtainable. Figure [1] in Appendix 1 gives an example of the type of mask that would contain the thermistor and circuit.

The next design that we considered was an asthma shirt with built in microphones to detect the asthma symptoms. The two wired microphones would be placed over the patient's lower back. Although two microphones could complicate the analysis of the data, it is necessary to take readings from both of the patient's lungs as each lung could have different lung sounds. These microphones are then fed into LabVIEW for post analysis. The group will then create predetermined thresholds of frequency for coughing, wheezing, and respiratory rate. The recorded data from the patient would then be compared to these thresholds to determine whether the patient is showing signs of an asthma exacerbation.

The third, and final design, would replace the microphone from the previous design with an electronic stethoscope. The same thresholds would then be determined for the asthma symptoms and compared to the data that is recorded by the electronic stethoscopes to determine if the patient is having an exacerbation. Figure [2] in Appendix 1 gives an example of how the microphones and electronic stethoscope would be incorporated into the asthma shirt.

# Preliminary Design Evaluation

Design Criteria (weight)	Thermistor Mask		Microphone		Electronic Stethoscope	
Patient comfort (25)	2/5	10	4/5	20	4/5	20
Effectiveness (20)	2/5	8	4/5	16	4/5	16
Ease of Use (20)	2/5	8	4/5	16	4/5	16
Cost (15)	5/5	15	5/5	15	1/5	3
Adjustability (10)	3/5	6	4/5	8	3/5	6
Safety (10)	4/5	10	5/5	10	5/5	10
<b>Total</b>		<b>55</b>		<b>85</b>		<b>71</b>

Figure [1]: Design Matrix comparing the preliminary design ideas

## Proposed Final Design: Microphone

*Patient Comfort* is defined as the level of comfort in the overall experience of using the device. We chose this as a criterion because the device is being created for use in the patient's everyday life. In order to obtain useful data, the device must be worn for at least four hours per day. Due to its frequency of use, the patient's overall comfort level is extremely important, thus justifying our highest overall weight. We gave both the electronic stethoscope and the microphone a score of 4/5. For both of these devices, the patient will have readings taken from either their back or chest areas. They both received such a high score due to the minimal discomfort that would be necessary to take breathing readings. The thermistor mask would collect data by being placed over the mouth of the patient while they are breathing, creating a higher level of discomfort. For this reason, the thermistor mask received a score of 2/5.

*Effectiveness* is defined as the accuracy with which the design will be able to capture information related to asthma symptoms. We gave effectiveness a weight of 20, which is tied for our second

highest weight. This category was included because accurate and effective data collection is extremely important in the diagnosis of these asthma symptoms. The thermistor mask received a score of 2/5 due to the possibility of complications related to the ambient temperature that could come from other external sources. Also, the thermistor mask could only be used to measure breathing rate. The microphone received a score of 4/5 and was tied for our highest score because it can effectively measure the sound of someone breathing and has the potential to block out ambient noise with the use of thresholds in the post-analysis. The electronic stethoscope received a score of 4/5 as well because electronic stethoscopes effectively detect breathing sounds while canceling out ambient noise.

*Ease of Use* is defined as the ability of the design to be implemented effectively. It is crucial that a wide number of patients and doctors are able to use the device easily and efficiently. Due to its importance in the success of the product, this category also received a weight of 20. The thermistor mask was given the lowest out of all with a score of 2/5. While the mask does produce results, its use is cumbersome and invasive, not allowing the patient to perform everyday tasks while data is being taken. The microphone and the electronic stethoscope were both tied for the highest with a score of 4/5. In both cases, the design would be built into a shirt. The patient only needs to put on the shirt in order to start using it, making it very easy to use. At this point, the system would still need to be hooked up to a computer instead of being wireless, which is why they did not receive a full 5/5.

*Cost* is defined as total expenses needed to create the device. This category received a weight of 15, which is one of the lower scores. Due to the limited funds available for this project, cost is a constraint on our design, but nevertheless we felt other categories were more important to the design. The thermistor mask and microphone received perfect scores of 5/5. These designs would be the cheapest to make since they consist of various inexpensive pieces. Lastly, the electronic stethoscopes received a score of 1/5, since it is by far the most expensive. The cost of these instruments is much greater than the other designs, and therefore they were assigned the lowest score.

*Adjustability* is defined as the amount of change we can make in our design to fit our patients needs. This includes where we can put the device on the patient and our ability to move it or adjust is for better comfort or usefulness. We gave it a weight of 10 because it once you have it on, it shouldn't need to move. We chose this category because it is important for the device to be adjustable because the better the fit, the better data we can record. We gave the Thermistor mask a 3/5 due to the lack of customizability of a standard facemask to add to the patient's comfort. The microphone received a score of 4/5 because we will be designing the housing and shirt for the patient to wear. This gives us a tremendous amount of ability to move things around and play with where everything goes. The electronic stethoscope received 3/5 because we have to buy an already made stethoscope. This doesn't allow us as much design freedom because we have to follow whatever specifications come along with the stethoscope.

*Safety* is defined as how likely the patient would be able to perform the diagnosis without being harmed. We gave safety a weight of 10 because we believe that none of these designs would cause the patient any serious pain or would be dangerous. We still want to consider the patient's safety because this is a medical device that the patient will use extensively and we want to minimize the potential for the patient to be injured. We gave the thermistor mask a 4/5 because it



covers the patient's face and if the patient has a hard time breathing this might make it even harder for the patient to breath. We ranked both the microphone and the electronic stethoscope a 5/5 because it does not pose a great safety threat. The patient will not be in direct contact with the circuit, so even if it were to fail, the patient would not be harmed.

## **Fabrication/Development Process**

### ***Materials***

The materials will consist of a microphone, shielded cable with two conductors, 3M Littmann lightweight stethoscope, Arduino microcontroller, a rubber bulb from a blood pressure cuff, National Instruments USB-6002 Data Acquisition device, and the LabVIEW program. Images and costs for all of these materials can be found under Appendix 3. For a microphone we used the Sparkfun MEMS Microphone Breakout-INMP401 (Figure [1]) with a built in amplifier. The microphone is powered by 3.3 V and has a peak-to-peak output of 200 mV. We used this microphone because of its ability to detect low frequency physiological signals and its built in amplifier. A two conductor shielded cable (Figure [2]) was used in our design due to its ability to limit the effects of electromagnetic interference (EMI). When we are analyzing physiological signals with such small amplitudes, any amount of interference could misdiagnose a patient; so limiting this interference will improve the accuracy of the device. In order to capture the signals from the patient, we utilized a 3M Littmann lightweight stethoscope (Figure [3]). Although we are not implementing any code with it, we used the Arduino microcontroller (Figure [4]) solely to power the microphone with its 3.3 V output. The rubber bulb from a blood pressure cuff was used to house the microphone and shield it from ambient noise. In previous semesters, filters were assembled on a breadboard in order to analyze the breathing data. One of the reasons that they did not have success with this method was the amount of interference that was created by filtering numerous signals through this circuit. To avoid this problem, we used a National Instruments USB-6002 Data Acquisition device (Figure [5]). The benefit of using this device is avoiding any additional circuitry, due to the signal processing functions available in LabVIEW, and its ability to output multiple analog signals for analysis. The version of LabVIEW that we have access to is LabVIEW 2010. In order to use the data acquisition device we must download, and run, the NI-DAQmx 9.9 extension for LabVIEW. A list of all materials and expenses can also be found in Appendix 3.

### ***Methods***

To begin the fabrication, we strip 2-inch sections of shielding from each end of the shielded cables and .5 inches from the ends of the conducting wires. The wires are then soldered to the small connections of the microphone to ensure that there is no crossing of wires within the rubber bulb housing. After removing the earpiece from the stethoscope, the open end of the stethoscope is inserted into, and secured to, one end of the rubber bulb. The microphone is then inserted into the other end of the rubber bulb and secured to ensure that it would not move within the housing. The exposed conducting wires are then connected from Arduino ground to microphone ground, Arduino 3.3 V output to microphone power, and analog input of the DAQ device to the output of the microphone. Finally, the NI DAQ device is connected via USB to the computer that is running the LabVIEW 2010 program.

### *Final prototype*

The final prototype is shown below in Figure [2].

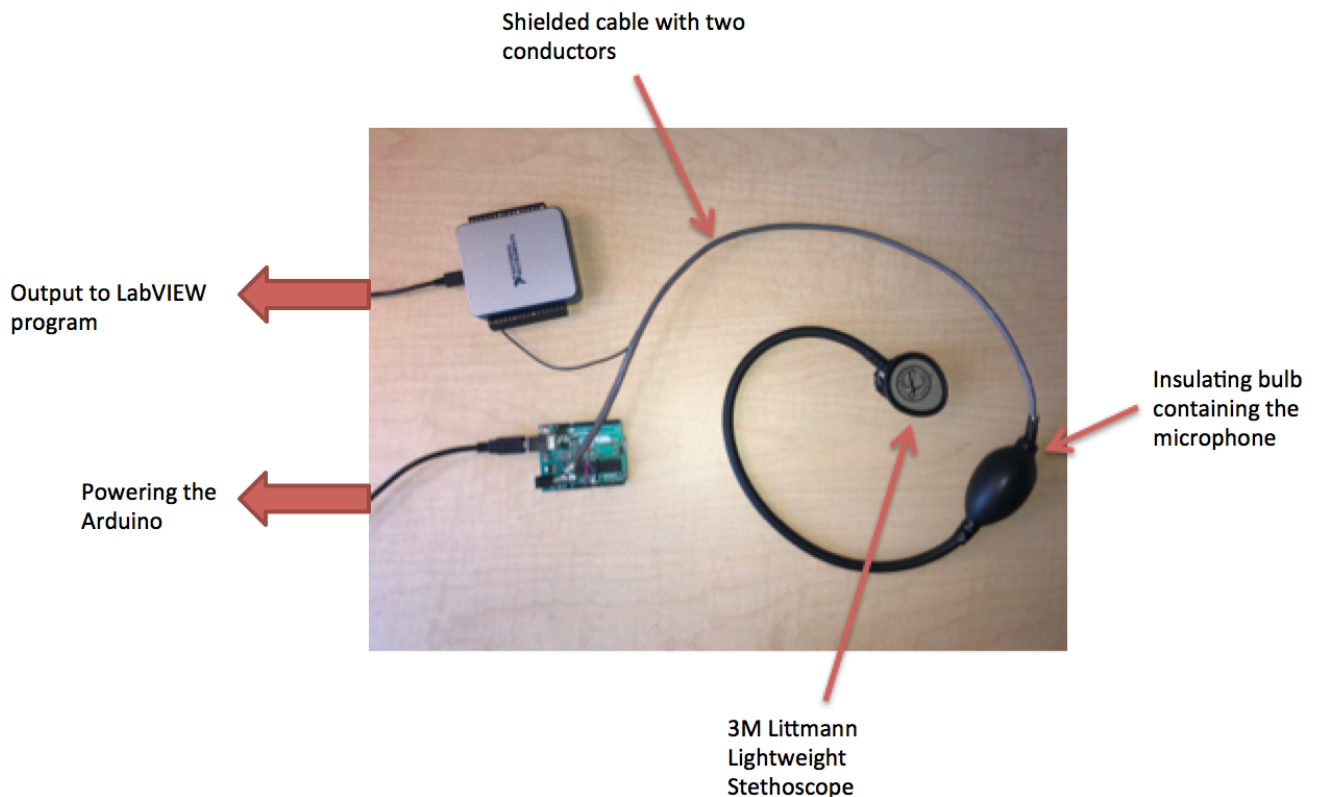

Figure [2]: Final Prototype

Along with the final prototype for the device, we also have a final prototype for the block diagram that we use to process the data in LabVIEW. This block diagram is

shown below in Figure [3]. The first function that we have is the DAQ Assistant, which takes the data from the analog input of the DAQ device and allows it to be analyzed. We then feed the raw data through a series of filters, the first being a low pass filter with a corner frequency of 5 Hz and the second being a bandpass filter with corner frequencies of 20 and 40 Hz. The low pass filter is used to distinguish normal breathing from wheezing in an asthmatic patient, while the bandpass filter is used for distinguishing coughing from talking, ambient noise and normal breathing. Next, the filtered data are fed into two different charts to display the live output of the microphone. Another function that we use to display our data is Spectral Measurements. This allowed us to display the frequencies of the raw and bandpass filtered data in real time. These functions then feed directly into separate graphs for display to the user.

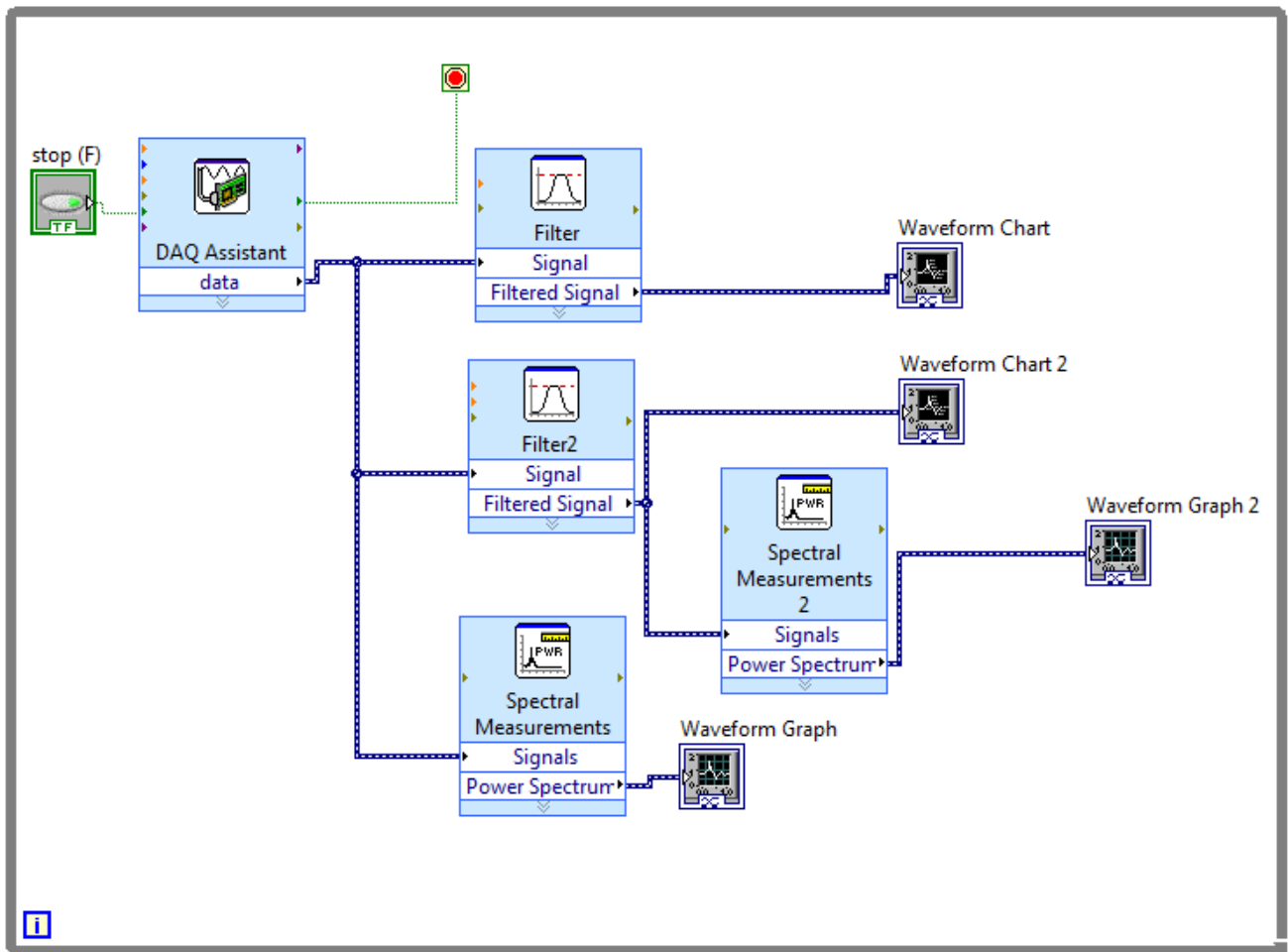

Figure [3]: Final LabVIEW Block Diagram

## *Testing*

The first tests we performed were using the National Instrument- DAQmx 16.0 software that comes with the DAQ. Images for the output and the setup for this part of the testing can be found in Appendix 4. After installing the software on a computer in the lab, we used the Test Panel for preliminary testing to better understand the functions and the variability of the DAQ. First, we connected the output from a waveform generator to the analog input of the DAQ. The DAQ is made to handle two different types of analog inputs: differential and single-ended. Differential gathers a signal based on the difference between two analog inputs while single-ended just uses the analog input from one channel. For this project, we used the single-ended input configuration because we just have one signal coming from the microphone. To start, we used a sine wave at varying frequencies and voltages to observe how these influenced the output on the Test Panel. Next, we used a potentiometer with varying resistance to test the DAQ. We wanted to see how the device reacted to sudden, unpredictable analog changes. We fed the 5 V output from the DAQ through the potentiometer and turned the knob to change the resistance/ the output data. The setup for this test can be found in Appendix 4 (Figure [1]). Finally, we wanted to test the DAQ using the microphone. We used an Arduino to supply the 3.3 V to the microphone and the analog signal was fed into the DAQ (Figure [2]). We snapped close to the microphone to see how the data was picked up and how it was displayed on the Test Panel.

The next part of our testing used our built prototype and the LabVIEW program. During this part of the testing, our microphone was encased in a small, plastic piece instead of the final rubber bulb. We ran the data through a LabVIEW filter before displaying the output on a waveform chart. We experimented with various low-pass and bandpass filters at different corner frequencies. This was done in order to try and cancel out ambient noise and isolate important lung sounds. The output from this testing will be discussed in further detail in the results sections, but ambient noise was an issue during this testing.

The team replaced the plastic casing with a rubber bulb since rubber is a better insulator for audio signals. The next set of testing was done with this new prototype. We added more functions to the LabVIEW program in order to better analyze the data. The LabVIEW used for this part of the testing is the same as previously discussed in the final prototype. We tested different corner frequencies for the low-pass filter in order to try and isolate the low frequency breathing noises. We sampled different frequency ranges for the bandpass filter in order to try and capture coughs. Also, we used two waveform graphs in order to see the frequency of the audio signal in real time.

The last part of the testing used the same methods just described, but we added an amplifier to the system. We built a non-inverting amplifier using a TLV-272 operational amplifier. The feedback resistance was 330 ohms and the resistor going to ground was 220 ohms. This created a gain of 2.5 for the circuit. We ran the output from the microphone through the amplifier before putting it into the DAQ. We did this to see if we

could get more prominent peaks for the coughs and a clearer signal for the low frequency breathing.

## Results

The results from the first set of tests using the NI-DAQmx 16.0 software with the data acquisition device can be found in Appendix 5. The images show the Test Panel after testing with a sine wave from the waveform generator (Figure [1]), testing with the potentiometer (Figure [2]), and testing with the microphone (Figure [3]). In all three of the tests, the DAQ was able to quickly and accurately detect any changes in the analog input. This was helpful in getting accustomed with the DAQ and its functions as well as getting preliminary data using the microphone with the last test.

The next set of results comes from testing with the first prototype (using the plastic microphone casing). Appendix 6 shows images from the LabVIEW front panel during these tests. At first the data was unfiltered in order to see the nature of the different signals. Figure [1] shows the raw input from talking and Figure [2] shows the raw input from coughing. First, it is clear that there is a lot of ambient noise being picked up from the microphone. A lot of ambient noise will make the signal very difficult to analyze. In addition, talking created prominent peaks just like the coughs. Although the peaks from the coughs are more distinct, any talking picked up poses the risk of misdiagnosing asthma symptoms. The next part of this testing involved the use of filters. We sampled different types of filters and were able to get better results using a 20 Hz low-pass filter. Figure [3] shows the signal from talking using this filter. The talking is almost completely removed and any signal from the talking looks like background noise. In contrast, the coughs using this filter are still prominent peaks (Figure [4]). With this filter, we were able to isolate the coughs while essentially eliminating the signal from talking. With further testing, we noticed that the ambient noise was still an issue. Any noise made close to the microphone (such as snapping fingers or knocking on the table) was picked up as distinct, prominent peaks. While the data coming from the patient seemed alright, the background noise was interfering with the signal. This prompted the design change using the rubber casing instead of the plastic.

After changing the design, we tested the new prototype using LabVIEW. This time, we used two waveform charts to see the signal voltages and two waveform graphs so see the frequency in real time. Below is a picture of the LabVIEW front panel during this testing.

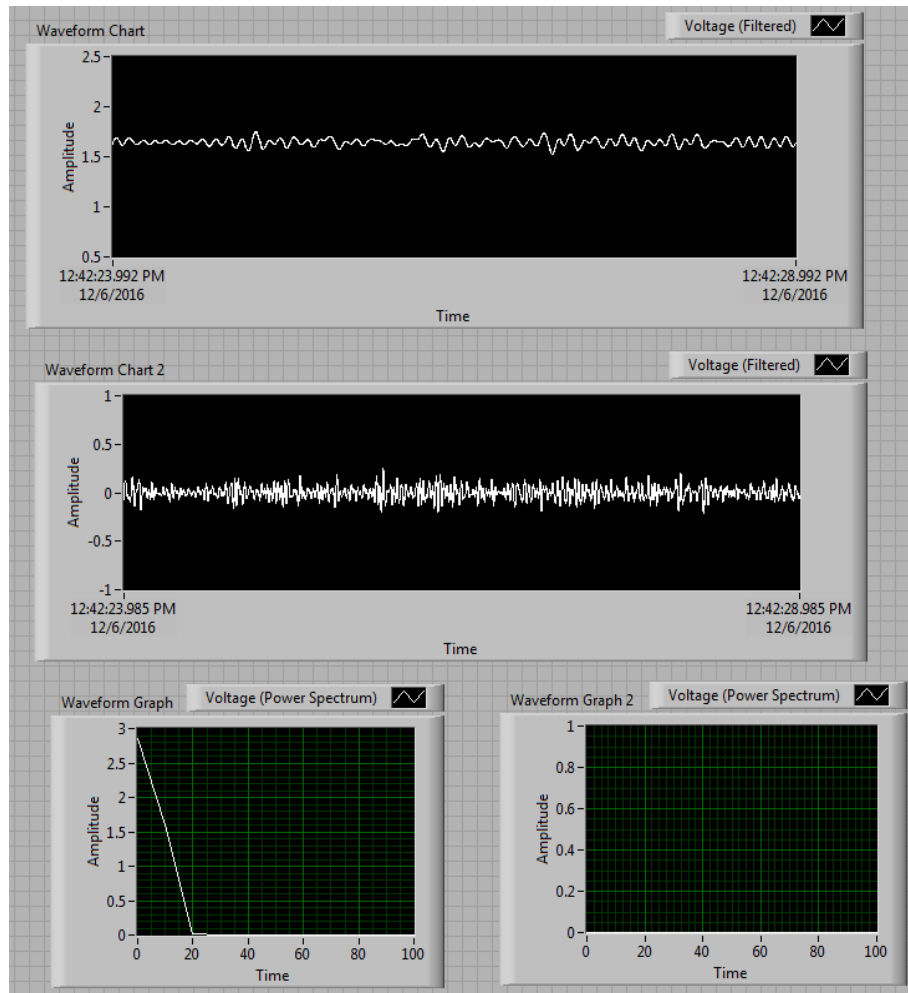

Figure [4]: Front Panel Normal Breathing Output

This figure shows the output from the microphone during normal breathing. The top chart is the 5 Hz low-pass filter and the one below it is the 20-40 Hz bandpass filter. These filters were able to remove essentially all ambient noise. The graph on the bottom left is the frequency of the unfiltered data while the one on the lower right is the frequency of the filtered data from the bandpass. These show that most of the signals coming from the lungs during normal breathing are between 0-20 Hz and there is nothing on the graph from the bandpass filter. With all this, the program was still able to pick up coughs by the patient. This is shown in the figure below.

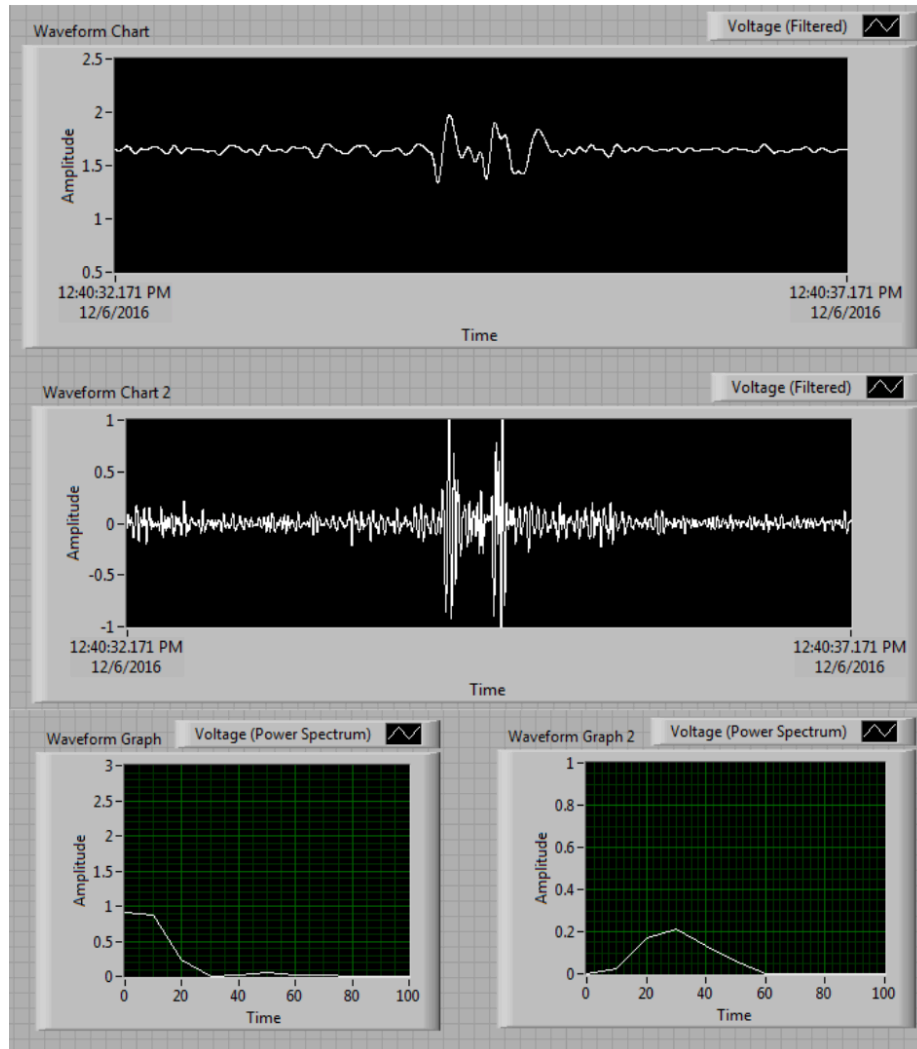

Figure [5]: Front Panel Coughing Output

The group was able to easily distinguish the coughing signals. This is most clearly seen in the middle waveform chart coming from the bandpass filter. Two coughs create distinct peaks that clearly stand out from the surrounding signal. This cough is also seen on the frequency graph coming from the bandpass filter. While there was no signal on this plot during normal breathing, here there is clearly a peak between 20 and 40 Hz.

The last part of the testing did not generate any usable results. When applying an amplifier along with the microphone, the team hoped to get more distinct peaks and a clearer signal from the low-pass filter. Instead, the data was shifted upwards and the top of the signal was clipped. Since the amplifier was being powered with the 5 V output of the DAQ, the signal generated could not be greater than 5 V. The baseline signal from the amplifier was around 4.5 V, and so many of the signal peaks would get cut off at 5 V.

## Discussion

In the past, design teams focused on many aspects of asthma monitoring at once, but ended the design process with no useable data for future teams to build upon. By taking this project one aspect at a time, our group was able to isolate coughing sounds from other signals, talking, ambient noise, etc. Coughing is one of the three main asthma symptoms that we hope to isolate using this microphone since continuous coughing indicates that the patient is in the early stages of an asthma exacerbation. That coughing will only worsen as the patient's symptoms progress. During normal breathing, speaking, etc. the majority of detected frequencies are located between 0 and 20 Hz. Through testing, our group was able to determine coughing created a peak signal that can be detected in the 20 to 40 Hz range. For this reason, we targeted that region with the bandpass filter. This data is useful to the monitoring of asthma symptoms not only because we were able to distinguish a person's cough, but also because we can apply this same concept to detect other symptoms.

Another major asthma symptom that the team hoped to detect is wheezing. Unfortunately, without testing the prototype on actual asthmatics, the team was not able to gather any wheezing data. We were able to cough during testing to gather that data, but we could not make ourselves wheeze. Our intent was to use the first waveform chart from the low-pass filter to examine wheezing. The first chart shows the low frequency sounds during breathing. The team was hoping to get a normal, predictable low frequency signal in this range, but that is not the case. The signal is somewhat sporadic, which will make detecting changes at the level somewhat difficult. The team was able to pick up changes when the patient had deep inhalations or exhalations in this low frequency range. Although somewhat small, these changes were distinguishable from the normal breathing signal. Nevertheless, this data was not very useful since they looked similar to coughing signals in that range. In Figure [5] above, the coughing is very distinct on the waveform coming from the bandpass filter, but it also appears on the chart from the lowpass filter. Consequently, we would not be able to distinguish between a change in the depth of inhalation/exhalation and a cough in the 0 to 5 Hz range.

In addition, the team wanted to use the microphone data to detect changes in respiratory rate. We were not able to gather any data that indicated a change in respiratory rate. We hoped that we could use the low frequency data to find changes in respiratory rate. If the normal breathing function was a repetitive waveform, such as a sine wave, then the period of the signal could be used to detect changes in breathing rates. The 0-5 Hz signal from the low-pass filter produced an irregular, unpredictable output, so this process would not work. This type of procedure is better fit for spirometry testing, but the whole point of this project was to create a continuous, at home solution to detecting asthma. Spirometry tests are typically done by a doctor in a clinic or hospital. An alternative way for detecting changes in respiratory rate could be done using thermistor bands attached to the shirt. Dr. Mathur expressed interest in adding thermistor bands to the shirt in order to detect changes in lung volume and lung function. As the bands expand and contract, they change the resistance and therefore the output voltage. Using this data might be a better way of detecting breathing rate. The magnitudes of the output signals would be useful for determining lung volume/ function, but the period could be used to quantify changes in



respiratory rates. Since breathing rate is not a lung sound but rather a property of lung function, the thermistor bands might be better suited for this testing.

Although the group was able to detect useful data, there are still issues that need to be worked out. Right now, we are able to distinguish coughs from other signals and other noises. We could write code that could keep track of the number of coughs, when they occurred, the time between coughs, etc. This is all useful data, but there are not any thresholds that relate that data to asthma exacerbations. There is no set value that says so many coughs per minute signifies an asthma attack. We can continue to build upon the shirt and gather more and more data, but using that data to determine the onset of an asthma exacerbation will be very difficult. In addition, the false indication of an exacerbation is another concern. We want to make sure the patient is only notified if they are actually having an asthma attack. Otherwise, they might unnecessarily start their AAP. The device and corresponding algorithm will have to have a balance between being too careless and being too cautious. The former would cause the patient to be falsely notified while the latter would cause a delay in notifying them, allowing the asthma symptoms to worsen. The last aspect of this device that needs to be considered is patient confidentiality. We must ensure that the patient's data will remain private. Medical records and personal health information are protected under national HIPAA regulations, and this patient data must be treated the same way. If these regulations are not followed, there could be legal repercussions along with distrust for the product.

## Conclusions

The creation of an asthma shirt holds the potential to decrease the number of emergency services, hospital admissions, and doctor visits for those with severe asthma. Since the asthma symptoms felt by patients can be delayed for up to two days after the exacerbation has started, the patients are already experiencing decreased lung functions. By reducing the time between the start of an asthma exacerbation and starting the AAP, the level of inflammation and amount of lung function lost can also be reduced. This is especially important for severe asthma patients whose asthma exacerbations are more intense and harder to fight. In addition, it takes these patients longer to return to full lung function as well. Any time saved can greatly improve the quality of life for severe asthma patients. Distinguishing the different lung sounds was the first step in creating a functioning asthma shirt, and our device made great progress in successfully distinguishing coughs. Our device has shown a proof of concept that had not been shown before. We now have built a foundation that future design teams can build upon and continue to develop a continuous asthma monitoring device. The biggest limitation for this project was waiting for the DAQ. Although that delayed the project, we were still able to make considerable progress in the small amount of time we had left. If we received the device earlier in the semester, we may have developed the device even further. In the future we hope to perfect the thresholds for wheezing and coughing. From there, the application of multiple microphones, compression shirt, and resistor bands will allow for a more accurate diagnosis of the patient. Finally, we would creating a wireless shirt will allow for a true 24/7 continuous monitoring of asthma symptoms in severe asthmatic patients. Although there is still much work to be done, this semester has

produced a foundation for continuing to develop a continuous asthma monitoring device. There is no cure for asthma, and currently the only solution is treatment. This asthma shirt poses great potential to not only change the way asthma is treated but also to prevent asthma exacerbations altogether.

## References

- [1] American College of Allergy, Asthma, and Immunity (2014). *Asthma Information Overview* [Online]. Available: <http://acaai.org/asthma/about>
- [2] S Holgate and R Polosa MD. (2006, Aug 26). *The Mechanisms, Diagnosis, and Management of Severe Asthma in Adults* [Online]. Available: <http://www.sciencedirect.com/science/article/pii/S014067360669288X>
- [3] Weinstein, L. A. (1999, August 25). *U.S. Patent No. US6238353 B1*. Washington, DC: U.S. Patent and Trademark Office.
- [4] M. R. Miller, J. Hankinson, V. Brusasco, et. al. (2005, Aug). *Standardisation of Spirometry* [Online]. Available: <http://erj.ersjournals.com/content/26/2/319>
- [5] P. Bass. (2016, May 10). *What is Forced Expiratory Volume (FEV1)?* [Online]. Available: <https://www.verywell.com/forced-expiratory-volume-and-asthma-200994>
- [6] Simon, Harvey MD, Zieve, David MD, (Nov 2012). *Asthma in Adults*. Available: <http://umm.edu/health/medical/reports/articles/asthma-in-adults>
- [7] Kim, Harold, Mazza, Jorge, (Nov 2011). *Allergy, Asthma, and Clinical Immunology*. Available: <https://aacijournal.biomedcentral.com/articles/10.1186/1710-1492-7-S1-S2>
- [8] K Zimmermann (2016, March 11). *Respiratory System: Facts, Function and Diseases* [Online]. Available: <http://www.livescience.com/22616-respiratory-system.html>
- [9] Y. Koh, S. Chae and K. Min (1993, Aug). *Cough Variant Asthma is Associated with a Higher Wheezing Threshold than Classic Asthma* [Online]. Available: <http://onlinelibrary.wiley.com/doi/10.1111/j.1365-2222.1993.tb01796.x/full>

## Appendix 1



Figure [1] : Thermistor Mask

<http://justnebulizers.com/media/catalog/product/cache/15/image/a6711d7f987d93e940f67d503f6808af/R/-/R-MASK-003PCN-BI-01.jpg>

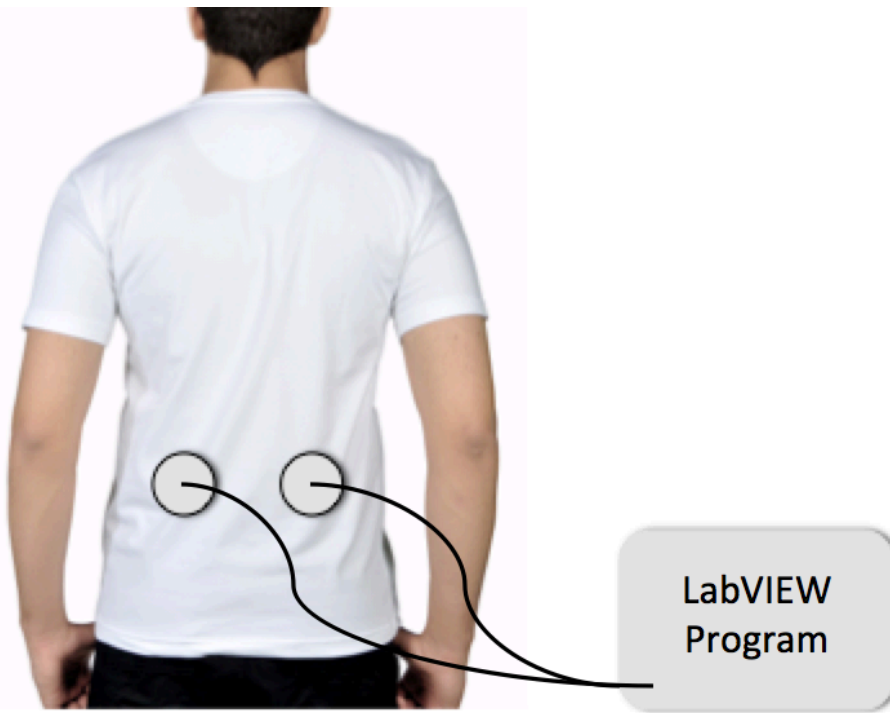

Figure [2] : Microphone and Electronic Stethoscope placement

## Appendix 2

### Continuous Monitoring of Asthma Control Product Design Specifications

**Client:** Dr Sameer Mathur

**Advisor:** Professor Willis Tompkins

**Team:** Tim Lieb [tlieb@wisc.edu](mailto:tlieb@wisc.edu) (Team Leader)  
Luke Le Clair [lleclair@wisc.edu](mailto:lleclair@wisc.edu) (Communicator)  
Luke DeZellar [ldezellar@wisc.edu](mailto:ldezellar@wisc.edu) (BSAC)  
Ryan Opansky [opansky@wisc.edu](mailto:opansky@wisc.edu) (BWIG)  
Roberto Romero [rromero4@wisc.edu](mailto:rromero4@wisc.edu) (BPAG)

#### Function:

The function of our product will be to continuously monitor asthma patients. In severe asthma patients (the top 10%), the asthma symptoms are often more frequent and more extreme. This small group accounts for a large portion of health-care costs, hospital admissions, doctor visits (both scheduled and unscheduled), and emergency services. In addition, the frequent symptoms and long recovery times can lead to a “chronic wound” with the ongoing epithelial tissue damage and repair. Oftentimes, patients who undergo asthma exacerbations do not notice the symptoms for up to two days after they have started. The goal of our project is to detect the onset of an asthma exacerbation earlier in order to try and prevent the asthma attack

rather than just treat it. Our product will be able to detect changes in lung sounds and alert the patient to start their asthma action plan (AAP). We will make our own electronic stethoscope using a stethoscope head along with an audio microphone to listen to the lung sounds. The three main symptoms we will try to detect are coughing, wheezing, and respiratory rate.

#### **Client requirements:**

- The client does not want use to try and tackle the entire “asthma shirt” but rather start on just part of it
- The first focus of the project is to design a device to monitor lung sounds (breathing, coughing, wheezing, etc.)
- The client suggested using a stethoscope inspired microphone system to capture the sounds, but the team will explore other options as well.
- A data acquisition device will be used along with the device in order to get the data into the labview program
- There are not any “thresholds” or previously determined measurements for this type of data, so we will have to try and figure those out on our own
- The primary focus for this semester is not to necessarily have a complete, finished product by the end, but rather get preliminary data that can be built upon

#### **Physical and Operational Characteristics:**

*a. Performance requirements:* The device must be able to collect data for a minimum of 4 hours to start. Eventually, the device should be able to run 24/7. It should be able to continuously monitor asthma, although it might not necessarily be worn all the time. At this point, it will be powered by a physical 3.3 V hookup, but in the end, the device will be run wirelessly and be powered with batteries. When integrated into a shirt, the microphones must be able to be removed in order to wash the shirt.

*b. Safety:* Safety is not huge concern with this device because there is very low potential for danger. The part of the device that is in contact with the patient is the stethoscope head, which does not pose any danger. The connections between the microphone, the cable and the DAQ must be properly encased/ taped to prevent any electrocution/ short circuiting. The only other safety concern is making sure the device does not falsely detect an asthma exacerbation, but determining thresholds for this will come later in the project.

*c. Accuracy and Reliability:* The microphone must accurately and precisely detect sound differences in asthma symptoms such as wheezing and coughing. The device must be able to distinguish these from talking, movement, ambient noise, etc. This will mostly be done using various filters. The group would also like to detect changes in respiratory rate. This will require looking at the changes in the signals rather than just values at an instant in time.

*d. Life in Service:* Due to the fact that this is continuous monitoring of asthma symptoms, there will be no limit on the microphones life in service. It will only end if there is another technology that is more effective than this microphone. The batteries will be the only part of the device that will need regular replacement. The target goal is 12 hours of battery life during use so the patient can go all day without needing to replace the batteries.

*e. Shelf Life:* This is not a major concern for this project. The only aspect of the device that would be affected by shelf like are the batteries, but they will be able to be replaced

easily. The product should be able to work no matter how old it is, but the older it gets, the more technology advances. If the product is too old, its technology will probably become outdated.

*f. Operating Environment:* One operating environment concern is that the electrical components will need to stay dry. The stethoscope head is not affected by moisture, so any perspiration will not damage the device. The device ideally will not be used at extremely hot or extremely cold temperatures because it could affect the electrical components. In addition, if the operating environment is very noisy, it will be difficult to gather good, reliable data.

*G. Ergonomics:* The device should be able to fit into many different shirt sizes so it can be adaptable to individuals of all sizes. The device will go against the skin of the patient on the lower back, so it should be as comfortable as possible.

*H. Size:* The size of the device does not matter a lot for this semester. Ideally, the device will be as small as possible so that the patient hardly notices they are wearing it. The stethoscope head diameter is not a huge concern, but the thickness will greatly affect patient comfort.

*I. Weight:* The main concern is that the patient will be able to wear the shirt. This means that the product will need to be light enough to wear without much discomfort/ without causing the shirt to sag down. This becomes a larger concern when making the device wireless and adding batteries.

*J. Materials:* The stethoscope is made for contact with the skin, so the material of that is not an issue. If in the future we create our own stethoscope head/ microphone casing, then the material must be one that does not irritate the skin (most likely a plastic).

*K. Aesthetics, Appearance, and Finish:* The primary goal for this semester is functionality. When the device is integrated into a shirt, we want the shirt to appear as normal as possible. This is another reason why we want the device to be as small/ lightweight as possible. The color, texture, design, shape etc of the shirt will be variable parameters that can be determined by each individual.

## **Production Characteristics**

*a. Quantity:* Right now, we are only developing one microphone. Eventually, the shirt will incorporate 2 microphones, one for each lung. Each patient should only need one of these devices, but they may have various shirts to use with it.

*b. Target Product Cost:* Currently, there are no similar products like the one we are working on in which to compare the expected cost. The previous design team was able to develop a similar shirt for just under \$300. Our budget is \$300 for this semester, but can be expanded with approval from our advisor. Many of the components for the device are rather inexpensive except for the DAQ. Ideally, this product would be inexpensive enough so that as many asthma patients that need it can afford to buy one.

## **Miscellaneous**

*a. Standards and Specifications:* As of now this product will not need FDA approval but if it is implemented in the future for diagnosis it will. In order to test this on asthma patients, we need an IRB protocol. Dr. Mathur has a protocol pre-approved that we can use. The group members must follow all the HIPAA regulations regarding patient data.

*b. Customer:* Since there is no such product on the market, there really is not any customer likes, dislikes, preferences, etc. The customer will have to wear this shirt, so they probably want the shirt to be as comfortable as possible. A good target for this is trying to make this shirt feel as close to wearing a normal shirt as possible.

c. *Patient-related concerns:* If the microphone in the shirt cannot filter out outside noises, the patient may worry about the reliability of the product. The device should only notify the patient when they are actually having an asthma exacerbation. False alerts could be a major issue, especially if the individuals AAP include taking medications. Also, the patient information must remain safe and confidential. That way they won't be worried about invasion of personal privacy.

d. *Competition:* As of now there are no similar items that exist. The devices that are used to detect asthma are not at for at home use and they are not continuous. There are various wearable technologies on the market, like fitbits and hexoskin shirts, but those have nothing to do with asthma.

## Appendix 3

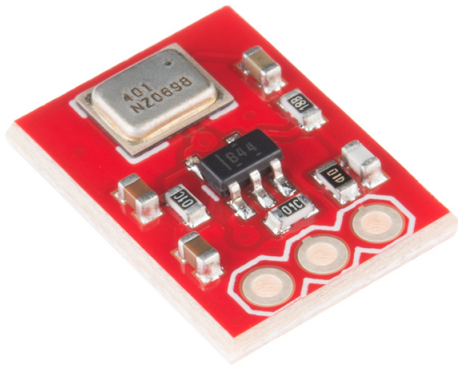

Figure [1]: Sparkfun MEMS Microphone Breakout-INMP401



Figure [2]: Shielded Cable



Figure [3]: 3M Littmann lightweight Stethoscope



Figure [4]: Arduino Microcontroller





Figure [5]: National Instruments USB-6002 Data Acquisition device

Company	Item	Price	Quantity	Total including shipping	Used
Amazon	3M Littmann Lightweight II S.E. Stethoscope, black tube, 28 inches	\$44.89	1	\$51.57	Yes
Amazon	Everdixie USA dual head stethoscope	\$5.95	1	\$5.95	No
National Instrument	USB-6002 Data Acquisition	\$329.00	1	\$346.63	Yes
Sparkfun	MEMS Microphone Breakout-INMP401	\$8.96	3	\$34.94	1
Sparkfun	Mono Audio Amp Breakout - TPA2005D1	\$7.95	1	\$19.15	No
	Shielded cable with two conductors	Free	1	Scrap from lab	Yes
	Rubber bulb from a blood pressure cuff	Free	1	Scrap from lab	Yes
Total:				\$458.24	

# Appendix 4

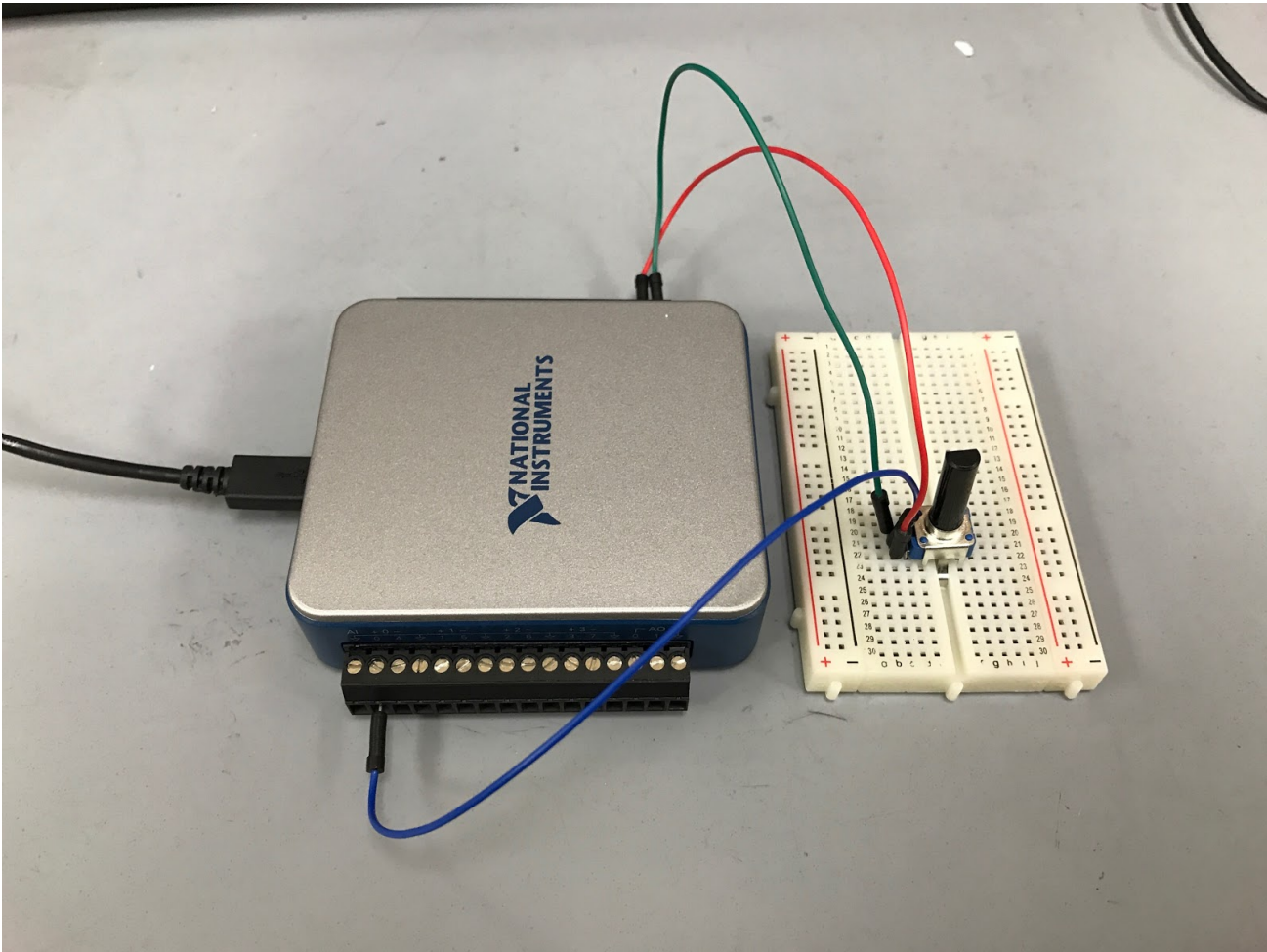

Figure [1]: Setup for DAQ testing using a potentiometer

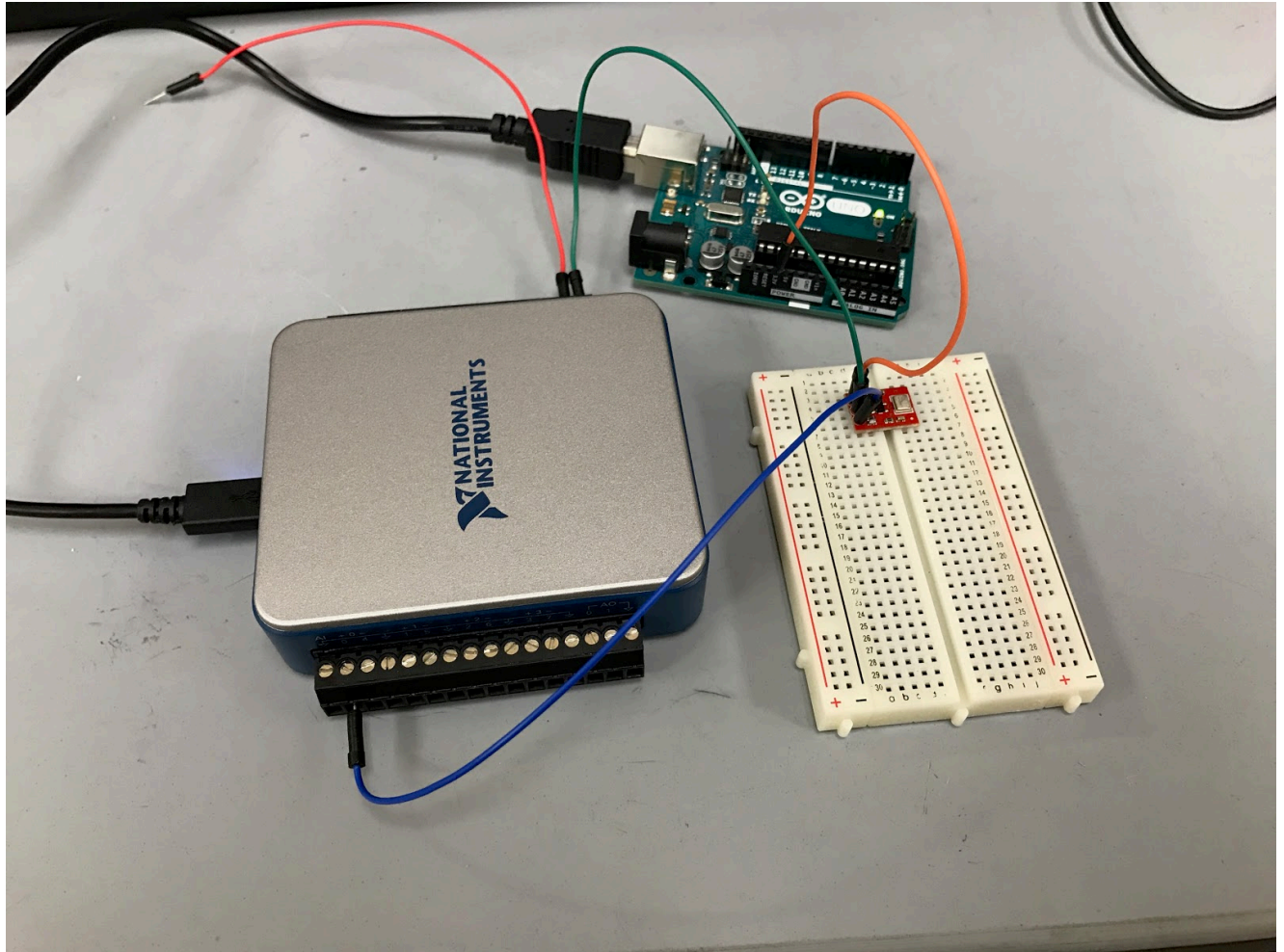

Figure [2]: Setup for DAQ testing using the microphone

# Appendix 5

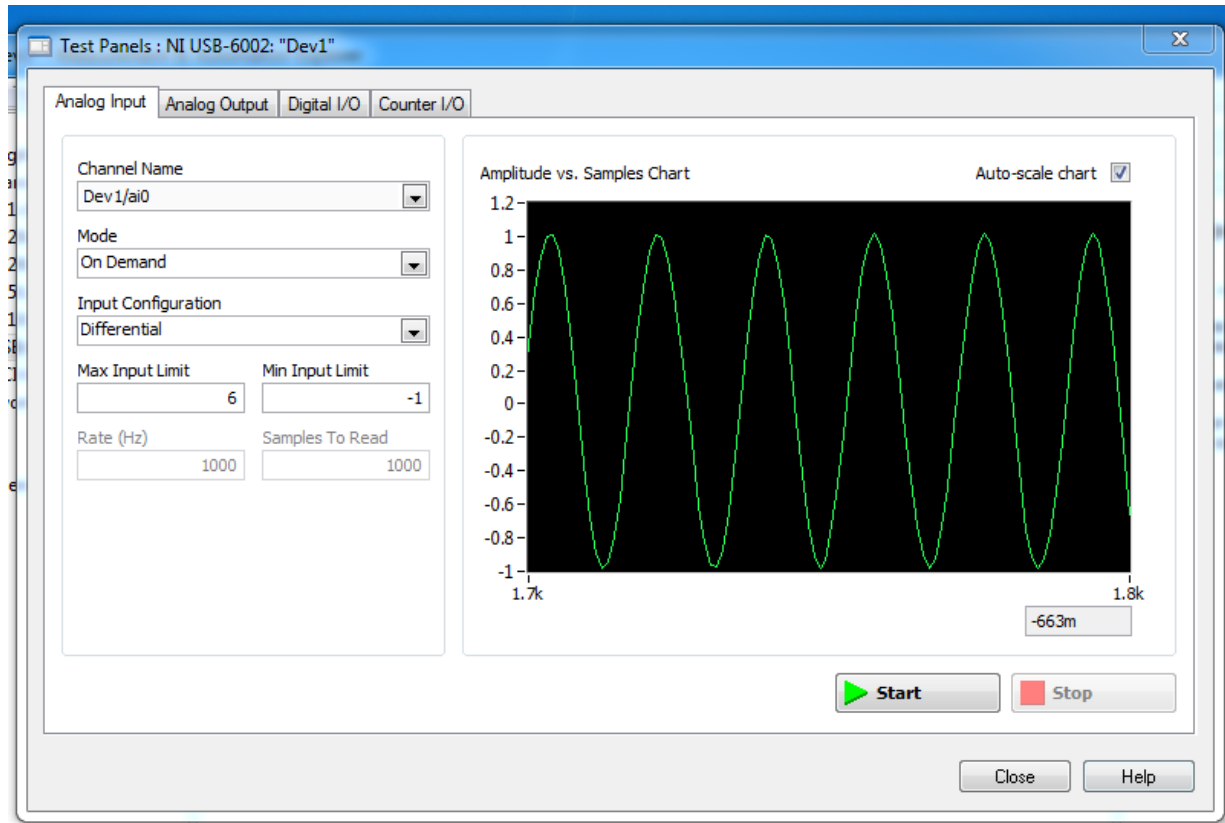

Figure [1]: DAQ testing using the Test Panel- sine wave

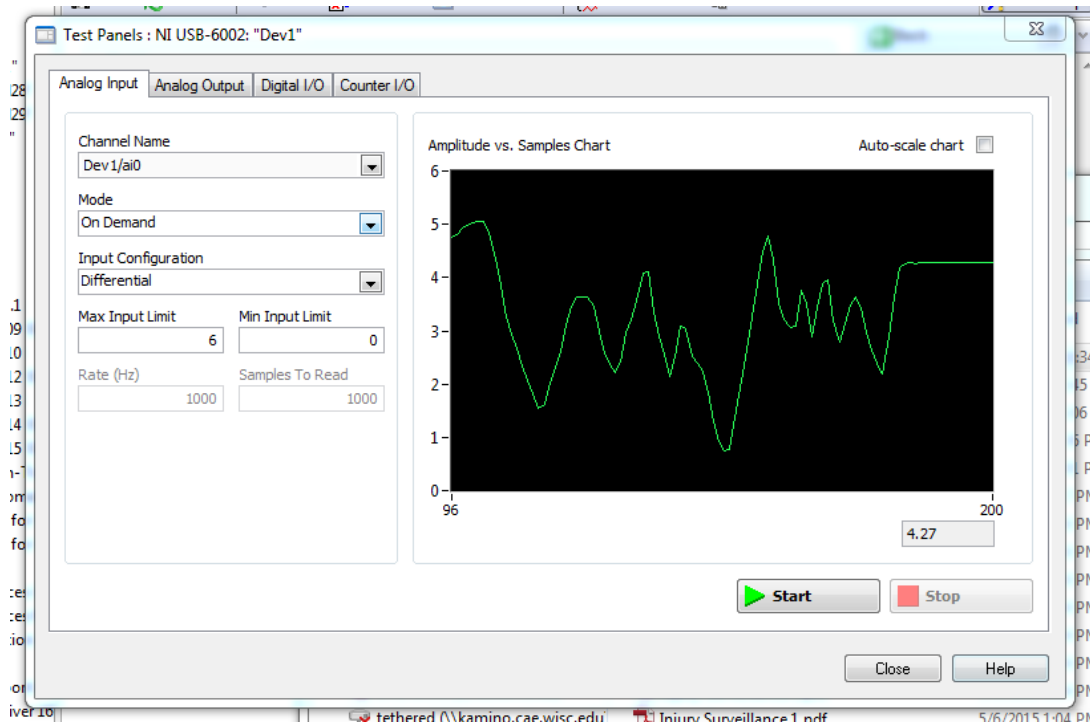

Figure [2]: DAQ testing using the Test Panel- potentiometer

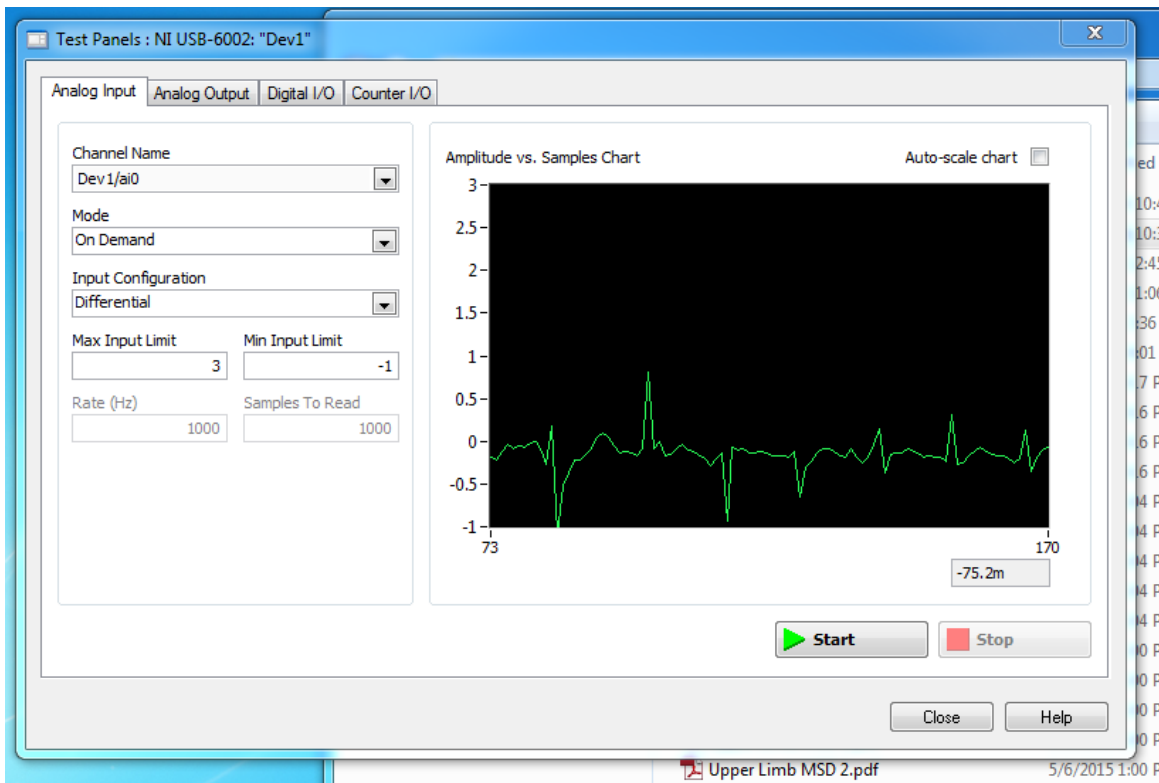

Figure [3]: DAQ testing using the Test Panel- microphone with finger snapping



# Appendix 6

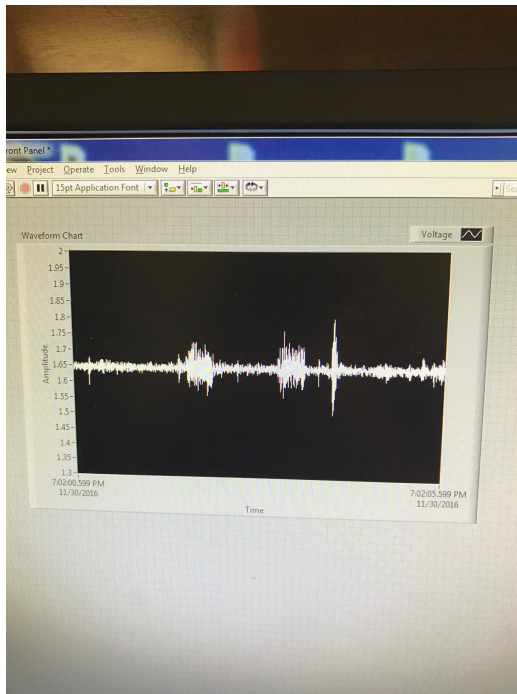

Figure [1]: Raw data- talking

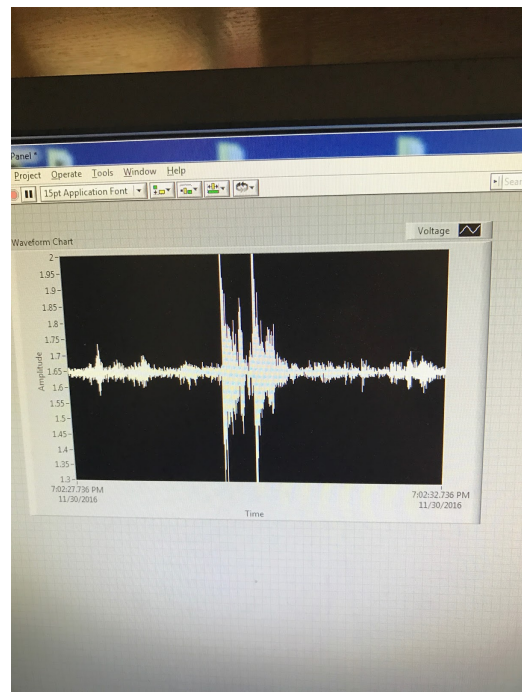

Figure [2]: Raw data- coughing

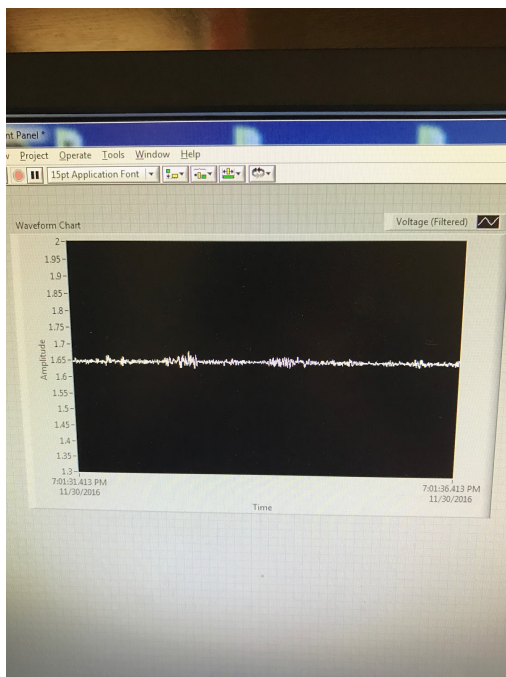

Figure [3]: Filtered data- talking

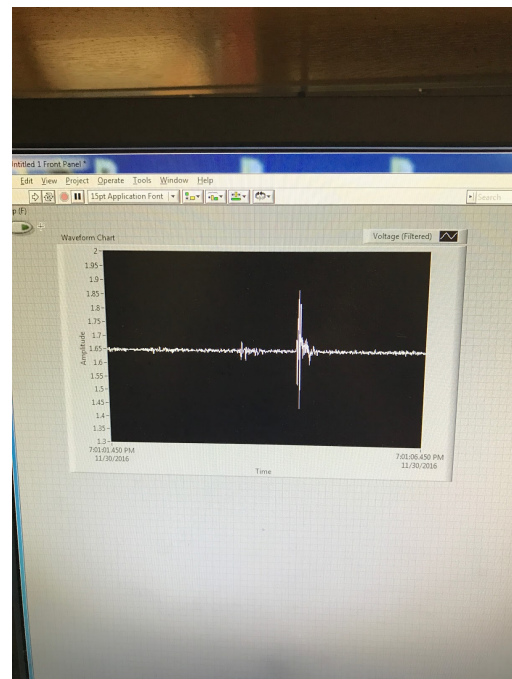

Figure [4]: Filtered data- coughing

# Appendix 7

## Asthma Action Plan

For: \_\_\_\_\_ Doctor: \_\_\_\_\_ Date: \_\_\_\_\_  
 Doctor's Phone Number: \_\_\_\_\_ Hospital/Emergency Department Phone Number: \_\_\_\_\_

### Doing Well

- No cough, wheeze, chest tightness, or shortness of breath during the day or night
- Can do usual activities

And, if a peak flow meter is used,

Peak flow: more than \_\_\_\_\_ (80 percent or more of my best peak flow)

My best peak flow is: \_\_\_\_\_

Before exercise

\_\_\_\_\_  2 or  4 puffs \_\_\_\_\_ 5 minutes before exercise

Take these long-term control medicines each day (include an anti-inflammatory).  
 Medicine How much to take When to take it

### Asthma Is Getting Worse

- Cough, wheeze, chest tightness, or shortness of breath, or
- Waking at night due to asthma, or
- Can do some, but not all, usual activities

-Or-

Peak flow: \_\_\_\_\_ to \_\_\_\_\_ (50 to 79 percent of my best peak flow)

**Fast** Add: quick-relief medicine—and keep taking your GREEN ZONE medicine.

\_\_\_\_\_ (if using dry-powder)  2 or  4 puffs, every 20 minutes for up to 1 hour  
 Nebulizer, once

**Slow** If your symptoms (and peak flow, if used) return to GREEN ZONE after 1 hour of above treatment

Continue monitoring to be sure you stay in the green zone.

-Or-

**Fast** If your symptoms (and peak flow, if used) do not return to GREEN ZONE after 1 hour of above treatment:

Take: \_\_\_\_\_  2 or  4 puffs or  Nebulizer

Add: \_\_\_\_\_ (oral steroid) \_\_\_\_\_ mg per day For \_\_\_\_\_ (3–10) days

Call the doctor  before/  within \_\_\_\_\_ hours after using the oral steroid.

### Medical Alert!

- Very short of breath, or
- Quick-relief medicines have not helped, or
- Cannot do usual activities, or
- Symptoms are severe or get worse after 24 hours in Yellow Zone

-Or-

Peak flow: less than \_\_\_\_\_ (50 percent of my best peak flow)

Take this medicine:

\_\_\_\_\_ (if using dry-powder)  4 or  6 puffs or  Nebulizer

\_\_\_\_\_ (oral steroid) \_\_\_\_\_ mg

**Then call your doctor NOW.** Go to the hospital or call an ambulance if:

- You are still in the red zone after 15 minutes AND
- You have not reached your doctor.

### ANGER SIGNS

- Trouble walking and talking due to shortness of breath
- Lips or fingernails are blue

**Take**  4 or  6 puffs of your quick-relief medicine AND  
 **Go to the hospital or call for an ambulance** \_\_\_\_\_ NOW!

See the reverse side for things you can do to avoid your asthma triggers.