BME 400: Microscope Cell Culture Incubator

Team Members: Trevor Zarecki, Jenny Westlund, Peter
Hartig, Jack McGinnity, Steven Gock

Advisor: Dr. Mitchell Tyler
Client: Dr. John Puccinelli

Overview

- Problem Statement
- Background
- Design Requirements
- Design Ideas and Matrix
- Future Work

Problem Statement

The client desires an inexpensive incubation chamber for use in live cell imaging on an inverted microscope. The incubator should regulate temperature, CO₂, and humidity levels in the chamber with minimal gradients. The device should also be accessible for changing media and available for use with different types of cell culture dishes.

Key Elements of Successful Cell Culture

- Sterility
- Physiological Temperature and Humidity
 - Temperature Uniformity
- System buffer for pH of growth media

Why Scope Integrated Incubation?

1. Continuous image collection
2. Reduced environmental interference
3. Higher imaging location consistency
4. Ease of data collection

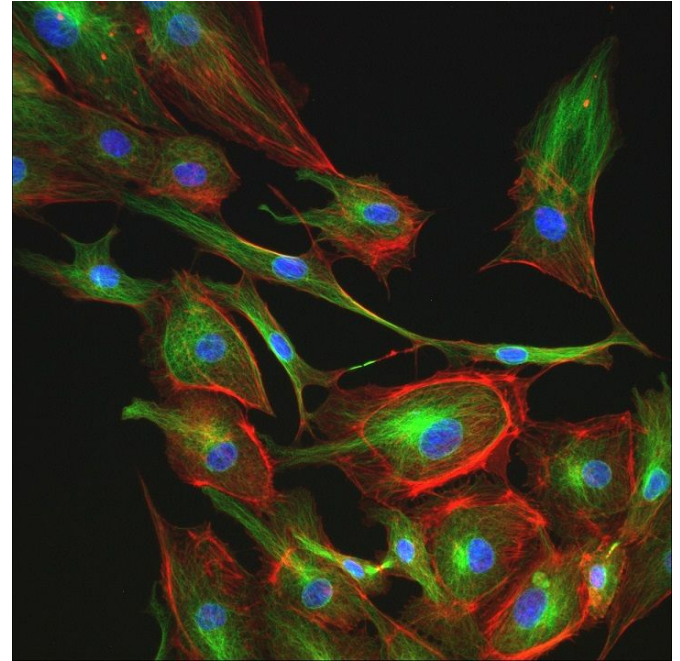

Current Market

High-end, scope integrated systems

- High cost ~ \$10,000 -- \$30,000
- Static system
- Error-prone

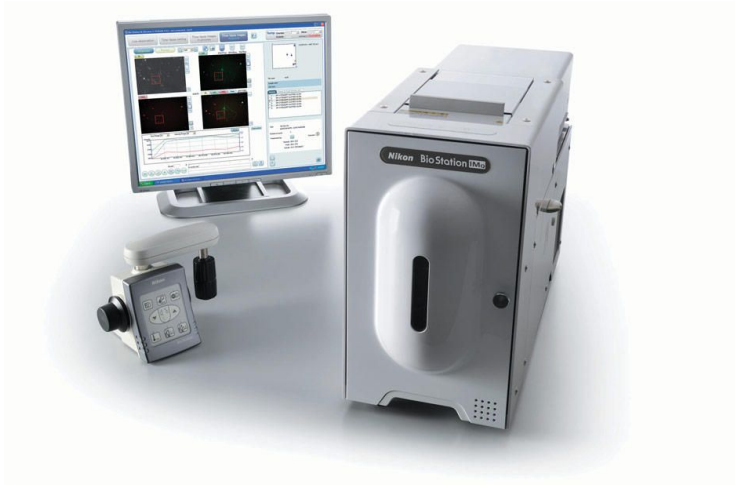

Small-scale/Homemade stage incubators

- Large temperature and humidity gradients
- Lacks features of standard incubator
- High relative cost ~ \$600

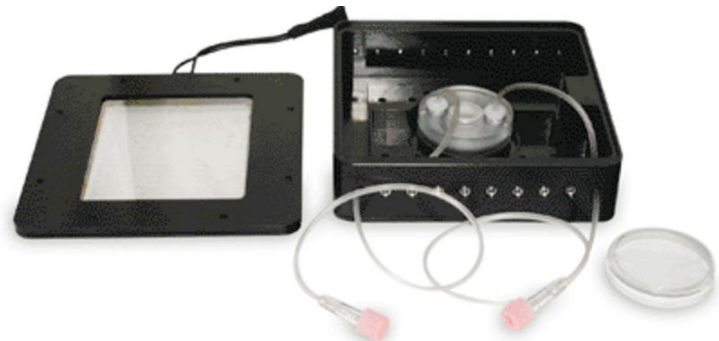

Design Specifications

- Environmental Controls
 - Temperature -- $37\text{ }^{\circ}\text{C} \pm 1^{\circ}\text{C}$
 - Humidity -- $95\% \text{ RH} \pm 5\%$
 - CO_2 -- $5\% \pm 1\%$
- Optical Compatibility
 - Bright field and fluorescent imaging
- Monitor cells for up to 2 weeks
- Compatible with Multiple Microscopes
 - Can move from stage to stage
- Low-cost
 - \$200 budget, \$500 target price

Design Components

- Heating Elements
 - Heating pad, heat exchanger, sensor
- Humidifier
 - Water atomizer, RH sensor
- CO₂ Control
 - CO₂ tank, valve, sensor
- Imaging-compatible material
 - Plexiglass
- Microcontroller and circuitry
 - Arduino Mega

Design 1: Basic Box

- Advantages
 - CO₂ Regulation
 - Ease of Design
- Disadvantages
 - Heat Regulation
 - Humidity

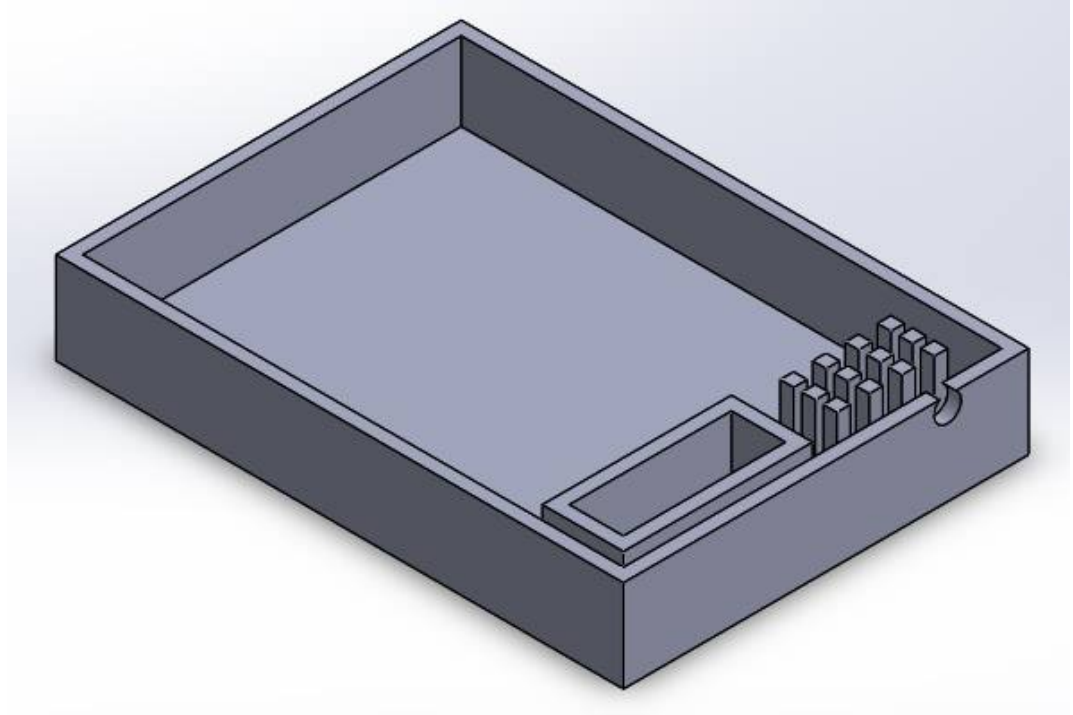

Design 2: Dual Chambers

- Advantages
 - Humidity
 - Ease of prototype development
- Disadvantages
 - CO₂ Regulation
 - Complexity

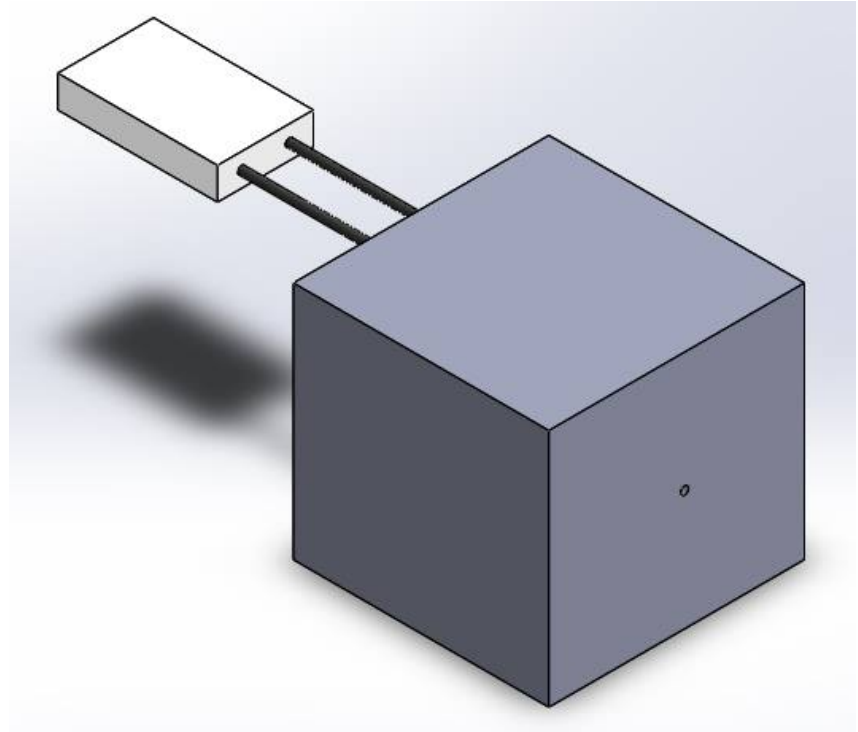

Design 3: The Moat

- Advantages
 - Heat Regulation
 - CO2 Regulation
- Disadvantages
 - Humidity
 - Complexity

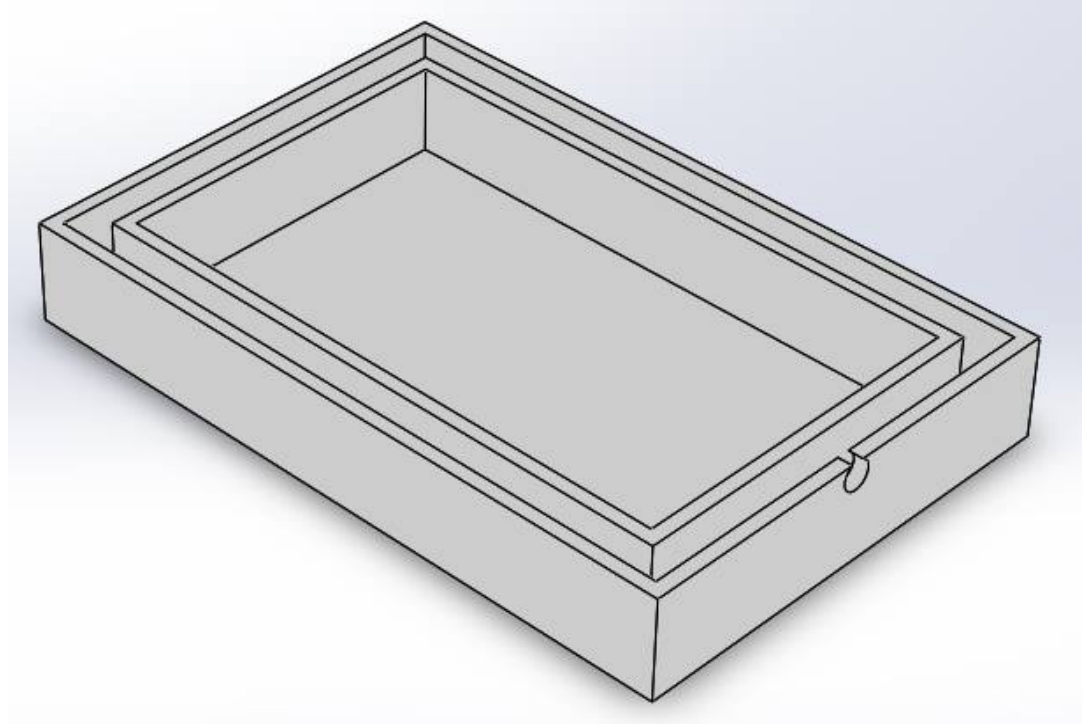

Design Matrix

Criteria	Weight	Design 1: Basic Box		Design 2: Dual Chambers		Design 3: The Moat	
Heat Regulation	25	2/5	10	3/5	15	4/5	20
CO2 Regulation	20	4/5	16	3/5	12	4/5	16
Humidity	20	2/5	8	4/5	16	3/5	12
Ease of fabrication	15	4/5	12	3/5	9	2/5	6
Cost	10	4/5	8	3/5	6	3/5	6
Accessibility	5	4/5	4	3/5	3	1/5	1
Safety	5	4/5	4	4/5	4	3/5	3
Total	100	62		65		64	

Future Work

- Develop Prototype
 - Design hardware/software for CO₂, RH, and temperature monitoring/regulation independent of one another
 - Integrate components into one circuit and one script
- Testing
 - Use enclosure to validate sensors
 - Validate imaging compatibility of plexiglass
- Continue Fabrication
 - Create separate housings for stage and hardware
 - Connect chambers and test system on larger time scale
- Beyond this semester:
 - Large scale/professional production
 - Test with cells

Acknowledgements

Client: Dr. Puccinelli

Advisor: Dr. Mitch Tyler

References

Image Citations

- <https://www.nikoninstruments.com/Products/Live-Cell-Screening-Systems/BioStation-IM-Q/Gallery>
- <http://www.etaluma.com/products/about-lumascope-fluorescent-microscopes/>
- http://www.biosciencetools.com/catalog/Incubator_Motorized.htm