

16 December 2016

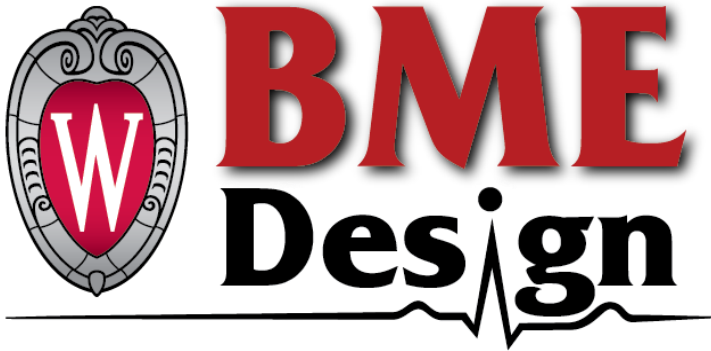

**Universal Exercise Unit - Spider Cage**

BME 400 Design, Fall 2016

**Leader.....Kevin Collins<sup>a</sup>**  
**BSAC.....Sheetal Gowda<sup>b</sup>**  
**BPAG.....Stephen Kindem<sup>a</sup>**  
**BWIG.....Breanna Hagerty<sup>b</sup>**  
**Communicator.....Darcy Davis<sup>a</sup>**

**Client.....Matt Jahnke<sup>e</sup>**  
**Advisor.....Joseph Towles<sup>b</sup>**

<sup>a</sup>Department of Mechanical Engineering, University of Wisconsin-Madison, WI 53706

<sup>b</sup>Department of Biomedical Engineering, University of Wisconsin-Madison, WI 53706

<sup>c</sup>United Cerebral Palsy - 2801 Coho St. #300 Madison, WI 53713

## **Abstract**

Cerebral palsy is a group of non-progressive, non-contagious motor conditions caused by a delay in physical development. The disease is usually acquired prenatally and caused by abnormal brain development in regions associated with movement such as the motor cortex and pyramidal tracts. There is no cure for cerebral palsy but treatment options include surgery, medication, and therapy. Matt Jahnke is the adult program director for United Cerebral Palsy (UCP) of Greater Dane County and he has tasked the team with creating a spider cage to aid in physical therapy. Spider cages are structures used in physical therapy to help motor impaired individuals gain strength, muscle control, balance, and independence. The team fabricated a spider cage out of 80/20 Inc. aluminum based on a panels design that contains a wire-mesh caging for harness attachment points. Coinciding with fabrication, deflection simulations were completed to determine the soundness of the overall structure and adjustments were made to the design as needed. Due to time limitations, full scale testing will be conducted next semester. Once fabricated and tested, UCP will be able to use the spider cage for therapy needs within its facility.

## Table of Contents

Abstract.....	2
1.0 Introduction.....	4
1.1 Client.....	4
1.2 Problem Statement.....	4
1.3 Background.....	4
1.4 Project Motivation.....	5
2.0 Preliminary Designs.....	5
2.1 Panels Design.....	6
2.2 Telescoping Design.....	7
2.3 Foldable Design.....	8
2.4 Evaluation of Preliminary Designs.....	9
2.5 Material Change and Proposed Final Design.....	11
3.0 Fabrication.....	12
3.1 Materials.....	12
3.2 Assembly.....	13
4.0 Testing.....	13
4.1 Mesh Deflection.....	13
4.2 Beam Deflection.....	14
5.0 Results.....	15
5.1 Mesh Deflection.....	15
5.2 Beam Deflection.....	17
6.0 Discussion.....	17
7.0 Conclusion.....	17
8.0 Acknowledgements.....	18
References.....	18
Appendix.....	19
A. PDS.....	19
B. Materials List.....	23
C. Assembly Process.....	24
D. Testing Procedure.....	25
E. Beam Deflection Calculation.....	26
F. Mesh Deflection Table.....	27
G. Gantt Chart.....	28

## 1.0 Introduction

### 1.1 Client

Matt Jahnke is the adult program director for United Cerebral Palsy (UCP) of Greater Dane County. UCP provides supportive services for individuals with physical disabilities such as autism, Down syndrome, epilepsy, and cerebral palsy [1]. Engineering students at the University of Wisconsin-Madison have worked on multiple projects for UCP over the past years to create adaptive equipment for the facility. In the fall of 2014 and spring of 2015, a biomedical engineering team worked with the client, Mr. Jahnke, to create a spider cage for therapy uses. The design was electronically modeled but never fabricated. Mr. Jahnke would like the spider cage to be redesigned and fabricated.

### 1.2 Problem Statement

A spider cage is a structure used by therapists to help treat muscular conditions and is typically used to treat children with cerebral palsy. The cage functions by resisting the patient's movements with the use of resistance bands connected to both the frame of the cage and a customized suit worn by the patient. The resistance to movement or displacement of weights allows for the development of gross motor movements and coordination skills. Spider cages are commercially available but can cost over \$4,000 [2]. The client is looking for a design that is relatively inexpensive, uses previously purchased material, transportable via flatbed truck, able to fit through a doorway with dimensions of 82" by 42.5", and able to be assembled by employees of UCP.

### 1.3 Background

Cerebral palsy currently affects 17 million people worldwide [3] and 764,000 of those individuals are from the United States [4]. The incidence of cerebral palsy in children is 3.1 in 1000 across the United States, and 2.6 in 1000 in Wisconsin [5]. Different therapies and treatment techniques are being developed every day to aid those with the disability and ultimately allow them to become more independent.

Cerebral palsy is a group of non-progressive, non-contagious motor conditions caused by a delay in physical development. Almost 80% of cases are acquired prenatally and arise from abnormal brain development of the fetus. Premature and low birth weight babies are most at risk for developing cerebral palsy and the disease affects 0.2 - 0.35% of all live births [6]. Perinatal and postnatal causes each account for 10% of cerebral palsy cases and are caused by infection and head trauma [7]. The disorder affects each individual differently and can cause complications in one limb, two limbs, or even the whole body. The two most common forms of cerebral palsy are ataxia, which is defined as a lack of motor control with voluntary movements, and spasticity, which is categorized as stiff or tight muscles and exaggerated reflexes [8]. Aside from interfering with physical movement of the body, cerebral palsy can also cause disturbances in sensation, perception, communication, and behavior. Currently there is no cure for the disorder but there are treatments options to help make the lives of those affected as independent and manageable as possible.

Forms of treatment for cerebral palsy include surgery, medication, and therapy. Surgery can be performed to release tight muscles and to correct anatomical abnormalities, leading to reduced pain. Medications are taken to control spasticity, seizures, and to also reduce pain. Physical therapy is another, less invasive, treatment option. The goal of therapy is to help

individuals gain bodily function by helping them learn to control gross motor functions. Therapy equipment includes, but is not limited to, resistant bands, orthotics, and an exercise unit called a spider cage [8].

#### *1.4 Project Motivation*

The notion of spider cage therapy was first introduced in Poland by Norman Lozinski in 1994. The therapy is set up by attaching a set of elastic cords to a customized suit worn by the patient as well as attaching the cords to the cage of the structure (Figure 1). The cords may have varying stiffness depending on the needs of the patient and the specific exercises performed. The goal of spider cage therapy is to help patients improve balance, gain muscle strength, and develop coordination [9]. Ideally, the therapy will help the patient learn/build skills to perform daily tasks and thus gain independence.



**Figure 1.** This patient is receiving therapy in the spider cage via an elastic cord and harness system [10]

UCP does not currently have a spider cage therapy unit within its facility but adding this structure would be beneficial to cerebral palsy treatment efforts. While commercially available spider cages are functional and provide a range of benefits, they are expensive and difficult to transport. Fabricating a relatively inexpensive and portable model that has the same level of functionality as a commercial model is desirable to UCP and could be beneficial to many other treatment centers as well. With a lower cost, more facilities would be able to afford spider cages and then this form of therapy could be utilized by more children worldwide.

## **2.0 Preliminary Designs**

Each preliminary design was created with the use of Telespar tubing. This material was already purchased by the previous design team and will likely be used in the fabrication of the cage.

## 2.1 Panels Design

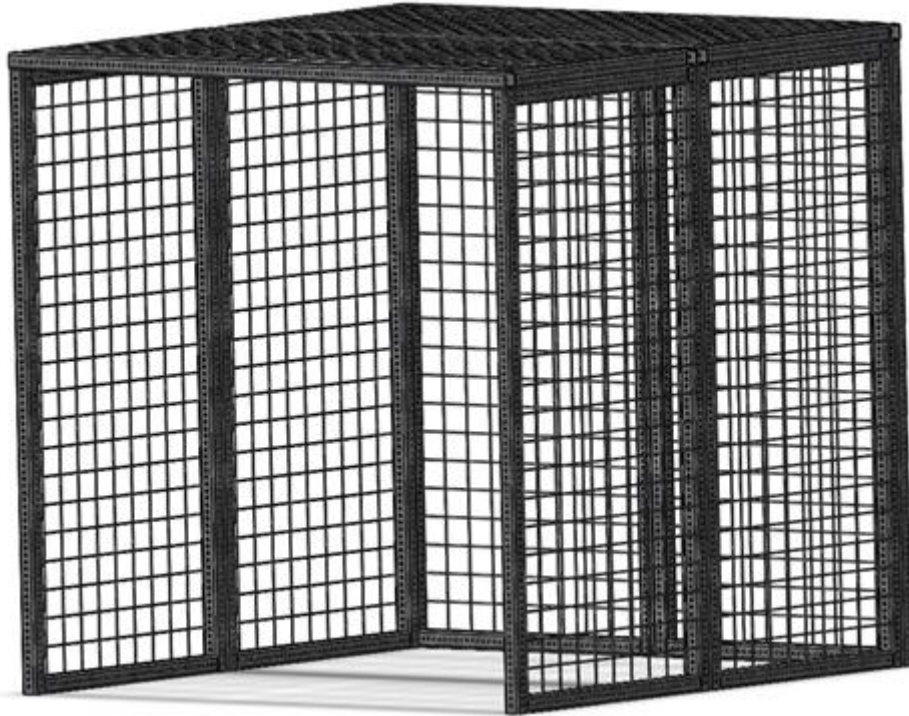

**Figure 2.** This CAD image shows the preliminary model of the panels design.

Modular panels are the focus of the first design. The design utilizes two rectangular panels on each of the sides and the top of the spider cage for a total of eight panels (Figure 2). Each of the panels are similar in size and configuration; each one would be about 3.5' wide and about 7' tall. Individual panels would have four framing members: two vertical and two horizontal members on the sides and top/bottom, respectively. The framing members would be either welded together or bracketed. Steel mesh with 3-4 square inch openings would be attached to the framing members to assist with lateral stabilization and for resistance band connections. The mesh would likely be welded to the framing members to eliminate the need for additional connection material that would add unnecessary weight relative to only welding. Welding individual sections of mesh to each panel's frame members is fairly practical for this design since each panel can be removed from the structure for repair or maintenance. The side and back panels would connect to one another with about 3-4 bolts spread out evenly between the top and bottom of the panels.

The panels design has various benefits as well as drawbacks. Benefits of the panels design include: easy fabrication, few pinch points, low section weight, and easy repair. Since the design is made of eight panels, stabilizing the panels during the bracketing/welding portion of the fabrication process would be relatively easy. Also, there are no complicated mechanisms or intricate components with tight tolerances which helps reduce the possibility of fabrication error. Since the panels are not dynamic and have no folding/telescoping elements, there are few pinch points in the design. The design's use of eight panels helps distribute the total weight of the spider cage when disassembled and allows each panel to be repaired individually if

necessary. The drawbacks of the panels design are that it may be cumbersome to assemble the sides and top and that there are many sections. Multiple people would be needed to hold and align the panels when bolting them together. Once the sides of the panel are connected together, the assemblers would need to lift and position the sections onto the top of the sides and back section.

## 2.2 Telescoping Design

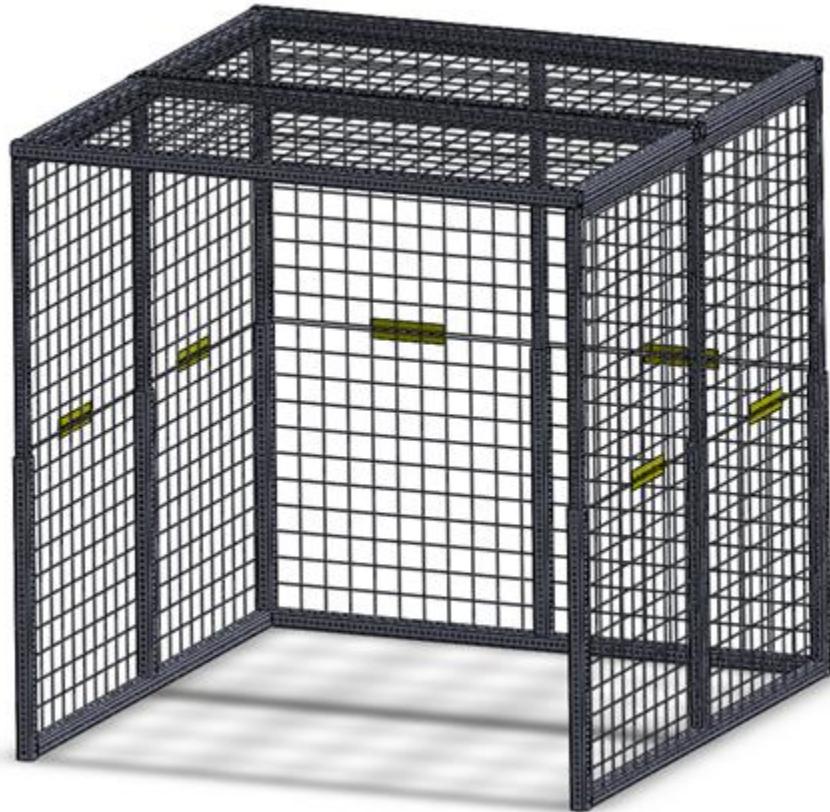

**Figure 3.** Three-dimensional model of the telescoping design. The hinges are colored yellow on the model.

The general concept of the next design is to utilize the Telespar's ability to telescope within one another in order to reduce the size of the cage sections. This telescoping design has a total of five modular sections; one for each of the sides and back of the cage and two for the top. The two sections on the top of the cage would be almost identical to the sections described in the panels design. Each section would be about 3.5' wide by about 7' long and the sections would have a total of four framing members; two vertical and two horizontal members on the sides and top/bottom, respectively. They would also utilize the same mesh configuration as the panels design. The telescoping design differs in the design of the side and back sections. The side sections would be about 7' x 7' when extended and about 3.5' tall and 7' wide when collapsed. They would be comprised of a horizontal member on both the top and bottom of the sections and three telescoping vertical members with one on each edge and the middle of the section. The design would also use the same wire mesh mentioned in the panels design for all

sections. The wire mesh on the bottom half of the sections would be welded on, but the mesh on the top half does not use the same configuration. The top half of the mesh would be hinged onto the lower half so that it can be folded down allowing the frame members to telescope. The top portion of the mesh would be attached to the frame by plates/bolts when the section is in its extended state. The back section of the design is very similar to the side sections, with the exception that there is only one vertical member placed in the middle of the section.

The telescoping design has multiple benefits as well as drawbacks. Benefits to this design are fewer sections and that the top and sides are relatively easy to assemble. Since there are only five sections in total, the telescoping design has more components of the cage consolidated together resulting in fewer sections to manage. Assembling the top of the cage is safer and more practical with this design since the top can be assembled at a height of around 3.5' then raised instead of being assembled at the full height of 7'. Drawbacks of the telescoping design are: high section weight, pinch points, reparability, and ease of fabrication. Although the telescoping design would have a lower total weight compared to the other designs, it has fewer sections so the weight of each section would be higher. High section weight may make it more difficult for the assemblers during transportation. The dynamic sections that would be used in the design inherently add pinch points due to the telescoping and folding elements. Pinch points are potential sources of injury and would all need to be addressed in the final design to ensure the safety of assemblers. Having only five sections in the design may make it more difficult to repair an individual section due to their size. The dynamic elements of the design increase the potential for maintenance or repair while also adding complications to the fabrication process.

### *2.3 Foldable Design*

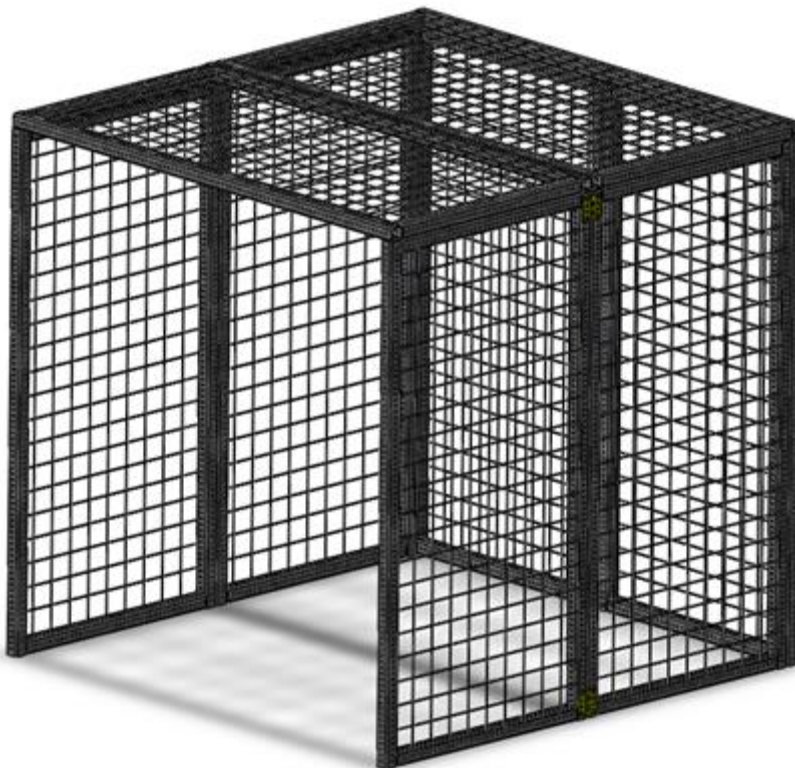



**Figure 4.** Three-dimensional model of the foldable design. The hinges are colored yellow and are on the top and bottom of the side sections.

The foldable design is very similar to the panels design with the exception that the two panels on each of the sides and back are hinged together. The panels that comprise each section would be the same as those used in the panels design, yet they would be hinged together instead of bolted; resulting in a total of five sections (the panels used for the top section would not be hinged together to simplify the assembly of the top). The hinges would allow the sections to fold along a vertical axis to reduce the size of the sections during transportation.

Like the other two designs, the panels design has various benefits as well as drawbacks. Some of the design's benefits include ease of fabrication and the relatively few number of sections used. Since each of the sections is comprised of at most two panels, it would be easy for the design team to individually fabricate the panels then hinge them together. Having only five sections in design helps to consolidate the amount of components that need to be transported and kept track of. Some of the drawbacks for the foldable design include high section weight, pinch points, and top section assembly difficulty. Although the sides and back section can fold to reduce the general size of the sections, the weight of each section goes up. High section weight can make it more difficult to maneuver the sections during transportation. The hinging element of the sections also adds to the potential for injury caused from pinch points when folding. Similar to the panels design, this design would require the assemblers to lift the top section about 7' high to attach it to the back and side sections. This action may be difficult and cumbersome for the assemblers.

#### *2.4 Evaluation of Preliminary Designs*

When comparing the three designs, the team assumed all designs will be as functional as a commercially available spider cage. Without functionality, the team decided on five factors to evaluate which design would produce the best product for the client. Factors were weighted as a percentage with the sum of all the factors equal to 100%. Working together, the design team scored each design relative to one another from 0-5 for each factor with 5 being the best and 0 being the worst. The design matrix with these scores can be found in Table 1.

Cost: Some of material for the spider cage was purchased (\$1,100 total) by the previous design team which left the current team with no funding from the client. However, the BME and ME department will contribute up to \$500 each for the project's budget. Since there is already material for the project and there is a budget supplied from each department, cost was not a high priority. It was weighted as a 10% factor of the total design.

Safety of Assembly: This was a heavily weighted factor in the design matrix as the client will be assembling the cage. All pinch points and heavy lifting must be considered while evaluating each design and the risk associated while assembling the cage. This category was not addressed by the client, but the team must consider this a very important factor as it is one of the largest risks of injury associated with the cage. The safety of assembly was weighted at 25% while evaluating the design as it pertains directly to the safety of the client.

Ease of Assembly: The assembly difficulty was addressed by the client, thus it was a highly weighted factor in choosing the final design. Assembly is important because the cage will be assembled by the client with the assistance of 1 to 3 others involved with UCP, thus, assembly will be with instructions but without training. Assembly and disassembly of the cage was weighted heavily because if the cage cannot be assembled and disassembled more than once relatively easily, it will not be able to move facilities as needed. The assembly was addressed by the client and was weighted as 25% of the design.

Portability (Weight & Size): This factor of the design was required by the client. Portability is important to the initial assembly of the cage and will also give the cage a much longer life as it might move facilities in the future. The assembly and portability aspect of the design helps distinguish this spider cage from existing spider cages on the market. Portability gives the physical therapist more freedom and flexibility by expanding potential therapy locations. This factor was weighted 15%.

Ease of Fabrication: Fabrication is a factor that mostly affects the design team. Given the year-long deadline, this is an aspect that the team must consider. The client has had previous teams on this project with no cage to show for it so it is important that the team has a deliverable product at the end of the year. However, a more difficult fabrication will only result in more work for the design team and reduce the likelihood of presenting the client with a finished product, thus it was a 15% factor.

Reparability: This factor is important to the life of the design. If there happens to be a failure on the cage, the client must be able to repair it with relative ease. This means that the components must be commercially available and if something fails that is not a main member in the cage, the client should be able to fix or replace the failure without disassembling the entire cage. This factor is for a scenario where a component on the cage fails and is not expected, however, it must be considered in order to guarantee a longer life for the cage, thus it was a 10%.

**Table 1.** Design matrix of the three preliminary designs.

Design Considerations	Weight	Panels		Telescoping		Foldable	
		Score	Weighted	Score	Weighted	Score	Weighted
Cost	10	3	6	4	8	3	6
Safety of Assembly	25	2	10	4	20	2	10
Ease of Assembly	25	2	10	4	20	3	15
Portability (Weight & Size)	15	4	12	3	9	2	6
Ease of Fabrication	15	5	15	1	3	5	15
Reparability	10	4	8	2	4	3	6
SUM	100		61		64		58

After evaluating the three designs, the team will move forward with the telescoping design. The ability for the client to assemble the top of the cage with the sides at a lower level is what gave this design an advantage. This increased the safety and ease of assembly, which are the criteria that are most important to this design. The disadvantages to this design, relative to the other designs, are the portability of the sections as well as the difficulty of fabrication. Portability is less of a factor as the cage will originally be moved to the UCP facility and then

once again only if UCP changes facilities. Difficulty of fabrication is mostly a factor for the design team, thus it is weighted less and a lower score does not deter the team completely from that design. Although it will be most difficult to make the telescoping design, it will be the best design for the client's requirements.

### *2.5 Material Change and Proposed Final Design*

After giving the preliminary presentation, the team was informed that the galvanized steel and other materials obtained by the previous spider cage team would not be available to use in the final design. The preliminary designs covered in sections 2.1 through 2.4 were made with the assumption that the galvanized steel would be the material used for the final cage. Thus, the designs were made to accommodate the high weight of the steel and keep the design modular and as easy to assemble as possible. The team chose instead to use extruded aluminum from 80/20, which is a much lighter material than galvanized steel. Modifications were made to the panel design outlined in section 2.1 to keep the final cage design modular and increase ease of fabrication. The team worked with Price Engineering - an 80/20 aluminum distributor - to verify that the modified panel design (Figure 5) would be able to withstand stresses placed on it from both normal use and when the cage is used incorrectly.

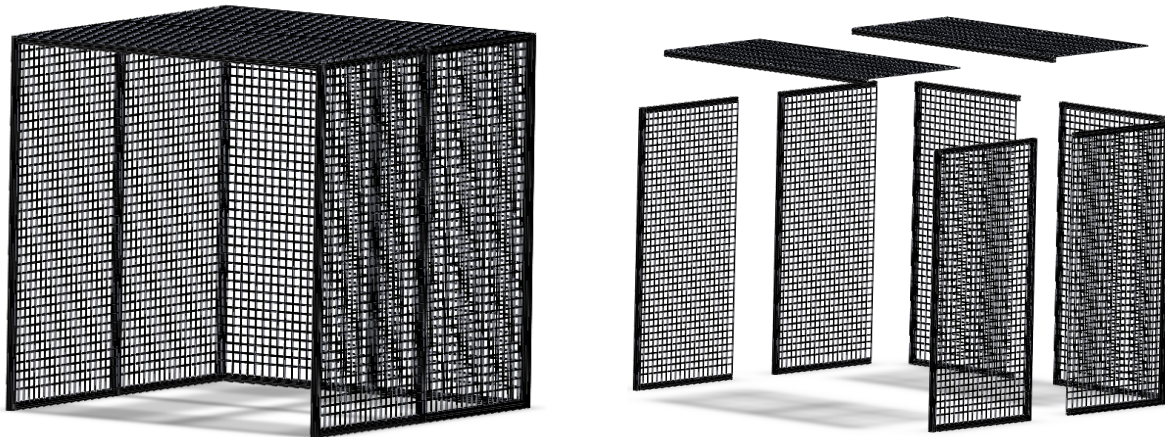

**Figure 5.** Left: Shown is a three-dimensional model of proposed final design. Right: The exploded view of the proposed final design. This design models the preliminary panel design but with a different material and fewer frame members.

There were a few specific considerations the group discussed with Price Engineering. Some of the considerations were the size and series of the 80/20 extrusions. It was initially suggested to the group to use the 1.5" x 3" cross sectioned aluminum extrusions for the vertical members and the horizontal top cross member of the cage, which would have increased the cost of the cage by over \$500. The 1.5" x 1.5" cross sectioned aluminum extrusions provide more than enough strength to support the vertical loads the cage would take, but there was slight concern that the cage would rack from side to side while in use. In order to compensate for the possibility of racking, angled support members were added to increase lateral stability, therefore, the 1.5" x 1.5" extrusions were selected for the cage. There are multiple series of

profiles that can be selected for the extrusions. Some extrusions are hollow to decrease the weight of the material and reduce cost, but there is a reduction in strength for these series relative to the others. It was determined by the group that the 1515-LS (1.5" x 1.5" Lite Series) would be satisfactory for the cage and reasonable in price.

The goal of the discussion with Price Engineering was to best utilize the features of the material. Using the material to its fullest design potential allowed the team to reduce the amount of material needed to construct the cage and reduce the cost. A minimalistic, yet comprehensive design was finalized by the group and a list of the necessary materials was developed by Price Engineering (Appendix B). An image of the final cage can be seen in Figure 6.



**Figure 6.** Picture of the prototype spider cage that the team assembled.

### **3.0 Fabrication**

#### **3.1 Materials**

The material selected for the final design was extruded aluminum with T-slot profiles that utilize steel fasteners and aluminum brackets. The brand name of the extrusion/fastener system is 80/20. In general, 80/20 provides a variety of general design benefits, and many of them are directly applicable to the spider cage design. Some of the benefits are as follows: modularity, high strength-to-weight ratio, lightweight, and easy machinability/assembly. The modularity of the 80/20 system comes from the T-slot profiles that allow for adjustable connection points. Connections can be made all the way along the axis of the extrusions on any of the four sides. Modularity from the T-slots allows for a design with virtually any connection scheme and allows for more design freedom. Modularity also helps increase the portability of the design through easy assembly/disassembly. The 80/20 extrusions are made from 6105-T5 Aluminum Alloy. This alloy has a yield strength close to that of A36 Carbon Steel, yet it is roughly a third of the weight by volume [11]. Since the cage needs to be portable, 80/20's high strength-to-weight ratio is highly advantageous. The aluminum extrusions seem to be one of the lightest structural materials (within budget) that can provide the necessary strength and versatility. The only

machining necessary when using the 80/20 aluminum extrusions is when cutting them to length and boring holes for fastener connections. The material does not require welding or any other laborious manufacturing techniques to connect members together. Overall, the material provides multiple benefits that will help ease the design process and fabrication of the final product.

### 3.2 Assembly

The final design of the cage uses 80/20 which allows any portion of the cage to be completely disassembled. Since 80/20 has this characteristic, the team had to carefully identify and establish the portions of the cage that were intended to remain connected as modular sections. If the sections are too small, additional complications such as losing parts, confusion, and other unnecessary complications could be added to the assembly process. If the sections are too large, they may be cumbersome to position during assembly and/or difficult to transport. The team intends to have each side of the cage separated into two sections (each 3' x 6' mesh section and the peripheral extrusions). The top of the cage will likely separate into two sections as well (each with two 3' x 3' mesh sections and peripheral extrusions). The composition of these sections and the order they are assembled may be altered slightly to help ease the assembly process as the assembly of the cage is standardized in the upcoming months. A document outlining initial assembly can be found in Appendix C.

## 4.0 Testing

### 4.1 Mesh Deflection

The team considered two different wire mesh sizes for the cage. The first mesh option consisted of a 2" x 2" square meshing whereas the second option was 1" x 1" square meshing. When the spider cage is in use, loads will be applied to the wire mesh and it is important that the mesh is able to withstand these loads without extreme deflection or permanent deformation. To perform the mesh deflection test, 2' x 2' sample panels of wire mesh were clamped to a flat surface and subjected to hanging loads of 5 to 50 lbs in 5 lb increments (Appendix D). For most spider cage exercises, there are at least four connection points bearing load to different parts of the mesh and the team does not anticipate any more than 50 lbs being supported by a single point on the meshing. The measured deflection from each load was recorded and plotted on a load vs. deflection graph which was then used to compare the two mesh sizes. Images from testing are shown in Figure 7.

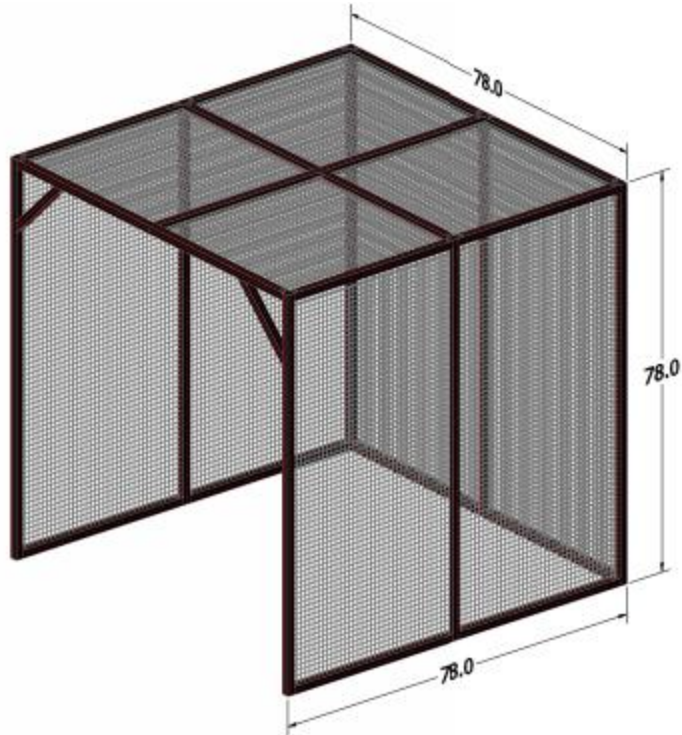



**Figure 7.** Top: A picture of mesh deflection testing setup with no initial weight. The wooden plank was used across the top of the mesh to reference a horizontal measuring point. Bottom Left: A picture of the 1" x 1" mesh with 50 lbs applied. Bottom Right: A picture of the 2" x 2" mesh with 50 lbs applied.

#### *4.2 Beam Deflection*

Before ordering the materials, the team was able to use the 80/20 Inc. website [11] for a computational estimate on the beam deflection for the different members of the cage. Deflection was calculated using the same length and material that the team ordered. When analyzing the deflection, the team chose to simulate the members as "supported" on each end rather than "fixed". Using this condition is a more conservative approach than trying to account for the exact moments taken by the fixed ends. The test resulted in slightly higher deflection compared to the fixed ends configuration and is likely more than the cage would actually experience. On the top of the cage there are two 75" members, one connecting front to back and one across the front. There are also two members that are each 36.75" connecting the middle beam to the sides (Figure 8). Reports from the 80/20 Inc. deflection calculator are attached in Appendix E.

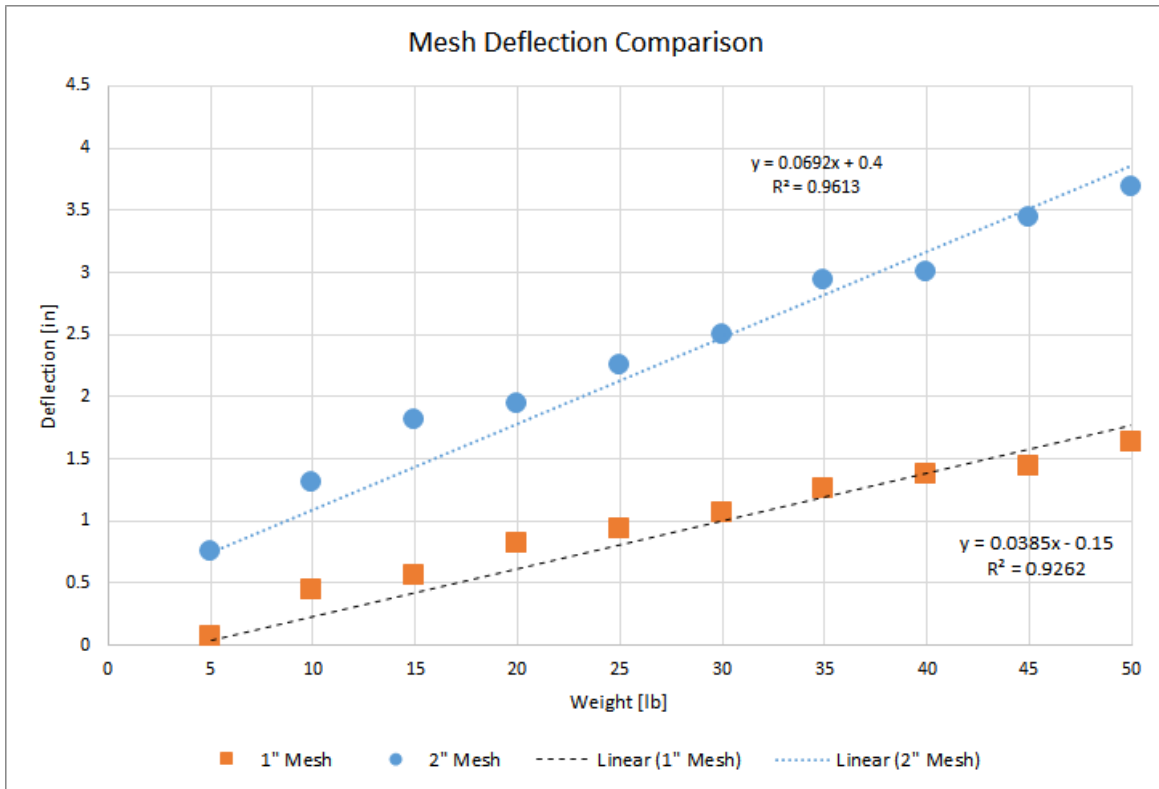

**Figure 8.** Above is the CAD image of the proposed final cage design provided by Price Engineering.

## 5.0 Results

### 5.1 Mesh Deflection

Deflection testing was performed on each sample of the mesh in order to determine the deflection and/or permanent deformation caused by a load of up to 50 lbs at any one point on the mesh. The results of this test were plotted on a load vs. deflection graph (Figure 9) and analyzed. The 1" x 1" wire mesh showed less deflection for any given load than the 2" x 2" wire mesh did. The 1" x 1" mesh also had a smaller slope meaning it had a slower rate of deflection than the 2" x 2" mesh.



**Figure 9.** This graph shows the load vs. deflection graph generated from mesh deflection testing. The 1" x 1" mesh deflected less and at a slower rate compared to the 2" x 2" mesh.

The permanent deformation of both meshes were observed after each load and the 2" x 2" mesh started permanently deforming at 30 lbs. After the 50 lb weights were removed, the permanent deformations were observed on each mesh. The 1" x 1" wire mesh showed no permanent deformation while the 2" x 2" wire mesh showed a permanent deformation of 0.75" with damage to the thermoplastic wire coating from the weight (Figure 10). A table of all deflection values during the mesh testing can be found in Appendix F.

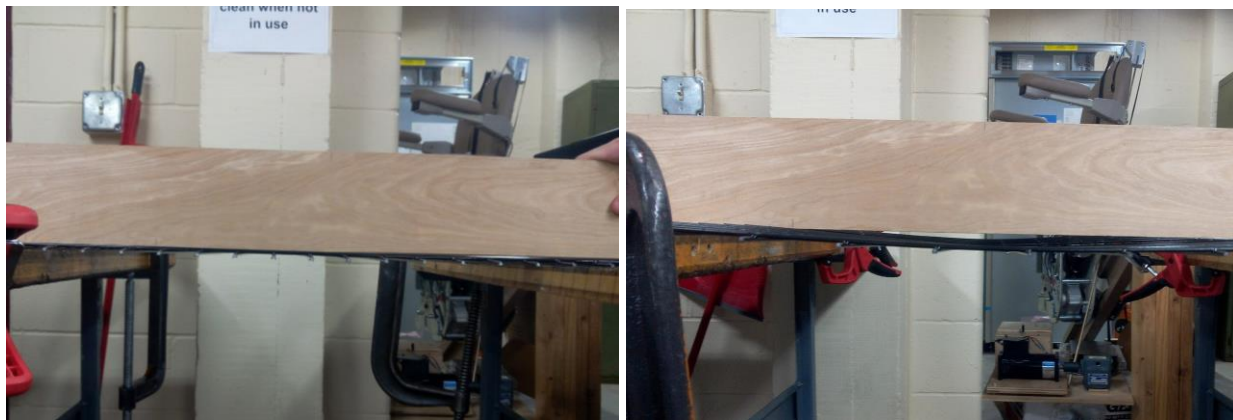

**Figure 10.** Left: Pictured is the 1" x 1" mesh after mesh deflection testing. The mesh returned to its original, preloaded shape so there was no permanent deformation. Right: Pictured is the 2" x 2" mesh



after mesh deflection testing. Permanent deformation of 0.75" can be seen after the weights were removed because the mesh did not return to its original shape.

### *5.2 Beam Deflection*

An online calculator from the 80/20 Inc. company was used to calculate beam deflection with a point load of 300 lbs. At first, the team used the original length of the top members at 75" and the 1515-LS series, this resulted in a deflection of 1.3752" which is too high for the cage application. With the angled members, the free length of the front top member was reduced to 50". This reduced length decreased the deflection of the cross member to 0.4045" with the 300 lbs load. For an evenly distributed load of 300 lbs would cause the beam to deflect 0.2528". A distributed load is more representative of what the cage will see with the 300 lbs max load, however, we compared the beams to a single point load as this is the worst case scenario.

## **6.0 Discussion**

The 1" x 1" mesh opening performed much better than the 2" x 2". Most importantly, it did not plastically deform after testing, which means this wire mesh will be much more durable than the 2" x 2" mesh which did plastically deform. Larger wire mesh openings were the primary choice before testing as they allow any carabiner to be attached to the mesh and this mesh was also cheaper per square foot. However, after testing the two options, the large deflection and the plastic deformation to the mesh removed it as an option. The team could not sacrifice the strength and durability of the cage for cost and ease of use. Smaller openings resulted in less than half the deflection of the larger openings at the maximum load (50 lbs) and no permanent deflection. After this testing, the 1" x 1" openings were the clear choice for wire mesh.

The beam deflection testing proved that the 1515-LS series could be strong enough for the spider cage. In order to reach this strength the cross member's free length needed to be reduced. Using angled members to reduce the length, the deflection was 0.4045", around 29% of the previous deflection. The distributor stated they have a cutoff for deflection at one inch, the deflection of the 50" member is well below this mark and will be sufficient for the cage application. Angled members reduce the free length of the cross member as well as transfer more of the load to the vertical members, which will make the horizontal beam stronger. The beams are also supported by the members that cross them and are pinned to other vertical members, which is not taken into account in the beam deflection calculator. Deflection on the beams should be less than calculated due to this extra support.

## **7.0 Conclusion**

Spider cages are useful physical therapy tools for children with motor conditions such as cerebral palsy. The goal of spider cage therapy is to help patients improve balance, gain muscle strength, and develop coordination. Current spider cages on the market cost at minimum \$4,000 and because of the high cost, the client tasked the team with constructing a design with the same functionality as current cages but for a more affordable price. The final design was assembled from extruded 80/20 aluminum and thermoplastic wire mesh panels. The overall cost of the design was about \$1,700 which is less than half the price of commercial spider cages.

The team was unable to complete testing of the fully assembled spider cage this semester and plans to perform testing for stability, durability, and functionality in the coming semester. There are a few options the team will explore to make the cage more rigid and as safe as possible for the client. Currently the bottom members of the cage are capable of moving

if the cage is pushed with enough force. To ensure that the cage does not move and also to prevent racking of the cage, the team will explore the possibility of attaching the cage to a base. Improving the portability of the cage will come with studying the cage and understanding which parts of the cage do not need to be disassembled. The team needs to keep the size of each section within the specifications, but have as much assembled on each section as possible. The top section currently presents a problem with its portability, and will need to be adjusted for the client. It is currently one large section, which will require either a full assembly at the client's facility or reduced portability. In order to fix the top section, the team will look into machining a horizontal member to allow for two separate panels on the top of the cage, increasing the portability of that section. While increasing the mobility of the cage, this would also improve the ease of assembly. The top was fairly difficult to assemble in relation to the rest of the cage; the previous adjustment would make that portion of the assembly much easier for the client. The team also plans to write assembly instructions for the client. There were no instructions for the team's initial build which made the process take around four hours. Using experience from multiple assemblies and disassemblies, the team will come up with detailed instructions along with a labeling system for the client. The team was able to assemble a full scale design and future testing will be conducted to optimize the cage.

## **8.0 Acknowledgements**

The team would like to thank and recognize all of the individuals who provided guidance throughout the semester. A special thank you to our client Matt Jahnke for providing us with a meaningful project and for answering our questions throughout the semester. We would also like to thank Dr. Towles, from the Biomedical Engineering department, and Travis Dick, from the Mechanical Engineering department, for their advising and flexibility with the team. A big thank you to Rob Bewalda and his team from Price Engineering for his continued communication with us and for helping with the ordering and costs of materials for the spider cage. We would like to thank the past BME design team as well as occupational therapy students Victoria Larkin and Emily Katz for providing us with design suggestions. Lastly, we would like to thank Heidi Ploeg for allowing us to build our structure in her lab space.

## **References**

- [1] UCP, 'UCP of Greater Dane County', 2015. [Online]. Available: [www.upcdane.org](http://www.upcdane.org). [Accessed: 7- Oct- 2016].
- [2] "Products/Equipment," in Genius4Kids, 2011. [Online]. Available: <http://www.genius4kids.com/Main/10-Equipment-E1.htm>. Accessed: Dec. 13, 2016.
- [3] Cerebral Palsy Alliance, 2013. [Online]. Available: <http://www.cerebralpalsy.org.au/what-is-cerebral-palsy/facts-about-cerebral-palsy/>. Accessed: Dec. 13, 2016.

[4] K. Stern, "Prevalence of Cerebral Palsy," in MyChild at CerebralPalsy.org, cerebralpalsy.org, 2015. [Online]. Available: <http://www.cerebralpalsy.org/about-cerebral-palsy/prevalence-and-incidence>. Accessed: Dec. 13, 2016.

[5] Center for Disease Control and Prevention, "Data & Statistics for Cerebral Palsy," CDC, 2016. [Online]. Available: <http://www.cdc.gov/ncbddd/cp/data.html>. Accessed: Dec. 13, 2016.

[6] A. Colver, C. Fairhurst, and P. O. D. Pharoah, "Cerebral palsy," (in English), *The Lancet*, vol. 383, no. 9924, pp. 1240-9, 2014 Apr 05 2015-02-07 2014.

[7] M. D. Sewell, D. M. Eastwood, and N. Wimalasundera, "Managing common symptoms of cerebral palsy in children," (in English), *BMJ : British Medical Journal*, vol. 349, 2014 Sep 25 2016-04-03 2014.

[8] NIH, 'NINDS Cerebral Palsy Information Page', 2016. [Online]. Available: [http://www.ninds.nih.gov/disorders/cerebral\\_palsy/cerebral\\_palsy.htm](http://www.ninds.nih.gov/disorders/cerebral_palsy/cerebral_palsy.htm). [Accessed: 7- Oct-2016].

[9] L. Mehl-Madrona, 'Spider Therapy', 2001. [Online]. Available: <http://www.healing-arts.org/children/cp/cpspider.htm>

[10] A. Crawford, *Spider Cage* 5. 2014.

[11] "80/20 Inc. - t-slotted aluminum framing system," 2016. [Online]. Available: <https://www.8020.net/>. Accessed: Dec. 3, 2016.

## Appendix

### A. PDS

#### Product Design Specifications

**Client:** Mr. Matt Jahnke  
**Advisor:** Joseph Towles  
**Team:** Kevin Collins [kdcollins2@wisc.edu](mailto:kdcollins2@wisc.edu) (Leader)  
Darcy Davis [darcy.davis@wisc.edu](mailto:darcy.davis@wisc.edu) (Communicator)  
Sheetal Gowda [sgowda@wisc.edu](mailto:sgowda@wisc.edu) (BSAC)  
Breanna Hagerty [bhagerty@wisc.edu](mailto:bhagerty@wisc.edu) (BWIG)  
Stephen Kindem [kindem@wisc.edu](mailto:kindem@wisc.edu) (BPAG)

---

#### **Function:**

A spider cage is a structure that is used by therapists to help develop muscles of patients with muscle disorders, specifically, cerebral palsy. Patients develop muscle strength through the use of therapy bands that can be attached to various points on the spider cage. Commercial spider

cages are available, but are expensive. This spider cage needs to be made with the materials already purchased by the client, transportable, able to be set up by the client and also support the any patient.

### **Client Requirements:**

- The cage shall be able to be transported by trailer
  - The structure will need to fit through a doorway.
- The client cannot offer any budget.
- The cage shall be able to be assembled by the client (2-4 assemblers), must include instructions.
- Locations of where bungees can be attached to the cage
  - The Spider Cage shall have members on the three walls and the ceiling of the cage that are moveable. This will allow the client to attach therapy bands to any location on each wall and the ceiling of the cage.
- The cage shall be able to hold 350 lbs. of weight from any point on the cage.
- Therapists shall be able to reach any point on the cage to attach a therapy band. A maximum height shall be set to 7'.
- The cage shall be able to fit any size patient.

### **Design Requirements:**

#### **1. Physical and Operational Characteristics**

- a. Performance Requirements:** The cage must be able to hold 350 lbs from any structural component/frame member or resistance band connection point. The cage must have at least four adjustable/movable resistance band connection points on each section of the cage (top, back, left side, right side). The maximum height of the cage must not exceed 7'. Any portion of the cage used for resistance band connections or adjustments may not exceed a maximum height of 7'. There must be enough room within the cage for patient and physician to work comfortably and simultaneously. The cage must be modular for transportation and installation using a maximum of four persons and a generic towable trailer. Modular sections must be able to fit through a standard 82" X 42.5" doorway.
- b. Safety:** Ensure the cage can perform as expected with a safety factor of 3 when a load is applied in a "worst-case" loading scenario. Mark, protect, or remove all possible pinch points. Use non-corrosive and non-toxic materials. Remove all sharp edges. Develop an instruction manual informing users of proper lifting and handling techniques to avoid injury when transporting. Develop a maintenance plan for maintaining and cleaning intricate/detailed portions of the cage to avoid dust/dirt build up.

- c. Accuracy and Reliability:** Resistance band connection points must have fixed adjustment locations or position references for tracking patient progress. Connection points for the modular sections must have appropriate tolerances for proper rigidity while in use, yet must they must have enough clearance for assembly/disassembly.
- d. Life in Service:** The cage is expected to remain functional for as long as possible without replacing structural/critical components and while being used an average of 6 times a day.
- e. Shelf Life:** Cage and its components should be stored in a dry, temperature controlled area.
- f. Operating Environment:** The cage will be used in a clinical setting such as a physical therapist's office as well as in the patient's home. Not meant for climbing, only to support body weight via bungee cords.
- g. Ergonomics:** Cage must be easy and relatively quick to assemble and disassemble; instructions for doing so should be included with cage.
- h. Size:** Large enough for a therapist and patient to stand up comfortably and perform exercises but small enough to fit in a trailer. The height must not exceed 7 ft.
- i. Weight:** There is currently no minimum weight, however, the weight should not compromise the stability of the cage. If it is designed as a kit to be assembled, each piece of the kit must have a low enough weight to allow it to be transported to and from a trailer and must be small enough to fit through a door.
- j. Materials:** The material should be as lightweight as possible while still retaining its structural integrity. An ideal material may be rigid plastic, as opposed to steel, however, this may exceed the project's budget. Overall, the heavier the material, the more pieces the cage must be disassembled into to allow for easy transportation of the cage.
- k. Aesthetics, Appearance, and Finish:** The cage should be free of sharp corners or places that could snag on clothing or the harnessing itself. If the cage folds, the folded structure must also not pinch the customer while it is being transported. The functionality of the cage is more important than the appearance, but the cage should appear clean, with no points of concern such as material defects visible. Harnessing for the patient should look or be professionally sewn with sturdy attachments to the bungee cords.

## 2. Production Characteristics

- a. Quantity:** Only one spider cage needs to be created and tested, there will be no mass manufacturing of the design. An instruction manual on how to assemble the cage and a fabrication manual on how to build the cage should be included.
- b. Target Product Cost:** Spider cages go for ~\$4,000, therefore, a final cost that is less than half of this is the desired target.

## 3. Miscellaneous

- a. Standards and Specifications:** None required as of now.
- b. Customer:** The cage is being designed for a patient with cerebral palsy. There is no specific customer that this product is being built for so the only customer requirements are that the cage support the height and weight of a given patient.
- c. Patient-related Concerns:** The cage will need to be used with a patient under the supervision of an occupational therapist.
- d. Competition:** There are a few cages available online for purchase but they are not as similar to the design that the client, Mr. Jahnke is looking for.

### *B. Material List*

Tag	Part #	Qty	Length Each (or area)	Units	Total Wgt (lbs)	Description Note:all extrusion dimensions start at the left end	Each \$	Price \$
A	1515-LS	7	78.000	IN	47.91	1.5" X 1.5" LITE SMOOTH T-SLOTTED EXTRUSION	35.10	245.70
C	1515-LS	1	75.000	IN	6.58	7050 in S @ 37.500; 7040 in A Left; 7040 in A Right	33.75	33.75
B	1515-LS	1	75.000	IN	6.58	7060 Right; 7040 in D Left	33.75	33.75
D	1515-LS	1	36.750	IN	3.22	7040 in A Left; 7040 in B Right	16.54	16.54
F	1515-LS	12	36.750	IN	38.70	7040 in B Left; 7040 in B Right	16.54	198.48
E	1515-LS	1	36.750	IN	3.22	7040 in C Left; 7040 in B Right	16.54	16.54
G	2472	6	19.727	SQ FT	78.41	1"X1" BLACK THERMOPLASTIC COATED WIRE CLOTH **PER DRAWING** (AD) 75.75IN x (AB) 37.5IN 7312 VERTICAL on corner C; 7312 VERTICAL on corner D; **PER DRAWING**	49.32	295.92
I	2472	2	9.766	SQ FT	12.94	1"X1" BLACK THERMOPLASTIC COATED WIRE CLOTH **PER DRAWING** (AD) 37.5IN x (AB) 37.5IN 7312 HORIZONTAL on corner A; 7503 on corner B; 7505 on corner C; 7505 on corner D; **PER DRAWING**	24.42	48.84
H	2472	2	9.766	SQ FT	12.94	1"X1" BLACK THERMOPLASTIC COATED WIRE CLOTH **PER DRAWING** (AD) 37.5IN x (AB) 37.5IN 7505 on corner A; 7505 on corner B; 7505 on corner C; **PER DRAWING**	24.42	48.84
	7010	23		EA		Cut to Length 1.5" x 1.5" T-Slot and Tube	1.95	44.85
	7040	31		EA		Anchor Fastener Counterbore for 15S	2.60	80.60
	7050	1		EA		Access hole for 15S	1.95	1.95
	7060	1		EA		5/16-18 Tap For 1.5" x 1.5" Extrusions	1.95	1.95
	7095	4		EA		Shearing Expanded Metal or Wire All Sides <= 48in	10.25	41.00
	7100	6		EA		Shearing Expanded Metal or Wire Any Side > 48in	18.40	110.40
	7312	2		EA		Notch for 15 SERIES Anchor Fastener/Notch (Horizontal)	0.53	1.06
	7312	12		EA		Notch for 15 SERIES Anchor Fastener/Notch (Vertical)	0.53	6.36
	7503	2		EA		Notch Panel Corner for End Fastener 15 SERIES/Notch	0.53	1.06
	7505	10		EA		Notch Panel Corner for Extrusion Clearance 15 SERIES/Notch	0.53	5.30
J	2436	64		EA	10.56	15 S 1.5" MESH RETAINER W/ BACKING PLATE	5.25	336.00
K	2518	20		EA	6.00	15 S 1.5" DOUBLE MESH RETAINER W/ BACKING PLATE	8.15	163.00
L	2543	2		EA	3.36	1515 -LS X 18" 45 DEGREE SUPPORT	18.75	37.50
M	7413	1		EA		YOUR ORDER IS TAGGED PER YOUR BOM AT NO EXTRA CHARGE	0.00	0.00
	3114	104		EA	2.08	5/16-18 X .75" BHSCS	0.30	31.20
	3320	84		EA	3.36	5/16-18 X 11/16" FBHSCS & ECON T-NUT	0.60	50.40
	3360	31		EA	3.10	15 S ANCHOR FASTENER ASSEMBLY	3.15	97.65
	3380	1		EA	0.05	15 S END FASTENER W/5/16-18 SCREW	1.60	1.60

Total weight for 1 kits: **239.01**

Total amount for 1 kits: **1950.24**

\*the team received a 20% discount reducing the initial cost of materials to \$1,573.47. Shipping cost for the materials was \$129.28 bringing the total cost of the materials to \$1,702.75.

### C. Assembly Process

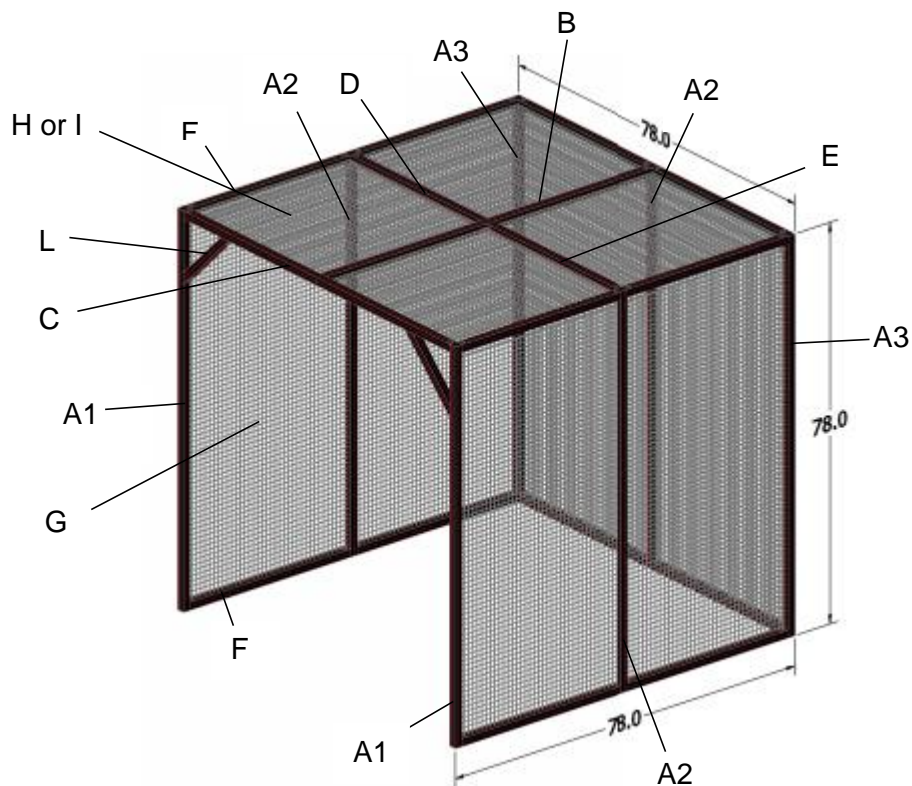

\*Letters in above image are based off of parts corresponding to Appendix B  
 The cage was assembled in panels and the original attachment process is as follows:

### Sides

- Each bottom F member has 2 single mesh retainers attached to mesh G about 15" apart
- Each top F member has 2 single mesh retainers attached to mesh G and 2 adjacent single mesh retainers attached to mesh H or I about 15" apart
- A1 is attached to a top F and bottom F member with anchor fasteners
- A1 is attached to mesh G by 4 single mesh retainers equally spaced about 15" apart
- A2 is also attached to the mesh G that is attached to A1 with 4 double mesh retainers spaced about 15" apart
- A2 is also attached to another panel of mesh G on the opposite side with 4 single mesh retainers
- A2 is fastened to the top and bottom F members that are attached to A1 and another set of F top and bottom members via anchor fasteners
- A3 is attached to the mesh G from A2 with 4 single mesh retainers equally spaced about 15" apart
- A3 is also attached, in the same fashion, to another adjacent panel of mesh G
- A3 is attached to the top and bottom F members that are attached to the side A2 and to an adjacent set of top and bottom F members attached to the rear A2



## Top

- C is attached with anchor fasteners to both A1 extrusions
- C has 8 single mesh retainers about 15" apart attached to mesh H or I (same part)
- Angled members L are attached to C and both A1 extrusions with angled fasteners
- B is attached to C and the back A2 extrusion with anchor fasteners
- B is attached to all four H and I meshes via 8 double mesh retainers equally spaced about 15" apart
- D and E are connected to the side A2s and member B with fasteners
- D and E each have 2 double mesh retainers spaced 15" apart and are connected to the top 4 meshes

## D. Testing Procedure

### Mesh Deflection Procedure

**Purpose:** The purpose of the test is to determine deflection of each mesh (part # 2478 and 2472) on increasing load. The mesh will be loaded at 5 to 50 pounds and deflection will be measured at each 5 pound increment. Then end goal is to determine which mesh will deflect the least and implement that meshing into the final spider cage design.

#### Materials:

- 2' x 2' wire mesh samples (part # 2478 and 2472)
- 4 clamps (one for each corner of the mesh)
- one 5lb, two 10lb, and one 25lb weight
- two adjacent, flat surfaces to clamp wire mesh to (tables will be used)
- ruler to measure deflection
- reference point to measure deflection from
- carabiner
- string

#### Procedure:

1. Clamp each of the four corners of mesh number one to two adjacent tables
2. Tie sturdy string to each weight so as to form a loop that can be attached to a carabiner
3. Attach the 5lb weight to the middle of the mesh using the carabiner
4. Measure and record deflection from the reference point (located at the undeformed position of the mesh) to the deflected position of the mesh with the weight attached
5. Repeat steps 4-5 by adding weight in 5lb increments until load reaches 50lbs
6. Repeat steps 1-5 with mesh number 2
7. Use data points to construct a load vs deflection graph

### E. Beam Deflection Calculation

## Beam Supported Two Ends Deflection Report

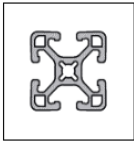
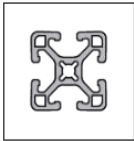
<b>Profile:</b> 1515-LS	<b>Yield Strength:</b> 35000 Lbs. / Sq. In. 241.3 N/mm <sup>2</sup>		
<b>Load:</b> 300 Lbs 136.08 kg	<b>Modulus Of Elasticity:</b> 10200000 Lbs. / Sq. In. 70326.5 N/mm <sup>2</sup>	<b>Moment Of Inertia X:</b> 0.1921 In. <sup>4</sup> 7.995805 cm <sup>4</sup>	<b>Moment Of Inertia Y:</b> 0.1921 In. <sup>4</sup> 7.995805 cm <sup>4</sup>
<b>Length:</b> 75 In 1905 mm			

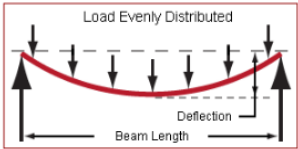
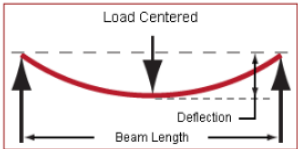
	<b>Deflection X</b> 0.8595 In. 21.8313 mm	<b>Deflection Y</b> 0.8595 In. 21.8313 mm
	<b>Deflection X</b> 1.3752 In. 34.93008 mm	<b>Deflection Y</b> 1.3752 In. 34.93008 mm

## Beam Supported Two Ends Deflection Report

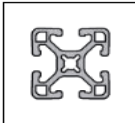
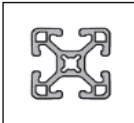
<b>Profile:</b> 1515-LS	<b>Yield Strength:</b> 35000 Lbs. / Sq. In. 241.3 N/mm <sup>2</sup>		
<b>Load:</b> 300 Lbs 136.08 kg	<b>Modulus Of Elasticity:</b> 10200000 Lbs. / Sq. In. 70326.5 N/mm <sup>2</sup>	<b>Moment Of Inertia X:</b> 0.1921 In. <sup>4</sup> 7.995805 cm <sup>4</sup>	<b>Moment Of Inertia Y:</b> 0.1921 In. <sup>4</sup> 7.995805 cm <sup>4</sup>
<b>Length:</b> 50 In 1270 mm			

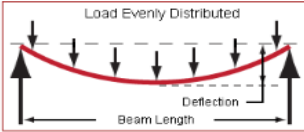
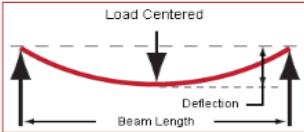
	<b>Deflection X</b> 0.2528 In. 6.42112 mm	<b>Deflection Y</b> 0.2528 In. 6.42112 mm
	<b>Deflection X</b> 0.4045 In. 10.2743 mm	<b>Deflection Y</b> 0.4045 In. 10.2743 mm

*F. Mesh Deflection Table*

<b>Weight [lb]</b>	<b>1" x 1" Mesh Deflection [in]</b>	<b>2" x 2" Mesh Deflection [in]</b>
5	0.0625	0.75
10	0.4375	1.3125
15	0.5625	1.8125
20	0.8125	1.9375
25	0.9375	2.25
30	1.0625	2.5
35	1.25	2.9375
40	1.375	3
45	1.4375	3.4375
50	1.625	3.6875

## G. Gantt Chart

Task	September				October			November				December			
	8	15	22	29	6	13	20	27	3	10	17	24	1	8	15
<b>Project R&amp;D</b>															
Preliminary Research	X	X	X												
Brainstorming				X	X										
Choose Design					X										
Order Materials											X	X			
<b>Fabrication</b>															
3D Modeling					X	X	X								
Assemble Cage													X		
<b>Testing</b>															
Mechanical Testing											X				
Product Revision												X			
Final Product														X	
<b>Deliverables</b>															
Progress Reports		X	X	X	X	X	X	X	X	X	X	X	X	X	X
PDS		X	X												
Preliminary Presentation					X	X									
Preliminary Deliverables					X	X									
Poster													X	X	
Final Deliverables														X	
<b>Meetings</b>															
Advisor		X	X		X	X		X	X	X	X		X		
Client			X		X										
Team		X	X	X	X	X	X	X	X	X	X	X	X	X	X
<b>Website</b>															
Update		X	X	X	X	X	X	X	X	X	X	X	X	X	X
Colored Cells: Projected Timelin															
X: Completed Tasks															