



THE UNIVERSITY  
*of*  
**WISCONSIN**  
M A D I S O N

# BME 300: Secondary Airline Mobility Device

# Secondary Airline Mobility Device

Client- Dan Dorszynski

Advisor- Dr. Aaron Suminski

Team -

Will Fox - Team Leader

Kendall Kupfer - Communicator

Justin DeShaw - BSAC

Grant Karlsson Ellifson - BPAG

Ben Ayd - BWIG



THE UNIVERSITY  
*of*  
**WISCONSIN**  
MADISON

# Overview

- ▶ Problem Statement
- ▶ Background
- ▶ Project Design Specifications
- ▶ Design Options
- ▶ Design Matrix
- ▶ Final Design
- ▶ Future Work
- ▶ References and Acknowledgments



# Problem Statement

- Airline travel for disabled passengers extremely difficult
  - Approximately 55 percent of air travelers with disabilities experience problems at airports (Bureau of Transportation Statistics)
- Work to build device to simplify overall process and create healthier flying environment for disabled individuals

# Background



Common aisle wheelchair

## Airline Travel with Wheelchair

- Transfer from passenger's wheelchair to aisle wheelchair
- Transfer from aisle wheelchair to seat
- This is done in reverse when plane lands

## Associated Risks

- Damage to passenger's wheelchair in cargo
- Risk of being dropped during any transfer

# Product Design Specifications

## Design Requirements:

- Minimize number of transfers during boarding process (four currently)
- Foldability/Stowability for when device is not in use
- Proper safety belts/harnesses
- Align current FAA and U.S Access Board Guidelines for Aircraft Boarding Chairs

# Design One - Compact Scissor Lift

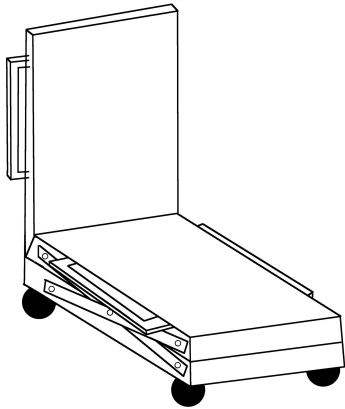

Figure 1: Angled view of collapsed chair

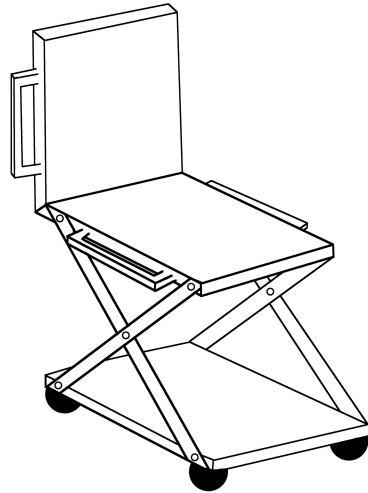

Figure 2: Angled view of extended chair

- Height adjustable
  - Accommodates for both onboarding and offboarding
- Scissor lift design lends to strong structural support

# Design Two - Two-piece Scissor Lift

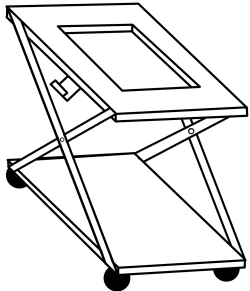
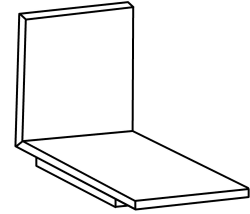

Figure 1: Two pieces separate

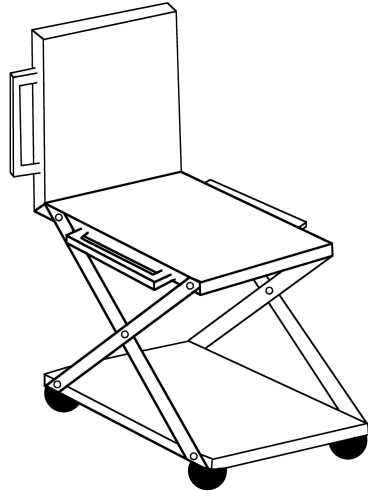

Figure 2: Two pieces together

- Two pieces
  - Chair portion
  - Wheels and support portion
- Chair portion is placed on wheelchair
- At gate, chair portion is lifted and placed on wheel and support portion
  - Secured together



# Design Three - Rigid Chair with Collapsible Back Wheels

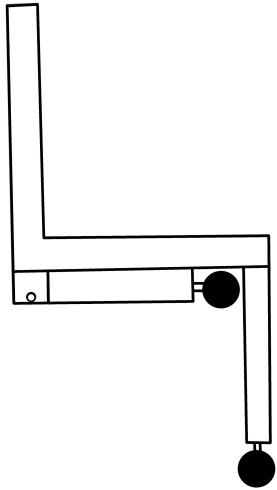

Figure 1: Side view

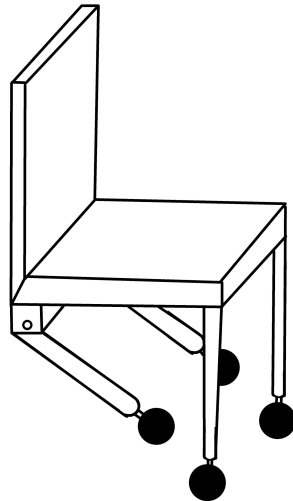

Figure 2: Angled view

- Slides over current wheelchair
- Spring loaded back legs
- Completely eliminates two transfers

# Design Four - Eagle Lift Variation



- Medical-grade hoist
- Designs would be large and arch over entire current chair

# Design Matrix

	Design 1 (Scissor Lift One Piece)		Design 2 (Scissor Lift Two Piece)		Design 3 (Folding Rear Wheels)	
Strength (25)	20	4/5	20	4/5	10	2/5
Size (10)	6	3/5	8	4/5	4	2/5
Cost (15)	9	3/5	9	3/5	12	4/5
Stowability (5)	4	4/5	5	5/5	2	2/5
Comfort (10)	4	2/5	6	3/5	8	4/5
Ease of Use (15)	9	3/5	9	3/5	15	5/5
Manufacturability (20)	18	2/5	18	2/5	16	4/5
Total (100)	64		65		67	

# Final Design

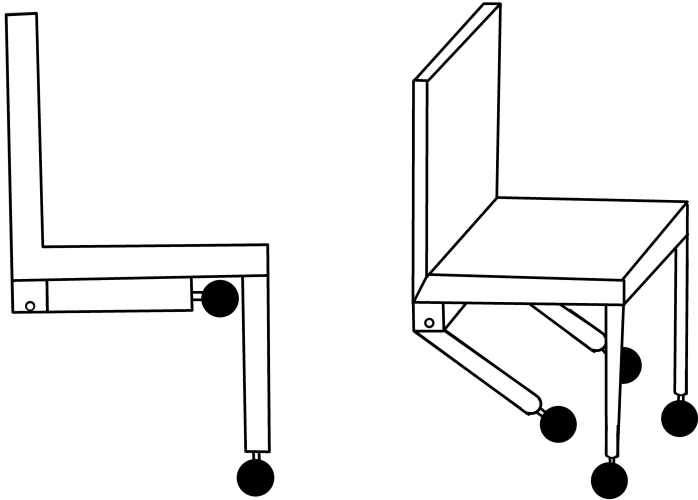

- Benefits
  - Minimal risk of dropping or injury
  - Most simple in terms of fabrication and use
  - Easy to explain process

## Concerns

- Weight bearing properties
- Stowability

# Future Work

- ▶ Choose and purchase materials
- ▶ Prototype fabrication planning and fabrication
- ▶ Prototype testing
- ▶ Challenges
  - ▶ Ensuring device has proper structural strength
  - ▶ Fabrication

# References and Acknowledgements

We would like to thank the following individuals their assistance thus far:

Dr. Aaron Suminski

Dan Dorszynski

Questions?

The background features a white space on the left and a complex, abstract composition of overlapping red and dark red geometric shapes on the right. These shapes include triangles and polygons of varying opacities, creating a layered, modern aesthetic.