

### Abstract

By 3D printing bone cutting guides for orthopedic surgery in-house, the cost of surgery is dramatically lowered. However, this technology is new and the usefulness of 3D printed cutting guides in a clinical setting is not known. By testing the accuracy, safety, and applicability of these guides, their feasibility will be determined.

### Problem Definition

#### Statement:

Dr. Jason Bleedorn, a veterinary surgeon at the UW Vet Hospital has tasked us with designing and analyzing the biocompatibility, accuracy, and fabrication process of 3D printing orthopaedic cutting guides for bone deformation surgery in animals.

#### Background:

- Bone deformities occur at any stage of life and for many reasons [1]
- Often times very painful, and can be fatal if not treated.
- Corrective osteotomy most common method to fix

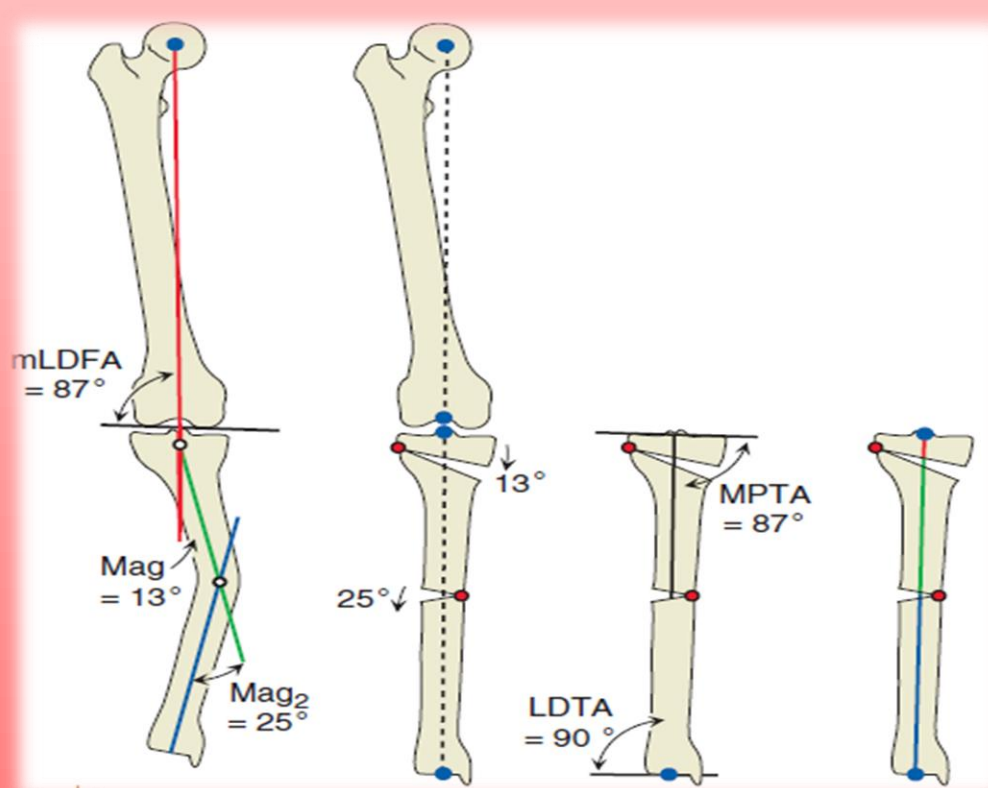

Figure 1. Corrective osteotomy Procedure [2]

#### Motivation:

- High level of accuracy needed
- Costly methods of current custom cutting guides
- Patient Safety

#### Current Products

- Visionaire knee replacement cutting guides [3]
- Stratasys 3D printed jigs [4]
- Patents

### Fabrication Process

1. Take images of the patient's bone
2. Using the CT images of the bone, import into MIMICS to create 3D mesh
3. Export to 3-matic to create contoured surface of bone
4. Create the cutting guide in 3-Matic and export as .STL
5. 3D print the cutting guide

### Test Specimen Designs

#### Previous Designs

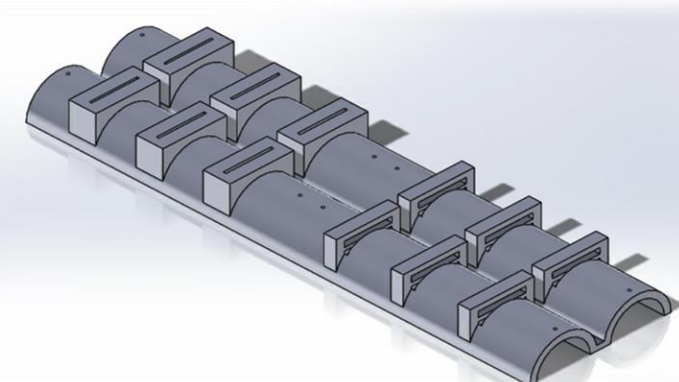

Figure 2. Previous design designs

- Printed 4 designs at once
- Varying opening sizes for the saw blade
- 2 designs have half walls to allow more freedom
- Includes pin holes + thermistor holes

#### Current Design

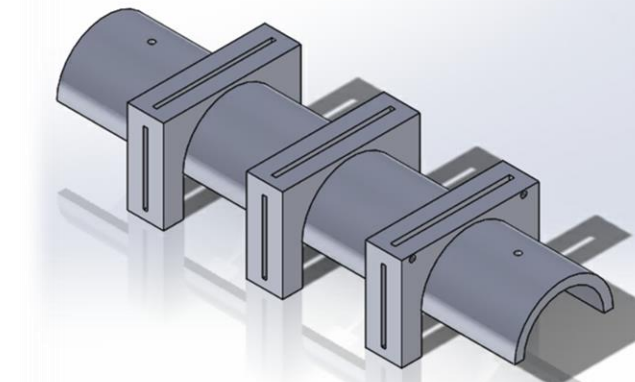

Figure 3. Current Design

- Widened the opening hole for saw blade
- Brought down legs for more support
- Added side openings to allow bone dust to escape

### Thermal Test

1. Thermistors are placed in the two small holes on the sides of each cutting channel.
2. Output voltage through the circuit is recorded by the cDAQ as the cut is made.
3. LabVIEW converts output voltage into temperature.
4. If the maximum temperature of the cutting process is below the glass temperature of the material, the guide is sufficiently heat resistant.

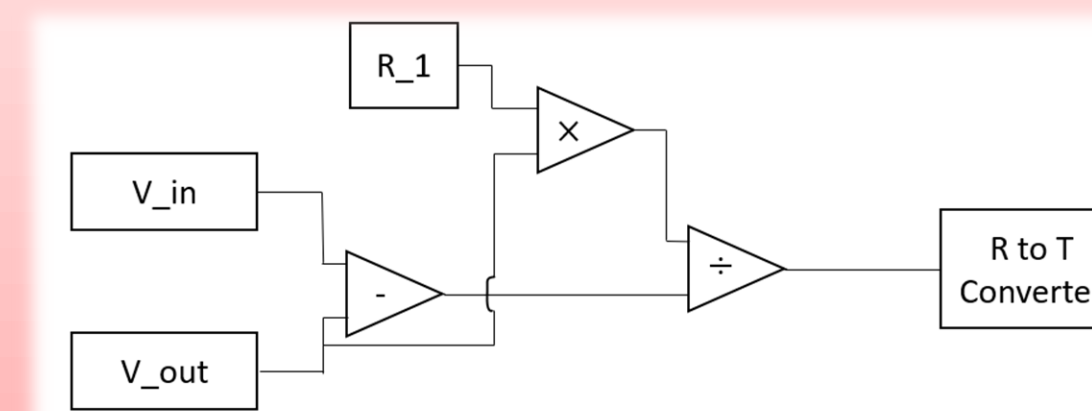

Figure 4. Block diagram of thermistor circuit

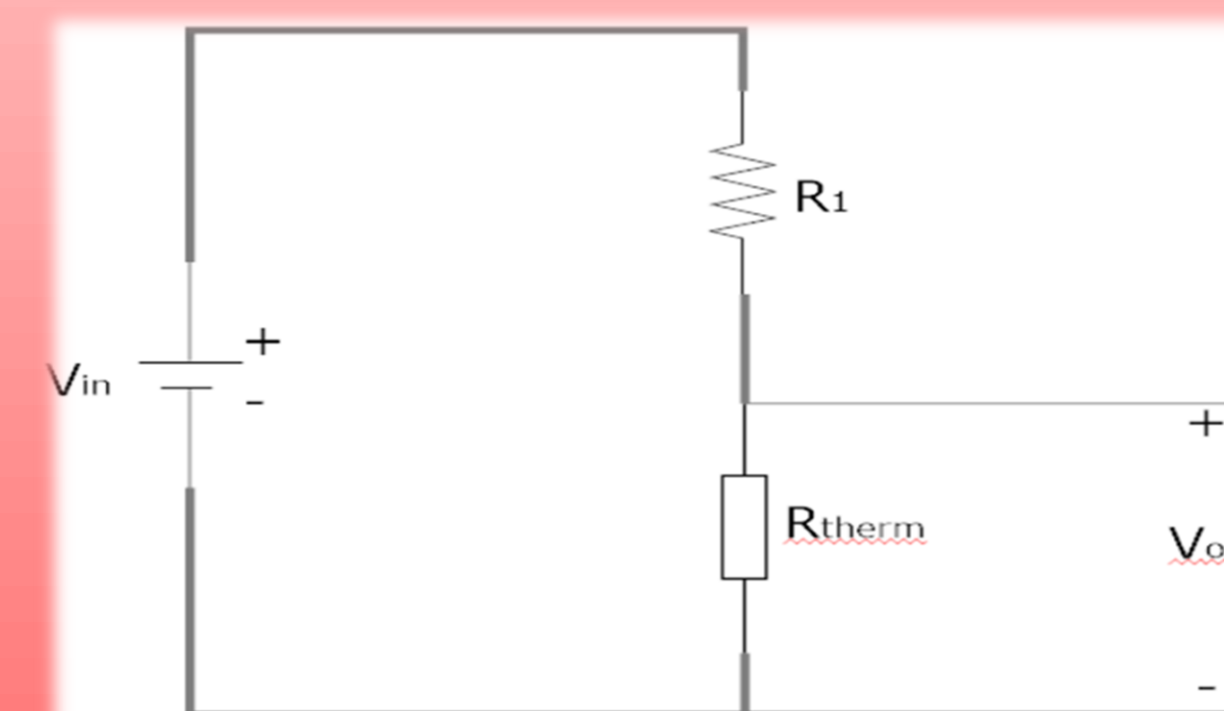
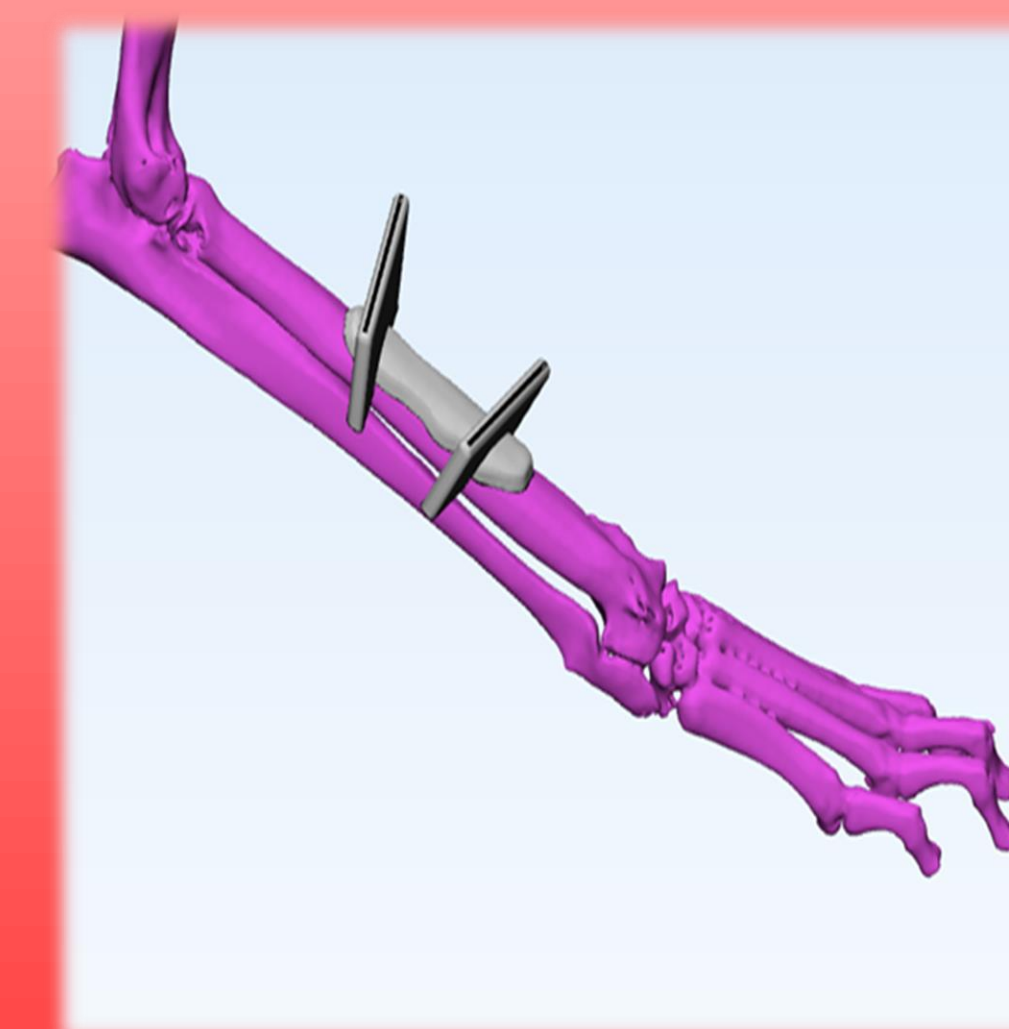

Figure 5. Schematic of thermistor circuit

### Debris Test\*\*

1. Take CT image of cutting guide before cutting
2. Simulate a cut using the guide
3. Take CT image of cutting guide post cut
4. Compare volumetric differences between the pre cut and post cut scans
5. Difference in volume indicates that material potentially wore off into the patient



### Results

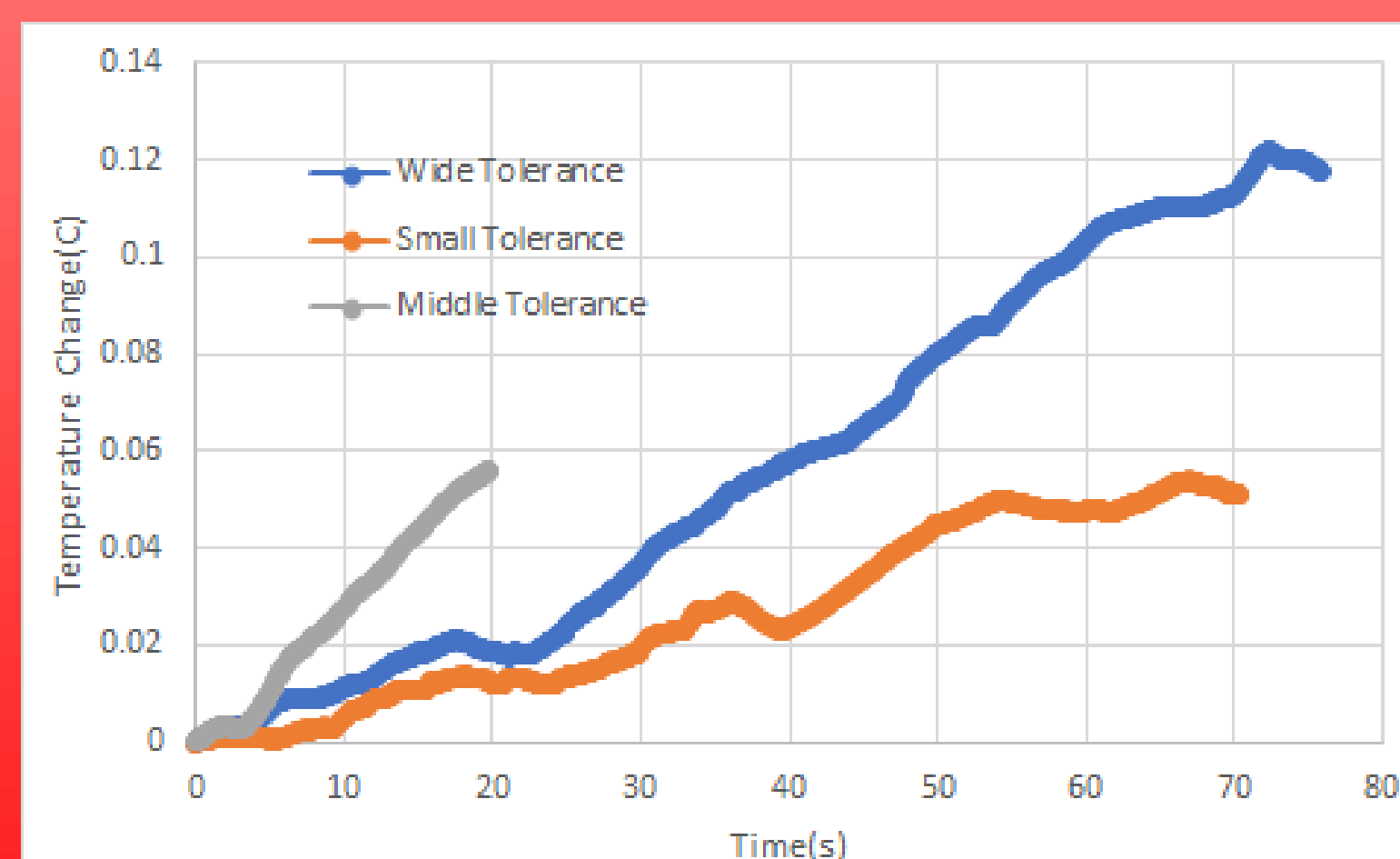

Figure 6. Thermal testing results at varying gap widths.

### Future Work

- Work with Calypso and other software to allow us to complete our volumetric comparison test
- 3D print guides custom to specific bone geometry in cadaver bones rather than bone analogue

### References

- 1) "Bone Deformities | RIAO", *Lifebridgehealth.org*, 2017. [Online]. Available: <http://www.lifebridgehealth.org/RIAO/BoneDeformities.aspx>. [Accessed: 08- Dec- 2017].
- 2) D. Paley, *Principles of Deformity Correction*. Berlin, Heidelberg: Springer Berlin Heidelberg, 2002.
- 3) "VISIONAIRE® Cutting Guides." *VISIONAIRE Technology Cutting Guides for Knee Replacement | Smith & Nephew - US Professional*, Smith & Nephew, [www.smith-nephew.com/professional/products/all\\_products/visionaire-technology/visionaire/](http://www.smith-nephew.com/professional/products/all_products/visionaire-technology/visionaire/).
- 4) Stratasys. "3D Printing & Additive Manufacturing." *Stratasys*, Stratasys, [www.stratasys.com/ve-Manufacturing/](http://www.stratasys.com/ve-Manufacturing/). *Stratasys*, Stratasys, [www.stratasys.com/](http://www.stratasys.com/) & Additive Manufacturing." *Stratasys*, Stratasys, [www.stratasys.com/](http://www.stratasys.com/).