

Rodent Rotation and Translation Stage (RRaTS)

Jamison Miller (Leader), Cory Van Beek (BSAC),
Kevin Koesser (Communicator), Alexis Edwards
(BWIG), and Aaron Patterson (BPAG)



Problem Statement

- The retina is frequently viewed through a stationary device
- Need 5 degrees of freedom
- Create a stage to hold a human eye or rodent which allows translational and rotational movements
- Pupil as the center of rotation

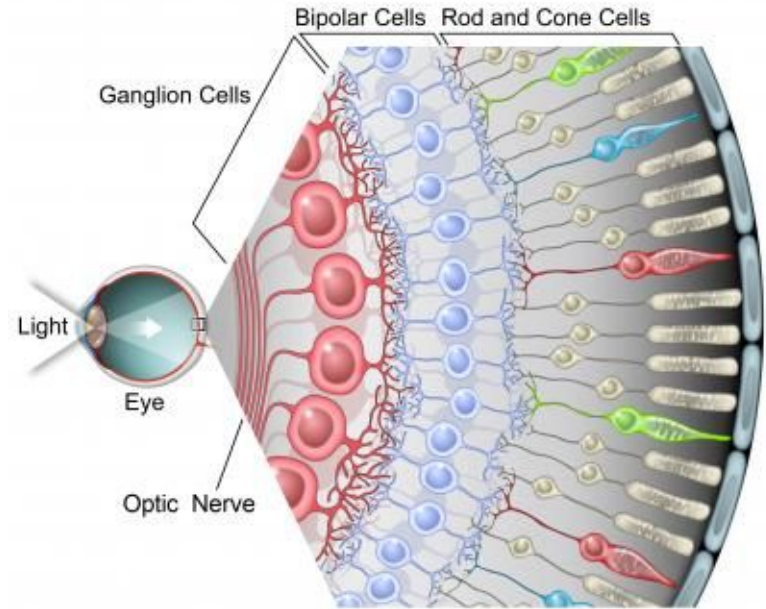



Background

Three main image subjects

- Laboratory mouse
 - 12.5 - 20 cm long and 12 -30 g
- Thirteen-lined ground squirrel
 - 33 cm long and 227g
- Ex-vivo human eye
 - 24 cm diameter



Existing Equipment

- TMC vibrationless microscopy table
- Kent infrared warming pads
- Adaptive optics scanning laser ophthalmoscope imaging (AOSLO)

Product Design Specifications

- 5 degrees of freedom:
 - Y and z rotation
 - Translation along all three axis
- 100 micron precision
- Interchangeable stages for different subjects.
 - detached human eye
 - a thirteen lined ground squirrel
 - a white mouse
- Sterilizable

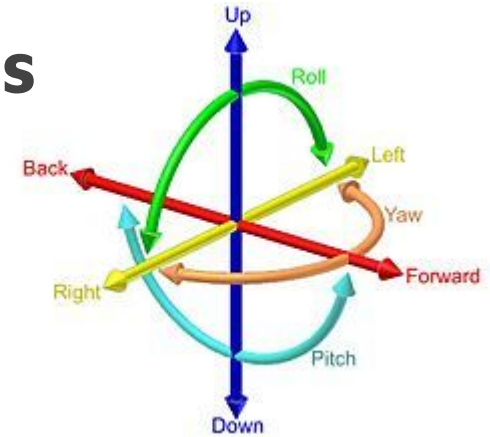



Design Criteria



- Precision
 - How accurate within 1 mm
- Usability
 - How easily stage can be adjusted (rotational/translational)
- Height
 - Below 15 cm
- Amount of Rotation
 - Amount that device can rotate around the focal point (pitch/roll)
- Ease of Build
 - For us to make and someone else to fabricate
- Cost
 - \$250 (manufacturing and testing included)
- Safety
 - How safe the device is for the user

Design 1 - The Park

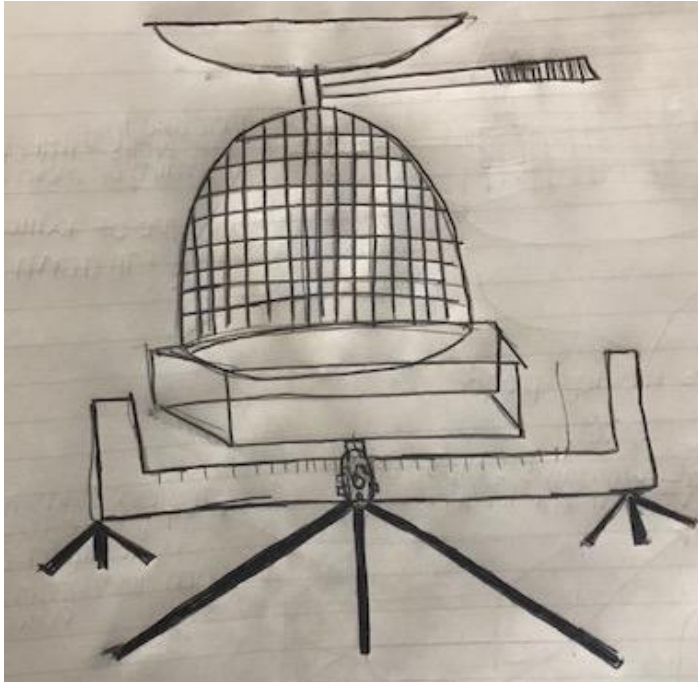

Design Features:

- A handle for precise rotational movement
- A hollow Semi-Circle for Rotational movement
- Small Rounded walls for movement and setting capabilities
- A gear track attachment for and translation.
- Tripod legs used for stability of the whole device

Design 2 - The Rigamortis

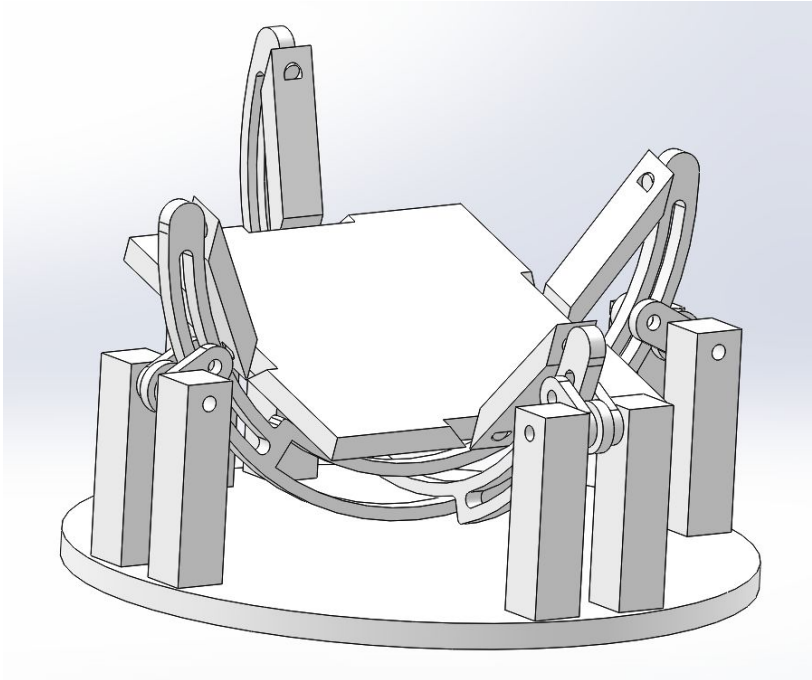

Design Features:

- Fine and coarse adjustment knobs
- Sliding tracks for rotational movement
- Hollow section in curved rack for the insertion of other curved rack piece
- Large square base
- Modular attachment for varying sized subject holders

Design 3 - The Rocking Chair

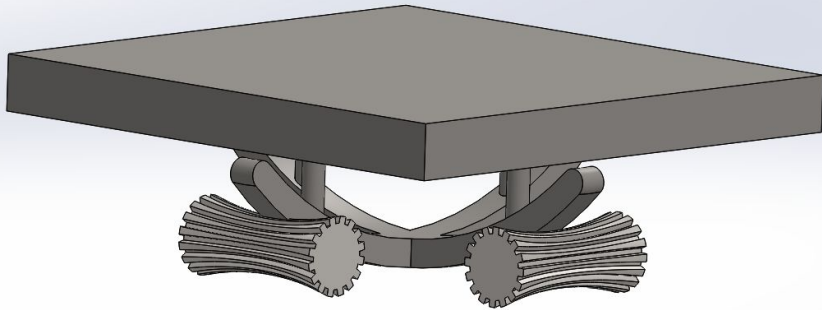

Design Features:

- Large, wide square stage
- Stage rests atop curved rack
- Curved gears allow rotation about the x and y axes
- One axis acts as a gear while the other acts as a sliding track.



Design Matrix

Design Aspect	Weight	Design 1: The Park Rank (1-5)	Weighted Rate	Design 2: The Rigamortis Rank (1-5)	Weighted Rate	Design 3: The Rocking Chair Rank (1-5)	Weighted Rate
Precision	35	3	21	4	28	4	28
Usability	25	3	15	5	25	2	10
Height	15	4	12	2	6	2	6
Amount of Rotation	10	2	4	3	6	1	2
Ease of Build	5	3	3	3	3	3	3
Cost	5	4	4	5	5	5	5
Safety	5	5	5	5	5	5	5
Total:	100		64		78		59



Future Work

- Draw up Solidworks designs for the translational movement in the x, y, and z coordinates
- Integrate The Rigamortis design into a piece for rotation around the z axis.
- Modify the current rotational designs
- Add modular pieces for imaging different subjects
- Test design



Acknowledgements

We would like to thank Dr. Rogers for his detailed explanation of the problem statement and we would also like to thank Dr. Suminski for his advice and help on this project with design and feedback on course deliverables.

References

1. E. S. Perkins and H. Davson, "Human eye," Encyclopedia Britannica, 22-Jun-2018. [Online]. Available: <https://www.britannica.com/science/human-eye>. [Accessed: 21-Sep-2018].
2. E. C. Cleary and S. R. Craven, "Thirteen-lined Ground Squirrels and Their Control," Internet Center for Wildlife Damage Management. [Online]. Available: <http://icwdm.org/handbook/rodents/13linedgroundsquirrel.asp>. [Accessed: 21-Sep-2018].
3. L. Ballenger, "Mus musculus (house mouse)," Animal Diversity Web, 1999. [Online]. Available: http://animaldiversity.org/accounts/Mus_musculus/. [Accessed: 21-Sep-2018].
4. Techmfg.com. (2018). CleanBench Laboratory Table. [online] Available at: <https://www.techmfg.com/products/labtables/cleanbench63series> [Accessed 1 Oct. 2018].
5. Kentscientific.com. (2018). Far Infrared Warming Pads | Mouse & Rat Warming | Kent Scientific. [online] Available at: <https://www.kentscientific.com/products/far-infrared-warming-pads/> [Accessed 1 Oct. 2018].
6. Merino, D. and Loza-Alvarez, P. (2018). Adaptive optics scanning laser ophthalmoscope imaging: technology update.