

Lower Extremity Strength Tester (LEST)



University of Wisconsin-Madison
Biomedical Engineering Design 200/300
December 12, 2018

Clients:

Dr. Rita Deering

College of Health Sciences: Physical Therapy at Marquette University

Dr. Bryan Heiderscheit

UW-Madison Health Sports Rehabilitation Physical Therapy

Advisor: Dr. Wan-Ju Li

Department of Biomedical Engineering

Team members:

Samuel Parmentier (Team Leader)

Daniel Wildner (BWIG)

Noah Nicol (Communicator)

Kaitlin Lacy (BPEG)

Brittany Glaeser (BSAC)

Abstract

It is common for women to experience conditions related to pelvic instability during and after pregnancy. This can lead to pain and irritation in daily life that could last years. More seriously, it can lead to lower extremity weakness that can lead to further damage to the muscles, bones, and even organs. Dr. Bryan Heiderscheit and Dr. Rita Deering intend to determine if this condition can be assessed by measuring the maximum voluntary contraction (MVC) of the lower extremities of a postpartum female performing a straight leg raise. They will then compare it to the MVC produced by an adult female who has never been pregnant. The two have been able to confirm that there is a correlation between pelvic instability and pregnancy, but have not been able to quantify their findings and need a device that can interface with the computers in their lab to accurately measure the MVC of a postpartum adult female performing the prescribed task. The LEST (Lower Extremity Strength Tester) is an apparatus developed specifically for this task. It includes load cells fixed into upright supports of the frame that records the forces of the subject's MVC as a strict testing method developed by the two doctors is followed. By using the LEST, Dr. Heiderscheit and Dr. Deering hope to quantitatively measure the effect of pregnancy on lower extremity strength to create set points that can be looked upon in future clinical settings to determine if a subject is experiencing pelvic instability, and if so, to what degree.

<u>Table of Contents</u>	<u>Page(s)</u>
Abstract	1
Table of Contents	2-3
I. Introduction	4-5
A. Motivation	4
B. Problem Statement	4-5
II. Background	5-9
A. Team Research	5
B. Anthropometric Data	6-8
C. Client Research Results	8
D. Design Specifications	8-9
III. Preliminary Designs	9-11
A. The Jungle Gym	9-10
B. The Box	10
C. The Rubber Hose	10-11
IV. Preliminary Design Evaluation	11-15
A. Design Matrix	11-12
B. Justification of Criteria and Weight	12-13
C. Initial Proposed Final Design	13-15
V. Fabrication/Development Process	15-26
A. Materials	15
B. Fabrication Methods	15-16
C. Final Design	16-20
D. Electronics	20-25
E. Planned Testing	25-26
VI. Discussion	26
VII. Conclusion	26-27

- A. Future Work 26-27
- VIII. References 28-29
- IX. Appendix 30-44
 - A. PDS 30-34
 - B. Materials List 34
 - C. Fabrication Methods 35-39
 - D. Arduino Code 39
 - E. CAD Drawings 40-44

I. Introduction

A. Motivation

Following childbirth, postpartum women experience a loss of muscle strength in the hip flexors (iliopsoas) and knee extensors (rectus femoris, quadriceps). This is due to the constant increased pressure on the muscles during pregnancy, thus causing abnormal stretching. These muscles also have an increased rate of fatigability. Frequently, women are often dismissed when describing these pains. Some women are unable to walk for an extended period of time after pregnancy due to their weakened pelvic stability. This is a serious problem that goes untreated and could result in permanent loss of muscle strength. Women undergo many physiological changes during pregnancy and afterwards; their abdominal muscles exert an increased stretch and inter-recti distance. They also have hormones that influence the connective tissues, thus causing joint laxity [1]. Joint laxity is considered the looseness or instability of the joint [2]. Furthermore, the woman loses passive lumbopelvic joint stabilization. This causes muscular stabilization from the abdominal muscles to overcome this loss [1]. This common problem in women is not researched extensively and more data is required. As a result, a device needs to be created to help collect force data from these muscularly impaired women. The LEST device is designed to quantitatively measure the force applied by the subject in the positive and negative z directions as accurately as possible. By accurately collecting data from the force applied from the subjects post-fatiguing task, more data can be collected to help understand this recurring problem. With no other competing designs, the product will not have any comparisons to products currently in market. In addition, while not its main purpose, it can be used to test muscle strength for other types of rehabilitation. Some additional areas it may be useful for include ACL reconstruction, knee replacement, and hip and abdominal surgery. This is because the device can directly or indirectly measure muscle groups in each of these procedures. If subjects change their body position, the device can also measure strength of the hamstring, gluteus maximus, other hip flexors, rectus abdominis, obliquus externus, and rectus femoris [3]. While it has the capabilities to measure a great number of muscle groups, the main purpose of the device is for research on the pelvic floor muscles of postpartum women.

B. Problem Statement

During and after pregnancy, it is common for women to experience a loss of strength in the muscles of the pelvic girdle. This can cause serious pain and discomfort, and new methods are continually being researched to relieve women of this condition during their already challenging pregnancy. A device is needed to assess a maximal voluntary contraction (MVC) of the hip flexor (iliopsoas) and knee extensor (quadriceps, rectus femoris) muscles during a straight leg raise task to assess the loss of strength. This can be a sign of pelvic instability in the lower extremities of women both during and after pregnancy. The subject will first perform a fatiguing task with one leg inside of the apparatus while the other leg presses down on the push plate of the device. The push plate will be raised and the fatigued leg will perform a straight leg raise against the push plate, thus measuring the MVC. By initially performing a fatiguing task, the affected patient will most likely experience an increased rate of fatigability and greater

hip flexor and knee extensor muscle weakness. By quantifying the force data generated from these fatigued muscles, our client can proceed to make conclusions on how to proceed with this common problem.

II. Background

A. Team Research

Pregnancy and childbirth create physical stress in many areas of the body. As the fetus grows, the abdominal muscles separate in order to allow the womb to protrude and weight distribution of the mother is altered. The physiological changes of childbirth due to the stress of delivery contribute to weakened postpartum pelvic floor muscles. Pelvic floor muscles consist of multiple layers of musculature between the tailbone and sacroiliac joint. The purpose of the sacroiliac joint is to connect the spine to the pelvis [4]. These muscles contribute to sphincter closure and sexual function, as well as the function of supporting the spine, bladder, and internal organs. As a result, weakened pelvic floor muscles are associated with higher chances of pelvic organ prolapse; an occurrence in which internal organs “fall” to a lower location in the abdomen due to lack of support [5].

Pelvic bowl muscles (along with ligaments and other tissue) support the sacrum and ilium bones of the pelvis. When these muscles are weakened from childbirth, they distribute forces to unsuitable areas, thus increasing the chance of injury not only in the hip area, but also in the knees or ankles [4]. Evidence that pelvic muscles bear relevance to other parts of the body is clear through studies of the Active Straight Leg Raise test (ASLR) in which the test has been shown to transfer loads between the legs and lumbosacral spine [6]. The test is simply performed by raising one fully extended leg while in the supine position.

For Dr. Deering’s study, participants will be asked to lie on their backs and perform a straight leg raise while their MVC (Maximum Voluntary Contraction) of the hip-flexors/knee-extensors is measured. During this motion, the hip flexor, as well as the rectus femoris, sartorius, and tensor fasciae contribute to the motion of raising the leg. The knee extensor muscles (quadriceps and rectus femoris) contribute to stabilizing the leg [7]. For a detailed description of the testing process, see the testing procedure portion of the appendix.

To obtain an optimal design for the client, a few guidelines were followed. The device needed to be able to move between locations; therefore, our device needed to be light, easy to assemble, and easy to store. Also, the device had to be able to withstand the strength of an adult women who will be applying an upward force against the push plate.

During the test, the patients will need to perform a fatiguing task, and soon after, their MVC will be measured. Thus, the device will need to be set in place within 60 seconds after the fatiguing task. Since the patients are using all their leg force on the device, it is necessary that the push plate (where the patient’s ankle applies pressure) is soft enough to not cause them any pain. A complete list of product design specifications can be found in the Appendix, section 1- PDS.

B. Anthropometric Calculations

There are a few important dimensions that were taken into consideration for the dimensions of the LEST design. The dimension of utmost importance was the height of the push plate. The average ankle circumference of an adult female is 20.14 cm [8] and the average width is 4.7 cm [9]. Using this information, the equation for the perimeter of an ellipse was used to determine the length of the ellipse (distance from the front to the back of the ankle, above the foot). The calculations for this value are as follows:

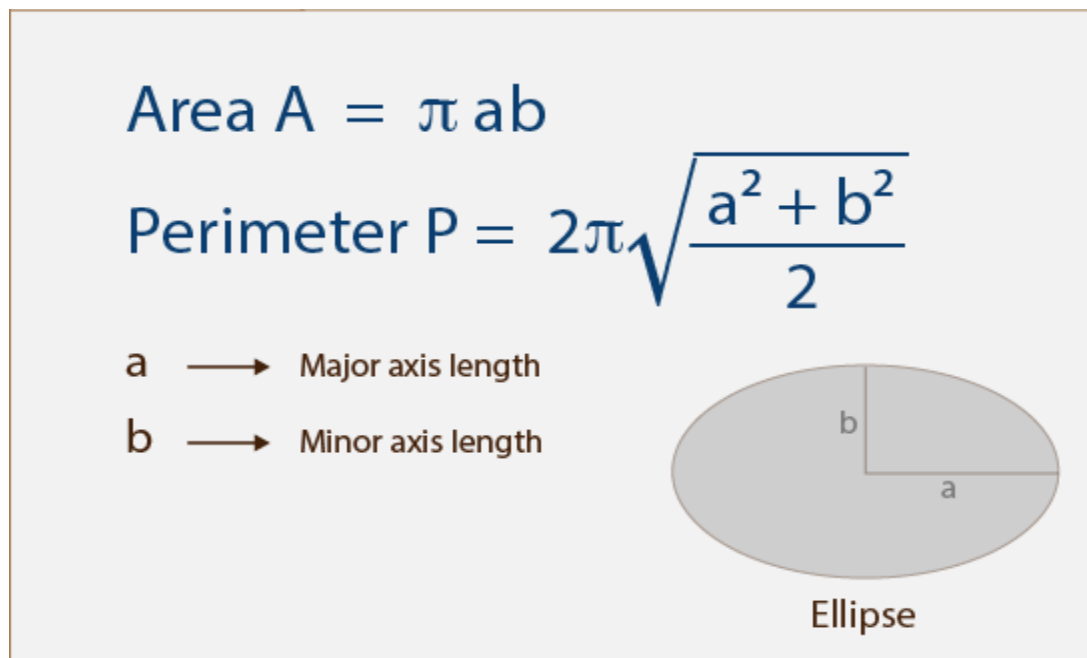

Image 1: Equations for the perimeter of an ellipse.

$$\text{Known : } P = 20.14 \text{ cm}$$

$$b = 4.7 \text{ cm} / 2 = 2.35 \text{ cm}$$

$$\begin{aligned} a &= \sqrt{2 * (P/2\pi)^2 - b^2} \\ &= \sqrt{2 * (20.14/2\pi)^2 - 2.35^2} \\ &= 3.88 \text{ cm} \end{aligned}$$

$$\text{Therefore, the distance from back to front of ankle} = 2 * a = 7.768 \text{ cm}$$

This dimension is important because the push plate will need to be at least this far from the base plate to allow the ankle to fit in between the two. However, this distance should not be much greater than the value of the average ankle height, as the forces produced by the lower extremity MVC should be as vertical as possible to ensure their accurate recording. Based on the previous math, the push plate needs to be at least 7.768 cm above the ground. Additionally, a few centimeters need to be added so the subject

can easily move their foot and ankle underneath the push plate. To account for different ankle sizes, the push plate needs to be adjustable so the desired height can be obtained.

Three additional anthropometric values also needed to be considered. First among them is the average distance from the ground to the hip of the adult female. This distance is important because the base plate will have a hinge relatively in the center of it, but the exact location needs to be modified so that the subject's rear will be exerting a downward pressure on the same piece of the base that the push plate assembly is fixed to, using the weight of the subject as a downward force to hold the entire assembly against the ground while they push upwards against the push plate. Next, the distance from the base of the foot to the ankle of the subject has to be considered so that the push plate assembly can be fixed a proper distance from the end of the base plate, ensuring that the top of the subject's ankle comes into contact with the push plate and maximum comfort is achieved. Finally, the average hip width of adult females needs to be considered in order to make the width of the base plate and the distance between the vertical supports of the push plate assembly a proper distance apart in order for the subject to comfortably situate themselves within the design.

The calculations for the three previously described measurements utilized the average height of the adult American female listed in the CDC's Anthropometric Reference Data [10] of 63.7" and a figure of average body segments lengths based on height fraction [11], shown below:

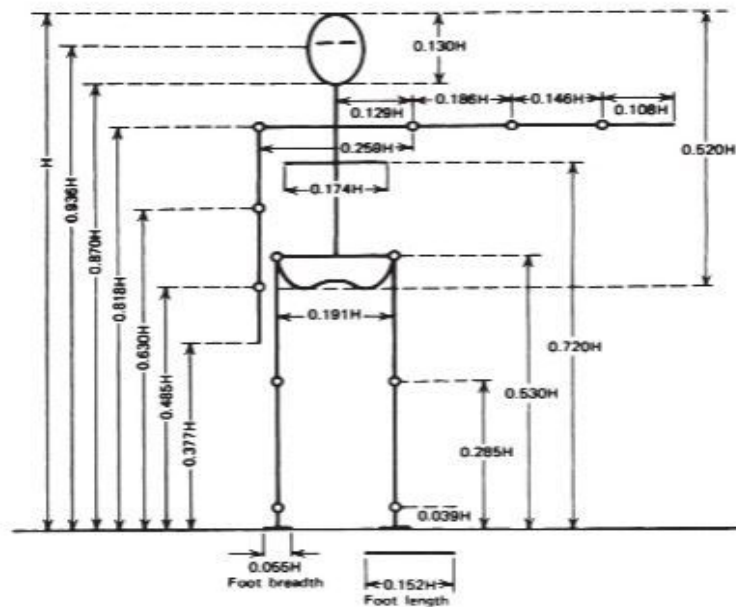

Image 2: Average body segment length based on individual subject height.

Using the values seen in this figure and the average adult American female height of 63.7", the values can be calculated as follows:

Hip Height:

$$63.7'' \times .53 = 33.76''$$

Hip Width:

$$63.7'' * .191 = 12.16''$$

Ankle Height:

$$63.7'' * .039 = 2.48''$$

Knowing the values of these measurements, the apparatus can be appropriately sized in order to accommodate the average adult American female +20% to allow for variance in body size. Therefore, the length of the base plate that the subject will have their lower body on should be at least 40'', the width of the base plate should be at least 16'', and the distance from the end of the base plate to the center of the push plate apparatus should be at least 3''. These anthropometric calculations do not account for body composition which is difficult to calculate quantitatively.

C. Client Research Results

Dr. Rita Deering has quantitatively researched the correlation between the Active Straight Leg Raise and pelvic instability. The LEST team has included this research and its findings here as they provide additional background information.

Dr. Deering, along with fellow researchers, used the Active Straight Leg Raise to assess the stability of the lumbopelvic muscles. Comparing the results of women up to twenty-six months postpartum with women who had never been pregnant allowed them to explore the effects of pregnancy on the lumbopelvic muscles. Postpartum women often experience pain in the lower back and pelvic girdle which could be a result of this loss of stability.

All of the women used in the study were free of other health problems that could have impacted the results of the test. Postpartum women completed their first test eight to ten weeks after delivery and their second test 24 to 26 weeks after delivery. Test subjects had to raise their leg twenty centimeters and hold for five seconds before lowering their leg. They then rated the difficulty of that task on a scale of zero to five with zero being not difficult at all and five being unable to lift their leg. Pressure was applied to the region if the score reported was higher than a zero. The straight leg raise is then repeated with the applied pressure and if the difficulty decreased, then lumbopelvic instability was reported. Then participants performed the active straight leg fatigue test in which their leg was raised to twenty centimeters and held. Failure occurred when an air bladder under their lower back changed pressure by twenty or more mmHg or their leg dropped below ten centimeters. Initially, 23% of the control and 37% of postpartum women tested positive for instability. Later tests reported 12.5% and 44% respectively. The fatiguing task showed a faster failure time for postpartum women than the control groups. No significant difference was found between the time to failure of those testing positive for active straight leg initial test and those who tested negative [1].

D. Design Specifications

From the findings of the researchers at Marquette University, it was found that postpartum women often test positive for pelvic instability. The data from their research was all qualitative and differed between tests. An issue with this data is that the results vary. One way to develop more accurate

and consistent results would be to produce quantitative data. The Lower Extremity Strength Testing device generates numerical results that can be used to determine instability. The LEST allows women to press upward (7-12 cm off the ground) into a push plate that measures their force. This force can be analyzed to determine the maximum voluntary contraction (MVC) of the hip flexor muscles.

For the device, there are sources of error that will need to be taken into consideration. One important factor is recovery time. It was required that the patient is able to quickly position themselves in the device and perform the task as quickly as possible. The longer it takes for the subject to position themselves, the more time the muscles have to recover before the MVC. Additionally, since the device is secured to a somewhat flexible HDPE sheet, if enough force is applied, the sheet has the capability to bend. There are simple procedural measures that can be taken to mitigate this effect. Either the heel of the straightened, non-tested leg must be in contact and pressing down into the HDPE sheet or the non-tested leg can be bent. Both of these methods provide enough downward force to counteract the upward force of the straight leg raise and prevent significant bending of the HDPE sheet. Additionally, the test administrator could stand on the back of the design, preventing it from flexing upwards. Negligible amount of bending may still occur, however this is not a concern because it should not affect accuracy of measurement and a small amount of flexion will still provide enough resistance so that patients can exert their MVC.

Our clients had certain design specifications for our project in order to fit their research standards. The device must be able to function in multiple settings as the testing locations will vary with their research. Also the device must be able to sustain a maximum effort from an adult female (proved in image 8). The device must accurately obtain the appropriate force data as well as provide substantial room for the fatiguing task prior to maximum voluntary contraction. All design specifications are further explained in the Appendix (PDS section I).

III. Preliminary Designs -

After considerable research and collaboration with Dr. Deering on the testing procedure, the LEST team developed three feasible design alternatives.

A. The Jungle Gym

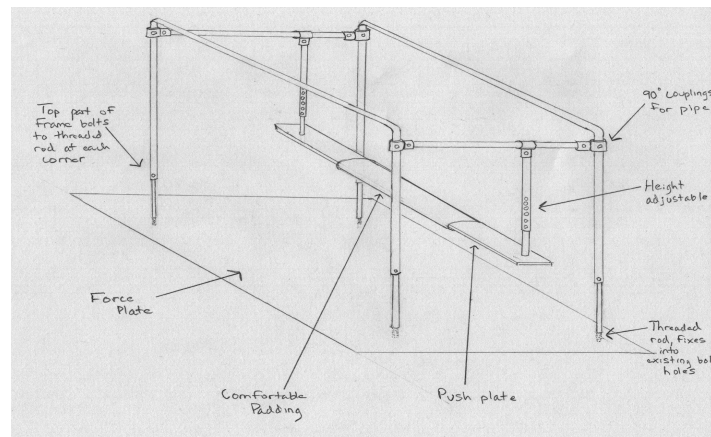

Image 3: The Jungle Gym design idea.

The Jungle Gym design is comprised of a simple frame network that consists of varying sizes of aluminum tubing and a push plate that hangs in the middle of the network that provides an ideal surface for the participant to push against. There are four corner posts with threaded ends that fix directly into the bolt holes of the force plate. Then, the rest of the frame assembly can be set upon the corner posts and pinned in place. All pieces are fixed together with 90 degree tube couplings and will be bolted in place to them. The push plate will hang down from vertical supports and will be fixed to a piece that is smaller in diameter than the inner diameter of the support tube, allowing for the push plate to be height adjustable.

B. The Box

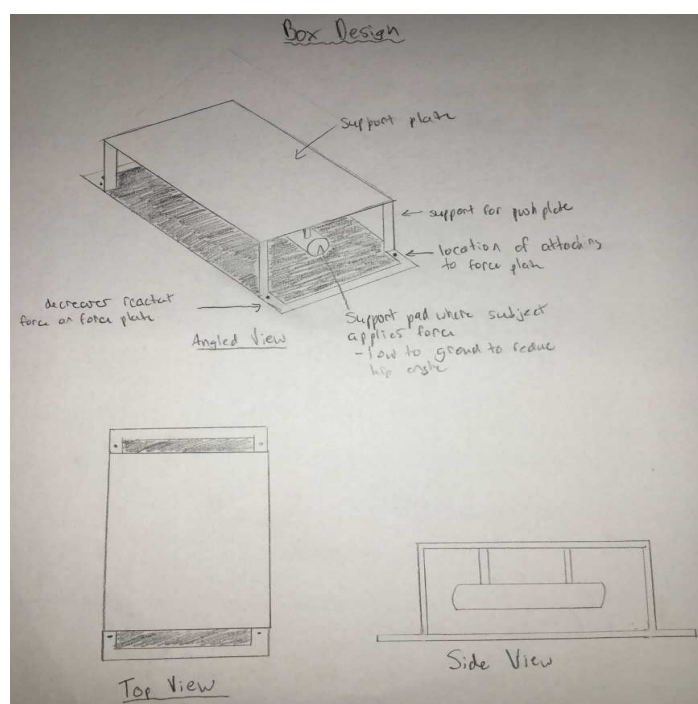

Image 4: The Box design idea

The Box design features a plate that rests on top of four corner supports. These supports have a “foot” at the bottom that is perpendicular to the vertical portion of the support, and each foot has a hole drilled through it for a bolt to fix into the existing bolt holes of the force plates. A padded bar hangs down from the top plate and provides a surface for the subject to apply force against. This bar is relatively low, ensuring that the force created by the subject is as close to vertical as possible. This will aid in ensuring the accuracy of the data collected during testing.

C. The Rubber Hose

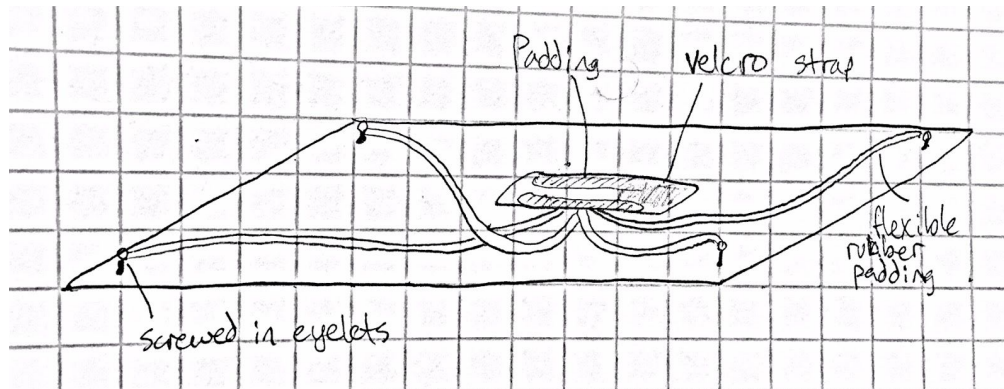

Image 5: The Rubber Hose design idea

The Rubber Hose design idea features four lengths of hose that are tied onto eyelets screwed into the four existing bolt holes in the force plate on one end. At the other end, each length of rubber hose fixes to a leather harness with a velcro strap that will fix directly to the ankle of the subject during testing.

IV. Preliminary Design Evaluation

A. Design Matrix

Design	Design One - Jungle Gym	Design Two - The Box	Design 3 - Rubber Hose
Criteria			
Ability to Accurately Measure MVC (30)	5/5 30	4/5 24	2/5 12
Quickness of data collection after fatiguing task (25)	4/5 20	4/5 20	5/5 25
User Comfort (15)	4/5 12	4/5 12	4/5 12
Ease of Fabrication/Assembly (15)	3/5 9	3/5 9	5/5 15
Aesthetics (5)	5/5 5	4/5 4	1/5 1

Cost (5)	3/ 5 3	3/ 5 3	5/5 5
Safety (5)	5/5 5	5/5 5	3/ 5 3
Total (100)	84	77	73

Figure 1: The LEST design matrix, showing overall scores for the three proposed designs.

B. Justification of Criteria and Weight

Ability to accurately measure MVC-

Accuracy received the highest weight distribution because the effective functioning of the design is of the utmost importance. This design will be used in actual research that will be published by university faculty; therefore, it must have a high degree of accuracy to ensure the validity of the results of the research. The Jungle Gym design scored highest (5/5) because it is fixed vertically to the force plate. The Box, in contrast, was fixed with bars flushed with the force plate. These bars could transfer non-vertical force from one support to another or torque into the force plate. The Rubber Hose design allowed for forces in the x-axis and y-axis that will disrupt the accuracy of the z-axis data.

Quickness of Data Collection After Fatiguing Task-

It is imperative that the MVC of the subject is able to be recorded quickly after completing the fatiguing task to prevent their muscles from recovering and skewing the data. Additionally, the patient should easily be able to place their legs within the device without struggle. The Rubber Hose scored the highest in this category because it will be fixed to the subject during the duration of the test, whereas the subject will have to move their leg into contact with some surface of the other two designs to initiate data recording.

User Comfort-

As a patient's MVC is being measured, they should not endure any pain that could affect their results. This would likely be encountered between the surface that comes into contact with the ankles, where the MVC is measured. This surface should not be so hard that it causes discomfort, but should also not be so soft that it absorbs the force of the MVC and skews the data. Each of the designs received the same score in comfort because each design incorporated padding to allow the subjects to be comfortable while performing the straight leg lift.

Ease of Fabrication/Assembly-

Fabrication of the design should be completely within our ability. Also, the device needs to easily attach to the force plate in a manner that any administrator of the task can easily remove the device for transport to different facilities. The Rubber Hose scored the highest because it didn't require a lot of material, and nothing that needed to be built together. As for assembly, the only assembly required would be to screw into the holes on the plates and a velcro strap for the patient's ankle.

Aesthetics-

Aesthetics received one of the lowest weighted criterias due to it not having any impact on the patient's well-being or the results from the device. However, the final design should still look professional, as it will be used in professional research. The jungle gym was scored the highest in this category because it is not as bulky as The Box design.

Cost-

The client offered a budget of 1000\$ and this will be extremely sufficient for any design. For this reason, the weight of the cost category was lower. None of the designs should reach this overall cost, but the rubber hose obviously features the fewest and the most simple materials, so it scored the highest in this category.

Safety-

The safety of the client and the test subject is an important aspect of any design. It is assumed that any design considered will meet a certain standard of safety. The design will likely be stationary and will not in any way alter the subject, so there are not many safety concerns involved. The Box and the Jungle Gym design scored the highest in this category because the subject's movements are relatively constrained, whereas the Rubber Hose design would allow for the subject's lower body to move in all directions, which presents an inherent safety concern.

C. Initially Proposed Final Design:

The jungle gym received the highest score overall. Its accuracy and speed of data collection, aesthetics, and patient comfort were some of the highlights of the design. However, after further team discussion, it was realized that some features were still missing despite it's high scoring. They include:

- A feature that allows the push plate to “fold up” so that it can be moved out of the way while the subject performs their fatiguing task.
- A rest for the foot that isn't recording an MVC so that it doesn't push against the force plate and disrupt the accuracy of data collection.

After adding these components to the existing Jungle Gym design, the final design was completed and appears as follows:

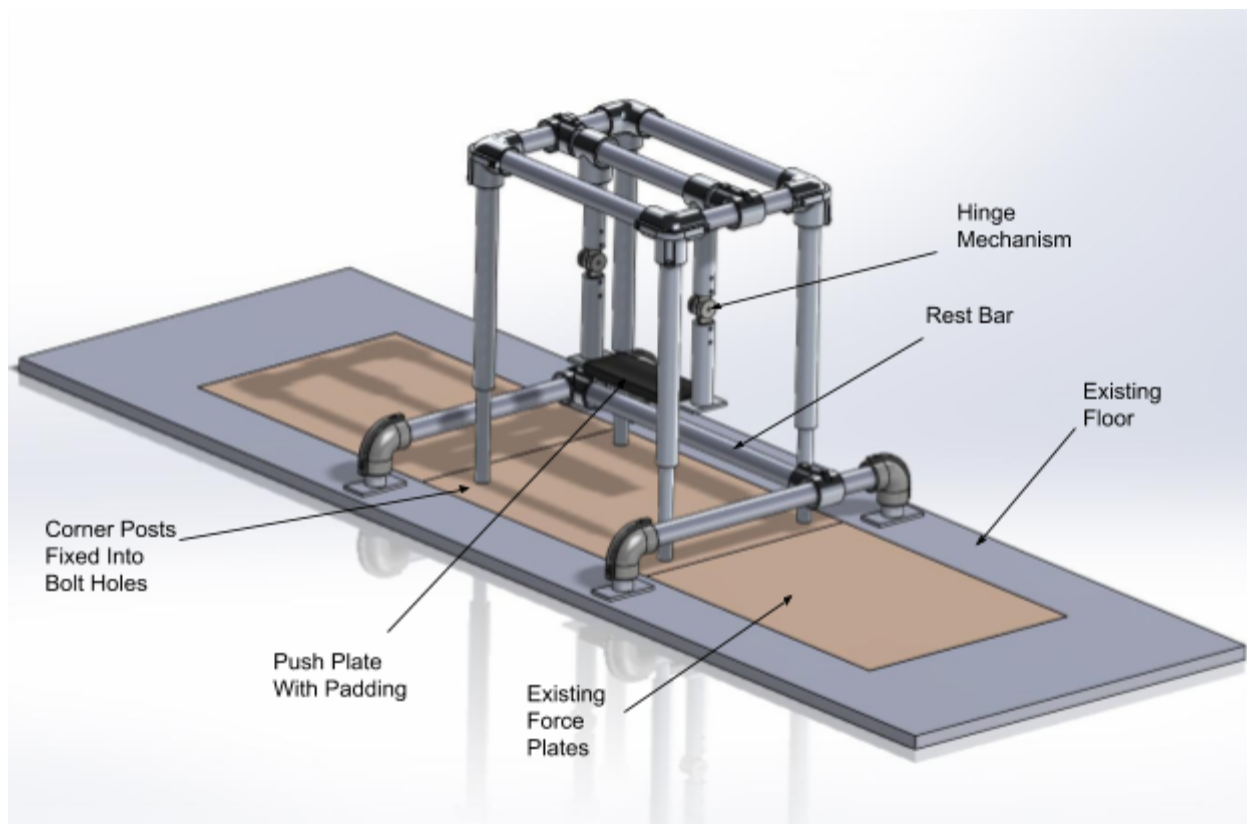

Image 6: Isometric view of the proposed final design.

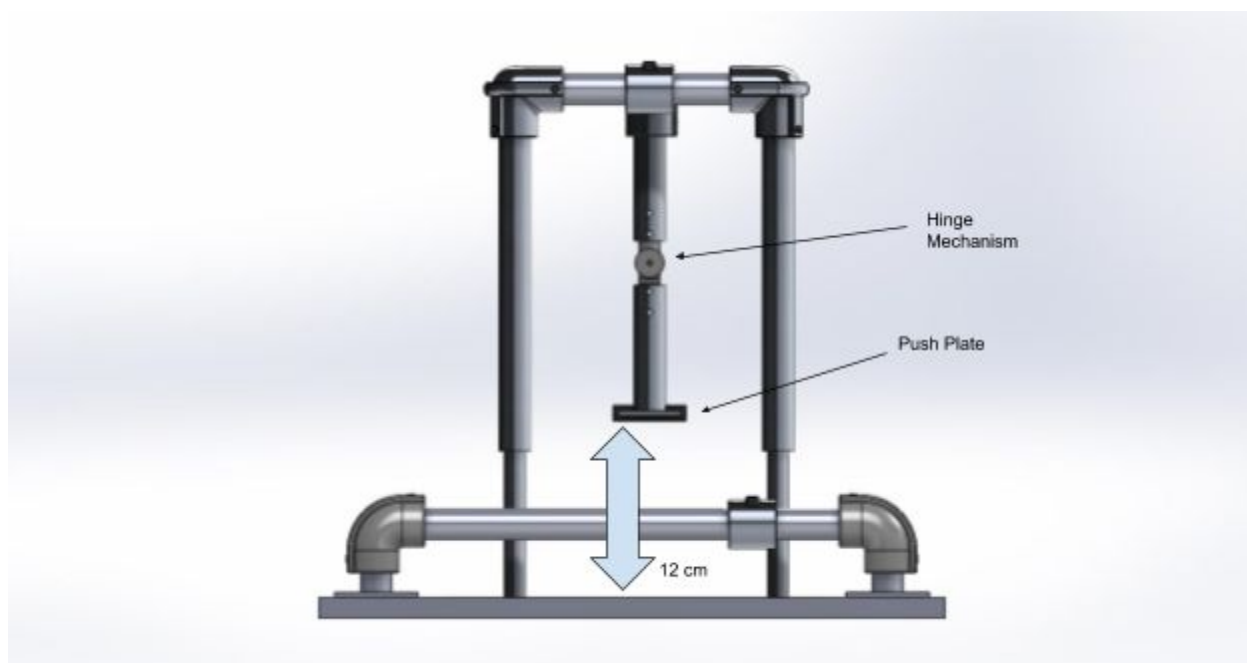

Image 7: Right side view of the proposed final design.

This design is much like the original Jungle Gym, but it includes the two main features that were listed above. A hinge mechanism that is adjustable when a button is pushed will be placed between the two vertical pieces that support the push plate. Additionally, a rest bar has been added to support the foot not producing an MVC during testing. As can be seen in the image above, this assembly is entirely separate from the Jungle Gym apparatus and does not in any way come into contact with the force plates. This is because any downward pressure on the force plate from the foot and leg not in use would disrupt the accuracy of the data generated by the MVC of the other leg. This would have been an issue if the rest bar were attached to the Jungle Gym.

V. Fabrication/Development Process -

A. Materials

For this project, the frame consists entirely of solid aluminum bar. Everything is fixed together with variously shaped connecting joints, which hold the frame pieces in place with set screws. The push plate is made out of an aluminum bar. The corner towers are also made out of aluminum bar and feature two handles with a threaded stud to allow the push plate to be raised and lowered. All of this is fixed to a sheet of high density polyethylene (HDPE) with a recycled yoga mat for padding on top. The HDPE sheet is cut into two pieces with three brass hinges on the bottom half to allow for folding and easier portability. Load cells are implemented into the uprights of the frame and these measure the forces in both tension and compression. A detailed list of the materials used for this project and their cost can be found in the Appendix, section B- Materials List.

Aluminum 6061 1 in diameter

$E = 10 \times 10^9 \text{ Pa}$
 $G = 3.5 \times 10^9 \text{ Pa}$
 $G_u = 30 \times 10^6 \text{ Pa}$

$A = \pi r^2 = \pi (0.0127 \text{ m})^2$
 $d = 1 \text{ in}$
 $r = 0.5 \text{ in} = 0.0127 \text{ m}$

$G = \frac{F}{A} \Rightarrow G_u = \frac{R_A}{A_1} + \frac{R_B}{A_2} \Rightarrow 30 \times 10^6 \text{ Pa} = \frac{F}{2A} + \frac{F}{2A} \Rightarrow 30 \times 10^6 \text{ Pa} = \frac{2F}{2A}$

$A_1 = A_2 = A$

$15201.224 \text{ N} = 3417.3711 \text{ lb-f}$
 \therefore sturdy enough material

$F_{max} = 15201.224 \text{ N}$

HDPE
 $G_u = 15.2 \times 10^6 \text{ Pa}$

$G_u = \frac{F}{2A} + \frac{F}{2A} = \frac{F}{A} \Rightarrow 15.2 \times 10^6 \text{ Pa} (0.1778 \text{ m})(0.0127 \text{ m}) = F_{max}$
 $F_{max} = 34322.512 \text{ N}$
 $= 7716.01 \text{ lb-f}$

cross-section
 7 in
 1.5 in
 $7 \text{ in} = 0.1778 \text{ m}$
 $1.5 \text{ in} = 0.0127 \text{ m}$
 $A = (0.1778 \text{ m})(0.0127 \text{ m})$

Image 8: Calculations showing maximum force(lbs-f) that can be exerted on the aluminum bar and HDPE

Image 8 depicts the calculations required for the two materials that would experience the most loading during testing. The aluminum bar in the above portion of the calculations will experience the direct force applied from the test subject. By looking up the mechanical properties of the 6061 aluminum bar and finding the maximum stress that can be applied, the maximum force without deformation was calculated. A similar process was done to determine the maximum force applied to the HDPE. While the aluminum bar should have a much larger tolerance for force applied, it had a relatively small cross-section in comparison to the portion of HDPE.

B. Fabrication Methods

The aluminum rounds and bars came in long lengths that were cut to a rough length, faced or milled off to finished length, and had their edges broken. The vertical supports for the push plate had a threaded hole on one end to allow for it and the push plate, which had two through holes drilled through it to be fixed together with bolts. The vertical supports on each side of the load cells had their diameter turned down and threaded on one end to create a threaded stud that could mate directly to threaded holes in each side of the load cells. The corner towers underwent extensive modification, including drilling a 1" through hole completely through their length, milling a relief cut on one end to enable clamping of the vertical supports within the corner tower, creating threaded holes on each side of the center hole to provide for this clamping force via the use of a threaded handle, drilling four holes on the base to fix the towers to the HDPE base plate, and milling down one face of the tower to increase the flexural ability of the material on that side of the relief cut. The HDPE base plate consisted of two pieces. Each had three pockets milled on one edge to fit brass hinges into them so that the plate could lay flat on the ground without the hinges "bumping" it upwards. Holes were drilled and threaded in these pockets to fix the hinges in place. Additionally, the part of the base plate that the lower body of the subject would be laying on was wider on one end to allow for the fixture of the corner towers to it. At the wider end, four clearance holes were drilled matching the hole pattern of the holes drilled and threaded in the bottom of the corner towers to allow for the two parts to be fixed together. The holes on the bottom face of the base plate were also countersunk to accommodate ¼"-20 flat head screws, again so that the base plate could lay flat on the ground. After completing all of the necessary modifications to the ordered materials, the individual parts were assembled using the connecting joints as depicted in the images in the Final Design Section. A complete, detailed list of all of the fabrication processes needed to fabricate the LEST apparatus can be found in the Appendix, section C- Fabrication Methods.

C. Final Design

The final design that was physically reproduced as a prototype can be seen below. As is evident, this final design is very different from the initially proposed design. This is because further discussion with Dr. Deering and Dr. Heiderscheit revealed that they wanted the apparatus to be fully portable for usage in numerous clinical settings, rather than it being designed to fix directly to the force plate setup currently used at the UW-Health Research Park setting as was initially understood. The design consists of a metal structure attached to a piece of HDPE, which has a yoga mat on top for comfort. The base is cut in half and joined by hinges to allow for folding of the device. This allows for increased portability and

easier storage. Several dado cuts on the bottom of the HDPE sheet run parallel to the longer edge in order to reduce the total weight. Two corner support towers have through holes for the aluminum tubing that attach to the push plate. These holes were reamed to be slightly above the diameter of the aluminum vertical supports to allow for them to move up and down within the corner towers. A relief cut is made on either side of the through hole, and there are two threaded holes on the side face of the tower. By tightening handles of an appropriate thread size and length, the two halves of material on each side of the relief cut can be “clamped” together, holding the vertical supports in place. In this way, tightening and loosening the handles allows for the height of the vertical supports (and more importantly the push plate) to be easily adjusted. Load cells are also incorporated into the upright supports. Essentially, each full vertical support was cut in two pieces and one end of each piece had its diameter turned down and was threaded. In this way, each part of the vertical support could thread directly into the threaded holes on each face of the load cell. Because the vertical supports are rigidly attached to the push plate, any force exerted upon the push plate will be equivalently recognized by the load cells in the vertical supports. When the foot not being fatigued in the initial portion of the testing procedure is resting on the push plate, its force will be recognized in compression. When the fatigued leg is pushing up against the bottom of the push plate with its MVC, the force in the apparatus will be recognized by the load cells in tension. A 3D model of the design and several images of the completed prototype can be seen below:

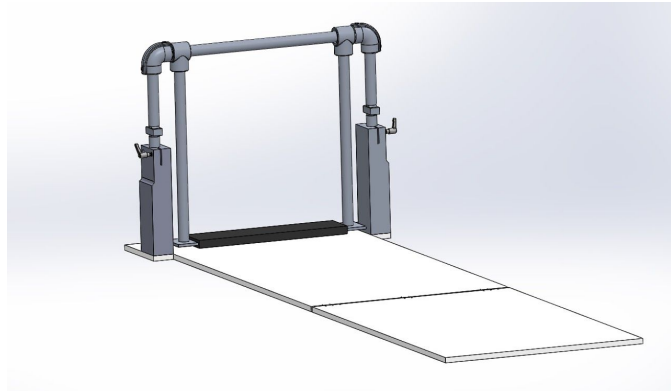

Image 9: Solidworks rendering of final prototype.



Image 10: An isometric view of the completed prototype.

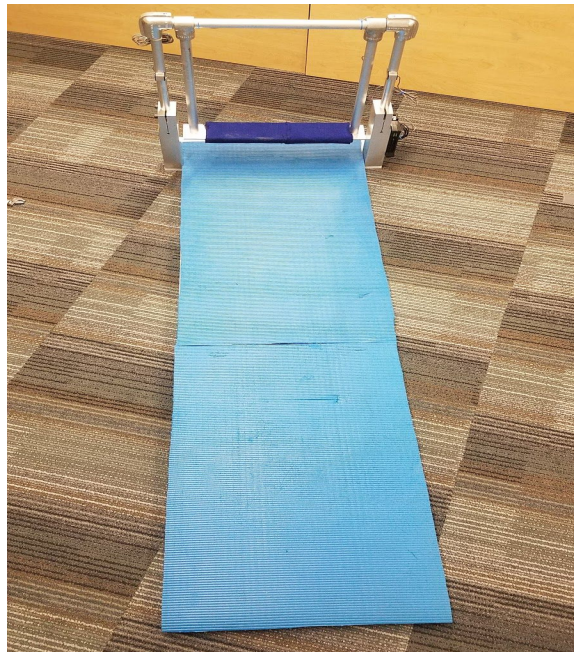

Image 11: A top view of the completed prototype.



Image 12: A closeup isometric view of the completed prototype, featuring the push plate apparatus.



Image 13: A closeup isometric view of the completed prototype, featuring the SST setup on the right side.



Image 14: A bottom view of the completed prototype, featuring the base plates and the dado cuts that were made into them to reduce their overall weight. Also shown are the affixed hinges and the milled pockets made to accommodate them.

Many of the features described in the final design section can be seen in the images above, including the modifications made to the base plates, the corner towers, and some of the electronics setup that will be described below. The only item not shown in the 3D model is the added yoga mat.

D. Electronics

In order to record the forces recognized by the load cells, a complex electrical setup was used. The general flowchart for the electrical setup can be seen below:

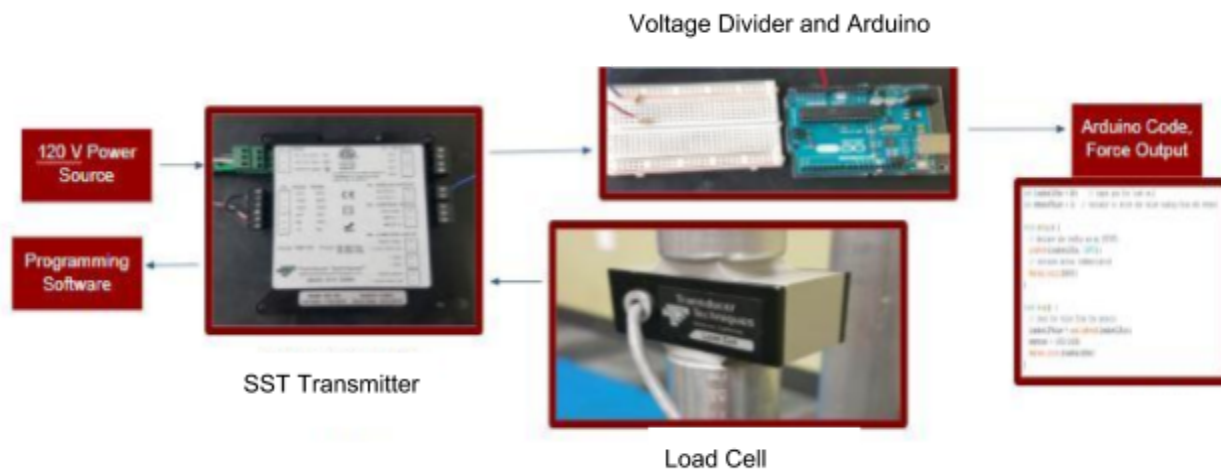

Image 15: Flowchart progression for the electronics setup.

To begin, a force is first exerted upon the push plate of the design. As described previously, this force is then recognized by each load cell, which both are rated for a capacity of 300 N. The wires

coming out of the load cells are then connected to the SST High Voltage Load Cell Transmitter, which acts as a “middle man” between the load cell and a signal processor. The transmitter is powered by a basic 120 V power source and is programmed using software downloadable from transducertechniques.com, which is the company the load cells were purchased from. The wiring of the load cells and how they properly interface with the SST Transmitter can be seen below:

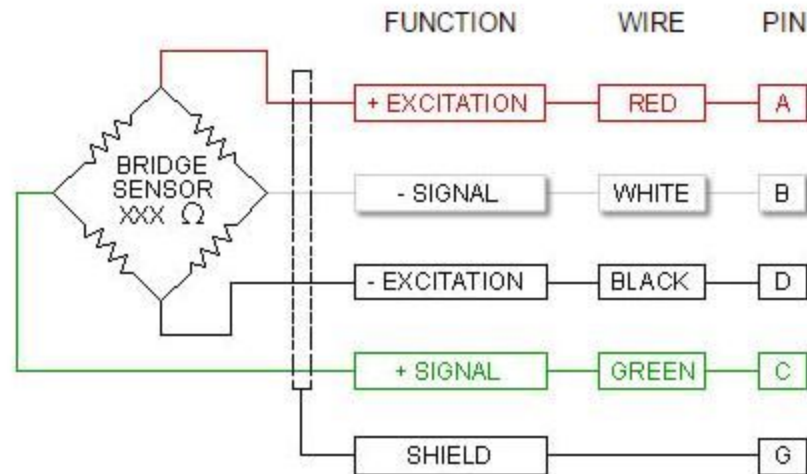

Image 16: Wiring diagram for the MLP-300 Load Cell used in this design [12].

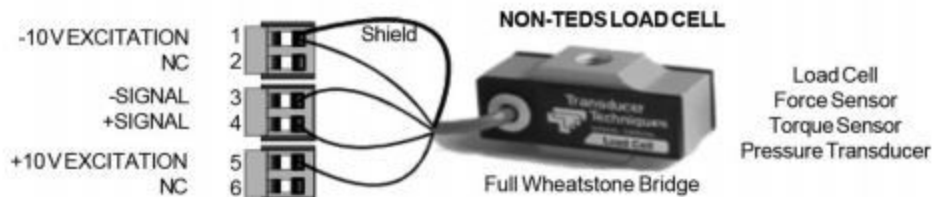

Image 17: Wiring diagram detailing how the wires described in image 16 interface with the SST transmitter [13].

The SST transmitter features a wheatstone bridge inside of it, with the unknown resistance input to one side of the bridge being the input from the load cell. In this way, the input from the load cell can be measured based on the overall output from the wheatstone bridge. This overall output from the bridge is also the output from the analog terminal of the SST, which will be integrated with additional components of the electrical design later on in the explanation. One issue with the SST is that it is only designed to take the input from one load cell. However, two load cells were used in this design. In order to work around this, like wires from each load cell were wired together along with one end of a third wire inside of a wire nut. Then, the opposite end of the third wire from each combined pairs of wire from the two load cells was hard wired into the appropriate terminal on the SST, as depicted in image 12. As a result of doing this, the effective capacity of the load cells was now 600 N. The output of the SST Transmitter had to be modified in the initial programming software to reflect an average of the two inputs from 0-300 N from the load cells, rather than a sum of their inputs ranging from 0-600 N. This will be detailed further below.

An RS-232 “9-Pin” serial cable was what provided the connection between the SST transmitter and the computer the software program was installed on. One end of the RS-232 cable was hard wired directly into terminals on the SST board, shown below:

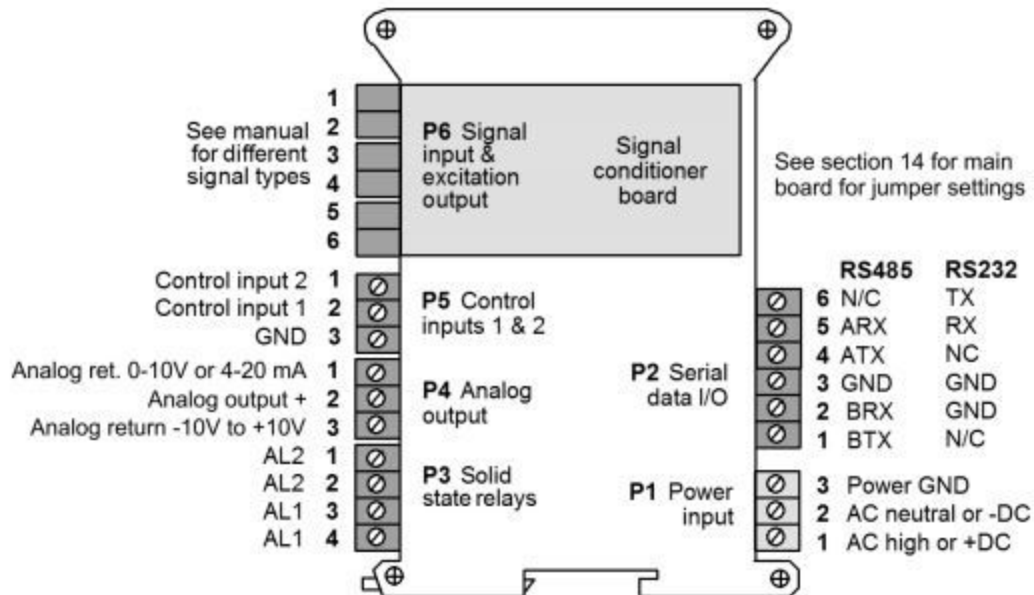

Image 18: Wiring diagram detailing how all of the terminal designations for the SST transmitter [13].

The correct connection to the terminals for the RS-232 cable are detailed in the “P2” section of the image. As can be seen, the “P6” section is what the load cells wire into. The “P4” section is where the output from the SST can be obtained. One wire was attached to the number two terminal in this section, and its destination will be discussed later on in the electrical wiring explanation. The “P1” section was dedicated to providing power to the SST and load cells from a 120 V power source. The power cable for the SST was included with the device and could interface directly with the terminals. The “P5” and “P3” sections were unused. The opposite end of the RS-232 cable was connected with a serial-USB adapter, as the laptop used for the electronics did not have a serial port.

After connections between the SST and the programming software were established, settings within the software were changed to ensure that the SST output would be appropriate based on the type of testing being performed. The first step was to establish communications within the software. The connection type (RS-232) had to be selected, and the appropriate communications port that the serial-USB adapter was connected to had to be configured. After establishing a connection, various settings were able to be adjusted. Within the “scaling” window, the low and high input values had to be set based on the range of input values the SST would be receiving from the load cell. Additionally, the low read and high read values had to be programmed so that the output of the SST would be appropriate. Next, the communication settings had to be adjusted. The baud rate was set to 9600, the output rate set to 17 milliseconds, the data bits set to 8, and the stop bits set to 1. Finally, the settings for the output signal had to be adjusted. The range was set to +/- 10 V to reflect the measuring of forces in both tension and compression. In other words, when forces were recognized in compression, the SST would output a negative value, and when forces were recognized in tension, the SST would output a positive value. The screens within which these settings of the software programmer were adjusted can be seen below:

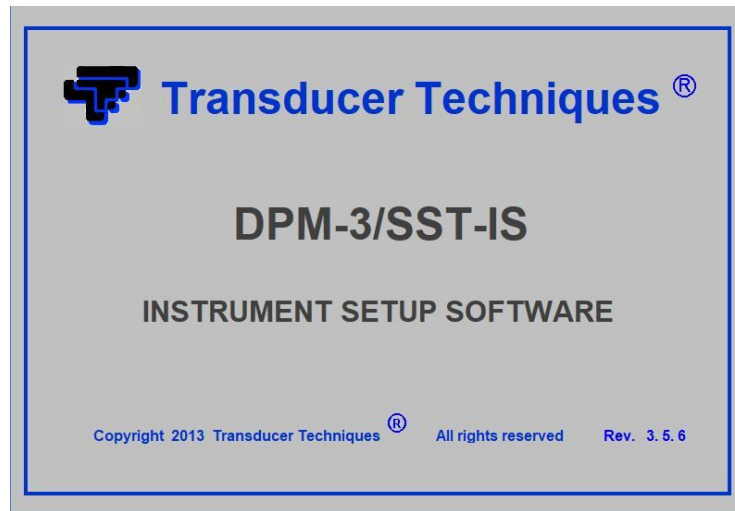

Image 19: Setup screen of software program used to interface with SST Transmitter [14].

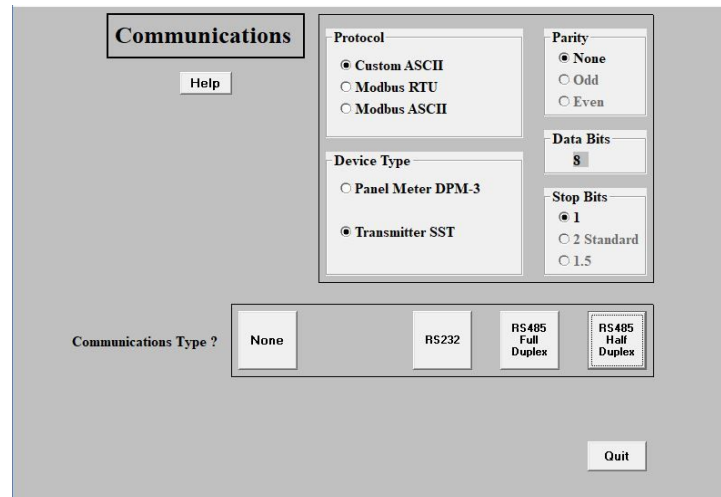

Image 20: Communications establishment screen, used to select basic settings and communication type [14].

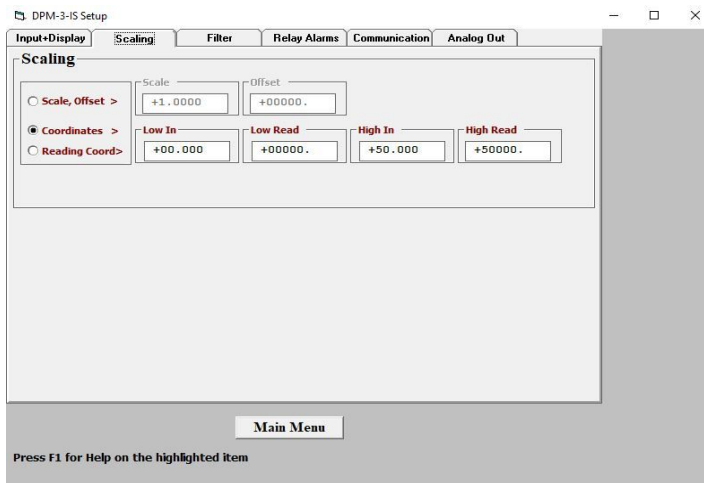

Image 21: Scaling screen, within which the input and output readings of the SST Transmitter could be adjusted [14].

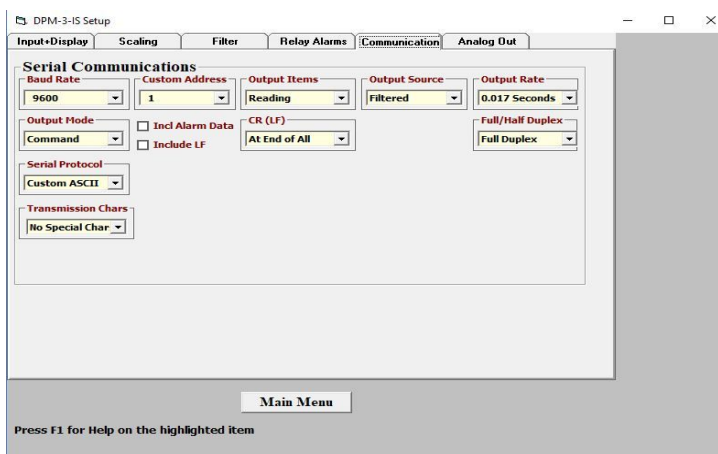

Image 22: Communications screen, within which the basic communication settings between the load cell and post-SST processor could be adjusted [14].

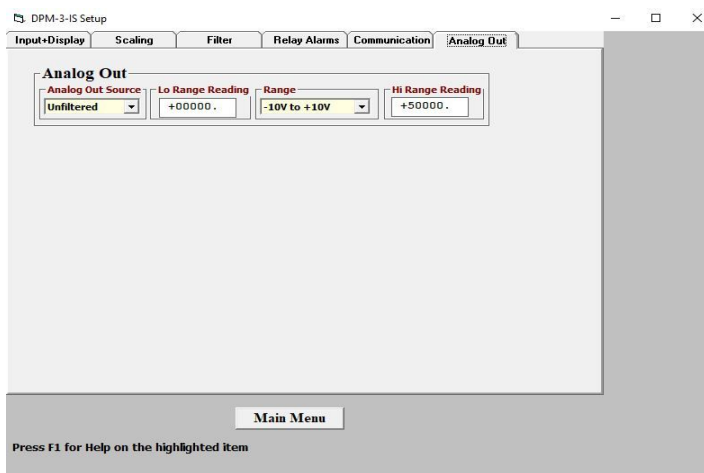

Image 23: Analog out screen, within which the SST transmitter output range could be adjusted [14].

Now, with all of the appropriate software settings in place, the output from the SST would be anywhere within a range of -10 to 10 V based on the forces recognized in the load cells either in tension or compression. Ideally, the output from the SST would be interfaced with an AD board using a BNC cable. This is the signal processing setup used in the research settings the LEST would be implemented in. However, for purposes of the end of semester presentation, an AD board and its accompanying complex setup were unrealistic to obtain. Instead, it was decided that the output from the SST Transmitter would be interfaced with an Arduino board, after which simple code could be written to provide a live plot of the forces recognized by the Arduino. However, Arduino's only take an input voltage maximum of +/- 5V, so the output from the SST transmitter first had to be run through a simple voltage divider. A voltage divider has an input going to one end, followed by two resistors. The output wire is placed between the two resistors, and the voltage in the output wire can be calculated as follows:

$$V_{out} = V_{in} \cdot \frac{R_2}{R_1 + R_2}$$

Image 24: Equation for calculating the output voltage of a voltage divider [1].

As can be seen from the above equation, if equal resistance values are used for both resistors, the output voltage will be one half that of the input voltage. This was exactly what was needed, as the SST output max was +/- 10 V but the Arduino could only handle a maximum of +/- 5 V. The analog output wire from the SST Transmitter was connected to two 10k Ohm resistors, and the output wire from the voltage divider was placed in the "A0" pin of the arduino. Then, through simple coding, the input into the Arduino, which was ultimately the force recognized by the load cell after all of the predescribed signal processing, was plotted to a live plot that could show the forces being exerted upon the push plate of the apparatus in real time. The exact coding used for this step can be found in Appendix, section D- Arduino Code.

E. Planned Testing

Testing will be focused on determining the accuracy of the device. Force plate testing will be performed with known weights to compare with the LEST device. This establishes whether the LEST would be a suitable alternative to the force plate which has an accuracy within 0.2% [16]. Three accuracy testing sections will be performed on the LEST. One will test the accuracy of the force registered in tension, another will test the accuracy of the load cells in compression, and a third will test whether certain heights of push plate result in a higher accuracy of measurement. Accuracy of forces in tension will be measured by placing the device upside down on a table and hanging weights from the push plates. Several different weights (5, 15, 25, 45, and 60lbs) will be used, and each weight will be tested three times. A similar testing procedure will be used for testing the accuracy of the compression measurements with weights placed on top of the push plate. Height tests will also be performed comparing the accuracy of different heights of the push plate. A weight will be placed on top of the push plate at different heights

measuring the output at each height three separate times. The percent accuracy will then be calculated. Finally, a comfort test will be performed in which three different users will rate their comfort using the device when the push plate is at three different heights.

VI. Discussion

The struggles encountered while working on the electronic components of the design led to a failure to perform any sort of testing with the device. After extensive troubleshooting and rewiring, it was determined that the electronic problems stemmed from a problem with the SST transmitter. This transmitter was provided and was most likely altered in some way that changed its functionality and prevented it from working correctly. Ethical concerns were not a large concern for the device. However, there is always a possibility of injury while subjects are exerting their maximum forces in a straight leg raise. Efforts were made to increase the subject's comfort while using the device. The supports were made sturdy enough to prevent excess movement and the push plate was low enough to the ground to prevent injury as the leg falls. Once data collection can commence, possible sources of error could include movement or bending of the HDPE sheet as the leg raise is being performed. Some of the forces exerted would be towards the movement of the HDPE instead of fully going toward the push plate. The lifting of the HDPE sheet occurs due to an insufficient weight holding it down. Once the electronic components of the device are operating correctly, data retrieved will most likely have an accuracy comparable to the force plates.

VII. Conclusion

For this study, participants will be asked to lie on their backs in a supine position and perform a straight leg raise task while their MVC (Maximum Voluntary Contraction) of the hip-flexors/knee-extensors are measured to determine pelvic instability. The device needs to be light, quick and easy to assemble, comfortable, and able to withstand the strength of an adult female who will be pressing against it. It was originally decided that the Jungle Gym design is the best because it scored highest on the design matrix indicating that it matches the design requirements closer than the alternatives. After changes in the client expectations regarding the use of force plates and the desire to have greater portability, the design was modified to be independent from the force plates and to contain load cells in the upper vertical supports. The device also features a push plate with an adjustable height to allow for the fatiguing task to be performed inside of the device which will eliminate downtime in between tests. There are still several adjustments that need to be made to the device to have a successful product design applicable in research.

A. Future Work

There are a number of small adjustments that can be made to this device to make it more effective. Adding height measurements etched into the aluminum support beams, for one, would allow clients to easily adjust the push plate to specific heights for testing. Another addition could be adding handles in a balanced location on the side of the base plate for easier transportability. This would be

helpful as the device is somewhat bulky. Hinge connections can be modified so that the HDPE sheets fold more effectively without putting stress on the hinge joints. The edges of the two parts of the base plate connected to the hinges should be filed down so that they clear each other when folding, allowing for the base plate to completely fold in half. Additional handles for the corner towers should also be ordered to replace the initially ordered ones that had too short of a handle length. The handles were so short on these that not enough torque could be produced to tighten the clamping design. These handles should have a thread size of $\frac{3}{8}$ "-16 and a stud length of 1.75". The handle length should be at least 2" long. The device is currently set up to interface with an arduino and laptop for presentation purposes. Ideally, it should be reconfigured to be compatible with an AD board with a BNC cable connection for use in clinical research. This is the setup that is utilized by Dr. Deering and Dr. Heiderscheit, so for actual clinical use it should be what the apparatus is designed to interface with. As the electrical malfunction has been narrowed down to the SST transmitter, this part should be reordered or sent in to the vendor in order for the problem to be diagnosed. After doing so, so the device should be able to register and output data.

As with many new products, there are ways to generally improve on how design specifications were met. The weight of the device is a variable that can be reduced in the corner towers, support beams, and base plate by using different materials and dimensions to cut down on unnecessary material. The HDPE sheet was \$216.25 of the \$511.86 spent and found to be relatively easily flexed if the MVC test was implemented incorrectly. Therefore, it is suggested that a more rigid material should be chosen to decrease flexibility, and a different geometric structure be chosen to decrease weight. Such a structure would limit material use, and therefore weight, while promoting rigidity possibly by imitating the structure of I or L beams. If weight in other aspects of the design are reduced, then a strong metal plate can replace or be added to the HDPE spanning from each support. This will decrease the flexibility encountered during application of the MVC to the push plate and will improve the accuracy of data acquisition.

VIII. References

- [1] Deering, R., Cruz, M., Senefeld, J., Pashibin, T., Eickmeyer, S. and Hunter, S. (2018). *Access Library Resource - UW Libraries*. [online] Ovidsp-tx-ovid-com.ezproxy.library.wisc.edu. Available at: <https://ovidsp-tx-ovid-com.ezproxy.library.wisc.edu/sp-3.31.1a/ovidweb.cgi?QS2=434f4e1a73d37e8c54ea12160ae198c537b03d6b8825264da6409e42530466e4ace2bfc484c2bb3b985f904a1878fc79cc06378cf858d61492358030ffdc042532ef75d3ba59c06c7693e7e2a44d772bbfa00c5ff514fe63b24e5622626491b12d6cbe821f440c17ed7d2fba8818869399ece28fcd5ff1637cc409dcc600b5d449776e10d5a709660e093c5197015ba37d4344534ce811ae70227eb2df94a9ace94b94ae7c59144f7f6c7498af3c76582c3329908aad25b2b6435edaeb1e9a4ae118ff39fde5a251d3aefc809397b7a19b4cc29fb70cd4a3a572378c4b157a3fbecfbef287a55927b8aed8efa0568119fcfeea102a9f874261bb891c2cc6499030067cbe7181ac5e8a2f06a95f9cda4ad98f8930c7239dc340575bd9e5f4e5f9a37c921704f4fed5242b512c98cc1e6e8933623b25d2123016b2f298195081a8701414daa4204c> [Accessed 10 Oct. 2018].
- [2] Eustice, C. (2017). *Do Loose Joints Cause Osteoarthritis?*. [online] Verywell Health. Available at: <https://www.verywellhealth.com/joint-laxity-and-osteoarthritis-2552209> [Accessed 10 Oct. 2018].
- [3] E. Andersson, J. Nilsson, Z. Ma and A. Thorstensson, "Abdominal and hip flexor muscle activation during various training exercises", *European Journal of Applied Physiology*, vol. 75, no. 2, 1997.

- [4] Therapeutic Associates Physical Therapy. (2018). *Lumbopelvic Stability - Therapeutic Associates Physical Therapy*. [online] Available at: <https://www.therapeuticassociates.com/lumbopelvic-stability/> [Accessed 9 Oct. 2018].
- [5] Keane, D., Sims, T., Abrams, P. and Bailey, A. (1997). Analysis of collagen status in premenopausal nulliparous women with genuine stress incontinence. *BJOG: An International Journal of Obstetrics and Gynaecology*, [online] 104(9), pp.994-998. Available at: <https://obgyn.onlinelibrary.wiley.com/doi/full/10.1111/j.1471-0528.1997.tb12055.x> [Accessed 9 Oct. 2018].
- [6] Mens, J., Vleeming, A., Snijders, C., Koes, B. and Stam, H. (2001). *Reliability and Validity of the Active Straight Leg Raise Test in Posterior Pelvic Pain Since Pregnanc*. 26th ed. [ebook] Rotterdam, The Netherlands: Erasmus University of Rotterdam, pp.1167-1171. Available at: [http://file:///C:/Users/Noah%20Nicol/AppData/Local/Packages/Microsoft.MicrosoftEdge_8wekyb3d8bbwe/TempState/Downloads/Mens,%20JMA.%202001%20\(2\).pdf](http://file:///C:/Users/Noah%20Nicol/AppData/Local/Packages/Microsoft.MicrosoftEdge_8wekyb3d8bbwe/TempState/Downloads/Mens,%20JMA.%202001%20(2).pdf) [Accessed 9 Oct. 2018].
- [7] Thompson, N. (2017). *Muscles That Move the Leg*. [online] Acefitness.org. Available at: <https://www.acefitness.org/fitness-certifications/resource-center/exam-preparation-blog/3594/muscles-that-move-the-leg> [Accessed 10 Oct. 2018].
- [8] White, Robert M. (1982). *Comparative Anthropometry of the Foot*. [online] Available at: <http://www.dtic.mil/dtic/tr/fulltext/u2/a126189.pdf> [Accessed 10 Oct. 2018].
- [9] Alonso, Angelica Castilho. (2016). *The Effects of Foot Morphology and Anthropometry on Unipodal Postural Control*. [online] Available at: <https://www.semanticscholar.org/paper/The-effects-of-foot-morphology-and-anthropometry-on-Alonso/20ae2160192a010af0d905ff3f4d8284d6a6c52a> [Accessed 10 Oct. 2018].
- [10] C. D. Fryar, Q. Gu, C. L. Ogden, and K. M. Legal, "Anthropometric Reference Data for Children and Adults: United States, 2011–2014," *CDC*. [Online]. Available: https://www.cdc.gov/nchs/data/series/sr_03/sr03_039.pdf. [Accessed: 08-Dec-2018].
- [11] D. A. Winter, *Biomechanics and motor control of human movement*. Hoboken, NJ: Wiley, 2009.
- [12] Transducertechniques.com. (2018). *MLP Series mini low profile Load Cell*. [online] Available at: <https://www.transducertechniques.com/mlp-load-cell.aspx> [Accessed 08 Dec. 2018].
- [13] Transducertechniques.com. (2018). *SST Smart Sensor Transmitter*. [online] Available at: <https://www.transducertechniques.com/pdf/SST-manual.pdf> [Accessed 8 Dec. 2018].
- [14] "MINI LOW PROFILE LOAD CELL UNIVERSAL / TENSION OR COMPRESSION," *Load Cell Manufacture*. [Online]. Available: <https://www.transducertechniques.com/mlp-load-cell.aspx>. [Accessed: 12-Dec-2018].
- [15] J. Blom, "Voltage Dividers," *Voltage Dividers*. [Online]. Available: <https://learn.sparkfun.com/tutorials/voltage-dividers/all>. [Accessed: 08-Dec-2018].

[16] *BP400600 Force Platform*. 176 WALTHAM STREET WATERTOWN, MA: ADVANCED MECHANICAL TECHNOLOGY, INC., 2018.

VIII. Appendix

A. PDS

LEST (Lower Extremity Strength Tester)

Product Design Specifications

Client: Dr. Bryan Heiderscheit and Dr. Rita Deering

Team: Sam Parmentier, Dan Wildner, Kaitlin Lacy, Brittany Glaeser, Noah Nicol

10/7/2018

Function:

During and after pregnancy, it is common for women to experience a loss of strength in the muscles of the pelvic girdle that can lead to pelvic instability. This can cause serious pain and discomfort, and new methods are continually being researched to relieve women of this condition during their already

challenging pregnancy and the busy months after. Currently, to determine if a patient has pelvic instability, a doctor has them perform a straight leg raise and rate the difficulty of doing so on a scale of zero to five. If the patient gives a rating of anything other than zero, the doctor then compresses the hips at the sides and has the patient try the straight leg raise again. If the extra pressure from the doctor makes the straight leg lift easier, this is indicative that the patient may have pelvic instability. One of our clients, Dr. Rita Deering, has performed comprehensive research that concluded that pregnancy has a significant impact on the strength of the pelvic girdle muscles, but is now trying to quantitatively analyze the extent of the effect it has. Therefore, a device is needed that can assess a maximal voluntary contraction (MVC) of the hip flexor (iliopsoas) and knee extensor (quadriceps, rectus femoris) muscles during a straight leg raise task to assess the loss of strength in the lower extremities of women both during and after pregnancy as a result of pelvic instability. This device will be completely portable and will have load cells implemented into it to allow for the measurement of this MVC during testing.

Testing Procedure:

While laying down with their feet inside this device, the subject will first perform an unassisted leg raise with one leg to fatigue it. The push plate will be in its lowest position, and both feet will be within the bars of the push plate while one leg uses the area in between them to perform the fatiguing task. The leg not performing the fatiguing task will remain on top of the push plate so that the load cells can record in compression how much force that foot pushes down with. This fatiguing task will be performed until failure, which is achieved once the foot drops beneath 10 cm or excessive lumbopelvic motion occurs (measured by an air bladder underneath their lower back). Then, the push plate will be raised to an appropriate height and the fatigued leg will immediately perform a straight leg lift. The MVC produced by that leg will be recorded near the ankle of that leg. The leg that did not partake in the fatiguing exercise will rest on the bottom plate of the design, which does not interact in any way with components fixed to the load cells. This process will then be repeated with the opposite leg on a separate day.

Client requirements:

- Design must be completely portable so as to be used in multiple research and clinical settings.
- The device must be strong enough to withstand an MVC from an adult female performing a straight leg lift.
- The device must be in place and ready to use within a minute after subject's fatiguing task to prevent muscle recovery.
- Comfort (or a lack of) of the test subject must not limit the amount of force able to be produced.
- A budget of \$1000 must be kept.
- The device must be designed so that it can be used when the patient is supine (lying on the floor).
- The subject should not be able to hold onto the device in any way, and secondary help from a doctor or different test subject should not be required to hold the device in place.
- Load cells integrated into the design will be used to measure the MVC of the subject.
- Those load cells must interface with an A to D board used by the clients and their existing software.

- The surface of the design that the subject will press against with their ankle must not be uncomfortable to the point of causing pain, but must also not be too soft as to absorb the force of the MVC.
- The device must be conducive to the specific testing procedure detailed above.

Design requirements:

1. Physical and Operational Characteristics

a. Performance requirements:

- The device must have load cells integrated into it in order to accurately record the MCV of the test subject.
- The device will be used frequently in UW-Health Research Park as well as other lab setting locations during the lifetime of the research project, and therefore must be completely portable
- The device must not require any fixturing specific to a certain research location.
- Able to withstand the force of a straight leg raise at maximum effort for an adult female
 - Muscles involved: iliopsoas, quadriceps, and rectus femoris.
- The device must help to consistently and accurately measure the force of a lower body MVC (the force plate will be doing the quantitative measuring).
- There must be adequate room within the device for the fatiguing task to be performed.
- All portions of the device must be fully compatible with the specific testing procedure detailed above.

b. Safety:

- Comfortable for patients to exert force without pain
- Able to easily accommodate patients of varying sizes, with the lower body size being of particular concern.
- Sturdy enough to avoid collapse and/or fracture from a lower body maximal muscle exertion of an adult female.
- No sharp or rough edges or protruding parts that could injure subjects as they use the device or the clients as they put the device in place.

c. Accuracy and Reliability:

- The device needs to contribute to an accurate reading from the force plate over multiple tests with varying patients (within 5% accuracy). This may require the ability to adjust on a per patient basis (in terms of height of apparatus).
- The device should limit the area the patient can be situated in in order to maintain the position of the straight leg lift.

d. Life in Service:

- The two main locations the apparatus will be used are in UW-Health Research Park Clinic and the Badger Athletic Rehabilitation Training Center. However, it may be used in additional clinical settings.
- Needs to be available at any time of the day for extended periods of time. The number of cycles of MVC measuring is still yet undetermined.

e. Operating Environment:

- The device will be used and stored in a clinical setting.
- The largest chance for damage will likely occur during transport between clinics or while under stress from force applied by patient.
- Possible causes of failure could arise when subject is trying to get inside the apparatus and their leg/body collides with the apparatus in some way.

f. Ergonomics:

- Must be strong enough to easily withstand maximum contortion of hip flexor and knee extensor muscles of an adult female.
- Must allow a wide range of adult females to place feet into device
 - The interacting force bar needs to have enough space to accommodate a wide range of adult female ankles

g. Size:

- The apparatus must be wide and high enough to comfortably fit the lower legs/feet of any size adult female between its frame.
- The frame of the device will largely be sized based upon anthropometric data regarding the hip width and body length of the average American adult female.

h. Weight:

- The maximum weight of the device is 50 lbs, as it will need to be lifted and transported by one person between locations.
 - Ideally, the design will weigh much less than this.

i. Materials:

- No materials restrictions have been placed on this project as far as incompatibility with other equipment being used during the testing procedure.
- The frame will likely be comprised of aluminum tube.
- The part of the device interacting with subject needs to be comfortable but not so soft that it absorbs the force of their MVC. A harder rubber material will likely be used.

j. Aesthetics, Appearance, and Finish:

- All seams, joints, and welds should be neat and aesthetically pleasing.
- There should not be any unfinished edges or contact points.
- No extraneous materials should be hanging down, protruding from, or in any way seen on the device.

- The device's appearance should be comparable to the professional exterior of exercise equipment.

2. Production Characteristics

a. Quantity:

- One LEST will need to be produced.

b. Target Product Cost:

- A budget of \$1000 dollars for this project has been set. Other competing designs have a cost of around \$1000 dollars, so it would be preferred that our design does not reach that cost level.

3. Miscellaneous

a. Standards and Specifications:

- No FDA approval is required.
- Some lab standards may need to be met based on the policies of our client's lab environment.

b. Customer:

- This design is not intended for commercial sale. For concerns of subjects utilizing the designs, please look below to "patient related concerns."

c. Patient-related concerns:

- Patient data confidentiality must be considered. The numerical value of MVC's of patients will be recorded, which is private information between the patient and the doctor performing tests.
- This device will be used for pregnant and postpartum women, so comfort is a major concern.
 - Subject must easily be able to perform the MVC test quickly after completing a fatiguing exercise.
- The testing of the apparatus involves creating a maximum force with certain muscles, so we want any surface of the device that a subject is pressing against to not cause them any pain or discomfort.

d. Competition:

- MICROFET 2 MANUAL MUSCLE TESTING (MMT) HANDHELD DYNAMOMETER - \$1,054
 - The Microfet 2 is an ergonomically-designed dynamometer that accurately measures the force produced by a certain muscle.

- Doctor's test-
 - A simple test that doctors use to measure if a patient has pelvic instability is to press against the sides of their hips and ask if that makes it easier for them perform the leg lift. If they say it does, they are considered to have pelvic instability.
- Training of whole leg waist abdominal muscle of lying on back power and test system - CN # 201520291327
 - This patent seemed to describe an apparatus that measured forces created similar to the ones in our testing procedure.

B. Materials List

TO BE ORDERED:					
Part Number	Description	Vendor	Cost	Qty	Subtotal
4698T150	Tee Through-Hole Connector for 1" Pipe	McMaster Carr	\$8.89	2	\$17.78
4698T320	90 Degree Elbow Connector for 1" Pipe	McMaster Carr	\$11.25	2	\$22.50
8974K13	6061 Aluminum Round, 1 " DIA x 6' Length	McMaster Carr	\$30.63	2	\$61.26
8975K264	2" x 3" x 24" Aluminum Bar	McMaster Carr	\$94.34	1	\$94.34
8619K117	48" x 96" x 1/2" HDPE Sheet	McMaster Carr	\$216.25	1	\$216.25
1603A27	Brass Surface Mount Hinges	McMaster Carr	\$4.56	5	\$22.80
8647K46	Foam Yoga Mat	Amazon	\$28.79	1	\$28.79
64835K19	Zinc Adjustable Position Handle- 1/4-20 x 1 9/16"	McMaster Carr	\$11.65	2	\$23.30
8975K87	6061 Aluminum Bar, .25" thick x 3" Wide, 2' Length	McMaster Carr	\$15.09	1	\$15.09
75315A53	Foam Mounting Tape, .194" Thick x .5" Wide · 48' Length	McMaster Carr	\$9.75	1	\$9.75
				TOTAL	\$511.86

C. Detailed Fabrication Process

The following parts are final sized parts that need to be fabricated for the assembly of the LEST apparatus:

1" DIA Aluminum Round- 6.125" Length (Bottom Vertical Support)				2
1" DIA Aluminum Round- 9" Length (Top Vertical Support)				2
1" DIA Aluminum Round- 20" Length (Top Horizontal Support)				1
1" DIA Aluminum Round- 17.125" Length (Push Plate Support)				2
.25" x 3" x 19" Aluminum Bar- Push Plate				1
2" x 3" x 10" Aluminum Bar- Corner Tower				2

.5" x 24" x 40" HDPE Sheet- Front Base Plate			1
.5" x 20" x 32" HDPE Sheet- Back Base Plate			1
Foam Padding to match above base plate pieces			1

The methods for creating each part will be described in detail in the order they are presented above:

1" DIA Aluminum Round- 6.125" Length (Top Vertical Support)- x2

1. On drop saw, cut a 6.25" length off of 6' stock material.
2. On lathe, face one end and file the edges. Measure overall length, flip piece around, touch off on rough face, and enter measured length into DRO. Face part down to finished length of 6.125".
3. Turn end down to $\frac{3}{8}$ " DIA with a depth of .3125".
4. Thread $\frac{3}{8}$ " stud along the full .3125" length using a $\frac{3}{8}$ -24 NF die.
5. Break sharp edges.

1" DIA ALuminum Round- 9" Length (Bottom Vertical Support)- x2

1. On drop saw, cut a 9.125" length off of 6' stock material.
2. On lathe, face one end and file the edges. Measure overall length, flip piece around, touch off on rough face, and enter measured length into DRO. Face part down to finished length of 9".
3. Turn end down to $\frac{3}{8}$ " DIA with a depth of .3125".
4. Thread $\frac{3}{8}$ " stud along the full .3125" length using a $\frac{3}{8}$ -24 NF die.
5. Break sharp edges.

1" DIA Aluminum Round- 20" Length (Horizontal Support)- x1

1. On drop saw, cut a 20.125" long piece off of 6' stock material.
2. On lathe, face one end and file the edges. Measure overall length, flip piece around, touch off on rough face, and enter measured length into DRO. Face part down to finished length of 20".
3. Break sharp edges.

1" DIA Aluminum Round- 17.125" Length (Push Plate Vertical Support)- x2

1. On drop saw, cut a 17.25" long piece off of 6' stock material.
2. On lathe, face one end and file the edges. Measure overall length, flip piece around, touch off on rough face, and enter measured length into DRO. Face part down to finished length of 17.125".
3. On same face, make a pre-drill indentation using a #2 center drill.

4. Drill a 1" deep hole using a size I drill bit.
5. Countersink the hole.
6. Tap the hole to its maximum depth using a 3/8"-16 NC tap.
7. Break sharp edges.

.25" x 3" x 19" Aluminum Bar- Push Plate- x1

1. On drop saw, cut a 19.125" length piece off of .25" x 3" x 24" stock material.
2. On mill, touch off on one rough face and face it off. Measure the overall length. Touch off on the opposite face and input the measured length. Mill the piece to the finished length of 19".
3. Using an edge finder, locate the X and Y directions on the front left corner of the part.
4. Beginning with a #2 center drill, make a small pre-drilling hole in the piece at 1.5" in the y direction and 1.1875" in the x direction. Make an additional indentation at 1.5" in the y direction and 17.8125" in the x direction.
5. First using a 1/4" twist drill, drill through the plate at both of these locations. Do so again using a letter X drill bit.
6. Deburr all sharp edges.

2" x 3" x 10" Aluminum Bar- Corner Tower- x2

1. To first create the left side tower, on drop saw, cut 10.125" long piece from 2"x3"x24" stock.
2. With the long edge of the part laying horizontally in the vice of a mill, touch off on one face and completely face it off. Measure the overall length of the bar. Then, touch off on the opposite face and enter the measured length into the DRO. Mill the part down to the finished 10" length.
3. Attach an angle plate to the mill table and indicate it using a dial indicator. With the long edge now vertical and the 3" face touching the angle plate, sandwich the part between the fixed angle plate and an additional free angle plate using a C-clamp. Place a large vice stop on the fixed angle plate so that it is flush with the edge of the part.
4. Program the mill to move to four separate hole positions. Assuming the origin is at the front left corner, the hole locations are (.5", .5"), (1.5", .5"), (1.5", 2.5"), and (.5", 2.5"). Program three additional repeat cycles after programming the hole positions for drilling, countersinking, and tapping.
5. Using an edge finder, locate the the x and y faces of the part, making the origin at the front left corner.
6. Begin the CNC program, first using a #2 center drill. Make a pre-drilling indentation at each of the four locations. Continue moving through the program, progressively using a #7 twist drill to drill a hole depth of 1.2", a countersink, and a 1/4 -20 NC tap.
7. Position the quill over the (1", 1.5") location of the part. Use a #2 center drill to make a pre-drill indentation.
8. Beginning with a 1/4" twist drill, drill a hole to the maximum depth allowable by the drill bit. Repeat using a 3/8" drill bit.

9. Using a morse taper adapter for the quill, again drill as deep as possible using a $\frac{3}{4}$ " drill bit, and then a 1" drill bit. The hole should be just past 5" deep.
10. Loosen the part from the angle plate and flip it over, making sure it is flush with the fixed angle plate and the vice stop. This will ensure that no additional locating will be necessary.
11. Again, position the quill over the (1", 1.5") location of the part. Repeat steps 8 and 9 so that the 1" drill bit breaks through and a complete 1" hole is made throughout the tower.
12. Using a 1.001" reamer, ream the 1" through hole completely.
13. Using a 3/16" endmill, create a relief cut centered on the 2" face of the part, extending from the edge to the center hole on both sides. The relief cut should be 1" deep.
14. Place the part back in the vice, with the long edge again horizontal and the relief cut on the front right side of the vice. Edge find on the front right corner of the part.
15. First using a #2 center drill, create a pre-drill indentation at (-1", 1"). Drill to a depth of 1.6875" using a #7 twist drill.
16. Create a clearance hole at the same location with a letter I drill bit, drilling deep enough so that the clearance hole reaches the relief cut.
17. Using a $\frac{1}{4}$ -20 NC tap, tap the #7 DIA hole on the opposite side of the relief cut.
18. Repeat this process at a location of (-1, 2") to create a second hole.
19. With the 2" wide face of the tower flat on the table of a bandsaw, line the blade up with the center of the relief cut and extend it to be 3.5" deep total.
20. In the vice of the mill, place either of the 2" faces down against the bottom of the vice. Extend the end of the tower with the relief cut far enough out to the right of the vice that a 5/16" through hole can be drilled at the bottom of the relief cut. This will be done for stress relief to reduce the propagation of cracking.
21. Begin with edge finding the part on the front right corner, and make a small indentation with a center drill at the (-3.5, 1) position after doing so.
22. Without moving the table, drill through the tower with the 5/16" bit.
23. Using a 1" four flute end mill with a 3" LOC, position it against the Y face of the right end of the part. Zero the DRO.
24. Now, position the end mill against the front X face of the part. Zero the DRO.
25. Using the "GO TO" feature, program the mill so that you can't go past (-3.5", .25")
26. Begin milling down the face of the part with the clearance holes, NOT the tapped holes. Take .300" off each pass until a depth of .25" is reached in the Y direction, going all of the way to -3.5" in the X direction every time.
27. To create the right side tower, this entire process should be followed until step 13. In this step, the relief cut should again be placed on the right side of the vice but should be facing the BACK of it. Then, the following steps can again be followed. In this way, the clearance hole and tapped hole will start on the opposite side of the tower, so that the left and right towers are mirror images of each other.

.5" x 24" x 40" HDPE Sheet- Front Base Plate- x1

1. On panel saw, cut a 25" x 48" piece out of an 8' x 4' sheet of $\frac{1}{2}$ " thick HDPE.

2. On a table saw, cut the width down to the finished 24" and the length down to the finished 40".
3. Make a mark 2" from each edge of the 24" width and 7" from one end of the part. Using the table saw with the blade high, cut out the 2" x 33" section on each side of the board.
4. On the mill, write a program to mill out three 2.0625" x .75" profiles that are all .1875" deep. One should be centered along the 20" side of the board, and the other two are exactly 5.875" away on each side of the centered profile.
5. Also program three holes to be drilled, all .21875" from the edge of the board, .9375" apart, with the center hole being in the center of the profile.
6. Remove the vice and fixture the board to the table of the mill, with the long edge running parallel to the table. Edge find the X and Y faces and set the origin at the extreme right edge of the board, in the center of the 20" length. Run these programs to mill out the three profiles and drill three holes in each profile, all using a #37 twist drill.
7. Write an additional program to drill 8 more holes. Assuming the origin will be at the front left corner of the left fin, the hole locations will be (.5", .5"), (1.5", .5"), (22.5", .5"), (23.5", .5"), (23.5", 2.5"), (22.5", 2.5"), (1.5", 2.5"), (.5", 2.5). Program two repeat cycles for drilling and countersinking.
8. Place the long 24" length of the board along the length of the table. Edge find and set the origin at the front left corner of the left fin. Run the program and drill using a letter I drill bit. Countersink deep enough to accommodate the head of a 1/4-20 flat head socket head screw.

.25" x 20" x 32" HDPE Sheet- Back Base Plate- x1

1. On panel saw, cut a 21" x 48" piece out of an 8' x 4' sheet of 1/2" thick HDPE.
2. On a table saw, cut the width down to the finished 20" and the length down to the finished 32".
3. On the mill, write a program to mill out three 2.0625" x .75" profiles that are all .1875" deep. One should be centered along the 20" side of the board, and the other two are exactly 5.875" away on each side of the centered profile.
4. Also program three holes to be drilled, all .21875" from the edge of the board, .9375" apart, with the center hole being in the center of the profile.
5. Remove the vice and fixture the board to the table of the mill, with the long edge running parallel to the table. Edge find the X and Y faces and set the origin at the extreme right edge of the board, in the center of the 20" length. Run these programs to mill out the three profiles and drill three holes in each profile, all using a #37 twist drill.

D. Arduino Code

```
int loadcellPin = A0; // input pin for load cell
int sensorValue = 0; // variable to store the value coming from the sensor

void setup() {
  // declare the ledPin as an OUTPUT:
```

```
pinMode(loadcellPin, INPUT);  
// initiate serial communication  
Serial.begin(9600);  
}  
  
void loop() {  
  // read the value from the sensor:  
  loadcellValue = analogRead(loadcellPin);  
  newtons = (300/1023)  
  Serial.print(loadcellPin);  
}
```

E. CAD Drawings

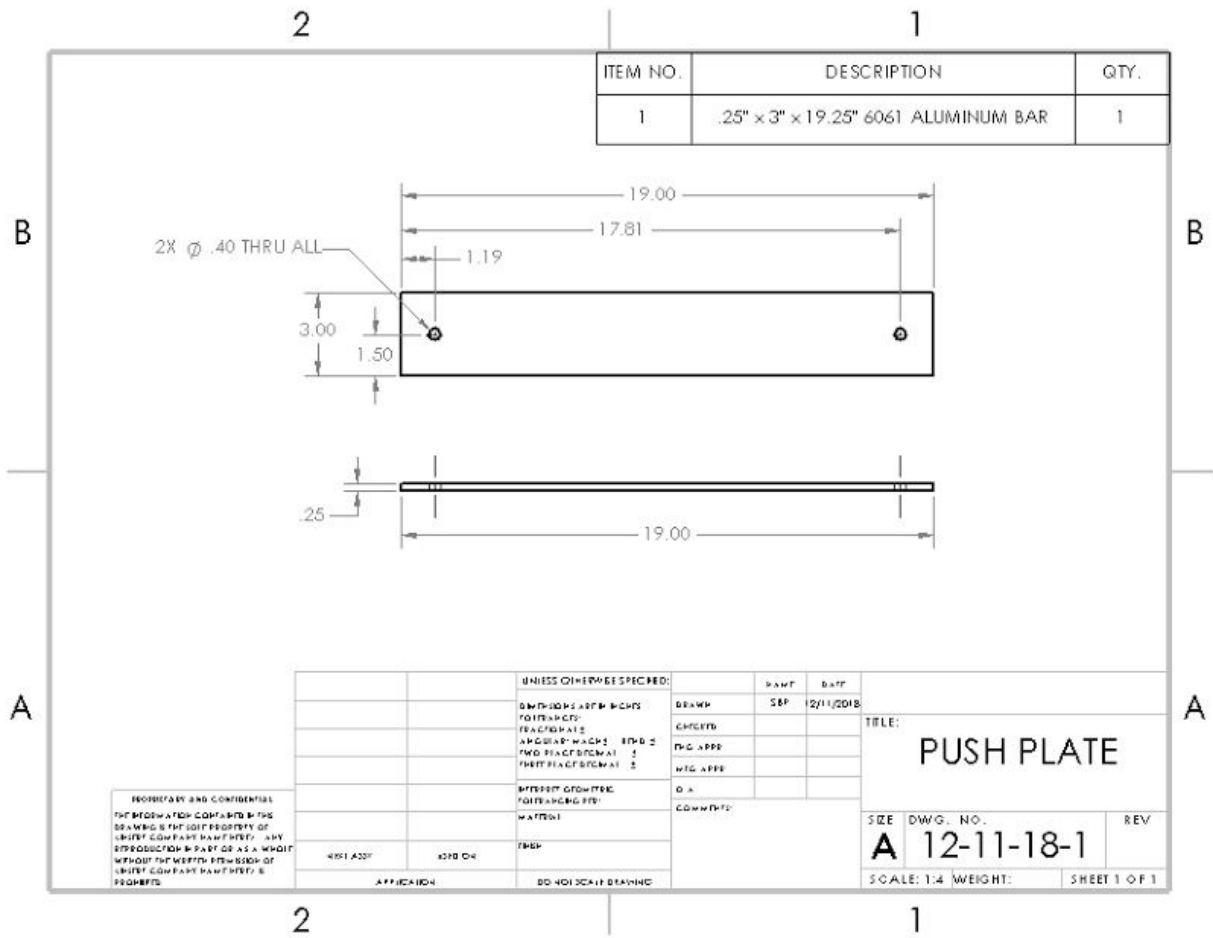

Image 1: Detailed drawing of the Push Plate (part 12-11-18-1).

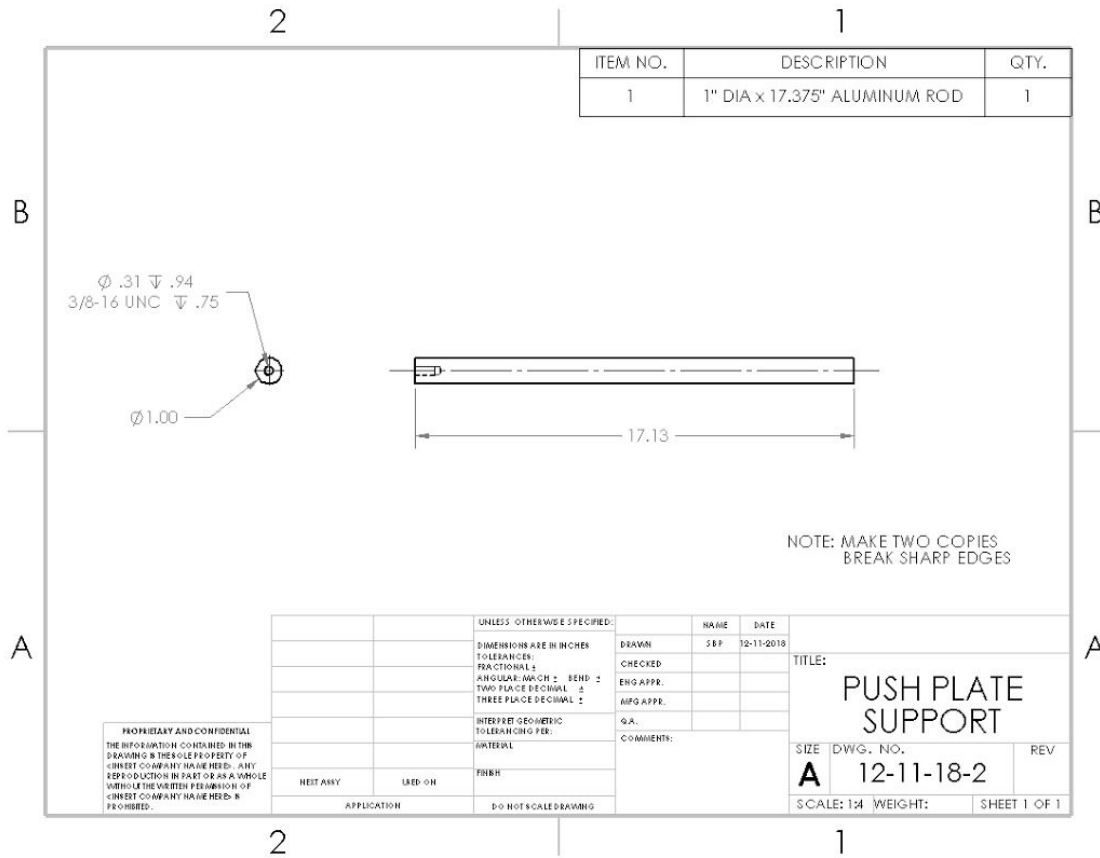

Image 2: Detailed drawing of the Push Plate Support (part 12-11-18-2).

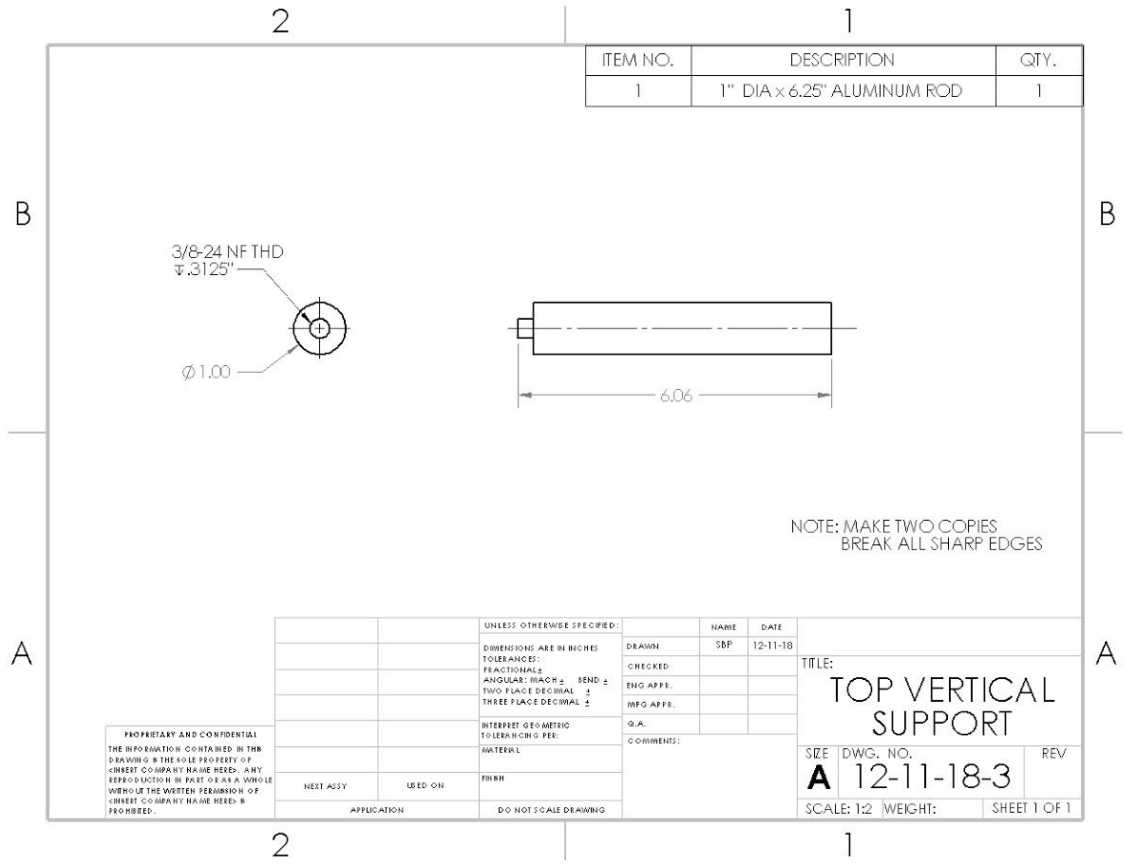

Image 3: Detailed drawing of the Top Vertical Support (part 12-11-18-3).

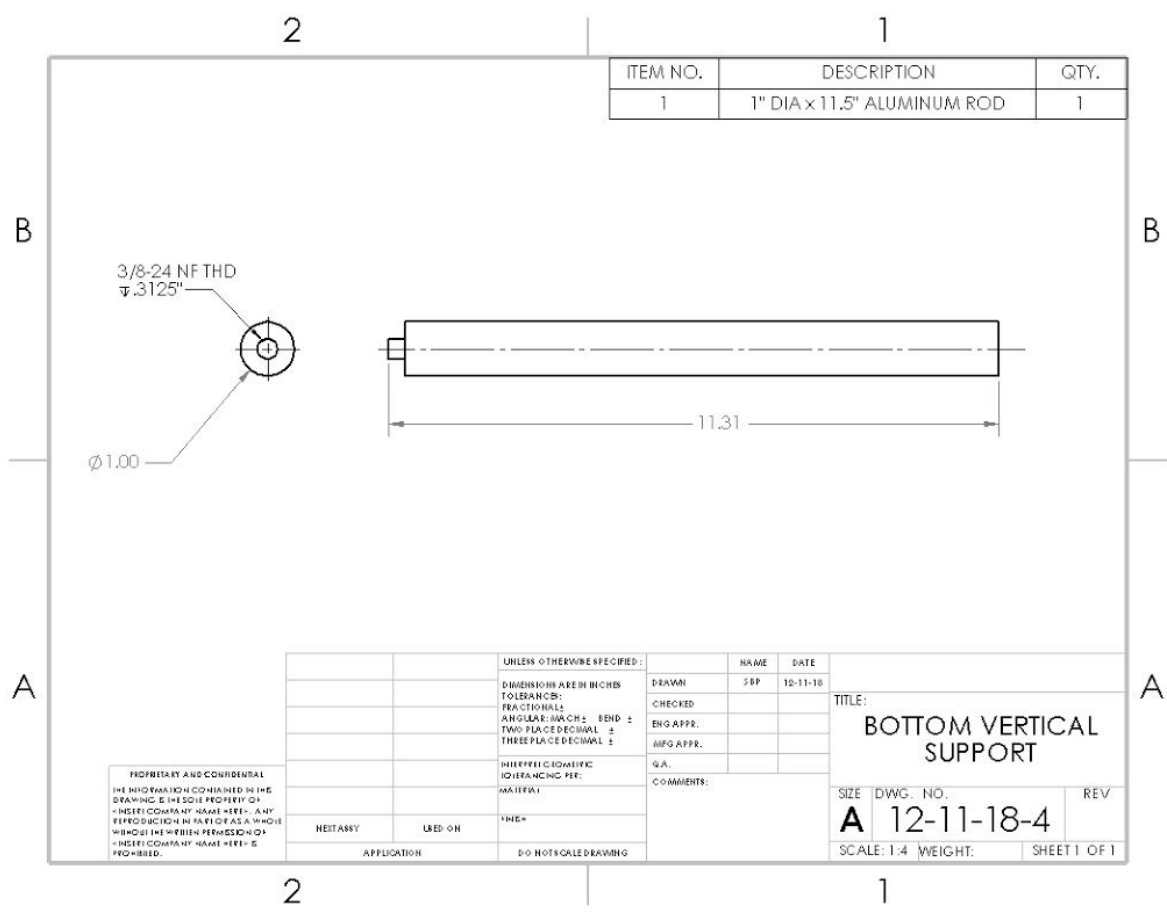

Image 4: Detailed drawing of the Bottom Vertical Support (part 12-11-18-4).

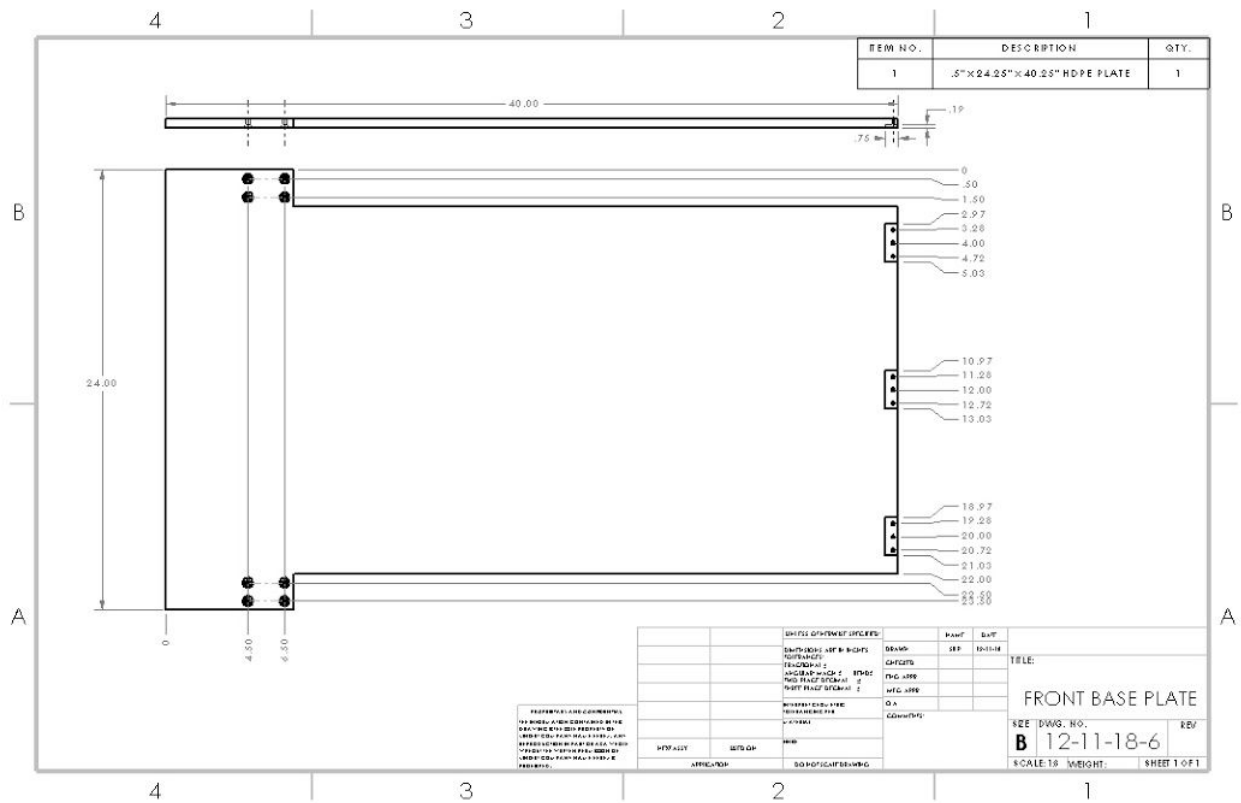

Image 6: Detailed drawing of the Front Base Plate (part 12-11-18-6).