

# BME Design-Fall 2020 - Arrington Polman Complete Notebook

PDF Version generated by

KATHERINE KONIECZKA

on

Dec 09, 2020 @12:24 PM CST

## Table of Contents

Project Information	2
Team contact Information	2
Project description	3
Team activities	4
Client Meetings	4
9/11/2020 Client Meeting 1	4
9/25/2020 Client Meeting 2	5
10/19/2020 Client Meeting 3	6
10/30/2020 Client Meeting 4	7
11/20/2020 Client Meeting 5	8
Advisor Meetings	9
9/11/2020 Advisor meeting 1	9
9/18/2020 Advisor meeting 2	10
9/25/2020 Advisor meeting 3	11
10/9/2020 Advisor Meeting 4	12
10/16/2020 Advisor Meeting 5	13
10/23/2020 Advisor meeting 6	14
10/30/2020 Advisor meeting 7	15
11/6/2020 Advisor meeting 8	16
11/13/2020 Advisor Meeting 9	17
11/20/2020 Advisor meeting 10	18
Design Process	19
2020/9/7 Team meeting Introduction	19
2020/9/23 STL files and solidworks upload	20
2020/9/24 Design Matrix	21
2020/10/14 Materials design matrix	24
2020/10/20 3d scanning mandible	26
Materials and Expenses	27
2020/12/5 Final Expenses	27
Materials Design Matrix	29
Fabrication	30
2020/10/1 - Fabrication Plan	30
Testing and Results	32
Protocols	32
FEA Testing Protocol	32
Experimentation	35
2020/12/1 FEA matlab analysis	35
2020/12/2 Matlab analysis	36
Design Documents	37
PDS	37
Preliminary Report	38
Arrington Polman	39
Research Notes	39
Biology and Physiology	39
2020/9/6- Mandible Fractures in Dogs	39
2020/9/12 Dog bite and bone research	41

2020/11/11 Mechanics of bone formation	45
Competing Designs	46
2020/9/11 Computer Model Research	46
2020/9/27 Muzzle dimensions	48
Materials Research	49
2020/10/17 Fabric Materials	49
2020/10/17 Support rod material research	50
Design Ideas	51
2020/9/22 Velcro & Clip Idea	51
2020/9/27 Detailed mesh design	52
2020/10/6 Cadaver Measurements	53
FEA/CAD	55
2020/10/4 FEA softwares	55
2020/10/28 Solidworks Reduction attempts	56
2020/11/17 Blender CAD intro	57
2020/11/19 CAD Fitting	59
2020/11/29 Finishing Model	60
2020/11/11 ECB Solidworks attempts	61
Hand Calculations of Stress	62
2020/10/15 FBD and Calculations for supports	62
2020/10/18 Hand calculations of stress at fracture	64
2020/10/25 Adding reaction force to hand calculation	65
2020/11/22 Makerspace Rod Consultation	67
Training Documentation	68
Green Pass	68
Biosafety, Responsible Conduct of Research, Human Subjects Basics	69
Katherine Konieczka	70
Research Notes	70
Biology and Physiology	70
2020/09/09 - Mandibular Fractures in Dogs	70
Dimensions of a Dog Mandible	71
Mechanical properties of bone	80
Competing Designs	81
Competing and Existing Designs	81
Standards and Specifications	84
Mechanics Research	85
2020/09/09 Mechanics - cantilever	85
Design Ideas	86
Preliminary Design	86
Materials	87
Solidworks/FEA simulations	88
FEA simulation attempt 1	88
FEA simulation attempt 2	92
FEA simulation attempt 3	94
Alexandria Thao	98
Research Notes	98
Biology and Physiology	98
9/10/20 - Mandibular Treatments	98
9/16/20 - Canine forces in the mandible	100
Materials	102
10/6/20 - Polyamide (Nylon)	102
10/15/20 - Polyester	104
10/15/20 - Cotton	105
10/16/20 - Polypropylene	106
10/16/20 - Aluminum	107
11/30/20 - Bone	108
Mechanics	109
9/17/20 - Suspension and Cantilever Bridge Mechanics	109
10/5/20 - SolidWorks FEA	111
Design Ideas	112
9/23/20 - Initial Design Sketches	112

10/1/20 - Fabrication Plan	114
11/3/20 - SolidWorks Muzzle	116
11/30/20 - Simplified Jaw Part	117
Jakob Knauss	118
Research Notes	118
Biology and Physiology	118
9/9/20 - Mandibular Fracture Repair in Dogs	118
9/16/20 - Forces on the Mandible	121
Materials	123
10/14/20 - Polypropylene Material Properties	123
10/14/20 - Nylon Material Properties	124
10/14/20 - Mesh Material Properties	126
10/14/20 - Thermoplastics Material Properties	127
Mechanics	128
10/7/20 - Cantilever Mechanics	128
Design Ideas	129
9/23/20 - Preliminary Design	129
10/28/20 - Jaw Model Hand Calculations	130
SolidWorks	131
10/21/20 - 3D Scans	131
11/12/20 - SolidWorks Tutorial Videos	132
11/18/20 - Attempt at SolidWorks Muzzle Design	134
Training Documentation	135
Red Pass (Spring 2020)	135
Matthew Wroblewski	136
Research Notes	136
Biology and Physiology	136
9/10/2020 General Background Research	136
9/16/2020 Tape Muzzles	138
Mechanics and Mathematics	140
9/10/2020 Bridge Mechanics	140
9/24/2020 3D Model Geometries	141
9/30/2020 Solidworks FEA	143
10/30/2020 Idealized Calculations	144
Materials	146
10/21/2020 3D Printing filaments	146
10/19/2020 Canvas/Mesh Materials	147
11/7/2020 Review of Peer Feedback	148
Design Ideas	152
9/22/20 Preliminary Designs	152
Solidworks/FEA	153
10/21/2020 3D Jaw Scan	153
10/24-10/29/2020 3D scan evidence of reduction attempts	156
11/24/2020 Rough model	160
12/1/2020 FEA Overview	163
Training Documentation	164
Red Permit	164
Sydney Appleton	165
Research Notes	165
Biology and Physiology	165
2020/9/8- Tape versus Nylon Muzzles	165
2020/9/16 - Compressive Forces in Canines	167
2020/11/12 - Dog Bite Force Measurements	168
2020/12/5 - Impact of Nylon Muzzle	170
Mechanics	171
2020/9/16 - Background on Bridge Mechanics	171
2020/9/30 - Finite Element Analysis in SolidWorks	173
2020/11/02 - Hand Calculation Attempt	174
2020/11/25 - FEA Model	175
2020/11/28 and 2020/11/29 - FEA Simulation Attempts	176
Materials	177

Battens .....	178
2020/10/15 - Polypropylene .....	178
2020/10/15 - Nylon (Polyamide) .....	180
2020/10/15 - Aluminum/Other Metal .....	181
Nylon/Mesh .....	182
2020/10/16 - Cotton .....	182
2020/10/16 - Polyester .....	184
2020/10/4 - Nylon Properties and Cost .....	186
Design Ideas .....	188
2020/9/22 - Preliminary Design .....	188
2020/10/01 - Fabrication Plan .....	189
2020/12/6 - Analysis and Discussion of Results .....	191
2014/11/03-Entry guidelines .....	192
2014/11/03-Template .....	193



## Team contact Information

ALEXANDRIA THAO - Sep 11, 2020, 12:06 PM CDT

Last Name	First Name	Role	E-mail	Phone	Office Room/Building
Ashton	Randolph	Advisor	dr.randolphashton@gmail.com		
Thatcher	Graham	Client	graham.thatcher@wisc.edu		
Polman	Arrington	Leader	ampolan@wisc.edu		
Konieczka	Kate	Communicator	kkonieczka@wisc.edu		
Knauss	Jakob	BSAC	jaknauss@wisc.edu		
Wroblewski	Matthew	BWIG	mdwroblewski@wisc.edu		
Thao	Alexandria	BPAG	athao26@wisc.edu		
Appleton	Sydney	BPAG	sappleton2@wisc.edu		



## Project description

---

Arrington Polman - Dec 08, 2020, 9:07 AM CST

**Course Number:** BME Design 300/200

**Project Name:** VetMed: Affordable Muzzle to Assist in Canine Mandibular Fracture

**Short Name:** VetMed: Affordable Muzzle

**Project description/problem statement:** In veterinary medicine there is a gap in treatment options for mandibular fracture repairs in canines. The current treatments available require costly surgeries and the tape muzzles that are used to stabilize the fracture up to and after surgery can displace the fracture further. In order to reduce costs and improve the quality of care, our client would like the team to design an improvement upon nylon muzzles using principles of cantilever and suspension bridge construction that can be used as an alternative to the standard treatment options. Using finite element analysis, the team will compare the stress that the improved nylon muzzle places on the fracture site compared to the standard tape muzzle. The muzzle must be able to withstand bite forces of 620.33-1,091.1 N and evenly distribute those forces throughout the jaw [5]. Through these tests the team must quantitatively prove that nylon muzzles are the superior treatment option when dealing with mandibular fracture repairs in canines.

**About the client:** Our client, Dr. Graham Thatcher, is part of the Surgical Sciences at University of Wisconsin- Madison's School of Veterinary Medicine. In his experience, he has encountered many maxillofacial injuries in canines. He has expressed his displeasure with current teachings of the tape muzzle design and would like scientific evidence that shows other designs providing superior support for healing.



## 9/11/2020 Client Meeting 1

---

KATHERINE KONIECZKA - Sep 11, 2020, 1:29 PM CDT

**Title:** Client Meeting 1

**Date:** 9/11/2020

**Content by:** Kate Konieczka

**Present:** All

**Goals:** Meet the Client and discuss his goals for the project as well as ask any questions that we might have

**Content:**

**Started off the meeting by introducing ourselves, Dr. Thatcher asked us what we knew already about the project, then we dove into questions**

- baton sail to reinforce the muzzle

Questions

- Would like to prove with using radio graphs or mathematically that nylon muzzles are superior to tape muzzles

- tape muzzles go over fracture and can move and displace it

- dogs with more crowded jaws are more prone to fracture

- muzzle needs to be adjustable

- top is shorter than the bottom due to where support is needed

- Velcro on the top

- s/m m/l for the sizes

- muzzles can help save the dog and lower the cost for owner. Helps get the dog to surgery. The idea would be a muzzle that could fit a feeding tube that way surgery could be prolonged

- can print stuff at his lab

- the team is going to each come up with a design

- he will make a drawing and send it to us

- we will meet every other Friday at 8

- looking into commercially available muzzles

- quantifying support in those muzzles

- modeling with batons in the muzzle

- types of attachment in muzzles

- look into material and where we can fabricate

**Conclusions/action items:**

We plan to meet next September 25th at 8am. Each of us will work on an initial drawing of a muzzle and Dr. Thatcher will send us his idea for the baton reinforcement. Overall the meeting was productive and the team now has a better understanding of what we need to do moving forward.



## 9/25/2020 Client Meeting 2

---

KATHERINE KONIECZKA - Sep 29, 2020, 8:19 AM CDT

**Title:** Client meeting 2

**Date:** 9/25/2020

**Content by:** Kate Konieczka and Arrington Polman

**Present:** All

**Goals:** Go over preliminary designs and discuss possible ways to model a dog mandible in Solidworks

**Content:**

Preliminary designs

- Design 1 - Zipper
  - Liked the idea of having a zipper on the side to aid in feeding a drinking
- Design 2 - Molar
  - With favorable fractures (most likely the type we will be dealing with) this design will not aid in the healing process
  - a strap would not fit between the dog's ears and the eyes
- Design 3 - Mesh
  - Liked the idea of the mesh being incorporated in the design to help with breathability.

Dr. Thatcher also liked the idea of having support over the nose.

The team is going to pick up a dog mandible. Next we will measure it in order to create an accurate model in Solidworks.

**Conclusions/action items:**

Going forward the team has a good idea of the design we are going to create to test against the tape muzzle. We will start the design process in solid works and hopefully start testing soon





## 10/19/2020 Client Meeting 3

---

KATHERINE KONIECZKA - Dec 08, 2020, 9:58 PM CST

**Title:** Client Meeting 3

**Date:** 10/19/2020

**Content by:** Kate Konieczka

**Present:** All

**Goals:** Go over our preliminary design ideas with our client

**Content:**

The team met with our client to finalize our design ideas and discuss our issues with FEA. We talked to our client about ordering materials, specifically the battens, nylon and mesh. We also discussed the possibility of making the battens removable to customize the fit more.

**Conclusions/action items:**

The team will begin to order materials and hopefully begin to fabricate the muzzle soon. We are discussing possibly using the maker space 3D printer and a sewing machine. We are going to reach out to the makerspace to schedule a consultation.



## 10/30/2020 Client Meeting 4

---

KATHERINE KONIECZKA - Dec 09, 2020, 6:06 AM CST

**Title:** Client Meeting 4

**Date:** 10/30/2020

**Content by:** Kate Konieczka

**Present:** All

**Goals:** Discuss our troubles with FEA and brainstorm solutions with our client.

**Content:**

We updated our client on our progress with getting the 3D scans of the skulls into Solidworks. We were able to mesh the scan so that they could be opened in SolidWorks however the mesh was too complicated to run any simulations on. Our client mentioned that there is a software called Materialize 3 Matic that might help with the complexity of our scans. He informed us that he would reach out to colleagues and see about getting us access. I was also going to email Dr. Puccinelli and see if he knew who has access in the BME Department.

**Conclusions/action items:**

The team will email Dr. Puccinelli about the Materialize software in the BME department and continue attempting FEA on either the 3D scan or our own models in the mean time.



## 11/20/2020 Client Meeting 5

---

KATHERINE KONIECZKA - Dec 09, 2020, 6:11 AM CST

**Title:** Client Meeting 5

**Date:** 10/20/2020

**Content by:** Kate Konieczka

**Present:** All

**Goals:** Discuss our FEA progress with our client.

**Content:**

We informed Dr. Thatcher that we were able to get into contact with several members of the engineering department regarding the Materialize software. We also updated him on our progress in regards to ordering materials.

**Conclusions/action items:**

We will continue to work on FEA and get into contact with the professors that have access to see about setting up a meeting to discuss it. We will also work on putting together our muzzle prototype.



## 9/11/2020 Advisor meeting 1

---

Arrington Polman - Sep 13, 2020, 12:41 PM CDT

**Title:** First Advisor Meeting

**Date:** 9/11/2020

**Content by:** Kate, Arrington

**Present:** All

**Goals:** Have first meeting with Professor Ashton, set guidelines for project and upcoming week.

**Content:**

solid works based project

need a server where the solid works file would be located???

quantitative value for fracture pressure

relate it to the force of the dogs bite need threshold

evolve problem statement

set up a metric that we are trying to achieve

Logistics Based

- Update problem statement with numbers, boundary conditions
- Need new team picture on the website
- Create PDS draft (due next week)
- Oct. 2nd is preliminary presentations

Project

- look for dog mandible models for solidworks, would be able to show stresses w/ fea
  - would need to find variables to change, how each design would affect the model
- Research into pressures in dog bite, ideal pressures for fracture healing. This will help set thresholds for our PDS.
  - We might be able to ask graham if we are unable to find in research
- Muscles that open the mandible, where to attach forces for the model

**Conclusions/action items:**

We will need to research into forces and pressures experienced by a dog mandible during biting, opening, and relaxed states. Will also seek mandible models for solidworks. During our weekly team meeting, we will set boundary conditions for our problem statement and PDS, and put a new team photo on the website.



## 9/18/2020 Advisor meeting 2

---

KATHERINE KONIECZKA - Sep 19, 2020, 9:18 PM CDT

**Title:** Advisor meeting 2

**Date:** 9/18/2020

**Content by:** Kate Konieczka

**Present:** All

**Goals:** Go over initial PDS, go over what needs to be done before the next client and advisor meeting and discuss logistics

**Content:**

### **PDS feedback**

- Make sure to keep updating and improving problem statement throughout the semester
- The numbers provided in the initial PDS look good
- Maximize the amount of primary references used
- Correct the citation number 4
- Clarification on whether the force we need is the force of the jaw closing or opening?
- Define the type of nylon we are going to use
- Give quantitative values for sizing

### **Logistics**

- Make sure everyone knows how to use Solidworks to some extent - this is going to mainly a Solidworks based project
- For the future on the progress reports we only need on row for the activities
- 

**Conclusions/action items:**



## 9/25/2020 Advisor meeting 3

---

KATHERINE KONIECZKA - Sep 29, 2020, 8:10 AM CDT

**Title:** Advisor meeting 3

**Date:** 9/25/2020

**Content by:** Kate Konieczka

**Present:** All

**Goals:** Go over design matrix and discuss possible ways to generate a dog mandible in Solidworks

**Content:**

Design Matrix Notes

- Post PDS and Design matrix to the website
- Revise problem statements
  - Did we solve that problem?
- Criteria
  - Maybe change safety to functionality
  - support vs ergonomics how are we going to measure whether or not a dog is comfortable
  - Change size to adjustability
  - Need to make sure each criteria is distinct and doesn't overlap with other ones
  - better name for usability would be ease of use

Notes on Presentation

- Need to introduce problem
- justify our design matrix
- Talk about what we plan to do to create our simulation

**Conclusions/action items:**

The team will need to go back and adjust our design matrix criteria. We will also begin inputting measurements of a dog mandible into Solid works to begin creating our simulation. In addition to this we will put together our preliminary presentation.



## 10/9/2020 Advisor Meeting 4

---

KATHERINE KONIECZKA - Dec 09, 2020, 9:26 AM CST

**Title:** Advisor meeting 5

**Date:** 10/9/2020

**Content by:** Kate Konieczka

**Present:** All

**Goals:** Discuss our progress with Dr. Ashton and update him on our FEA struggles

**Content:**

Dr. Ashton discussed with us the requirements for the show and tell. He would like us to have our simulation complete by show and tell so we can get feedback on it. While we try and get the skulls canned Dr. Ashton suggested making a simplified model to test. We also talked with him about our plans to fabricate.

**Conclusions/action items:**

The team will work on creating a simplified model of the mandible in SolidWorks and our material that we will present for show and tell.



## 10/16/2020 Advisor Meeting 5

---

KATHERINE KONIECZKA - Dec 09, 2020, 9:29 AM CST

**Title:** Advisor meeting 6

**Date:** 10/16/2020

**Content by:**

**Present:** All

**Goals:** Update Dr. Ashton on this weeks progress

**Content:**

The team discussed with Dr. Ashton the materials we are considering for our muzzle prototype. Arrington discussed his preliminary hand caluclations with Dr. Ashton. We are still in the process of setting up a meeting with the Makers Space to 3D print but our goal is to have that done by the next meeting

**Conclusions/action items:**

The team will work on setting up a meeting with the makerspace to 3D scan the skulls and finalize our materials.





## 10/23/2020 Advisor meeting 6

---

KATHERINE KONIECZKA - Dec 09, 2020, 9:31 AM CST

**Title:** Advisor meeting 7

**Date:** 10/23/2020

**Content by:** Kate Konieczka

**Present:** All

**Goals:** Update Dr. Ashton on our progress

**Content:**

We informed Dr. Ashton that we 3D scanned the muzzle. We were able to get accurate measurements from the scan when imported into SolidWorks. The team will now work on simulations in SolidWorks on the 3D scan.

**Conclusions/action items:**

The team will continue to work on FEA on the 3D scan, finalize and order materials and develop a plan to fabricate



## 10/30/2020 Advisor meeting 7

---

KATHERINE KONIECZKA - Dec 09, 2020, 9:35 AM CST

**Title:** Advisor meeting 8

**Date:** 10/30/2020

**Content by:** Kate Konieczka

**Present:** All

**Goals:** Update Dr. Ashton on our progress.

**Content:**

The team has had a lot of trouble getting the scan to work properly in SolidWorks. We shared our struggles with Dr. Ashton and he suggested created a simplified model in Solidworks. We also shared our plans to order materials for the prototype.

**Conclusions/action items:**

Moving forward the team will keep working on the FEA and hopefully get the scan to work. In the meantime we will develop a simplified model of the mandible to be tested in SolidWorks.



## 11/6/2020 Advisor meeting 8

---

Sydney Appleton - Dec 09, 2020, 10:17 AM CST

**Title:** Advisor meeting 8

**Date:** 11/6/2020

**Content by:** Sydney Appleton

**Present:** All

**Goals:** Discuss our plan for the rest of the semester, software, and materials.

**Content:**

We shared our plan with Dr. Ashton for the rest of the semester. We also asked him about the 3-matic software that our client suggested; however, he was unfamiliar with who in the BME department has access to it. His suggestion was to stick with SolidWorks as it may be too difficult to learn and execute. We shared the beginning of our plan for materials and reviewed some feedback from show and tell.

SolidWorks feedback:

- Put 3-matic aside for now.
- Work on simplifying mandible.
- Reach out to others for assistance as peers may have more experience.

**Conclusions/action items:**

We will use the feedback to begin looking at purchasing our materials and continue with modeling a simplified mandible in SolidWorks.



## 11/13/2020 Advisor Meeting 9

---

Sydney Appleton - Dec 09, 2020, 10:17 AM CST

**Title:** Advisor meeting 9

**Date:** 11/13/2020

**Content by:** Sydney Appleton

**Present:** All

**Goals:** Discuss our plan for ordering materials and modeling in SolidWorks.

**Content:**

Materials:

- We told Dr. Ashton we plan to order materials in the upcoming weekend.

SolidWorks:

- We discussed our difficulties with the STL files in SolidWorks.
- Dr. Ashton suggested focusing on a more simplified model.
- Crucial to get simple simulation running to go forward with our project.

**Conclusions/action items:**

The team will finalize purchases this weekend and begin to work on a model around the STL files and begin FEA on that simplified mandible.



## 11/20/2020 Advisor meeting 10

---

Sydney Appleton - Dec 09, 2020, 10:17 AM CST

**Title:** Advisor Meeting 10

**Date:** 11/20/2020

**Content by:** Sydney Appleton

**Present:** All

**Goals:** Discuss plan for FEA in SolidWorks and purchased materials.

**Content:**

We told Dr. Ashton about the materials we had purchased and our plan to begin sewing next week. We had previously split up into groups for the CAD muzzle and simplified jaw. Since we are still having troubles with the SolidWorks model and simulation, we asked for advice on how to carry forward. From this point, we will go forward with the simplified model backup plan to get our simulation done.

**Conclusions/action items:**

After creating a simplified mandible model in SolidWorks, we will attempt another FEA simulation.



## 2020/9/7 Team meeting Introduction

---

Arrington Polman - Sep 13, 2020, 12:48 PM CDT

**Title:** Initial team meeting

**Date:** 9/7/2020

**Content by:** Arrington

**Present:** All

**Goals:** Get to know each other and have an idea of what the project goals are

**Content:**

We all met on microsoft teams and found a good time that would work most weeks to work as a team.

During this meeting:

Team Based

- Went over introducing ourselves
- took a team picture for the website
- made sure everybody had access to labarchives, the group drive, and group chat
- went over the due date for the upcoming progress report

Project Based

- Found the best time that would work for our client meetings
- Went over goals for the project. Everybody has a fairly good idea of the goals of the project. Since it is improving a design and not creating something completely new, we all have a general idea of the goal. The main issue is going to be a way to validate the designs. During our client meeting on Friday, we will get a better understanding and additional input from our client.

**Conclusions/action items:**

We will each continue research, and plan for the client meeting on Friday.



## 2020/9/23 STL files and solidworks upload

---

Arrington Polman - Oct 07, 2020, 8:21 AM CDT

**Title:** STL files into Solidworks

**Date:** 9/23/2020

**Content by:** Arrington

**Present:** Arrington, Kate

**Goals:** Load STL files from Will/Graham into solidworks

**Content:**

Kate and I talked with a past bme design team to get STL files from CT scans of a canine mandible. The idea is to import these detailed stl files into solidworks, and then run FEA on them. Using the remote citrix made it difficult to download and find the files to add into solidworks. Once located, we were able to import the file as a mesh. However, loading this file took a very long time, approximately 5 minutes, and once loaded, it was not editable. This means that we would not be able to remove any pieces of the head, add forces to specific teeth, or combine it with a muzzle model. We decided to talk with the makerspace on how to work with these files more. If we cannot use this detailed stl file, we will have to create our own model of the mandible, which will lost significant detail.

After this, we reviewed FEA and building parts in solidworks, before showing the 200s the basics. I created a simple part and ran FEA on it. When running FEA, it was necessary to use the most coarse mesh, otherwise my computer could not handle it. This is an issue in being required to use our own computers, rather than specific solidworks computers. We may look into ways to use a different software that will run smoother, or get access to the computers with more power.

**Conclusions/action items:**

We will talk with our advisor, and the makerspace on methods of adding stl files to solidworks, or different methods of FEA.

# 2020/9/24 Design Matrix

Arrington Polman - Dec 08, 2020, 9:44 AM CST

**Title:** Design Matrix

**Date:** 9/24/2020

**Content by:** Arrington

**Present:** All

**Goals:** Create and evaluate design matrix

**Content:**

We have each been working on our individual designs, and today we met and worked through most important attributes and our designs.

**Design Matrix Criteria**

Designs Criteria (*weight)	Design One		Design Two		Design Three		Existing Design	
	Zipper		Molar		Mesh		Tape	
Safety (25)	9/10	22.5	4/10	10	9/10	22.5	3/10	7.5
Support (25)	8/10	20	6/10	15	8/10	20	0/10	0
Ergonomics (15)	7/10	10.5	5/10	7.5	8/10	12	1/10	1.5
Size (15)	8/10	12	6/10	9	7/10	10.5	5/10	7.5
Material (10)	9/10	9	9/10	9	9/10	9	2/10	2
Cost (5)	6/10	3	8/10	4	8/10	4	10/10	5
Usability (5)	8/10	4	5/10	2.5	7/10	3.5	3/10	1.5
<b>Total (100)</b>		<b>81</b>		<b>57</b>		<b>81.5</b>		<b>23.5</b>

\*Note: When referring to weight it is always x/100

**Design Specifics**

Design 1 (zipper): The design will be a sleeve with battens sewn in for added support. It will buckle with straps to the back of the head. At the both sides of the mouth, there will be zippers with underlying mesh or breathable material. The zippers can be unzipped to allow for movement to eat or drink.

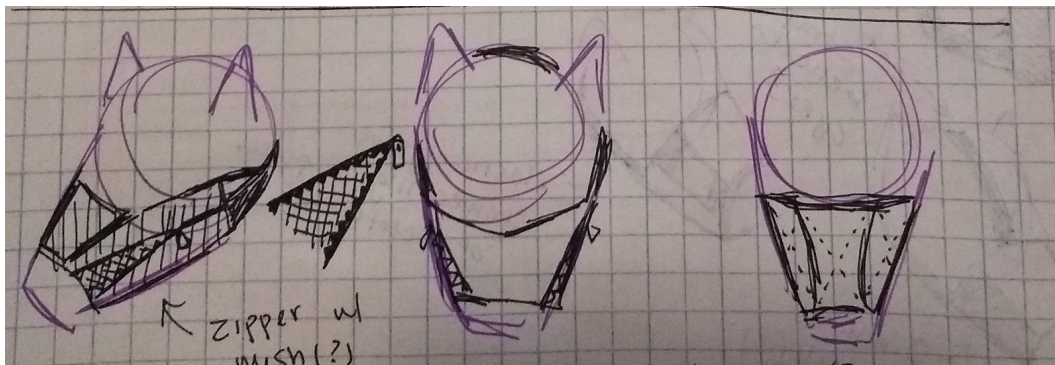

Design 2 (molar): This design features a specific portion of the muzzle deliberately not applying pressure around the molar area on either side of the jaw. The underside would also have battens running through it to disperse the the rest of the mandible equally. Another unique aspect of this design is the side strap as



well as the back of the head strap rather than over the front of the head or just back of the head. This may cause difficulties with slippage but could be changed at a later date if the underside idea pans out and would want to be used in future designs.

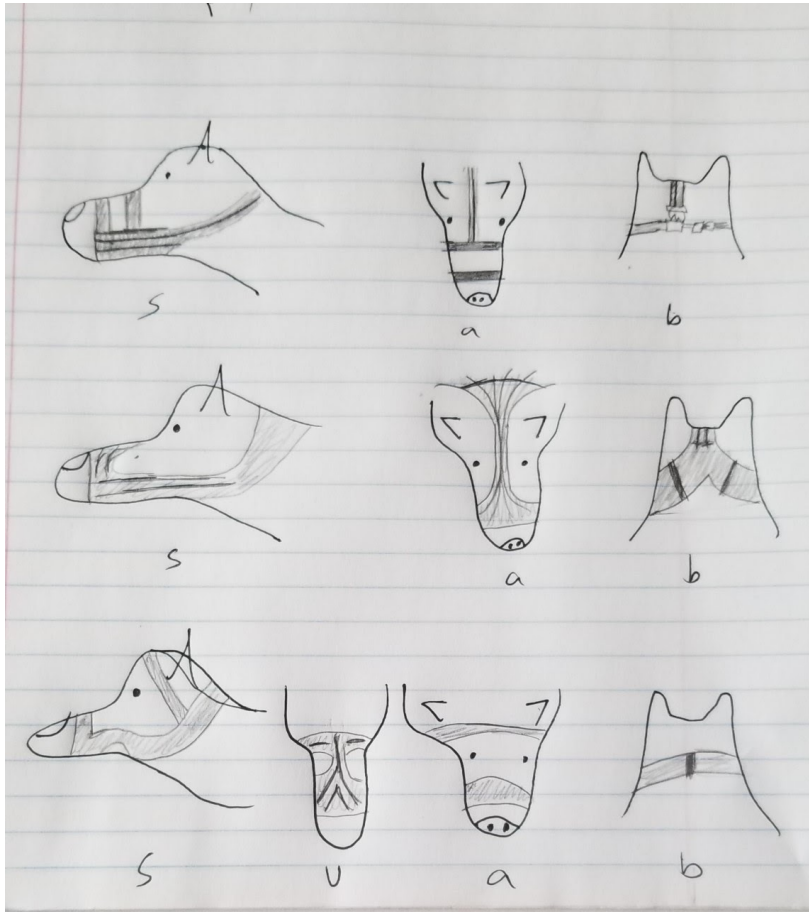

Design 3 (mesh): The design will feature a nylon underside with batten supports running laterally through it. The muzzle will buckle together at the back of the head with a strap running laterally across the face and reaching the back of the head. The rest of the muzzle will have mesh for breathability which will be attached to straps wrapping around and connecting to the nylon underside.

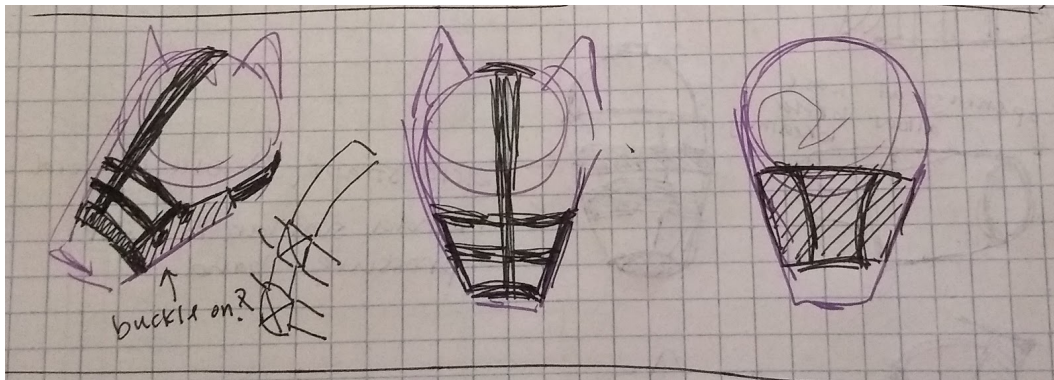

Existing design (tape): The existing tape design simply uses two pieces of tape around the mandible which is then wrapped around the base of the skull to keep it in place.



**Design Criteria Descriptions:**

- Safety - Must be able to properly drink and eat soft food. The design cannot restrict blood flow to the jaw or throughout the head. It must be washable to avoid growth of bacteria.
- Support - Ability to support the mandible by distributing the force throughout the mandible away from the area of interest allowing proper support for healing, limiting side effects.
- Ergonomics for the dog - The adjustable strap should be breathable and lightweight in order for the canine to perform daily needs such as eating, drinking, and panting. Takes into account the support, comfort, and range of motion.
- Size - Takes into account ability for 3 different sizes to be manufactured, and is compatible for transportation taking up as little space in the immediate area surrounding the head as possible. Pieces should be flush to the skull of the dog. It should also be adjustable and adaptable.
- Material - Any materials should be non-toxic and non-abrasive to the dog. Avoid metals if possible due to the unnecessary weight and rigidity. It must be lightweight and allow airflow to not overheat the dog.
- Cost - The total cost to produce and test the muzzle.
- Usability - The owner should be able to put on and remove the muzzle easily. The design should be durable and easy to clean.

**Conclusions/action items:**

We will advance by working with our mesh design, and may incorporate some aspects of the zipper design.



# 2020/10/14 Materials design matrix

Arrington Polman - Dec 08, 2020, 9:38 AM CST

**Title:** Materials design matrix

**Date:** 10/14/2020

**Content by:** Arrington

**Present:** All

**Goals:** Create a materials design matrix and decide goals coming up to show-and-tell

**Content:**

Our team met today to rank our most important qualities in a muzzle fabric and support rod material. We also had enough research to immediately fill out the fabric matrix.

## Nylon/Mesh Design Matrix

Designs Criteria (*weight)	Design One		Design Two		Design Three	
	Nylon Mesh	Cotton Mesh	Polyester Mesh			
Durability (30)	10/10 30	4/10 12	7/10 21			
Breathability (30)	7/10 21	9/10 27	7/10 21			
Cost (20)	8/10 16	7/10 14	9/10 18			
Flexibility/Comfort (15)	9/10 13.5	5/10 7.5	7/10 10.5			
Ease of Fabrication (5)	9/10 4.5	7/10 3.5	9/10 4.5			
<b>Total (100)</b>	<b>85</b>	<b>64</b>	<b>75</b>			

\*Note: When referring to weight it is always  $x/100$

- Canvas? Can be made of cotton, nylon, or polyester
- Nylon vs polyester mesh

Durability - Must be able to be worn daily for 5-6 weeks without tearing

Breathability- Must allow adequate airflow to the dogs fur

Cost - Must stay within budget (\$500)

Flexibility/Comfort- Doesn't allow for tangling of fur or interference with breathing, drinking, or eating

Ease of Fabrication- Team must be able to fabricate with COVID accessible tools and be reproduced by sophomore/junior level engineering students. Must be sewable to different components of muzzle.

## Batten Material Design Matrix

Designs Criteria (*weight)	Design One	Design Two	Design Three
----------------------------	------------	------------	--------------

	Polypropylene	Nylon (Polyamide)	Aluminum/Other Metal
--	---------------	-------------------	----------------------

Strength (30)			
---------------	--	--	--

Cost (25)			
-----------	--	--	--

Ease of Production (20)			
-------------------------	--	--	--

Flexible (w/ elasticity) (15)			
-------------------------------	--	--	--

Durability (10)			
-----------------	--	--	--

<b>Total (100)</b>			
--------------------	--	--	--

\*Note: When referring to weight it is always  $x/100$

- Polypropylene (PP) and nylon (polyamide) resin available at MakerSpace (Ultimaker 3D printer) Will retain shape after torsion, bending and flexing, is elastic over a certain range but is also tough, which means it will deform plastically not elastically, and it can be easily fabricated using a CNC cutter or 3D printer.
  - Can also buy sheets → midland plastics

Strength- Ability to resist deformation with increasing load

Cost - must stay within the budget (500 dollars)

Flexible, but elastic - material's ability to be bent but still retain original shape

Durability - ability of the material to not wear down over time/use

Ease of Production - team must be able to fabricate with COVID accessible tools, and be reproduced by sophomore/junior level engineering students

### Conclusions/action items:

Will all do more research into support rod materials before filling out this matrix.



## 2020/10/20 3d scanning mandible

---

Arrington Polman - Dec 07, 2020, 9:14 AM CST

**Title:** Makerspace 3d scanning

**Date:** 10/20/2020

**Content by:** Arrington

**Present:** Arrington, Kate, Jakob, Alex

**Goals:** 3d scan the mandible from our client

**Content:**

The team met outside the makerspace at 9 today to 3d scan our mandible. We observed the process from a safe distance on with the makerspace employees screenshared to a tv screen in the lab. The top and bottom pieces of the jaw were scanned, each as there own stl, and then the two files were also combined to ensure they properly connected. The STL files were then shared via a google docs shared drive.

The original STL files are below.

**Conclusions/action items:**

We will attempt to import these files into solidworks to get a detailed model for fea.

---

Arrington Polman - Dec 07, 2020, 9:17 AM CST



**jaw\_1\_.stl(5.5 MB) - [download](#)** Original 3d scans of jaw and snout. We expect to do the majority of work on the jaw.

---

Arrington Polman - Dec 07, 2020, 9:17 AM CST



**Skull\_no\_jaw.stl(11.8 MB) - [download](#)** Original 3d scans of jaw and snout. We expect to do the majority of work on the jaw.

 **2020/12/5 Final Expenses**

**Title:** Review of final expenses

**Date:** 12/5/2020

**Content by:** Arrington Polman

**Present:** All

**Goals:** Review total expenses to request reimbursement

**Content:**

Expenses:

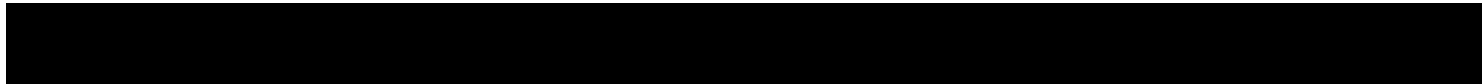

**Component 1**

**Ben Textiles**

**Power Mesh**

**Black Fabric**

**By The Yard**

<b>Mesh for muzzle</b>	<b>Ben textiles inc.</b>	11/18/2020	2	7.68	15.63	<a href="https://www.amazon.com/gp/">https://www.amazon.com/gp/</a>
------------------------	--------------------------	------------	---	------	-------	---

**Component 2**

Desirable Life Bonded Nylon N66 Sewing Thread 700 Yards Size #138 T135 420D/3 for Leather Denim Hand Machine Craft Shoe Bag Repairing Extra Strong Heavy Duty UV Rays Resistant Waterproof

<b>Thread for muzzle</b>	<b>Anminy</b>	11/18/2020	1	5.99	5.99	<a href="https://www.amazon.com/gp/">https://www.amazon.com/gp/</a>
--------------------------	---------------	------------	---	------	------	---

1" Belting/Strapping (2 yd)

<b>Straps for muzzle</b>	<b>Dritz</b>	11/16/2020	1	5.99	5.99	<a href="http://">http://</a>
--------------------------	--------------	------------	---	------	------	-------------------------------

Parachute Buckle

<b>Buckle for muzzle</b>	<b>Dritz</b>	11/16/2020	2	5.99	11.98	<a href="https://">https://</a>
--------------------------	--------------	------------	---	------	-------	---------------------------------

Water-Resistant Closed Cell, Foam Sheet, Polyethylene, 1/2 in, 24 in, 18 in, Charcoal

<b>Foam for inside of muzzle</b>	<b>Grainger Item #5GCR9</b>	11/18/2020	1	9.73	21.85 (shipping included)	<a href="https://www.grainger.com/product/5GCR9?crItem&amp;rfe=5668fb2d0f2e2ccf9712437fe4cfecf75aedc3848ef3592c55141bbf4dfc84ca&amp;gc">https://www.grainger.com/product/5GCR9?crItem&amp;rfe=5668fb2d0f2e2ccf9712437fe4cfecf75aedc3848ef3592c55141bbf4dfc84ca&amp;gc</a>
----------------------------------	-----------------------------	------------	---	------	---------------------------	---

4-Way Stretch Nylon Spandex Matte Tricot | Suitable for Sportswear, Activewear, Swimwear, Dancewear, Yoga Wear, Table Cloth (Black)

<b>Fabric for muzzle</b>	<b>Rex fabrics</b>	11/18/2020	1	14.99	14.99	<a href="https://www.amazon.com/gp/">https://www.amazon.com/gp/</a>
--------------------------	--------------------	------------	---	-------	-------	---

uxcell Acrylic Round Rod,Clear,0.2 inch Diameter 10i inch Length,Solid Plastic PMMA Bar Stick 2pcs	<b>Support rods for muzzle</b>	<b>UXCell</b>	<b>11/25/2020</b>	<b>3</b>	<b>7.99</b>	<b>23.97</b>
---	--	---------------	-------------------	----------	-------------	--------------

<https://www.amazon.com/gp/>

**TOTAL:**

**Conclusions/action items:**

We will reach out to our client for reimbursement on cost.



# Materials Design Matrix

---



# 2020/10/1 - Fabrication Plan

Sydney Appleton - Dec 08, 2020, 9:26 PM CST

**Title: Fabrication Plan**

**Date:** 10/1/2020

**Content by:** Sydney Appleton

**Present:** Sydney Appleton and Alexandria Thao

**Goals:** Create a basic fabrication plan.

**Content:**

**Fabrication Plan**

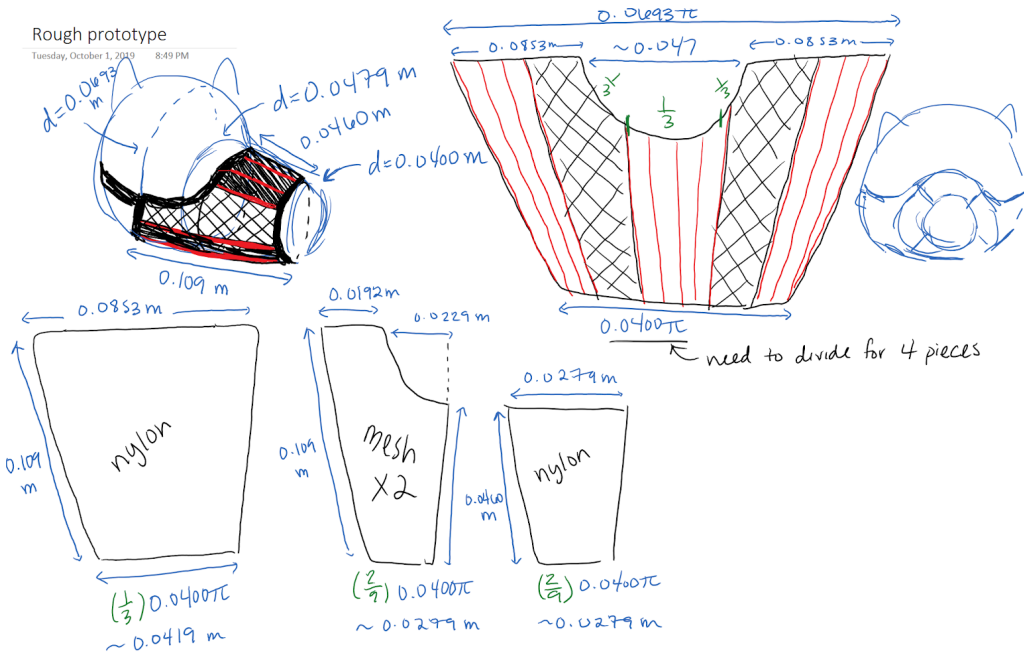

- 4 separate pieces sewn together → 1 bottom nylon piece, 1 top nylon piece, 2 side mesh pieces
- Need to add on few mm to account for muscle, skin, and fur → also need to add extra mm hem allowance

**Where to purchase and prices?**

**Polyamide**

- Sheets available from:
  - midland plastics or fleckface.com (TeamLab suppliers)
  - Shop@UW from Fischer Scientific
- Can be 3D printed at Makerspace using Ultimaker printers → \$0.12 per gram

**Polypropylene**

- Sheets available from:
  - midland plastics or fleckface.com
- Can be 3D printed at Makerspace using Ultimaker printers → \$0.13 per gram

**Aluminum**

- Can buy sheets on Shop@UW from WW Grainger
- Can buy sheets on Shop@UW from MSC Industrial Supply Co.

## Nylon

- Mesh sheets available on (non-Shop@UW):
  - <https://www.fabricwholesaledirect.com/products/power-mesh-fabric?variant=11088926470> (\$3.99/yd)
  - Performance Nylon Spandex Power Mesh Fabric Black at JoAnn's \$8.99/yd (minimum 2 yards)
  - Solid Power Mesh Fabric Nylon Spandex - FWD on Amazon (1 yd - \$6.99)
- Non-Mesh sheets:
  - [Ripstop Nylon Fabric 59" Solids](#)
- Other
  - Nylon straps - [Joann's](#)
  - Buckle - [Joann's](#)
- **Optional** - corset bone casing to insert supports into, no need to make own folds in muzzle
  - Polyester bone casing - \$8.99 from [Amazon](#)

**Conclusions/action items:**

We will use this going forward with fabricating our process.



# FEA Testing Protocol

KATHERINE KONIECZKA - Dec 09, 2020, 10:28 AM CST

**Title:** FEA Testing Protocol

**Date:** 11/28/2020

**Content by:** Kate Konieczka

**Present:**

**Goals:** Develop a plan to accurately test how different affect the stress concentrations in the mandible

**Content:**

1. Use the spline tool in solidworks to create a rough sketch of the mandible
  - To do this you will select Extruded boss/base
  - Select the front plane
  - Select the spline tool
  - Create a rough sketch of the model by going section by setion connecting numerous splines until the sktech is complete
  - Once you are done click exit sketch and it will prompt you to select a thickness for the base. Input 1.5 inches.
2. Make an extruded cut approximately where the M1 tooth would lie.
  - Select extruded cut
  - Click on the front plane of the mandible model
  - Use the line tool to draw on the mandible where you would like the cut to be made
  - Click exit sketch and select the thickness of the cut
  - Select a thickness that is equal to that of the model (1.5 inches)
3. Click on SolidWorks Simulation
4. Select static test
5. Right click on fixture and select fixed geometry.
6. Place fixtures along the back of the mandible at the joint location. The placement of the figures can be seem in the images of the tests attached below.
7. Repeat this two more times so you now have 3 static tests that you can edit.
8. For each test right click external laods and select force
9. Select across the tp of the mandible and set the force to 855N
10. Check total force before saving
12. Leave static 1 as is
13. For the static 2 right click applied load and select forces
14. Select the bottom of the mandible thats directly below the fracture site.
15. Set the force to 855 N and save
16. For static three complete steps 13 - 15 but add the forces across the entire bottom of the mandible and select total force before saving.
17. Right click the name of the model and select the apply/edit material
18. Right clck custom materials and select new material
19. Input the mechanical properties of bone. When finished select save and apply. This will apply the new material to each of the studies.

**Shear Modulus** 3300 N/mm<sup>2</sup>

**Elastic Modulus** 5650 N/mm<sup>2</sup>

<b>Poisson's Ratio</b>	0.62
<b>Mass Density</b>	2000 kg/m <sup>3</sup>
<b>Tensile Strength</b>	53 N/mm <sup>2</sup>
<b>Compressive Strength</b>	65.2 N/mm <sup>2</sup>
<b>Yield Strength</b>	44.1 N/mm <sup>2</sup>

Mechanical properties of bone that should be applied to the model

- 20. Right click mesh and select mesh and run for each of the studies,
- 21. A scale will automatically generate with the stress values seen throughout the mandible.
- 22. Select plot tools ---> probe tool and randomly select 10 points around the fracture for each test and record those values.

**Conclusions/action items:**

In the future the team would like to have a more accurate model of the jaw in solidworks, whether that be the 3D scan or just a more accurate model of the mandible.

KATHERINE KONIECZKA - Dec 09, 2020, 10:19 AM CST

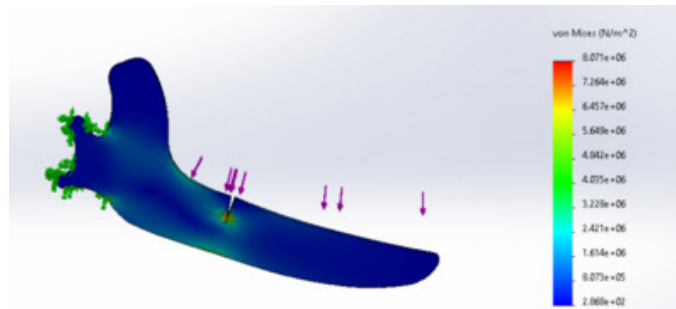

feano\_support\_2\_.PNG(223.6 KB) - [download](#) Screenshots of the placement of fixtures and forces for each of the support types

KATHERINE KONIECZKA - Dec 09, 2020, 10:19 AM CST

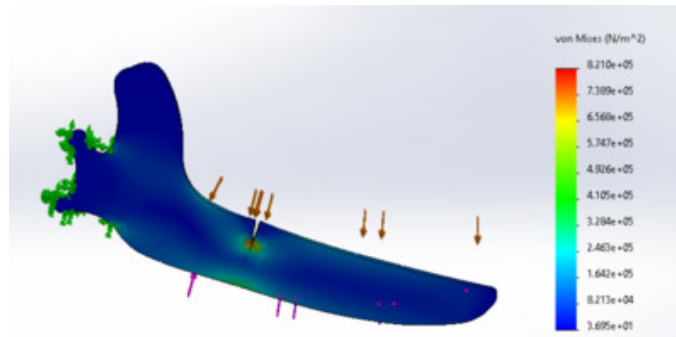

supportfea\_2\_.PNG(190.7 KB) - [download](#) Screenshots of the placement of fixtures and forces for each of the support types

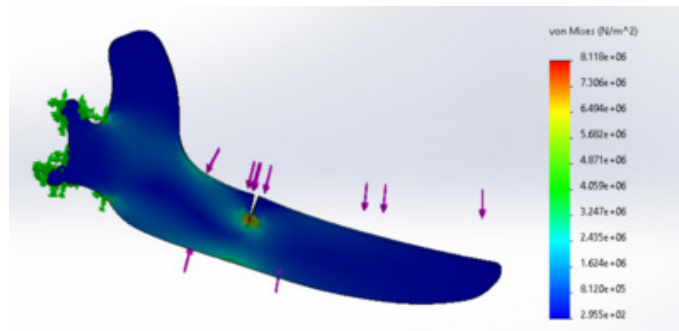

tapefea\_2.PNG(218.1 KB) - [download](#) Screenshots of the placement of fixtures and forces for each of the support types



## 2020/12/1 FEA matlab analysis

Arrington Polman - Dec 08, 2020, 1:21 PM CST

**Title:** Arrington Polman

**Date:** 12/1/2020

**Content by:** Arrington

**Present:** Arrington

**Goals:** Create a matlab script for analysis on FEA results

**Content:**

I began writing a script based on our team meeting last night. We have a solidworks model where we found the stresses for the different support types. I wrote a script initially for the samples we had during our meeting (these are commented out).

**Conclusions/action items:**

I decided that we would want the entire data set, rather than just the summary given in solidworks. Kate will be able to resample tomorrow and we will do analysis on that.

Arrington Polman - Dec 08, 2020, 1:22 PM CST

```

Solidworks FEA analysis
Arrington Polman
BME Design300200
Begin: 12/1/2020
Last Modified: 12/1/2020

close all
clear all

Data of Fracture
none = [];
full = [];
tape = [];
% each is a 3x
none = none./1e6;
full = full./1e6;
tape = tape./1e6;
% putting into MPA

% avg_stress = 4.236e3; % MPa
% avg_full = 2.395e3; % MPa
% avg_tape = 4.161e3; % MPa
%
% max_stress = 1.160e3;
% max_full = 3.603e3;
% max_tape = 9.994e3;
%
% min_stress = 3.197e3;
% min_full = 9.624;
% min_tape = 3.649e3;
%
% n_stress = 10;
% n_full = 10;
% n_tape = 10;

avg_stress = mean(none);
avg_full = mean(full);
avg_tape = mean(tape);

max_stress = max(none);
max_full = max(full);
max_tape = max(tape);

n_stress = length(none);
n_full = length(full);
n_tape = length(tape);

```

[Stats\\_on\\_solidworks.pdf\(543.1 KB\) - download](#) Initial statistics code



## 2020/12/2 Matlab analysis

Arrington Polman - Dec 08, 2020, 1:29 PM CST

**Title:** Finalized Matlab analysis

**Date:** 12/2/2020

**Content by:** Arrington

**Present:** Arrington

**Goals:** Finalize analysis from solidworks data

**Content:**

I built on the initial code by changing to the anova1, since the support was the only variable changing between tests, and placed this before t-testing. I also added in the bonferroni correction to the code, but resulting significance did not change depending on which  $\alpha$  was used.

**Conclusions/action items:**

This code allows us to draw conclusions and we can add it to our report and presentations.

Arrington Polman - Dec 08, 2020, 1:29 PM CST

### Solidworks FEA analysis

Arrington Polman  
BME Design 300/200  
Began: 12/1/2020  
Last edited: 12/2/2020

```

close all
clear all

Loading Data
data = readmatrix('FSK\data.xlsx');

Data of Fracture
sone = data(1:10,4);
full = data(1:10,3);
tape = data(1:10,2);
% write to txt file

sone = sone./1e3;
full = full./1e3;
tape = tape./1e3;
% printing into txt

avg_sone = mean(sone);
avg_sone = 5.148e+01;
avg_full = mean(full);
avg_full = 481.5808;
avg_tape = mean(tape);
avg_tape = 5.4124e+01;

%SD
std_sone = std(sone);
max_sone = 7224;
std_full = std(full);
max_full = 742.5008;
std_tape = std(tape);
max_tape = 7734;

```

FeaSimulationAnalysis12\_2.pdf(132.1 KB) - [download](#) Final Matlab code



KATHERINE KONIECZKA - Dec 08, 2020, 9:34 PM CST

**Title:** Project Design Specifications

**Date:** 9/18/2020

**Content by:** Kate Konieczka

**Present:** All

**Goals:** Develop a well written PDS

**Content:**

Attached below is a copy of our PDS

**Conclusions/action items:**

We will submit this to our advisor and await feedback. This document will also be referenced throughout the design process.

KATHERINE KONIECZKA - Dec 08, 2020, 9:34 PM CST

**VetMed: Affordable Muzzle to Assist in Mandibular Fracture Repair in Dogs- BME 300/200**

Product Design Specifications  
September 18, 2020

**Client:** Graham Thatcher  
**Team:** Arington Polina arpolina@vtic.edu  
Kate Konieczka kkonieczka@vtic.edu  
Sydney Applbaum sappbaum2@vtic.edu  
Matthew Wroblewski mchwroblewski@vtic.edu  
Jakob Krass jakkrass@vtic.edu  
Alexandra Thao athao26@vtic.edu

**Function:** Our client is seeking an improvement in current muzzle techniques during pre- and post-surgery stages for mandibular fracture repair in dogs. The muzzle could also be used as a cheaper alternative to the surgery. Canine mandibular fractures most commonly occur at the M1 tooth, as a result of the large volume of the tooth compared to mandible [1]. Existing methods of repair require surgery and several anesthetic events, resulting in a high-cost to the patient owner. A suggested way to relieve pain before and after surgery, and a possible cheaper solution, is using a muzzle to support the mandible. The bite force of this tooth ranges from 620.33-1,091.1 N [2], and displaces that force into the jaw. The team is tasked with designing and validating a muzzle that evenly distributes the bite force applied to the mandible away from the fracture site, without completely restricting movement.

**Client requirements:** The client is expecting the following:

- The muzzle to evenly distribute force throughout the mandible that is applied by the muscles and biting.
- Must properly support the fractured mandible.
- Prevent stress concentrations or displacement near the existing fracture site at the M1 tooth.
- Create a small, medium, and large size, and be adjustable to fit dogs between sizes.
- A model to validate a decrease in stress compared to existing taped muzzle options.

[VetMed\\_AffordableMuzzle\\_PDS-Version1\\_1\\_.pdf\(115.4 KB\) - download](#)



 **Preliminary Report**

Sydney Appleton - Dec 09, 2020, 8:17 AM CST

**Title:** Preliminary Report

**Date:** 10/7/2020

**Content by:** Kate Konieczka

**Present:** All

**Goals:** Put together the preliminary report that includes all the work the team has accomplished thus far.

**Content:**

A copy of our preliminary report is attached below.

**Conclusions/action items:**

We will submit this to our advisor and wait for feedback.

KATHERINE KONIECZKA - Dec 08, 2020, 9:30 PM CST



canine\_muzzle-preliminary\_report\_1\_.pdf(1012.6 KB) - [download](#)



## 2020/9/6- Mandible Fractures in Dogs

Arrington Polman - Sep 06, 2020, 8:06 PM CDT

**Title:** Initial relevant journal searches- Mandible fractures in dogs

**Date:** 9/6/2020

**Content by:** Arrington Polman

**Present:** Arrington Polman

**Goals:** Learn more about the background for our project

**Content:**

Project Objective: Create a nylon muzzle that provides greater support than tape muzzles.

Description: Canine mandible fractures commonly occur in the mandibular carnassial tooth (M1; seen in Figure 3). Relatively large volume of M1 results in increased weakness in the mandible. These fractures are stabilized through several orthopedic repair techniques, which occur at high financial cost for the dog owners [1-2]. Post-procedure, a recommended and relatively inexpensive way to support the lower jaw has been through a tape muzzle. They can easily be made with bandaging tape, and can easily changed by the owner when dirtied. It is placed on by surrounding the snout with a 1.5cm opening, and adhesive tape side out, then back over with another piece of tape, with adhesive sides together. Then, the same procedure around the back of the head [3]. An example can be seen below.



Figure 1: Tape Muzzle

There are design flaws with the current method; the jaw does not need to be rigidly fixed, as it does not bear a lot of weight. Also, the lack of area of tape along the bottom jaw creates a pivot point and an increase in stress at the fracture site. This will lead to delayed healing and oral pain. [4]

An alternative to the tape muzzle is a cloth, nylon, or mesh based sling muzzle. These types of muzzles are more likely to cradle along the bottom mandible, rather than support at one point. These can be slid off after unbuckling the strap that goes around the back of the head. A picture of these can also be seen below.



Figure 2: Sling Muzzle

Design Requirements: Must limit stress concentration at any one point along the mandible, must allow 0.5-1.0 (max of 1.5) cm for eating soft food and drinking water.

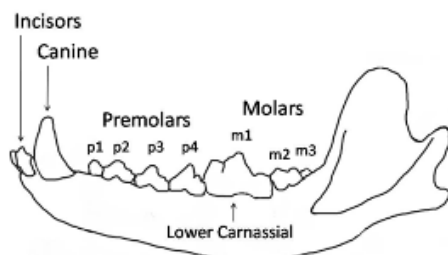

Figure 3: Canine Lower Mandible Dental Anatomy [5]

**References:**[1] Kitshoff AM, de Rooster H, Ferreira SM, Steenkamp G. A retrospective study of 109 dogs with mandibular fractures. Vet Comp Orthop Traumatol. 2013;26(1):1-5.

[2] Umphlet R, Johnson A. Mandibular fractures in the dog, a retrospective study of 157 cases. Vet Surg. 1990; 19: 272-275.

[3] Withrow, S.J. (1981). Taping of the mandible in treatment of mandibular fractures. J. Am. Anim. Hosp. Assoc. 17: 27.

[4] Manfra Marretta, S., Schrader, S.C., and Matthiesen, D.T. (1990). Problems associated with the management and treatment of jaw fractures. Probl. Vet. Med. Surg. Dent. 2: 220.

[5] W. Harris, "Wolf mandible diagram." 08-May-2016.

**Conclusions/action items:**

- We already have the design that we want to be able to test, so we will have to come up with a way to best test the stresses experienced when wearing each type of muzzle.

- The client will be providing us with commercially available muzzles for deconstruction to be able to use for prototyping.

- I will next look into ways to quantify the amount of support that a sling type muzzle would have over a tape muzzle.



## 2020/9/12 Dog bite and bone research

---

Arrington Polman - Oct 07, 2020, 7:33 AM CDT

**Title:** Canine Bone property research

**Date:** 9/12/2020

**Content by:** Arrington

**Present:** Arrington

**Goals:** Find ideal pressure for canine bone healing

**Content:**

It would be useful for our team to be able to tell the maximum stress at the fracture point that will be conducive to healing. This will allow us to have numerical values during our testing comparisons, instead of comparing to the tape muzzle.

C. Kunz, N. Adolphs, P. Büscher, B. Hammer, and B. Rahn, "Mineralization and mechanical properties of the canine mandible distraction wound following acute molding," *International Journal of Oral and Maxillofacial Surgery*, vol. 35, no. 9, pp. 822–827, 2006.

- This study investigated the regeneration of the mandible after surgery.
- Canines were split into groups based on their fracture pattern and angle of fracture.
- After 6 weeks, 25% of specimens had mechanical stiffness of at least 90% of an unfractured mandible.
  - o The reference was given as a 223.5 N/mm occlusal load & 251.2 N/mm basal load.
- Regardless of fracture pattern, each was not significantly different from unfractured after 13 weeks.
  - o These were surgically repaired, may not be the same with just a muzzle.

Kim, S., Arzi, B., Garcia, T. and Verstraete, F. (2018). Bite Forces and Their Measurement in Dog and Cats. *Frontiers in Veterinary Science*, 5.

-

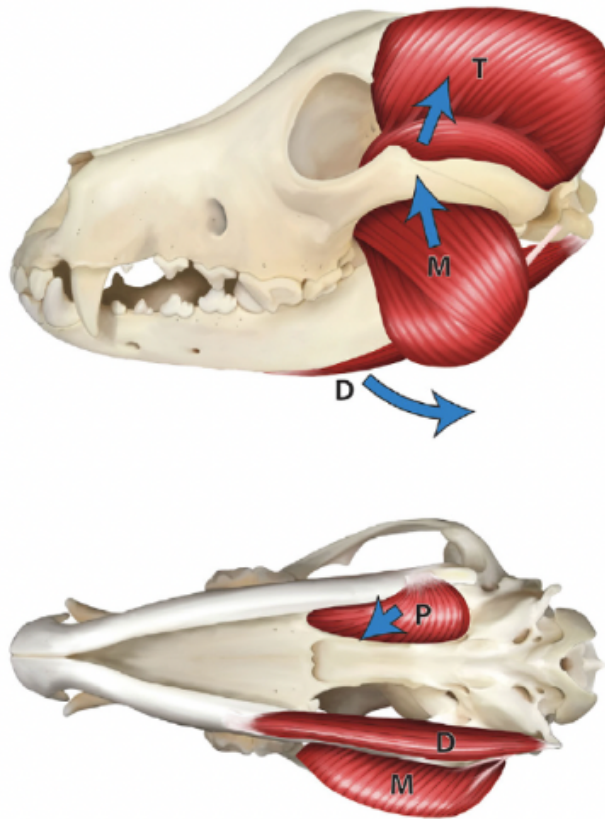

Using this study to find bite forces in the mandible

- This image shows muscles causing biting and opening of the mouth. These muscles cause the bite force: Masseter and temporal, and opening: digastric.

-

**TABLE 1** | Studies on the bite force measurement/estimation in dogs and cats.

Animal	Measured/ estimated location	Bite force (Newton, N)	Measurement/ estimation method	
Dog	Not specified	13–1,394	Measured by chewing transducer rolled with the rawhide (22)	
	Canine teeth	147–926	Maximum bite force measurement by electronic stimulations (26)	
	Molar teeth	574–3,417		
	Canine teeth		300*	Bite force estimation using equations of Kiltie (27) Thomason (28) Kiltie (26) (adjusted) Thomason (26) (adjusted)
			340*	
			571*	
			588*	
	Molar teeth		755*	Kiltie (27) Thomason (28) Kiltie (26) (adjusted) Thomason (26) (adjusted)
849*				
1,949*				
2,036*				
Canine teeth Carnassial teeth		351.5*	Bite force estimation using Thomason's equation (29)	
		549.8*		
Canine teeth Carnassial teeth		231.99–511.80*	Bite force estimation using finite element analysis (35)	
		620.33–1,091.1 <sup>b</sup>		

This table displays bite forces for the dog. The FEA analysis will probably be the most accurate for what we are doing.

**Conclusions/action items:**

I now have some additional background on the problem that we are facing. This information will be useful in building our product design specifications.



## 2020/11/11 Mechanics of bone formation

---

Arrington Polman - Dec 09, 2020, 8:55 AM CST

**Title:** mechanics of bone healing

**Date:** 11/11/2020

**Content by:** Arrington

**Present:** Arrington

**Goals:** Learn more about the bone healing process

**Content:**

In a previous client meeting, he had mentioned that a design would not work because it would partially separate the fracture and limit healing. I wanted to learn more about the process in case we get any questions about it.

Prerequisites for bone healing:

- Blood supply
- mechanical stability - this is the method that were increasing in our design\

Bone formation

- Long bone will grow together in length, closing the fracture
- Stability promotes revascularization

Importance of stability

- slight load stimulates healing
  - we cannot completely remove the stress
- Stability is required to limit excess deformation of the fracture site
- over-stabilization however will limit growth of periosteal (hard callus) and increases risk for re-fracture

Stages of healing

- Inflammation
- Repair
- Remodelling

Direct healing is quicker than gap healing, since the two ends are in contact and do not need to have growth towards each other.

Source: T. Timothy McHenry, J. Scott Broderick, "Biology of Bone Repair," 11-Nov-2020.

**Conclusions/action items:**

This research gives me a better understanding of how our design assists in healing the fracture.



## 2020/9/11 Computer Model Research

Arrington Polman - Oct 06, 2020, 7:45 PM CDT

**Title:** Computer modeling mandible research

**Date:** 9/11/2020

**Content by:** Arrington

**Present:** Arrington

**Goals:** Find a model that can be loaded to solidworks for FEA

**Content:**

In our client and advisor meetings, we talked about putting a model of a canine mandible into solidworks. This would be useful so that we can add bite forces from the masseter onto the teeth and find stress concentrations found in the jaw through FEA. Hopefully, we could then combine with a model for our designs, and redo the test to see how they compare.

I started by looking into solidworks forums, but didn't find anything worth trying to use. I then stumbled upon a bme design project from fall 2019 that developed a reconstructive element for a jaw fracture. They had the same client as we do. This project used STL files from CT scans to load meshes for FEA. They used different software, which may be a concern. They also made simplified models for solidworks, and it is clear that the m1 tooth would have a stress concentration in their models.

It would be interesting to see if we could get this model and look into software for FEA, or if we will need CT scans to build our own.

**Conclusions/action items:**

We will email our client and the leader of the design team last year to see how they went about getting meshes for the mandible.

Arrington Polman - Oct 06, 2020, 7:51 PM CDT



**Screen\_Shot\_2020-10-06\_at\_7.50.43\_PM.png(106.7 KB) - [download](#)** Canine mandibular model and finite element analysis in solidworks, done by past bme design group. FEA was conducted on simplified versions of the model.

Arrington Polman - Oct 06, 2020, 7:51 PM CDT



**Screen\_Shot\_2020-10-06\_at\_7.50.29\_PM.png(85.4 KB) - [download](#)** Canine mandibular model and finite element analysis in solidworks, done by past bme design group. FEA was conducted on simplified versions of the model.



Arrington Polman - Oct 06, 2020, 7:51 PM CDT

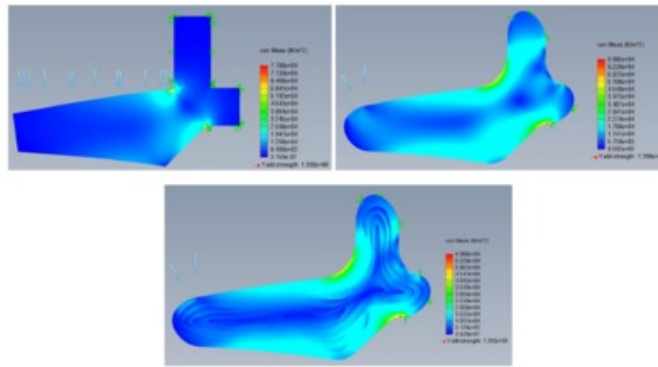

Screen\_Shot\_2020-10-06\_at\_7.48.24\_PM.png(414.5 KB) - [download](#) Canine mandibular model and finite element analysis in solidworks, done by past bme design group. FEA was conducted on simplified versions of the model.

Arrington Polman - Oct 06, 2020, 7:53 PM CDT

Source: W. Wightman, L. Richmond, Y. Kim, C. Van Horn, and K. Gasper, "VetMed: Design and Mechanical Analysis of Patient-Specific Mandibular Reconstruction Implants," *UW- Madison, BME Design 200/300*, Dec. 2019.



## 2020/9/27 Muzzle dimensions

Arrington Polman - Oct 07, 2020, 8:58 AM CDT

**Title:** Muzzle dimensions

**Date:** 9/27/2020

**Content by:** Arrington

**Present:** Arrington

**Goals:** Find dimensions of a muzzle that can be used for our design

**Content:**

I spent some time looking into sizes of dimensions of commercially available muzzles. I found one muzzle with a chart that I think could be used to make our small, medium, and large sizes. We would have to update to make our specific muzzle design.

Size	Snout Circumference	Depth: Top of Muzzle	Depth: Bottom of Muzzle	Dog Breed Suggestions
XXS	4.25-in	0.75-in	2.5-in	Chihuahua, Pomeranian, Yorkshire Terrier
XS	5-in	0.75-in	2.7-in	Jack Russell Terrier, Miniature Schnauzer, Westie
S	6-in	1.75-in	4.25-in	Beagle, Cocker Spaniel, Siberian Husky
M	7.25-in	2-in	4-in	German Shepherd, Golden & Labrador Retrievers
M (SHORT-SNOOUT/3XL)	11-in	1-in	3.1-in	American Bulldog, Boxer, Chow Chow
L	8.5-in	2.1-in	5-in	Newfoundland, Rottweiler, Saint Bernard
XL	9.5-in	2.5-in	5.25-in	Great Dane, Irish Wolfhound, Mastiff

**Conclusions/action items:**

We will use these dimensions to design our mesh muzzle, and start creating a fabrication plan.



## 2020/10/17 Fabric Materials

---

Arrington Polman - Dec 09, 2020, 7:52 AM CST

**Title:** Fabric material research

**Date:** 10/17/2020

**Content by:** Arrington Polman

**Present:** Arrington, Alex

**Goals:** Learn about the different fabric types from Alex

**Content:**

Beginning with nylon fabric

- Most commonly used for commercially available dog muzzles
- Composed of synthetic fibers, that are strong and elastic
  - stronger than polyester
- Tough and won't tear easily
- Easy to wash
- No chemical reactivity

Alex also detailed several mechanical properties of the fabric, which can be found in her notes.

Next was Polyester

- increased rigidity and heat resistance
- but maintains flexibility
- wear resistant, tough to rip

Cotton

- Absorbs water
- easy to clean
- will wrinkle and shrink (like a cotton t-shirt)
- also durable and strong

**Conclusions/action items:**

Using this information, we will evaluate a design matrix to find the best material for the muzzle.



## 2020/10/17 Support rod material research

---

Arrington Polman - Dec 09, 2020, 8:03 AM CST

**Title:** Support rod material research

**Date:** 10/17/2020

**Content by:** Arrington

**Present:** Arrington, alex, sydney

**Goals:** Learn about different material possibilities for the support rods

**Content:**

We discussed properties of the materials that may be used as support rods.

We began with polypropylene.

- Semi-rigid
- Not chemically reactive
- high toughness
- high fatigue resistance
- available at the makerspace

Next was aluminum

- A much stronger material, resists straining
  - probably too strong
- electrical and thermal conductivity
- non-toxic

I also looked at acrylic

- Its durable
- large temperature range use, within our working environment
- its easily machinable
- strong and stiff

Acrylic source:

V. I. Plastics, *Vanderveer Industrial Plastics*. [Online]. Available: <https://www.vanderveerplastics.com/compare-materials.html?sel1=acrylic>. [Accessed: 09-Dec-2020].

**Conclusions/action items:**

We will use this information for evaluating our materials design matrix.



## 2020/9/22 Velcro & Clip Idea

Arrington Polman - Oct 07, 2020, 7:47 AM CDT

**Title:** Velcro & Clip Design

**Date:** 9/22/2020

**Content by:** Arrington

**Present:** Arrington

**Goals:** Make an initial design to share with the team

**Content:**

My goal for this design was to make the circumference of the muzzle, and strap around the head as adjustable as possible, so that it could fit dogs securely. I also included rods along the bottom, hopefully to go on each side of the jaw for support, like a splint.

**Conclusions/action items:**

I will share this design with my team when we meet.

Arrington Polman - Oct 07, 2020, 7:48 AM CDT

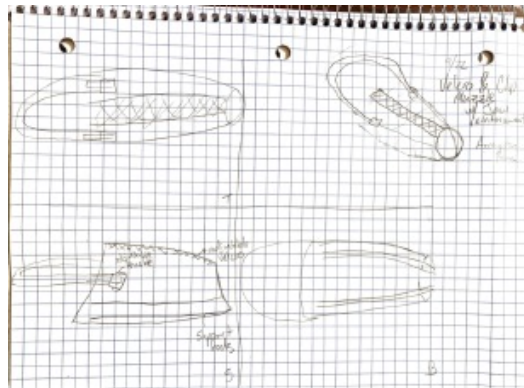

**Muzzle\_design.pdf(1.3 MB) - download** Velcro & Clip muzzle with jaw reinforcement



## 2020/9/27 Detailed mesh design

Arrington Polman - Oct 07, 2020, 8:02 AM CDT

**Title:** Mesh design with dimensions

**Date:** 9/27/2020

**Content by:** Arrington Polman

**Present:** Arrington

**Goals:** Create an adjusted mesh design with dimensions

**Content:**

I wanted to add some dimensions to the mesh design, another step closer to building a prototype. Dimensions are from previous research into sizes of commercially available muzzles. Another aspect is the change in the top strap, I think this may be difficult to put on the dog, so I'm going to talk with my team about it.

**Conclusions/action items:**

I will share this design with my team.

Arrington Polman - Oct 07, 2020, 8:03 AM CDT

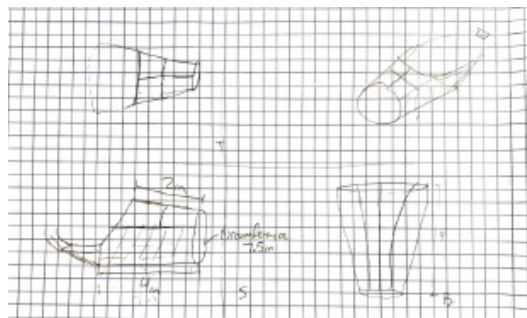

**Meshw\_sizes.pdf(1010.6 KB) - [download](#)** Mesh design with top, bottom, and snout circumference.



## 2020/10/6 Cadaver Measurements

---

Arrington Polman - Dec 07, 2020, 8:44 AM CST

**Title:** Measuring Cadaver head to improve design

**Date:** 10/6/2020

**Content by:** Arrington

**Present:** Arrington

**Goals:** Measure the skull of the head our client gave us to improve our design and create calculations.

**Content:**

Below are picture of the canine cadaver head. Measurements were taken, using a basic ruler, for the entire jaw portion, the carnassial tooth, each molar, and the canine tooth. Also estimated was the cross-sectional area (A) at the jaw below the carnassial tooth. The top of the snout was also measured, and that dimension added to the fabrication design plan.

**Conclusions/action items:**

Using these measurements, we intend to create an estimate of the force at the fracture site under various support conditions. We have also used these measurements to create our medium sized muzzle design.

---

Arrington Polman - Dec 07, 2020, 8:41 AM CST



Full\_head.jpg(92.4 KB) - [download](#)

Arrington Polman - Dec 07, 2020, 8:42 AM CST

Measurement\_locations.jpg(92.8 KB) - [download](#)

Arrington Polman - Dec 07, 2020, 8:45 AM CST

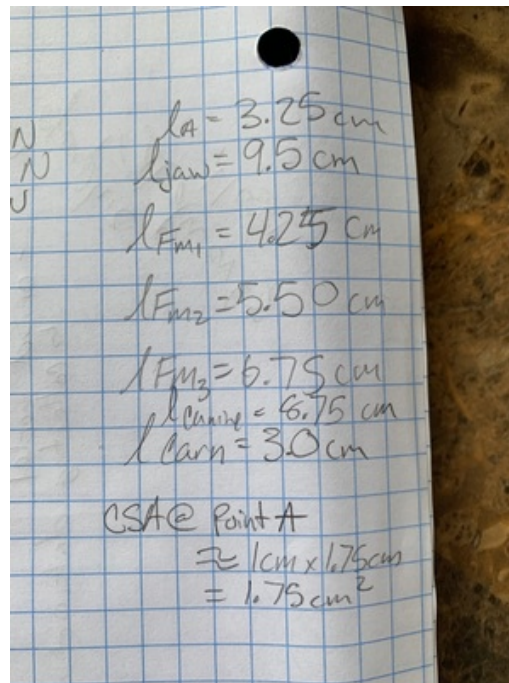
Measurements.jpg(183.9 KB) - [download](#) Dimensions are the distance from the proximal end of jaw (marked in image above) to the given location





## 2020/10/4 FEA softwares

---

Arrington Polman - Dec 06, 2020, 2:39 PM CST

**Title:** FEA software options

**Date:** 10/4/2020

**Content by:** Arrington Polman

**Present:** Arrington

**Goals:** Look at FEA software options

**Content:**

Our client mentioned previous design teams struggling with conducting FEA in solidworks, so I decided to look into other options. He mentioned using meshmixer and 3-matic.

After some research, I downloaded meshmixer to my computer, and I believe it will be useful for cleaning up and isolating the stl files from our 3d scans. 3-Matic and many other cad systems are capable of doing fea, but are expensive and we do not have access to them.

**Conclusions/action items:**

We will need to begin creating a solidworks model of our jaw, and also Kate and I set up and email to go into the makerspace and 3d scan the dog mandible.



## 2020/10/28 Solidworks Reduction attempts

---

Arrington Polman - Dec 09, 2020, 8:17 AM CST

**Title:** Solidworks reduction of files attempts

**Date:** 10/28/2020

**Content by:** Arrington

**Present:** Arrington, Kate, Matt

**Goals:** Reduce file size of jaw scan to run FEA

**Content:**

I met with Kate and Matt to go over what they have been working on for the solidworks files, and what we should try next.

They have been able to take the raw stl files and import them into solidworks using specific settings. They were importing as solids, rather than a mesh, as previously done. The problem with this is that when the mesh solidifies, if there are any remaining holes in the scan, it creates multiple parts of a solid, rather than one large part.

We went through meshmixer and solidworks to try to fill in the holes and reduce the file. There had to be a balance between reducing the file quality and losing geometry, but finding a workable file.

Eventually we were able to get a file that we believed was completely filled in, but when added to an FEA simulation, the computer stalled.

Some of the original and reduced files can be found below.

**Conclusions/action items:**

We will want to load these files to computers that are able to do increased processing in ECB, and maybe they will be able to run.

---

Arrington Polman - Dec 09, 2020, 8:19 AM CST



**jawsolid.stl(2.1 MB)** - [download](#) Solid, and reduced jaw file

---

Arrington Polman - Dec 09, 2020, 8:19 AM CST



**RedJaw2.stl(281.9 KB)** - [download](#) Solid, and reduced jaw file



## 2020/11/17 Blender CAD intro

Arrington Polman - Dec 08, 2020, 10:12 AM CST

**Title:** Blender intro to design muzzle

**Date:** 11/17/2020

**Content by:** Arrington

**Present:** Arrington

**Goals:** Create a computer model for the muzzle

**Content:**

Upon previous feedback, we've been told that we should have a computer aided design of our prototype, rather than showing a hand drawn model. I began by starting in solidworks, yet this was quickly decided I couldn't use. Using a mac with solidworks is slow and it is difficult to create the specific shapes. Given the experience we've had with stl files, I decided to look into other forms of cad. I looked into meshmixer, meshlab, valentina, and blender. I eventually decided on blender because it was by far the most used, and was the easiest for strictly 3d modeling.

I found a youtube intro tutorial video and began by applying those principles to the muzzle. I created a similar shape to the muzzle and began adjusting dimensions to fit an existing dog mesh.

**Conclusions/action items:**

Future goals are to refine the shape of muzzle head to better fit the head, add a back strap, support rods, and color before rendering the image.

Arrington Polman - Dec 08, 2020, 10:13 AM CST

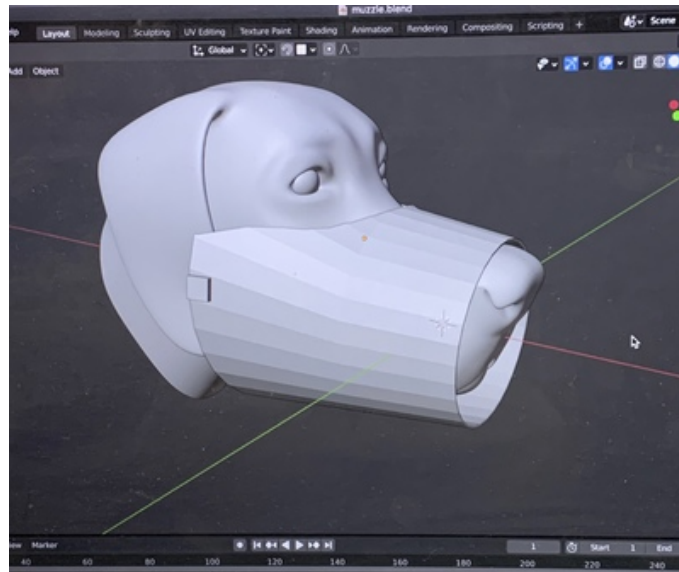

IMG\_5475.jpg(792.4 KB) - [download](#) Initial images of the muzzle design in blender.

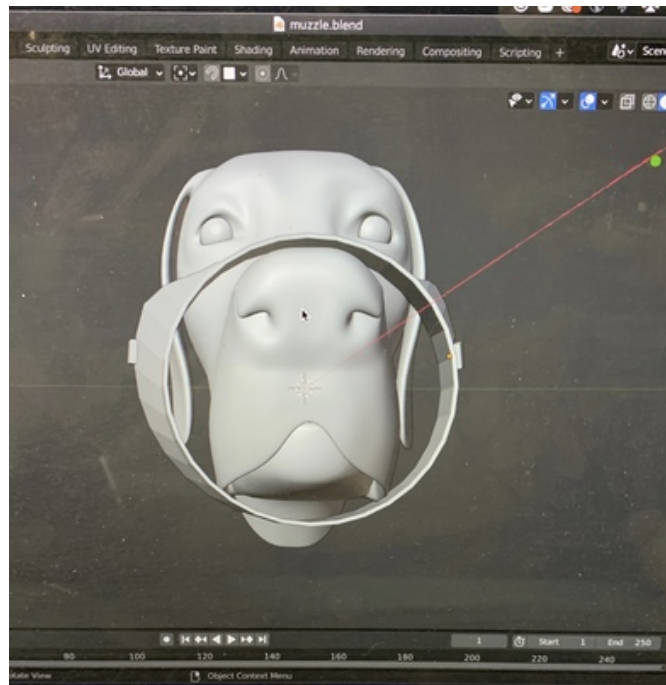

**IMG\_5476.jpg(1.3 MB) - download** Initial images of the muzzle design in blender.

Youtube tutorial video for designing in blender can be found at: [https://m.youtube.com/watch?v=NyJWoyVx\\_XI&list=PLjEaolNr3zgeq0u2MzVgAaHEBt--xLB6U&index=1](https://m.youtube.com/watch?v=NyJWoyVx_XI&list=PLjEaolNr3zgeq0u2MzVgAaHEBt--xLB6U&index=1)

Dog head can be found at: <https://www.turbosquid.com/3d-models/free-obj-model-dog-head/981463>



## 2020/11/19 CAD Fitting

Arrington Polman - Dec 08, 2020, 12:46 PM CST

**Title:** Better fitting of CAD model

**Date:** 11/19/2020

**Content by:** Arrington

**Present:** Arrington

**Goals:** Better fit the CAD design to the dog head

**Content:**

The previous model follows exact dimensions from our fabrication plan, is not adjustable, and it is unknown the size of the dog head. Since for this model will be for presentation, I began closely fitting the muzzle to the dog. I added a back-strap and buckles to the muzzle and wrapped around the dogs head. I next went around and smoothed around the edges and made sure the head part did not poke through the muzzle. I then began adding color and texture to the muzzle.

**Conclusions/action items:**

I will next add the support rods, cut a mesh in the side panel, and make the dog head look more realistic.

Arrington Polman - Dec 08, 2020, 12:46 PM CST



IMG\_5489.jpg(78.6 KB) - [download](#) CAD model, as of 11/19



## 2020/11/29 Finishing Model

---

Arrington Polman - Dec 08, 2020, 12:52 PM CST

**Title:** Finishing Model

**Date:** 11/29/2020

**Content by:** Arrington

**Present:** Arrington

**Goals:** Finalize the CAD Model

**Content:**

I began by adding in support rods along the top and bottom of the muzzle design. I left them clear, and only half sunk into the muzzle, so that they could be easily seen by a viewer.

I next wanted to cut a mesh on the side panels, however, when running a repeated pattern, the computer crashed without completing the operation. We will need to note that the sides will be made of a breathable mesh rather than solid.

Lastly, I wanted to add fur and change the eyes of the dog. However, after getting preliminary progress into the fur work, I realized it would be more trouble than its worth.

**Conclusions/action items:**

I will share this final design with my group, add it to presentations, and focus more on solidworks assistance.

---

Arrington Polman - Dec 08, 2020, 12:52 PM CST



Screen\_Shot\_2020-11-29\_at\_9.05.17\_PM.png(1.6 MB) - [download](#) Final CAD for the muzzle.



## 2020/11/11 ECB Solidworks attempts

Arrington Polman - Dec 09, 2020, 8:27 AM CST

**Title:** ECB Solidworks

**Date:** 11/11/2020

**Content by:** Arrington

**Present:** Arrington, Kate

**Goals:** Run FEA simulation on reduced files at ECB

**Content:**

Kate and I were able to go to an in person lab to run FEA on a larger computer. We believe it might be some kind of processing issue on our laptops that a true desktop will be better at.

We began by downloading all of the part files and adding them into solidworks. When the first reduced model that we have also stalled, we used meshmixer to again reduce the file to a simpler model (seen below). When this new reduced2 model was loaded in, the simulation was able to process, however it gave us an error message. We attempted to go through the different causes of the error, but we were unable to fix the model completely.

**Conclusions/action items:**

Our final deliverables is fast approaching, and we have spent a lot of time working on this model. However, from here until the end of the semester, it would be best to focus on creating our own solidworks part designed after a simplified model. This was we can begin running FEA on that part, and possibly include a cut at the fracture.

Arrington Polman - Dec 09, 2020, 8:28 AM CST



**ReducedJaw2.stl(58 KB) - [download](#)** Reduced jaw file; ran but gave errors.

Arrington Polman - Dec 09, 2020, 8:31 AM CST

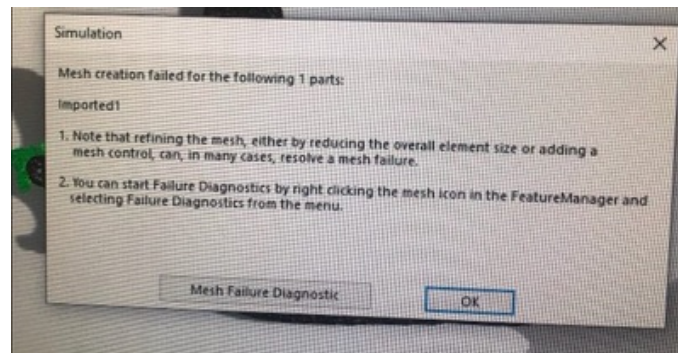

**Screenshot.jpg(137 KB) - [download](#)** Error message while running FEA



# 2020/10/15 FBD and Calculations for supports

Arrington Polman - Dec 07, 2020, 8:59 AM CST

**Title:** Arrington

**Date:** 10/15/2020

**Content by:** Arrington

**Present:** Arrington

**Goals:** Use measurements to create fbd of stress at the fracture sites

**Content:**

By simplifying the jaw as a simple beam, I created free body diagrams for the jaw. I used measurements from hand measuring the cadaver from our client, and for bite forces, I used the average from Kim S. et al. for dog bite forces.

I was able to create shear and moment diagrams for the fbd with no support, and find the shear and moment at just before the masseter pulls.

**Conclusions/action items:**

I will return to these calculations to determine the shear and moment at the fracture site, and conduct the calculations for the other two support types.

Arrington Polman - Dec 07, 2020, 9:01 AM CST

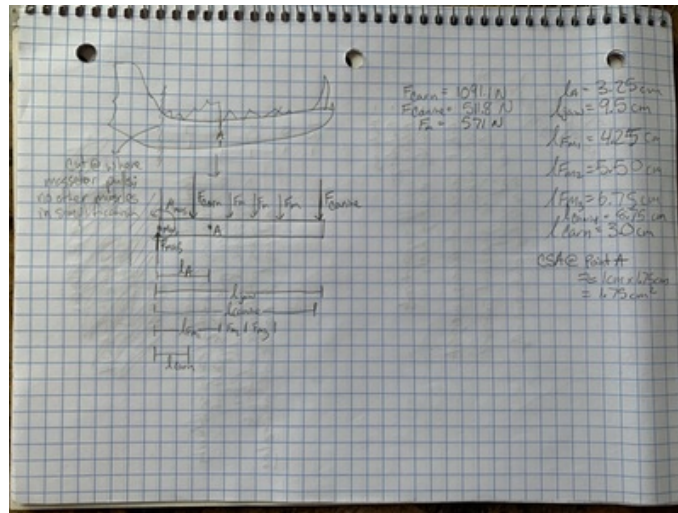

no\_support\_fbd.jpg(116 KB) - [download](#)



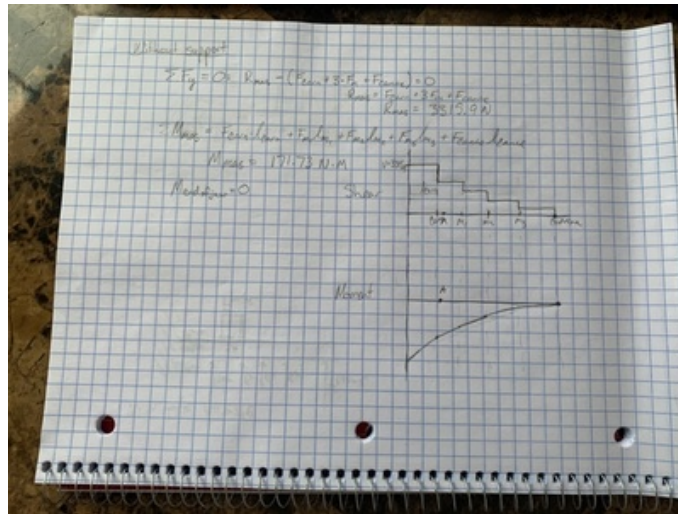

No\_support\_calcs.jpg(117.6 KB) - [download](#)

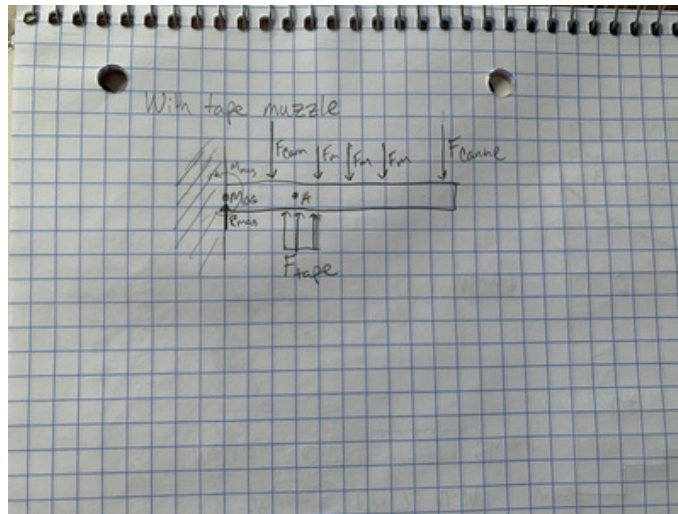

Tape\_support\_fbd.jpg(104.6 KB) - [download](#)

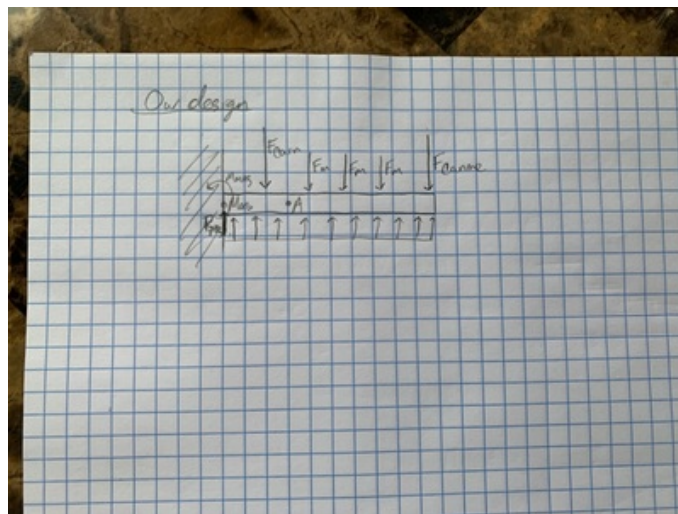

Full\_support\_fbd.jpg(110.6 KB) - [download](#)



# 2020/10/18 Hand calculations of stress at fracture

Arrington Polman - Dec 07, 2020, 9:26 AM CST

**Title:** Hand Calculations of stress on jaw

**Date:** 10/18/2020

**Content by:** Arrington

**Present:** Arrington

**Goals:** Determine value for stress at fracture for support types

**Content:**

I began by transferring fbds and initial shear moment diagrams to my ipad.

On the no support, I took a cut at the fracture (A). I determined the shear and bending moment at A, based on the fbd. I then approximated the stress at the fracture. I calculated a stress value that is very unreasonable for bone, so this must be redone.

For the tape and full support, I am worried that the forces at A will be statically indeterminant. Without knowing the exact amount of reaction force from each support type, there are too many unknowns for the number of equations.

**Conclusions/action items:**

I will return to these equations to figure out where I went wrong in the no support calculations, and review mechanics of materials notes to find options for determining force in the other two conditions.

Arrington Polman - Dec 08, 2020, 8:17 AM CST

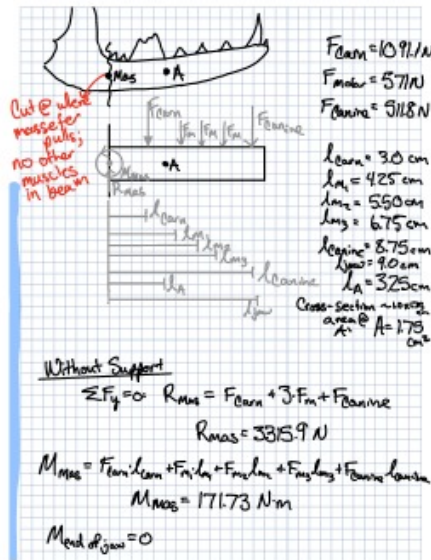



# 2020/10/25 Adding reaction force to hand calculation

Arrington Polman - Dec 08, 2020, 8:32 AM CST

**Title:** Adding support forces to calculations

**Date:** 10/25/2020

**Content by:** Arrington

**Present:** Arrington

**Goals:** Add a reaction force for the tape and full design

**Content:**

After talking with my group, we decided for the simplicity of the hand calculations, it would be okay to estimate a reaction force equal and opposite to the bite forces above. This creates beam models that are determinant.

I also recognized that in my previous calculation for stress without support, I converted from centimeters to meters incorrectly. This change is denoted in red.

**Conclusions/action items:**

I will share these results with out team, and continue to work on solidworks fea to see if we get similar results.

Arrington Polman - Dec 08, 2020, 8:55 AM CST

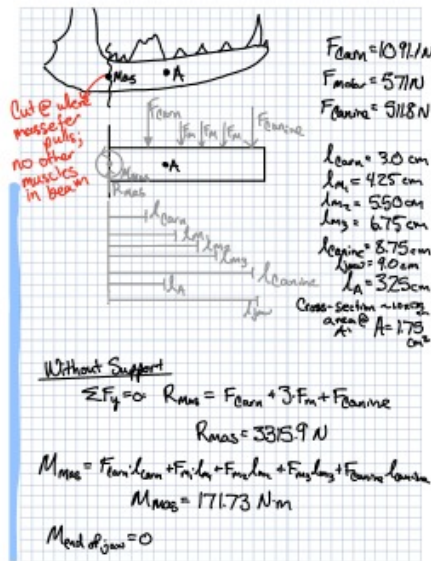

Proof\_of\_concept\_12.pdf(4 MB) - [download](#) Simplified stress calculations for bite force of mandible of given supports.

**Additional Conclusions:**

To summarize findings: A is the fracture site under M1 tooth

<b>Support type</b>	<b>Shear @ A (N)</b>	<b>Moment @ A (Nm)</b>	<b>Stress @ A (MPa)</b>
No support	2224.8	6.669	74.66
Tape	566.85	45.98	51.46
Full	106.3	5.785	6.48



## 2020/11/22 Makerspace Rod Consultation

---

Arrington Polman - Dec 09, 2020, 8:36 AM CST

**Title:** Makerspace Rod Consultation

**Date:** 11/22/2020

**Content by:** Arrington

**Present:** Arrington

**Goals:** Share files to 3d print support rods

**Content:**

My team and I originally had the intention of sharing cylinder models with the makerspace staff and having them 3d print polypropylene rods. However, during our consultation, it was recommended that we just order acrylic rods online. In hindsight, this would have been a much more efficient choice from the beginning. We would not have to wait for a meeting, create a part file, wait for it to print, and it can be shipped directly to us.

**Conclusions/action items:**

We will order rods that fit our support diameter dimension (0.5cm) and then cut them to fit our design.

---

Arrington Polman - Dec 09, 2020, 8:37 AM CST



[long\\_half\\_cm\\_1\\_STL\(7.5 KB\)](#) - [download](#) Size of rod that our part will be trimmed down to before adding to the muzzle.



Arrington Polman - Jan 23, 2020, 4:08 PM CST



Picture\_of\_COE\_Green\_Shop\_Permit.jpg(27.1 KB) - [download](#)

Comments

**Arrington Polman**

Jan 23, 2020 @04:08 PM CST

COE Green Shop Permit



# Biosafety, Responsible Conduct of Research, Human Subjects Basics

Arrington Polman - Apr 08, 2020, 2:30 PM CDT

## University of Wisconsin-Madison

This certifies that ARRINGTON POLMAN has completed training for the following course(s):

Course Name	Curriculum or Quiz Name	Completion Date	Expiration Date
BIOSAFETY REQUIRED TRAINING	BIOSAFETY REQUIRED TRAINING QUIZ	3/21/2020	
RESPONSIBLE CONDUCT OF RESEARCH	RCR CERTIFICATION	8/1/2018	
UW BIOMEDICAL COURSE	BASIC/REFRESHER COURSE - HUMAN SUBJECTS RESEARCH	9/28/2019	9/27/2022

Data Effective: Sun Mar 22 9:59:12 2020  
Report Generated: Sun Mar 22 11:24:41 2020

[ArringtonPolmanTrainings.png\(104.2 KB\) - download](#)



## 2020/09/09 - Mandibular Fractures in Dogs

KATHERINE KONIECZKA - Oct 07, 2020, 1:08 PM CDT

**Title:** Mandibular Fractures in Dogs Research (Anatomy)

**Date:** 9/9/2020

**Content by:** Kate Konieczka

**Present:** N/A

**Goals:** Develop background knowledge on mandibular fractures in dogs

**Content:**

In dogs the mandible is comprised of two bones joined on the mid line by a symphysis - which is a non movable joint.

- the tooth roots, nerves, blood vessels and salivary ducts are located within and adjacent to the mandible
- fractures in the premolar region are the most common in dogs
- jaw fractures make up 1.5 to 3 percent of all fractures in dogs
- the average healing time is 5.5 and 6.3 weeks
- average complication rate is 34%

Common treatments

- Tape Muzzle
  - applied with canine teeth in perfect occlusion
  - allowance for the mouth to open .5 - 1 cm

Advantages

- does not disrupt blood supply
- does not require teeth to be present

Disadvantages

- is not recommended to be used with unstable fracture because movement will occur at the fracture site
- impaired panting
- aspiration of food
- dermatitis

**Conclusions/action items:**

**Sources**

[1] "Small Animal Topics," ACVS. [Online]. Available: <https://www.acvs.org/small-animal/mandibular-fractures>. [Accessed: 09-Sep-2020]

[2] G. Harasen, "Maxillary and mandibular fractures," Aug-2008. [Online]. Available: <https://www.ncbi.nlm.nih.gov/pmc/articles/PMC2465795/>. [Accessed: 09-Sep-2020]

[3] "World Small Animal Veterinary Association World Congress Proceedings, 2014 - VIN," *Powered By VIN*. [Online]. Available: <https://www.vin.com/apputil/content/defaultadv1.aspx?pid=12886>. [Accessed: 09-Sep-2020]

KATHERINE KONIECZKA - Oct 07, 2020, 12:42 PM CDT

KATHERINE KONIECZKA - Sep 09, 2020, 1:36 PM CDT

**time\_stamp\_2.PNG(1.7 KB) - download** This is the original time stamp, I needed to go back and edit my citations



## Dimensions of a Dog Mandible

KATHERINE KONIECZKA - Oct 07, 2020, 12:32 PM CDT

**Title:** Dimensions of a dog mandible

**Date:** 10/6/2020

**Content by:** Kate Konieczka

**Present:** N/A

**Goals:** Research the dimensions of a dog mandible in order to create an accurate model in solidworks.

**Content:**

Unfortunately, I was unable to find good research articles that would provide average dimensions of the mandible that we could put into solidworks. I have reached out to the Makerspace about 3D scanning the mandible that Dr. Thatcher gave us. We are going to meet sometime on Zoom for a preliminary consultation and then decide the best plan of action from there. In my original email to them they did say we could get dimensions from 3Ds scanning. Once we have those measurements and scans I will upload those in to this section of my lab notebook. For now measurements of the dog skull using a ruler are posted below.

**Conclusions/action items:**

In the future we will hopefully get more accurate measurements for the mandible. For now we will use the measurements obtained by using a ruler that are posted here.

KATHERINE KONIECZKA - Oct 07, 2020, 12:38 PM CDT



[file7.jpeg\(4 MB\) - download](#)

KATHERINE KONIECZKA - Oct 07, 2020, 12:39 PM CDT



file8.jpeg(3.6 MB) - [download](#)

KATHERINE KONIECZKA - Oct 07, 2020, 12:39 PM CDT



file6.jpeg(3.8 MB) - [download](#)

KATHERINE KONIECZKA - Oct 07, 2020, 12:39 PM CDT



file4.jpeg(3.6 MB) - [download](#)

KATHERINE KONIECZKA - Oct 07, 2020, 12:39 PM CDT



file5.jpeg(3.6 MB) - [download](#)

KATHERINE KONIECZKA - Oct 07, 2020, 12:39 PM CDT



file3.jpeg(3.5 MB) - [download](#)

KATHERINE KONIECZKA - Oct 07, 2020, 12:39 PM CDT



file2.jpeg(3.4 MB) - [download](#)

KATHERINE KONIECZKA - Oct 07, 2020, 12:39 PM CDT



file1.jpeg(3.3 MB) - [download](#)

KATHERINE KONIECZKA - Oct 07, 2020, 12:39 PM CDT



file-3.jpeg(3.5 MB) - [download](#)

KATHERINE KONIECZKA - Oct 07, 2020, 12:41 PM CDT



file1-1.jpeg(3.2 MB) - [download](#)



file-4.jpeg(3.3 MB) - [download](#)

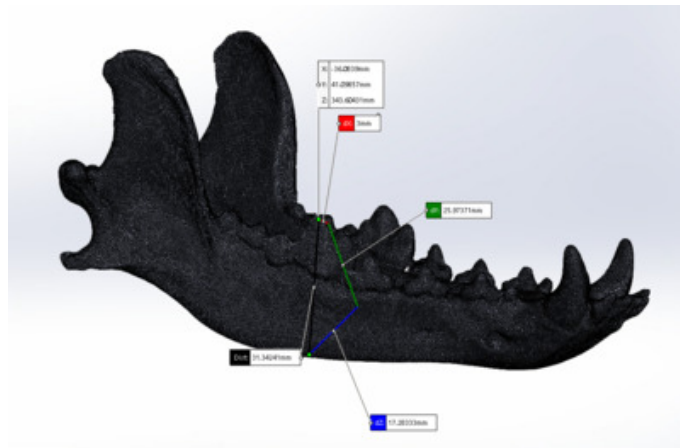

view1.PNG(456.5 KB) - [download](#) Jaw Dimensions



view2.PNG(452.8 KB) - [download](#) Jaw Dimensions

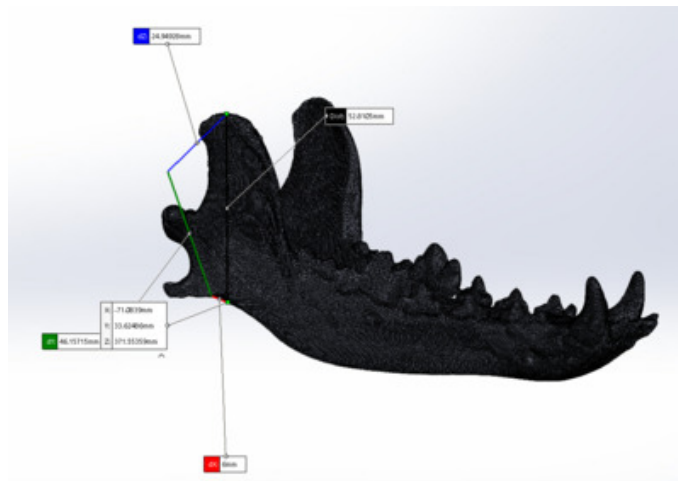

view3.PNG(369.7 KB) - [download](#) Jaw Dimensions

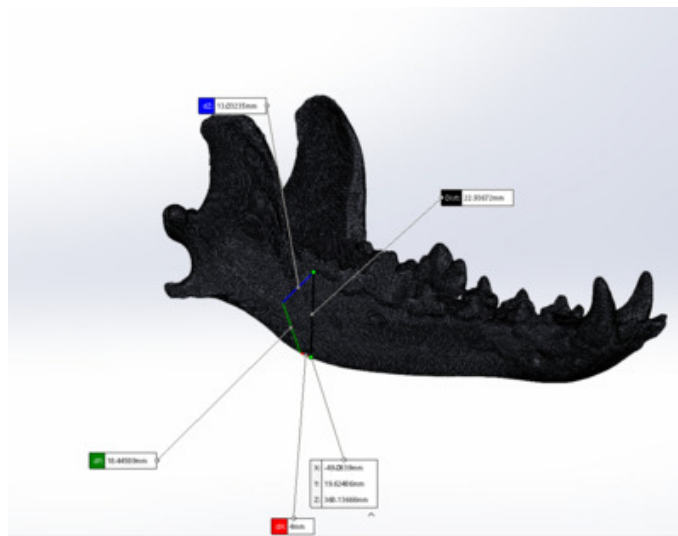

view4.PNG(366.6 KB) - [download](#) Jaw Dimensions

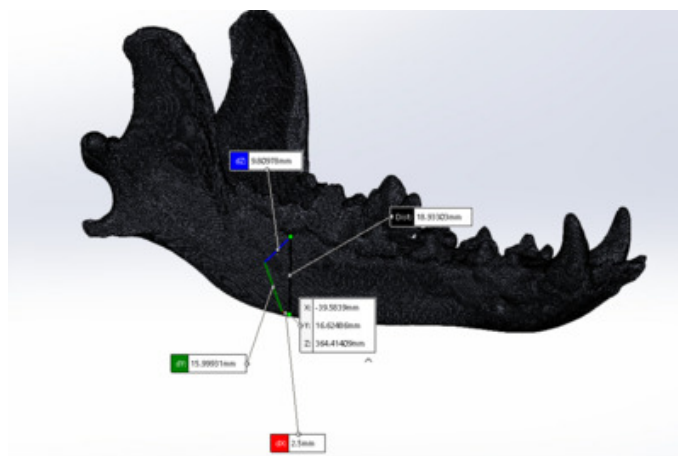

view5.PNG(313 KB) - [download](#) Jaw Dimensions

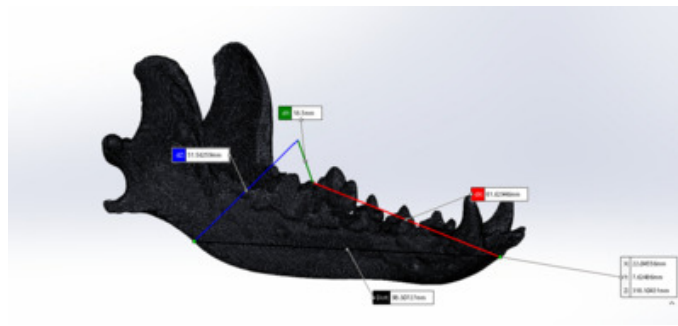

view6.PNG(362.7 KB) - [download](#) Jaw Dimensions

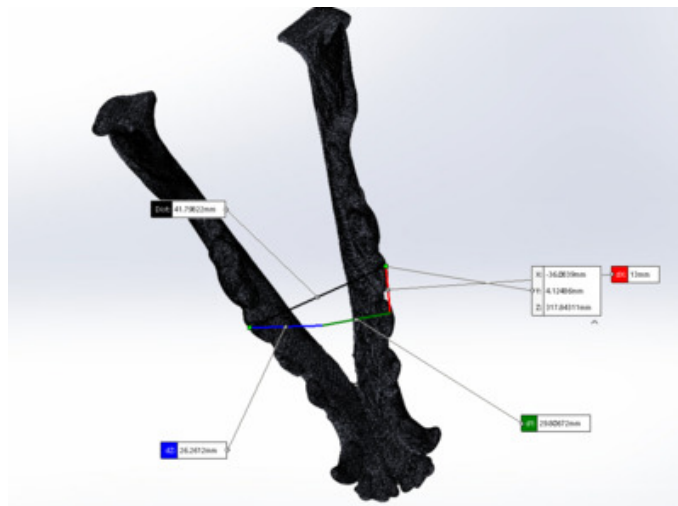

view7.PNG(284.9 KB) - [download](#) Jaw Dimensions

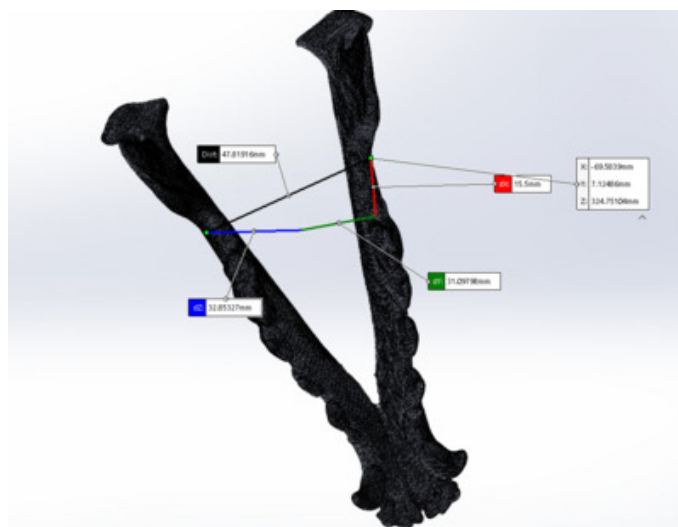

view8.PNG(267.2 KB) - [download](#) Jaw Dimensions

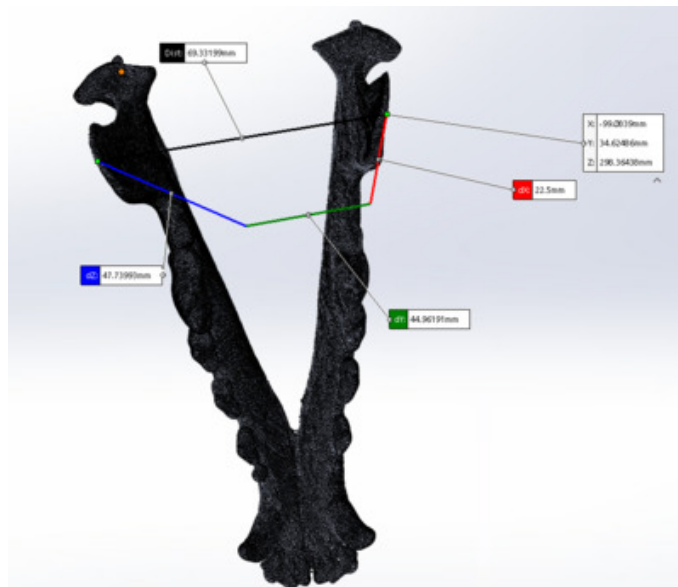

view9.PNG(272.9 KB) - [download](#) Jaw Dimensions

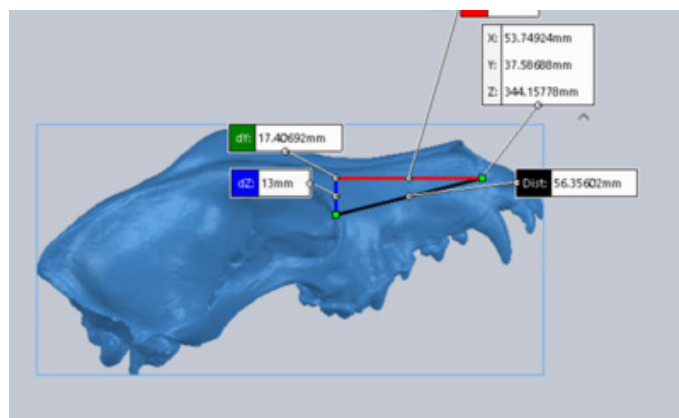

jaw1.PNG(250 KB) - [download](#)

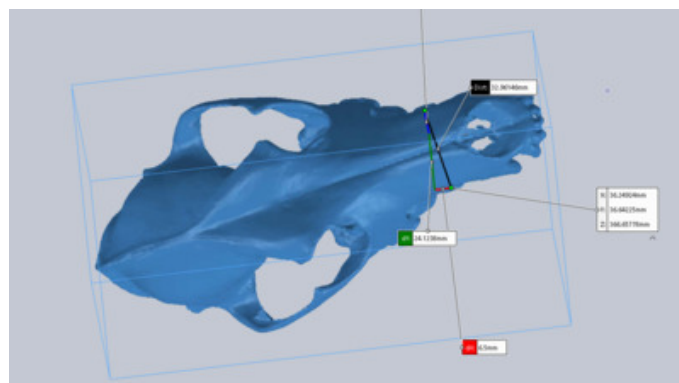

jaw2.PNG(210.5 KB) - [download](#)



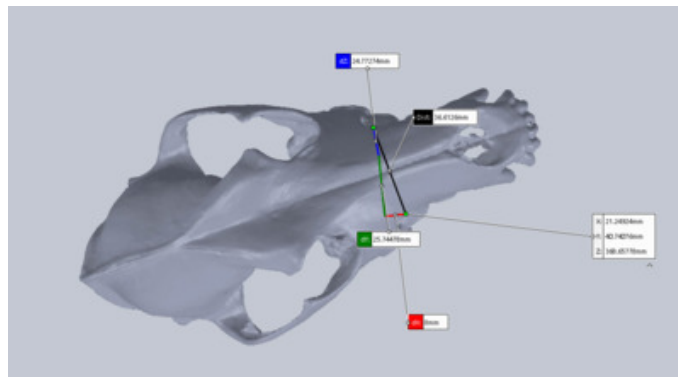

jaw3.PNG(188.8 KB) - [download](#)

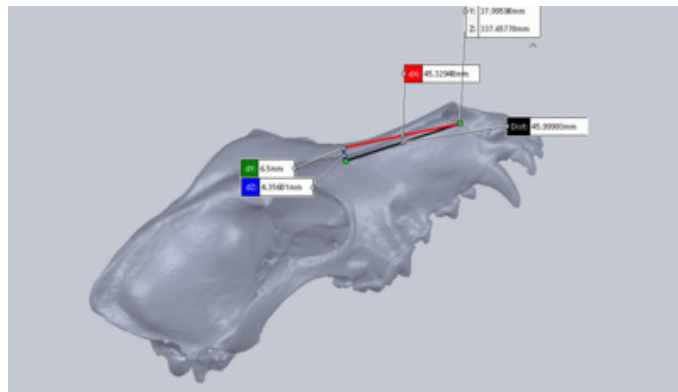

jaw4.PNG(168.8 KB) - [download](#)



## Mechanical properties of bone

---

KATHERINE KONIECZKA - Dec 09, 2020, 10:15 AM CST

**Title:** Mechanical properties of bone

**Date:** 10/16/2020

**Content by:** Kate Konieczka

**Present:** N/A

**Goals:** Determine the mechanical properties of bone that will be added to a new material in SolidWorks

**Content:**

<b>Shear Modulus</b>	3300 N/mm <sup>2</sup>
<b>Elastic Modulus</b>	5650 N/mm <sup>2</sup>
<b>Poisson's Ratio</b>	0.62
<b>Mass Density</b>	2000 kg/m <sup>3</sup>
<b>Tensile Strength</b>	53 N/mm <sup>2</sup>
<b>Compressive Strength</b>	65.2 N/mm <sup>2</sup>
<b>Yield Strength</b>	44.1 N/mm <sup>2</sup>

**Conclusions/action items:**

[1] E. Morgan et al., "Bone Mechanical Properties in Healthy and Diseased States". Annual Review of Biomedical Engineering, 2018. Available: <https://www.ncbi.nlm.nih.gov/pmc/articles/PMC6053074/>



## Competing and Existing Designs

KATHERINE KONIECZKA - Oct 06, 2020, 9:00 AM CDT

**Title:** Competing and existing designs

**Date:** 9/25/2020

**Content by:** Kate Konieczka

**Present:** N/A

**Goals:** Research existing designs on the market and their patents

**Content:**

### Current Nylon Muzzles

- There are hundreds of different muzzles on the market currently. Most of these muzzles aren't designed to be used in a medical setting. They are designed mostly to restrain the canine in a way that prevents them from biting and barking and protect them from eating things they shouldn't. Patents do exist for these commercial nylon muzzles. Most of them are aimed to improve the adjustability and comfort of the muzzle.
- Current canine muzzles range from the rigid to semi rigid body type, flexible body type and adjustable body type. Examples of each type and their patents are listed below.

### Patents

- Semi rigid/rigid
  - Patent Number: US D659,303 S
  - Date of Patent: May 8, 2012

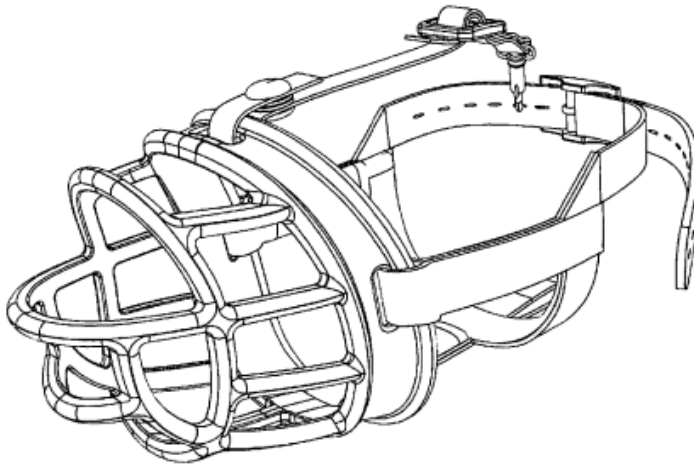

- Flexible body
  - Patent number 5299531
  - Date of patent: April 5, 1994
  - This patents specifically focuses on improving the dogs ability to breathe while also making sure the muzzle stays secure. This is done through the mesh seen on the front.

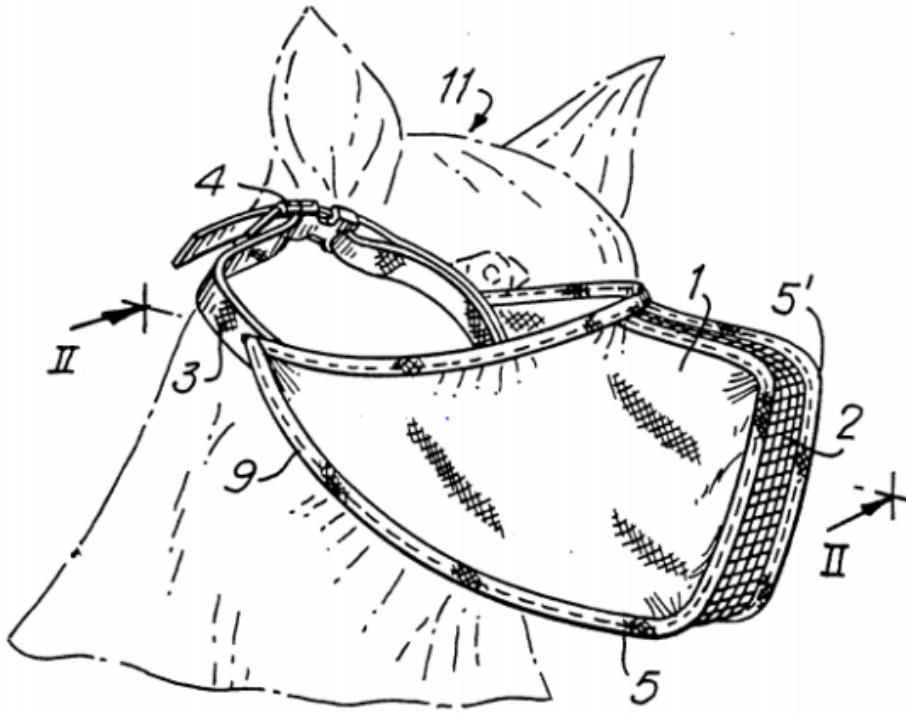

- Adjustability and accessibility
  - Patent still being processed but the application was filled on January 1st 2016
  - application number GB 2550937 A
  - The aim of this muzzle is to provide structure to restrain the dog but also a way for the dog to eat and drink while still wearing the muzzle.

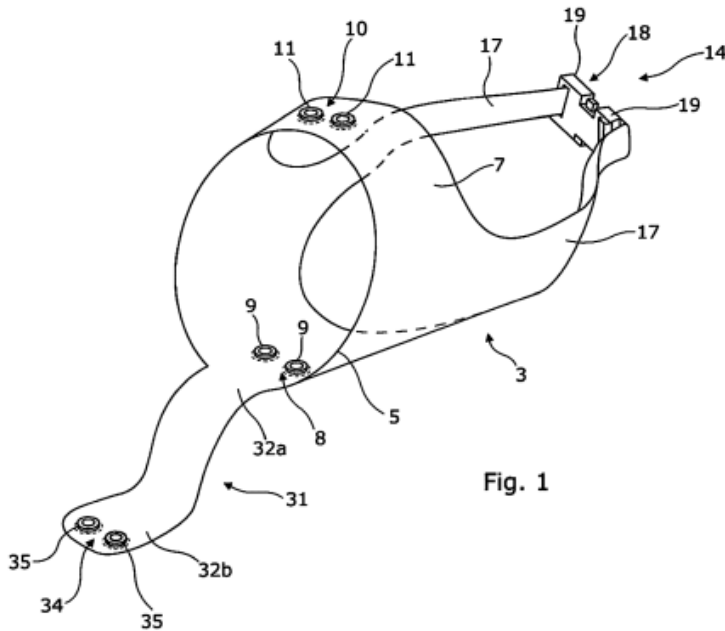

Fig. 1

### Tape muzzles

Currently tape muzzles are the leading treatment for non invasive fracture repair in dog mandibles.

- Common standards of tape muzzles
  - 1 inch tape for smaller dogs and 2 inch tape for larger dogs

- should limit the dogs ability to open its mouth, but allow for the tongue to fit through the incisor teeth.
- The sides of the tape should be fitted to just allow for the veterinarians finger to fit between the tape and the patients skin.
- Complications with the tape muzzle
  - aspiration of food due
  - impaired painting
  - dermatitis
  - Tape muzzles also create a pivot point near the fracture that can actually cause further displacement of the fracture

**Conclusions/action items:**

Now the team has a better understanding of the purpose and use for commercial dog muzzles currently on the market. Most are for restraining the dog not for stability, structure and medical purposes which is the main purpose of the muzzle we are designing.

**References:**

- [1] Mark M. Smith, Loïc F.J. Legendre, "Chapter 29 - Maxillofacial fracture repair using noninvasive techniques" *Oral and Maxillofacial Surgery in Dogs and Cats*, pp. 275-284, 2012.
- [2] R. Mugford, "Muzzle," United States Patent US D659,303 S, May. 8, 2012.
- [3] D. Dietz, "Muzzle" United States Patent 5299531, April. 5, 1994.
- [4] <https://patentimages.storage.googleapis.com/ff/48/8e/f7c31a4586c464/GB2550937A.pdf>

---

KATHERINE KONIECZKA - Oct 06, 2020, 8:55 AM CDT

KATHERINE KONIECZKA - Sep 25, 2020, 12:24 PM CDT

tiem\_stamp.PNG(1.7 KB) - [download](#) Needed to edit the references this is the original time stamp



## Standards and Specifications

---

KATHERINE KONIECZKA - Oct 06, 2020, 7:37 AM CDT

**Title:** Standards and specifications regarding veterinary medical devices

**Date:** 10/6/2020

**Content by:** Kate Konieczka

**Present:** N/a

**Goals:** Research the standards regarding veterinary medical devices

**Content:**

A medical device consists of the following properties

- They help diagnose, cure, and treat an injury, disease or condition
- No chemical reactions are involved
- changes or interacts with the structure and function of the body
- Metabolism does not take place in order for the function of the medical device to be achieved

Medical devices pertaining to humans must undergo an extensive approval process by the FDA. The devices can be categorized into class I, class II, and class III.

In comparison to the approval process of human medical devices there is no formal approval process for veterinary medical devices.

- Veterinary medical devices are subjected to the provisions of the FFCDA, which is the Federal Food Drug and Cosmetic Act.
  - The FFCDA oversees misbranding, mislabeling and adulteration. These are all areas that have to do with how the product is marketed

Key differences between human and veterinary medical devices

- Companies or manufactures that exclusively operate within veterinary medicine are not required to register their establishments or list their devices with the FDA
- There is no premarket approval requirements
- There are no premarket notification requirements
- There are no registered or approved veterinary medical devices

**Conclusions/action items:**

Overall this information will be very useful if our team ever wants to take our product to the market. There are a clear distinction between human and veterinary medical devices.

References

[1] Biological and Therapeutic Agents Committee, "Medical Devices," AAEP, Lexington, KY, USA, Rep. no. 1, 2020. Accessed: 16 September 2020. [Online] Available: <<https://rmtcnet.com/wp-content/uploads/2015/07/AAEPMedicalDevicesInEquineMedicine.pdf>>



## 2020/09/09 Mechanics - cantilever

---

KATHERINE KONIECZKA - Dec 09, 2020, 9:16 AM CST

**Title:** Cantilever Mechanics

**Date:** 9/9/2020

**Content by:** Kate Konieczka

**Present:** N/A

**Goals:** Research the mechanics of cantilever structures for the oral region

**Content:**

in orthodontics, a cantilever is any piece of wire which is attached to a removable appliance and the end is tied to another unit

- a force is developed with respect to the point of the force application of the other end. The overall magnitude of the two forces is equal and opposite

- Moment =  $F \times d$  ( force times distance (length of device)

- easily estimate the force applied

- an important characteristic of the force that is generated by the cantilever is the high level of constancy over time as well as deactivation. I.E the forces at the two ends maintain their direction and decrease in a linear manner

- for an intentional force and less moment the cantilever should be short and the cross section dimension should be reduced

**Conclusions/action items:**

Using this information, we can begin our preliminary designs and determine the best way to design the device to distribute the forces throughout the jaw.

[1] Tekadmin, "Procedures - Cantilever Mechanics," *panorthodontics*. [Online]. Available: <https://www.panorthodontics.com/procedures-cantilever-mechanics/>. [Accessed: 07-Oct-2020]

[2] X. Fang and P. G. Charalambides, "The fracture mechanics of cantilever beams with an embedded sharp crack under end force loading," *Engineering Fracture Mechanics*, 30-Sep-2015. [Online]. Available: <https://www.sciencedirect.com/science/article/pii/S001379441500555X>. [Accessed: 09-Nov-2020].

---

KATHERINE KONIECZKA - Oct 07, 2020, 12:20 PM CDT

KATHERINE KONIECZKA - Sep 09, 2020, 1:55 PM CDT

ts.PNG(1.8 KB) - [download](#) Original time stamp, I needed to go back and edit the sources



# Preliminary Design

KATHERINE KONIECZKA - Sep 25, 2020, 12:12 PM CDT

**Title:** Preliminary Design**Date:** 9/22/2020**Content by:** Kate Konieczka**Present:** N/A**Goals:** Come up with a preliminary design**Content:**

The goal of my design was to make it as adjustable as possible while maintaining the structural integrity. It includes battens for structural support and Velcro on with side to maximize the size of fit.

KATHERINE KONIECZKA - Sep 25, 2020, 8:46 AM CDT

idea: make it as adjustable as possible while maintaining structural integrity.



underneath  
lower mandible

dr. MATHER sent in his idea so I will go off of that-



[Preliminary\\_drawing\\_.pdf\(743.2 KB\) - download](#)





---

KATHERINE KONIECZKA - Dec 09, 2020, 7:48 AM CST

**Title:** Materials Research

**Date:** 10/14/2020

**Content by:** Kate Konieczka

**Present:** N/A

**Goals:** Research and detail possible materials that we can use to construct the muzzle and their prices.

**Content:**

Structural material for battens

Polypropylene

- Thermoplastic
- Chemcially resistant
- Is a tough material. It will deform plastically and elastcially
- It has a high fatigue resistance, meaning it will keep its shape even after being bent and deformed.
- This material is also cheap and can be easily 3D printed using the printers avaiable in the Makers Space

**Conclusions/action items:**

Polypropylene is a good choice for battens in the muzzle. We need a material that wont deform after being bent once or twice, a product that is strong enough to withstand the bite forces of a dog and something that can be easily purchased or fabricated using a 3D printer

C. M. Staff, "Everything You Need To Know About Polypropylene (PP) Plastic." [Online]. Available: <https://www.creativemechanisms.com/blog/all-about-polypropylene-pp-plastic>. [Accessed: 14-Oct-2020].



# FEA simulation attempt 1

KATHERINE KONIECZKA - Dec 09, 2020, 12:04 PM CST

**Title:** FEA Simulation Attempt 1

**Date:** 10/16/2020

**Content by:** Kate Konieczka

**Present:** N/A

**Goals:** Use the 3D scans of the skulls to obtain accurate measurements for our model and perform FEA on the scans

**Content:**

The first thing I did with the 3D scans was import them into solidworks and obtain accurate measurements from them. Pictures of those measurements are attached below.

Once the scan was meshed and could be opened in SolidWorks as a solid body FEA attempts were made. Due to the complex geometry and the holes in the scan the simulation failed each time. Although we were able to add fixtures and forces exactly where we wanted with these scans. Attached is a screenshot of the model in SolidWorks with the fixtures and forces applied.

**Conclusions/action items:**

Create a simplified model to test in SolidWorks

KATHERINE KONIECZKA - Dec 09, 2020, 7:08 AM CST

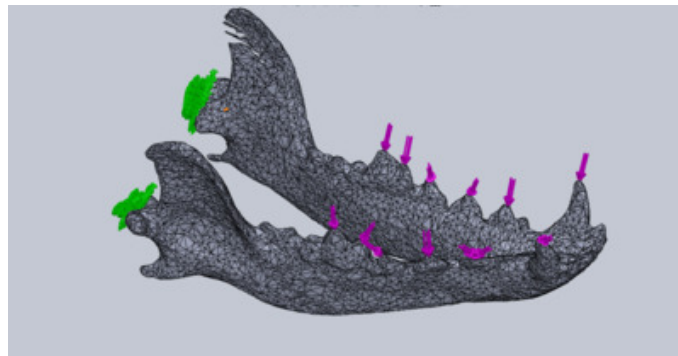

[showandtell.PNG\(397.2 KB\) - download](#) Screenshot of the 3D scanned model in SolidWorks with forces and fixtures applied to it

KATHERINE KONIECZKA - Dec 09, 2020, 9:41 AM CST

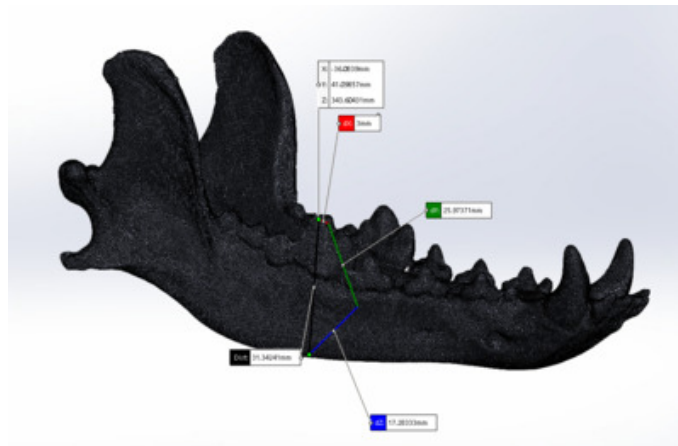

[view1.PNG\(456.5 KB\) - download](#) Screenshots of measurements of the scanned skull



view2.PNG(452.8 KB) - [download](#) Screenshots of measurments of the scanned skull

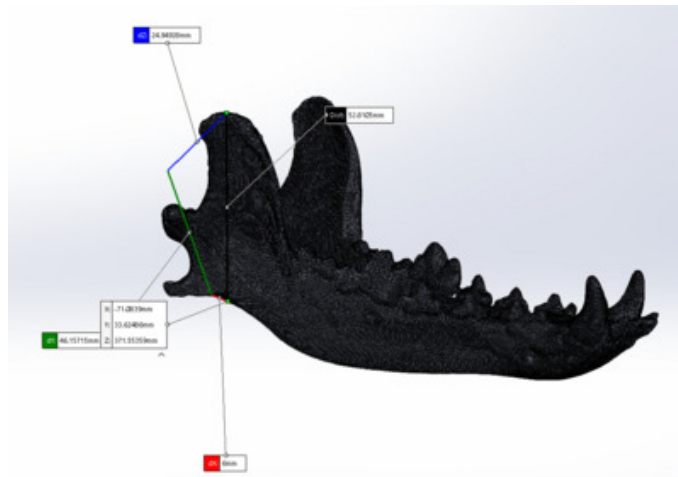

view3.PNG(369.7 KB) - [download](#) Screenshots of measurments of the scanned skull

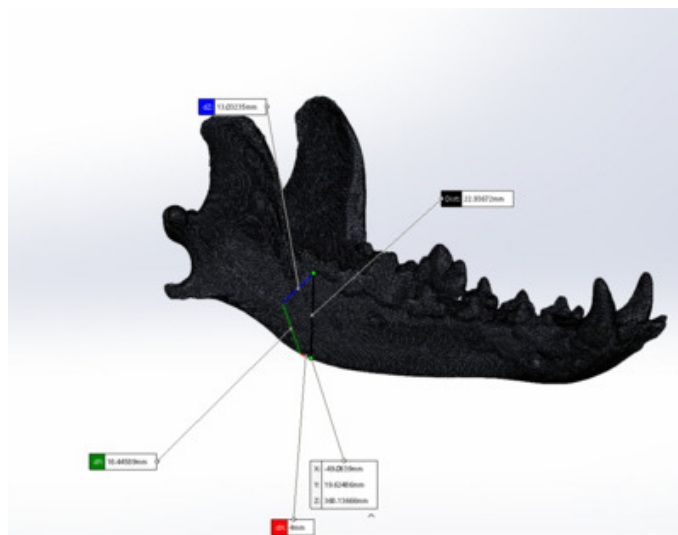

view4.PNG(366.6 KB) - [download](#) Screenshots of measurments of the scanned skull

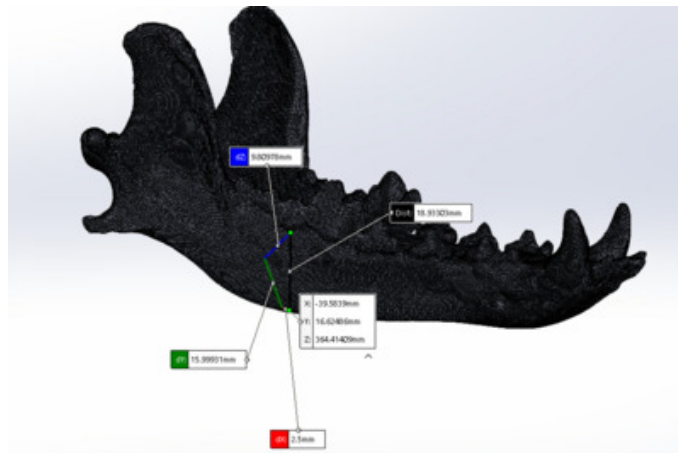

view5.PNG(313 KB) - [download](#) Screenshots of measurments of the scanned skull

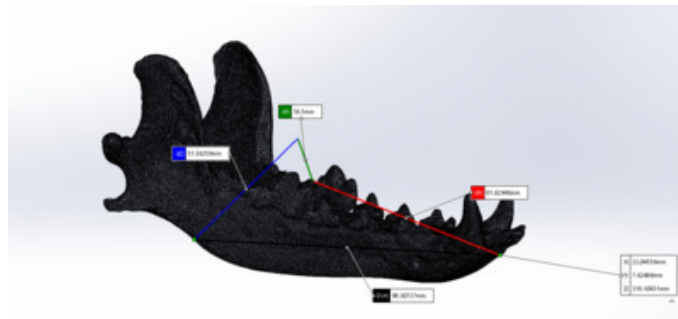

view6.PNG(362.7 KB) - [download](#) Screenshots of measurments of the scanned skull

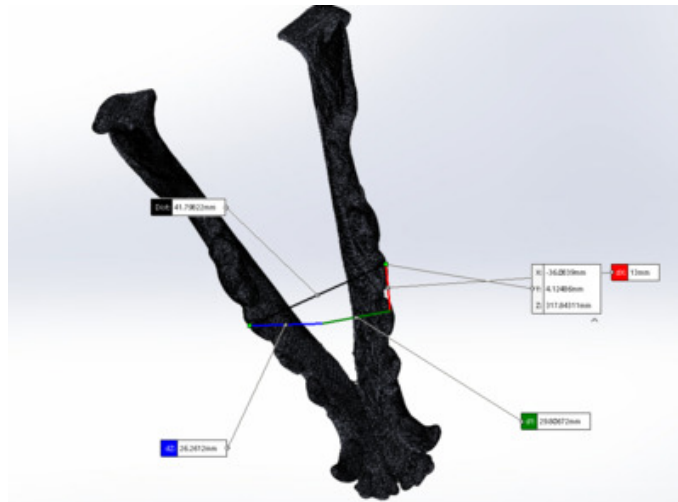

view7.PNG(284.9 KB) - [download](#) Screenshots of measurments of the scanned skull

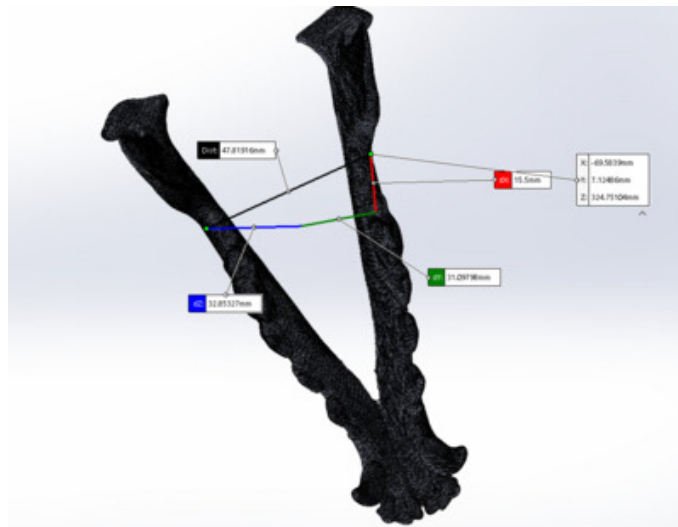

view8.PNG(267.2 KB) - [download](#) Screenshots of measurements of the scanned skull

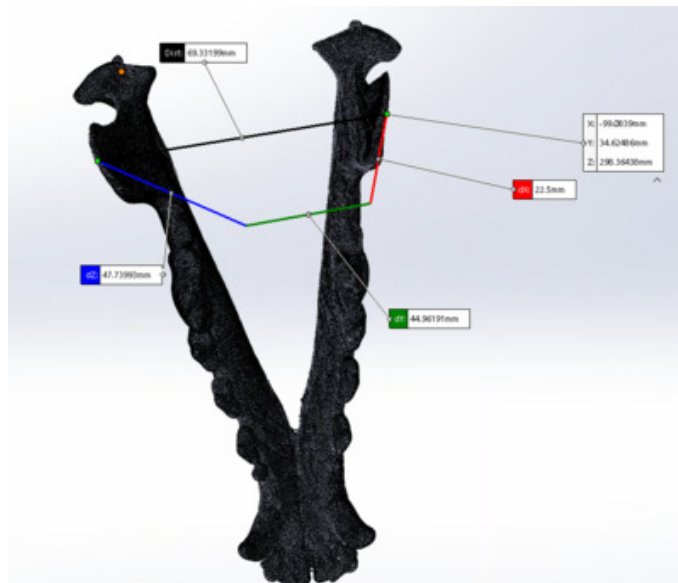

view9.PNG(272.9 KB) - [download](#) Screenshots of measurements of the scanned skull



## FEA simulation attempt 2

KATHERINE KONIECZKA - Nov 29, 2020, 9:12 PM CST

**Title:** FEA simulation attempt 2

**Date:** 10/28/2020

**Content by:** Kate Konieczka

**Present:** N/A

**Goals:** Develop a realistic model of the mandible and perform FEA analysis

**Content:**

In this attempt I used the recently imported STL file of the mandible to sketch the mandible accurately. My hope was to build a model either around or off of the 3D scanned model.

Attempt 1: outlining the mandible (image attached below)

- This one did not work. I was not able to extrude the part, but I learned how to best use the spline tool for my second attempt.

Attempt 2: building a model around the 3D scan of the mandible (image attached below)

- The first problem with this model was that I was unable to apply fixtures and forces where I wanted. To fix this I created a plane perpendicular to the region where I wanted the fixture or force. By doing this I was able to add a part to the original sketch I made in which fixtures could be applied to.

- From there I went on to the FEA simulation. I was able to add fixtures however when I went to mesh the part it needed a thickness defined for the 3D sketched part. This was because I had created the sketch around the model so when I went to do the simulation the 3D sketch would also be apart of the simulation. Every time I would try to define a thickness solid works would crash.

**Conclusions/action items:**

KATHERINE KONIECZKA - Nov 29, 2020, 9:24 PM CST

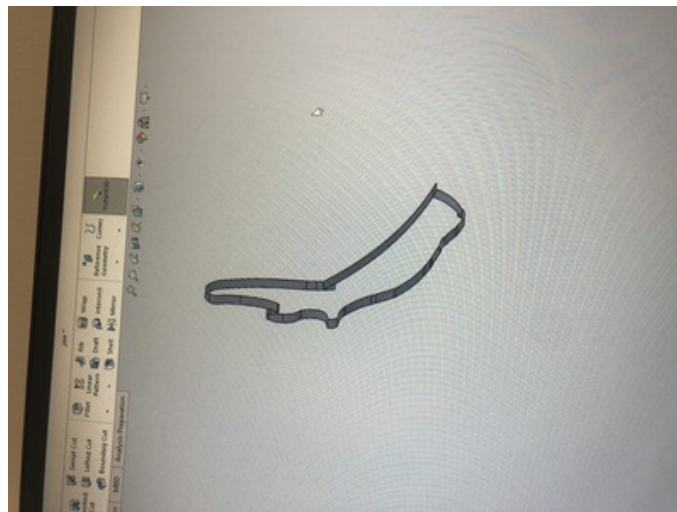

file2-4.jpeg(5.9 MB) - [download](#) Initial sketch of mandible (attempt 1)

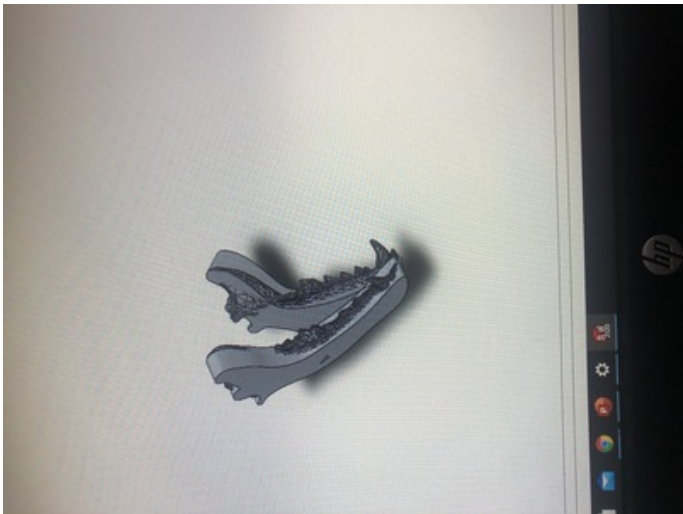

file3-4.jpeg(5.4 MB) - [download](#) Sketch around the 3D scan (attempt 2)



## FEA simulation attempt 3

KATHERINE KONIECZKA - Dec 09, 2020, 6:47 AM CST

**Title:** FEA simulation attempt 3

**Date:** 11/29/2020

**Content by:** Kate Konieczka

**Present:** N/A

**Goals:** Develop a simplified model of the jaw to run FEA simulations on

**Content:**

1. Use the Spline tool to create a rough sketch of the mandible.

The first sketch I created did not have enough segment. This made it difficult to place the forces and fixtures where I wanted.

In my second attempt I used the spline tool and creates lots of segments to in order to accurately places the fixtures and forces. We are going to need fixture at the point where the joint rotates and forces long the the top to simulates the bites forces and sections on the bottom of the mandible to represent the reaction forces from the muzzle and and the tape muzzle. Pictured of this attempt are labeled an attached below. The are labeled as attempt 2.

This part was accidentally deleted, however there are several improvements to be made when I remake the part.

- Decrease the distance between the point of fracture
- Increase the number of segments to have more accurate placements of the fixtures and force

My final sketch is picture below. The segements were accurately spaced to allow for the forces to be best placed. FEA analysis was then conducted on this model.

**Conclusions/action items:**

For my next attempt I will need to determine a more accurate way to model the fracture and include more segments in the original part.

KATHERINE KONIECZKA - Nov 29, 2020, 8:36 PM CST

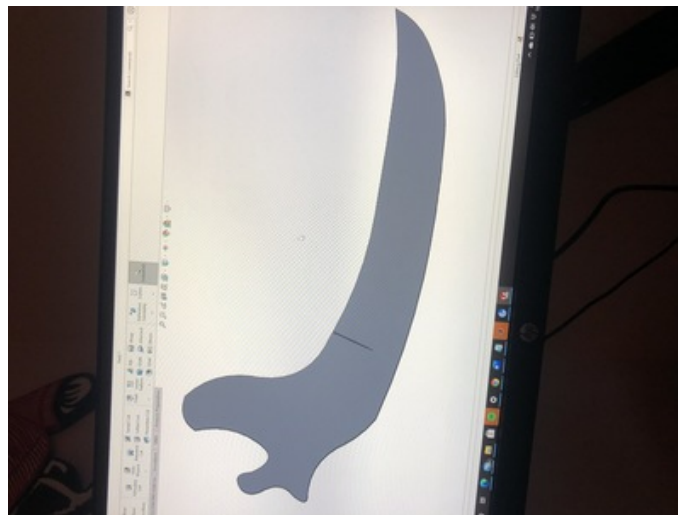

file3-3.jpeg(2.6 MB) - [download](#) Image of the overall model of the mandible including the fracture



KATHERINE KONIECZKA - Nov 29, 2020, 8:35 PM CST

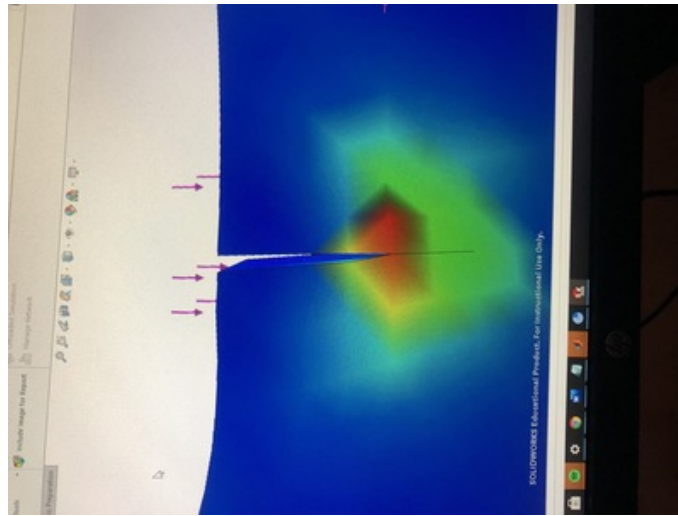

file1-4.jpeg(3.1 MB) - [download](#) Muzzle support - forces at fracture site (attempt 2)

KATHERINE KONIECZKA - Nov 29, 2020, 8:35 PM CST

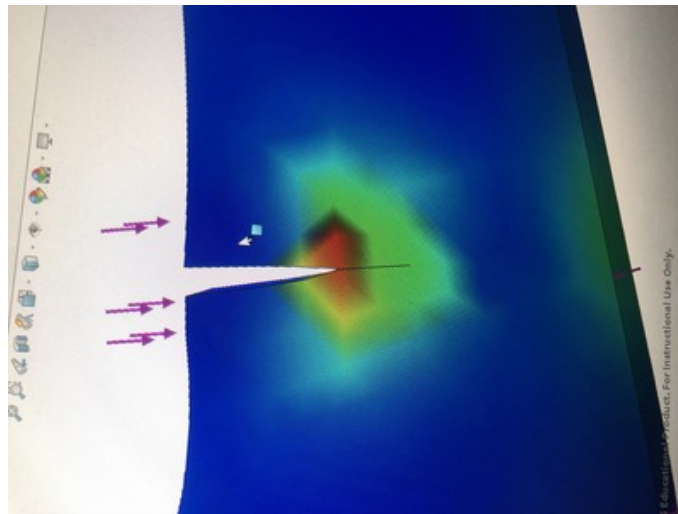

file2-3.jpeg(3.8 MB) - [download](#) tape muzzle support - forces at fracture site (attempt 2)

KATHERINE KONIECZKA - Nov 29, 2020, 8:35 PM CST

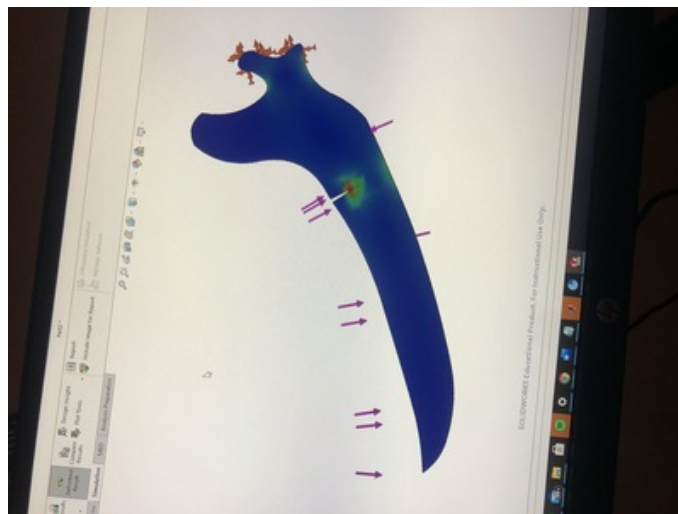

file-9.jpeg(4.5 MB) - [download](#) tape muzzle support - forces at fracture site (attempt 2)

KATHERINE KONIECZKA - Dec 09, 2020, 6:48 AM CST

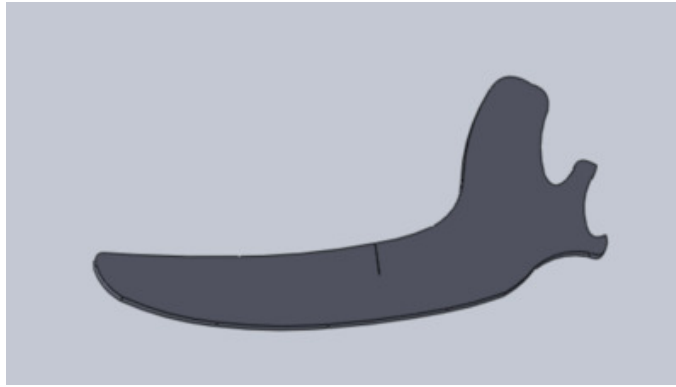

final\_sketch\_mandible.PNG(37.6 KB) - [download](#) Final model of mandible used for FEA

KATHERINE KONIECZKA - Dec 09, 2020, 6:54 AM CST

**Title: FEA testing on attempt 3****Date:** 11/29/2020**Content by:** Kate Konieczka**Present:** N/A**Goals:** Perform the simulations**Content:**

A detailed protocol can be seen in the project information --> testing and results --> protocols folder.

Attached below are images of each simulation and an image of how we used the probe tool to collect our data.

**Conclusions/action items:**

Develop a more accurate model to perform simulations on.

KATHERINE KONIECZKA - Dec 09, 2020, 10:21 AM CST

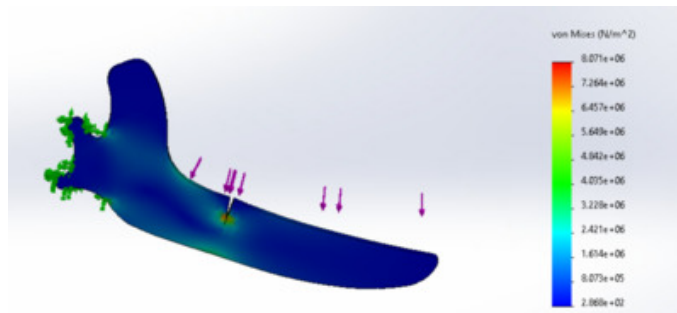

feano\_support\_2\_.PNG(223.6 KB) - [download](#) FEA for simulation with no support

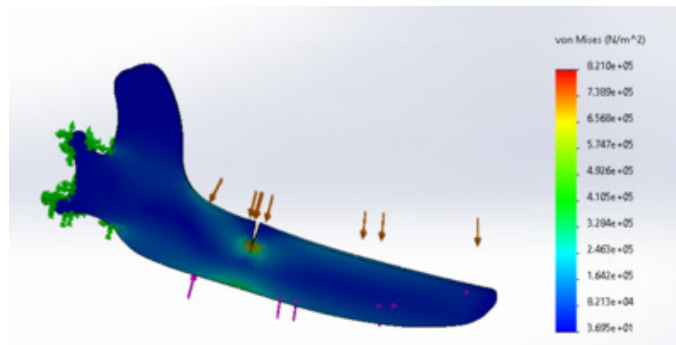

supportfea\_2\_.PNG(190.7 KB) - download FEA for simulation with full support

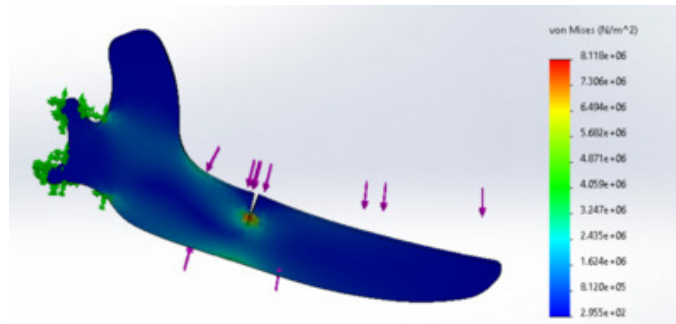

tapefea\_2\_.PNG(218.1 KB) - download FEA for simulation with tape support

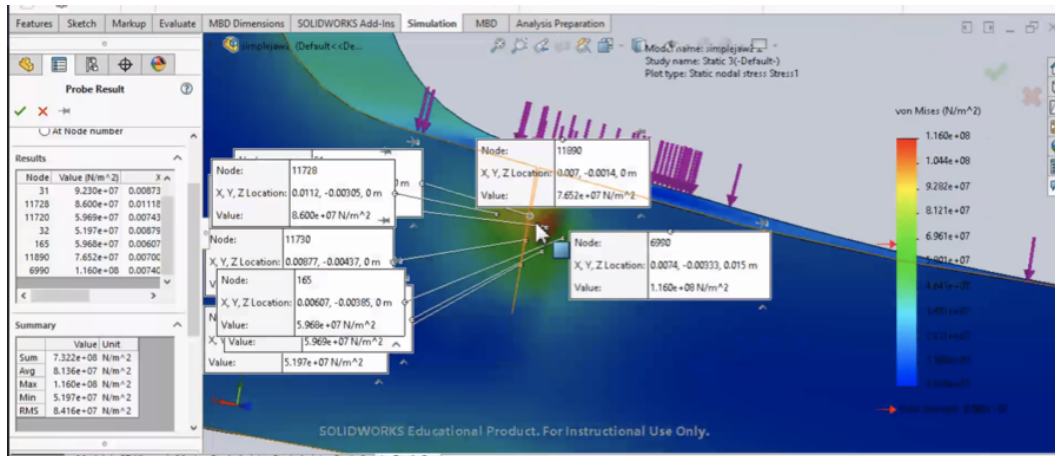

Screenshot of how the probe tool was used to collect data on the stress values



## 9/10/20 - Mandibular Treatments

ALEXANDRIA THAO - Sep 11, 2020, 12:11 AM CDT

**Title:** Background research into mandibular fractures and treatments

**Date:** 9/10/2020

**Content by:** Alexandria Thao

**Present:** Alexandria Thao

**Goals:** To find out how mandibular fractures affect dogs and common treatments and rehabilitation devices

**Content:**

- Tape muzzles are a common and inexpensive form of supporting mandibular fractures (see Fig 1)
- Tape muzzles are non-invasive (along with nylon muzzles), so tooth roots, neurovascular structures, and the vascular supply to fracture fragments are not affected
- Many maxillomandibular fixation supports such as muzzles run the risk of aspiration, difficulty in eating and breathing, and thermoregulation
- Much of the mandible occupied by tooth roots and neurovascular structures leads to stabilization primarily with muzzles or wire. (see Fig. 2) Since muzzles are a major treatment, need improvement.
- Tape muzzles do not provide rigid support, could add in boning to nylon muzzles for added support?

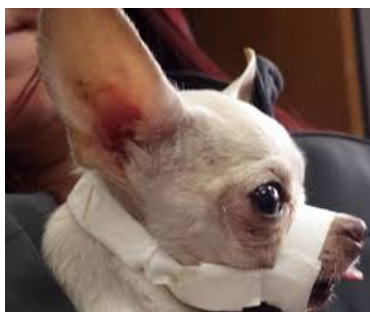

*Figure 1. Tape muzzle example. Courtesy of AZ Humane Society.*

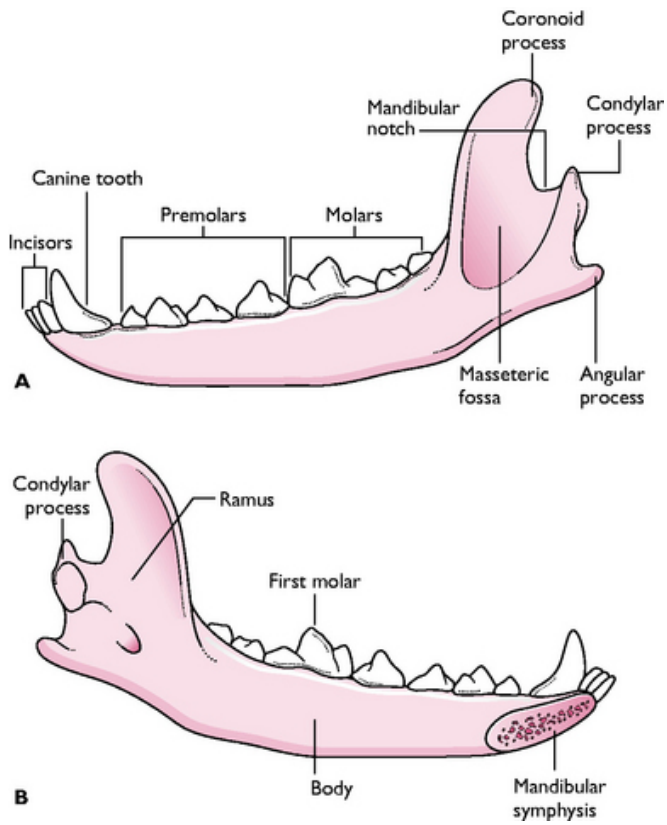

Figure 2. Mandibular anatomy of dogs.

#### References:

- [1] Umphlet, R. C., & Johnson, A. L. (1990). Mandibular Fractures in the Dog A Retrospective Study of 157 Cases. *Veterinary Surgery*, 19(4), 272–275. <https://doi.org/10.1111/j.1532-950X.1990.tb01184.x>
- [2] Tape Muzzle Helps Maxillofacial Injuries—Veterinary Medicine at Illinois. (2015, September 22). *University of Illinois College of Veterinary Medicine*. <https://vetmed.illinois.edu/tape-muzzle-helps-maxillofacial-injuries/>
- [3] <https://www.azhumane.org/wp-content/uploads/2019/03/Jaw-Fracture.pdf>
- [4] Glyde M, Lidbetter D Management of fractures of the mandible in small animals *In Practice* 2003;25:570-585.

#### Conclusions/action items:

We can look at current commercially available nylon muzzle design and seek to improve the stability and fit going off of the tape muzzle drawbacks. I can also look into how we will actually measure and test our design in a remote setting.



## 9/16/20 - Canine forces in the mandible

---

ALEXANDRIA THAO - Oct 05, 2020, 3:58 PM CDT

**Title:** Research in to mandibular forces in canines

**Date:** 9/16/2020

**Content by:** Alexandria Thao

**Present:** Alexandria Thao

**Goals:** To find out the forces within a dogs mouth in order to replicate stresses in our 3D modelling

**Content:**

- Canine forces in the mouth are generated by the masticatory muscles, mandibles, maxillae, temporomandibular joints, and the teeth
  - Jaw adductor muscles (temporal, masseter, and medial and lateral pterygoid muscles) are responsible for closing the mouth, jaw movement, and controlling bite force (see Figure 1)
- Body weight and skull size are major factors in the amount of force behind a dogs bite
  - Dog skulls range in many sizes, for example a pug vs blood hound
  - Minor influences also include oral pain, thus a dog with a mandibular fracture may not be able to exert a large amount of force
- The premolar and molar teeth have a scissoring action resulting in the mandibles mainly moving in a hinge-like vertical motion - there is little lateral motion available
- transducer test - ranged from 13-1395 N, with mean of 256 N
- prosthetic implant transducer - 150 N for bone and 70 N for dry food, dependent on location of transplant
- electrical stimulation of jaw adductor muscles - 550 +/-35 N at first stimulation
- in vitro measurements - 220-560 N for canine teeth and 310-1100 N for carnassial teeth

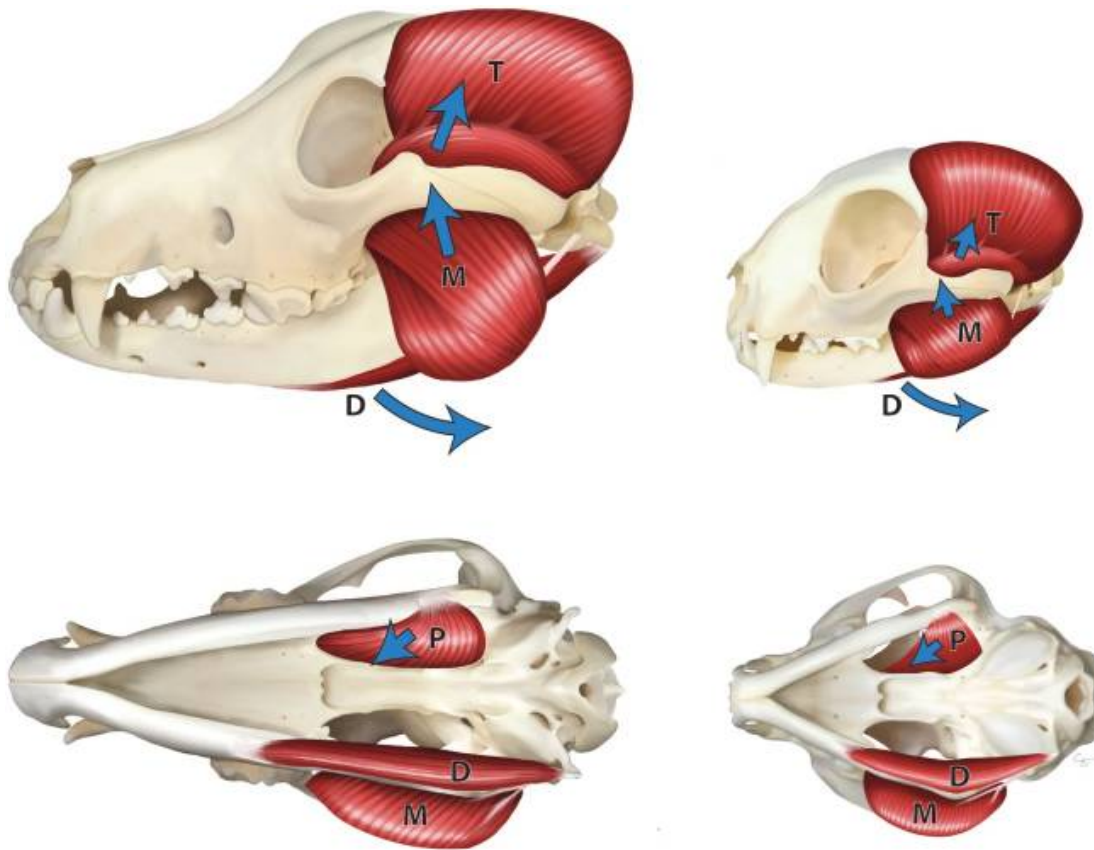

Figure 1. Masticatory muscles in a dog (left) and cat (right). M is the masseter muscle; T is the temporal muscle; P is the pterygoid muscle; and D is the digastric muscles

#### References:

- [1] S. E. Kim, B. Arzi, T. C. Garcia, and F. J. M. Verstraete, "Bite Forces and Their Measurement in Dogs and Cats," *Front Vet Sci*, vol. 5, Apr. 2018, doi: [10.3389/fvets.2018.00076](https://doi.org/10.3389/fvets.2018.00076).

#### Conclusions/action items:

Dog bite forces are difficult to measure and depend on a variety of factor such as skull size and shape, body weight, and oral pain. The force (in N) also ranges widely depending on how it was measured. More research into bite forces and mandibular structure is needed to find a more precise amount of force in order to model a dog's mandible.



## 10/6/20 - Polyamide (Nylon)

ALEXANDRIA THAO - Dec 09, 2020, 11:35 AM CST

**Title:** Background of Nylon Material Properties

**Date:** 10/6/20

**Content by:** Alexandria Thao

**Present:** Alexandria Thao

**Goals:** To find out why most commercial dog muzzles are made of nylon and find out nylon's material properties to help in 3D modeling.

**Content:**

- synthetic polymers --> can be melted into fibers and films
- strong and elastic fibers --> stronger than polyester
- tough and resistant to abrasions --> can stand up to dog rubbing against stuff
- easy to wash (good for owner and hygiene of dog)
- good thermal and chemical resistance
- not very moisture-wicking --> may be an issue with ventilation/breathability
- Major manufacturers to look into:
  - Nylstar
  - Invista
  - Asahi-Kasei
  - BASF
  - Radici Group
  - Universal Fibers
- Physical Properties:
  - Tensile Strength: 90-185 N/mm<sup>2</sup> (1 MPa = 1 M/mm<sup>2</sup>)
    - 62-122 MPa according to another source
    - 85 MPa
  - Notched Impact Strength: 5-13 kJ/m<sup>2</sup>
  - Thermal Coefficient of Expansion: 20-90 \*10<sup>-6</sup>
  - Max Continual Use Temperature: 150-185°C (302-365°F)
  - Density: 1.13-1.41 g/cm<sup>3</sup>

### NYLON FIBER PROPERTIES

Tensile Strength (Tenacity)	Excellent
Abrasion Resistance	Excellent
Absorbency	Fair
Static Resistance	Fair - Poor
Heat Resistance	Fair
Wrinkle Resistance	Good - Excellent
Resistance to Sunlight	Poor
Elasticity	Excellent
Flame Resistance	Does Not Burn
Resilience	Excellent



[1]

- Purchasing:
  - available to be 3D printed using MakerSpace Ultimakers
  - can buy individual sheets and cut them down to size
    - from freckleface.com (courtesy of TeamLab recommendations)
  - fabric can be bought from Joann's or other fabric supply store if in stock (?)

**References:**

[1] "Polymer Properties Database." *Nylon Fibers*, Polymer Properties Database, [polymerdatabase.com/Fibers/Nylon.html](http://polymerdatabase.com/Fibers/Nylon.html).

[2] "Nylons (Polyamide)." <https://www.bpf.co.uk/plastipedia/polymers/polyamides.aspx> (accessed Oct. 06, 2020).

[3] "PA Polyamide Nylon - TECAMID | Ensinger." <https://www.ensingerplastics.com/en-us/shapes/engineering-plastics/pa-polyamide> (accessed Oct. 16, 2020).

**Conclusions/action items:**

Since nylon is relatively tough and elastic, it will hold up to the bite forces of a dog better than compared to other materials. I will continue to research on material properties in order to figure out how to input the restraints in SolidWorks. I will also share my research with the team to finalize our materials design matrix.



## 10/15/20 - Polyester

---

ALEXANDRIA THAO - Oct 15, 2020, 12:32 PM CDT

**Title:** Polyester Material Properties

**Date:** 10/15/20

**Content by:** Alexandria Thao

**Present:** Alexandria Thao

**Goals:** To learn about the material properties of polyester and compare them to other possible muzzle materials.

**Content:**

- aromatic - improve hardness, rigidity, and heat resistance
- aliphatic acids and diols - increase flexibility, lower melting/softening point, and improve process ability
- polyethylene terephthalate (PET)
  - semi-aromatic --> amorphous if rapidly cooled and solidified
  - semi-crystalline if cooled slowly
  - can be processed into fibers
  - high strength and toughness, abrasion and heat resistant
- PET fibers
  - crease and wear resistant
  - low moisture absorption --> could be an issue in breathability
- Polytrimethylene terephthalate (PTT) used in textiles
  - good durability and stain resistance

**References:**

[1] "Properties of Polyesters." <https://polymerdatabase.com/polymer%20classes/Polyester%20type.html> (accessed Oct. 15, 2020).

**Conclusions/action items:**

Use this information to rate our Materials Design Matrix and in 3D modeling the material constraints in SolidWorks.



## 10/15/20 - Cotton

---

ALEXANDRIA THAO - Dec 08, 2020, 9:29 PM CST

**Title:** Cotton Material Properties

**Date:** 10/15/20

**Content by:** Alexandria Thao

**Present:** Alexandria Thao

**Goals:** To find the material properties of cotton in order to compare it with other possible materials for our prototype.

**Content:**

- Good at absorbing water and releasing it --> better breathability rating
- easy to clean and can handle high water temps --> can sterilize muzzle with boiling water to prevent buildup of bacteria
  - good for dog owner
- wrinkle and shrinkage prone --> can reduce effect by blending with other materials (maybe a blend with nylon or polyester?)
- durable and strong
- resists abrasion and pilling
- may weaken from extended exposure to sun
  - might be relevant for dogs with a lot of outdoor exposure (high energy, active dogs)
- density - 1.5-1.54 g/cm<sup>3</sup>

**References:**

[1] Ž. Zupin and K. Dimitrovski, "Mechanical Properties of Fabrics from Cotton and Biodegradable Yarns Bamboo, SPF, PLA in Weft," *Woven Fabric Engineering*, p. 24.

[2] [http://www.sewing.org/files/guidelines/4\\_105\\_cotton.pdf](http://www.sewing.org/files/guidelines/4_105_cotton.pdf)

**Conclusions/action items:**

Cotton may be a viable option instead of nylon for our project. We could use a heavyweight cotton fabric such as canvas instead. I will share my research with the rest of the team to finalize our materials design matrix.



## 10/16/20 - Polypropylene

---

ALEXANDRIA THAO - Dec 09, 2020, 11:32 AM CST

**Title:** Polypropylene Properties

**Date:** 10/16/20

**Content by:** Alexandria Thao

**Present:** Alexandria Thao

**Goals:** To find out the material properties of propylene in order to complete the materials design matrix and decide on a batten material.

**Content:**

- semi-rigid
- good chemical resistance --> not too important concerning muzzle
- tough
- good fatigue resistance --> ability to withstand numerous cycles of stress without breaking
- good heat resistance
- density - 905 kg/m<sup>3</sup>
- tensile strength - 33 MPa --> 31 N/mm<sup>2</sup>
- hardness - 90 (on Rockwell scale)
- Grades
  - homopolymers - general purpose
  - block copolymers - improved impact resistance and toughness
  - random copolymers - more flexible
- available at Makerspace
  - Ultimaker 3D printers
- can buy individual sheets and cut down to size --> freckleface.com (TeamLab recommendation)

**References:**

[1] "Polypropylene (PP)." <https://www.bpf.co.uk/plastipedia/polymers/pp.aspx> (accessed Oct. 16, 2020).

[2] "PP." <https://polymerdatabase.com/Commercial%20Polymers/PP.html> (accessed Oct. 16, 2020).

**Conclusions/action items:**

I will share this information to with my team to rate our Materials Design Matrix and decide on a batten material.



## 10/16/20 - Aluminum

---

ALEXANDRIA THAO - Dec 08, 2020, 9:55 PM CST

**Title:** Aluminum Material Properties

**Date:** 10/16/20

**Content by:** Alexandria Thao

**Present:** Alexandria Thao

**Goals:** To find the material and mechanical properties of aluminum in order to determine a batten material.

**Content:**

- density: 2.7 g/cm<sup>3</sup>
- Young's Modulus: 70 GPa
- Poisson Ratio: 0.33
- Tensile Strength: 47 MPa (pure aluminum)
- will form layer of (inert) aluminum oxide that will resist any rusting
- can resist water and salt corrosion (with proper treatment/coating) --> relevant to the possible drool and breath moisture that may accumulate on muzzle
- high electrical and thermal conductivity --> may be an issue with dog's body heat over long term use
- nonferromagnetic --> no worries of accidentally getting stuck to magnetic items
- non-toxic, regular use in food and beverage containers --> should be safe for use in muzzle

**References:**

[1] <https://materialsdata.nist.gov/bitstream/handle/11115/173/Aluminum%20and%20Aluminum%20Alloys%20Davis.pdf>

[2] "Aluminum." <http://www.mit.edu/~6.777/matprops/aluminum.htm> (accessed Oct. 16, 2020).

**Conclusions/action items:**

Aluminum may be a possible option for the supports that will be inserted into the muzzle. However, I am a bit worried about using metal in our project and will discuss with the team in our materials design matrix.



## 11/30/20 - Bone

ALEXANDRIA THAO - Dec 09, 2020, 11:23 AM CST

**Title:** Bone Physical Properties

**Date:** 11/30/20

**Content by:** Alexandria Thao

**Present:** Alexandria Thao

**Goals:** Compile information on the physical properties of bone in order to apply to FEA in SolidWorks.

**Content:**

- compact cortical bone -
  - tensile strength: 700-1400 kg/cm<sup>2</sup> (10,000-20,000 lb/in<sup>2</sup>)
  - compressive strength: 1400-2100 kg/cm<sup>2</sup> (20,000-30,000 lb/in<sup>2</sup>)
  - comparable to steel and aluminum, but much lighter
- modulus elasticity of bone: 420-700 kg/cm<sup>2</sup> (6000-10,000 lb/in<sup>2</sup>)
- Poisson ratio: 0.15-0.45 (in cortical bone) --> usually set at 0.3
- Young modulus: 20 GPa

**References:**

[1] "Bone - Chemical composition and physical properties," *Encyclopedia Britannica*. <https://www.britannica.com/science/bone-anatomy> (accessed Nov. 30, 2020)

[2] S. R. Davidson and D. F. James, "Measurement of thermal conductivity of bovine cortical bone," *Med Eng Phys*, vol. 22, no. 10, pp. 741–747, Dec. 2000, doi: [10.1016/s1350-4533\(01\)00003-0](https://doi.org/10.1016/s1350-4533(01)00003-0).

[3] F. Rupin *et al.*, "Experimental determination of Young modulus and Poisson ratio in cortical bone tissue using high resolution scanning acoustic microscopy and nanoindentation," *The Journal of the Acoustical Society of America*, vol. 123, no. 5, pp. 3785–3785, May 2008, doi: [10.1121/1.2935440](https://doi.org/10.1121/1.2935440).

**Conclusions/action items:**

I will input these values into SolidWorks to make a custom bone material for FEA when I attempt simulations on my own simplified mandible part.



## 9/17/20 - Suspension and Cantilever Bridge Mechanics

ALEXANDRIA THAO - Oct 05, 2020, 3:57 PM CDT

**Title:** Background on Suspension and Cantilever Bridge Mechanics

**Date:** 9/17/20

**Content by:** Alexandria Thao

**Present:** Alexandria Thao

**Goals:** To gain background knowledge of suspension and cantilever bridge mechanics

**Content:**

### Suspension Bridges

- carries vertical forces through curved cables (by tension)
- forces then transferred to:
  - towers - carry forces vertically to ground (by compression)
  - anchorages - resist inward (and vertical) pull of cables
- since deck is in air --> must be stiff and/or heavy in order to not move around
- towers are in compression
- deck hangs from cables in tension --> deck in tension and compression

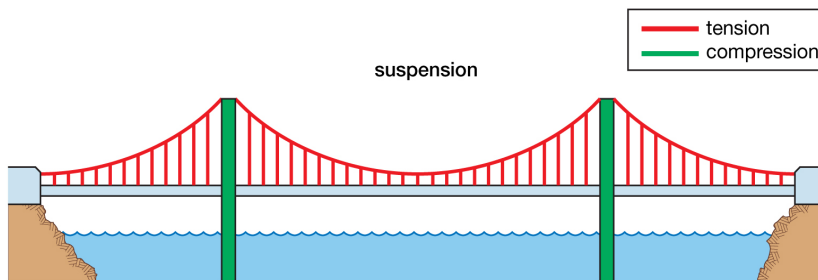

© 2012 Encyclopædia Britannica, Inc.

### Cantilever Bridges:

- generally made of three portions --> outer portion anchored and cantilevered (beam that projects outward and is only supported at one end)
- central portion rests on cantilevered outer parts
  - carries vertical forces --> tension forces in lower cord and compression in upper
- inner towers carry forces to foundation (by compression)
- outer towers carry forces to far foundations (by tension)
- tension above deck and compression below

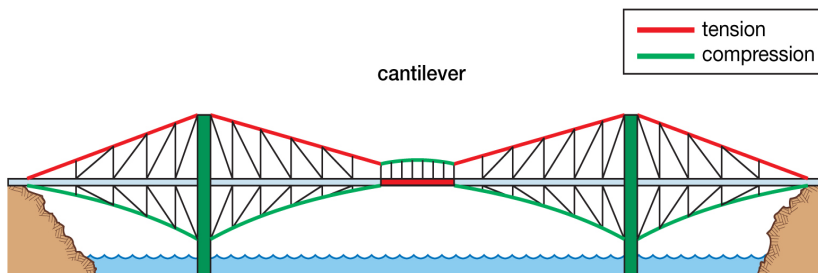

© 2012 Encyclopædia Britannica, Inc.

### References:

- [1] "Bridge - Truss," *Encyclopedia Britannica*. <https://www.britannica.com/technology/bridge-engineering> (accessed Sept. 17, 2020).

[2] B. Masters, "How it Works: Engineering Bridges to Handle Stress," *Bridge Masters*, Mar. 17, 2017. <https://bridgemastersinc.com/engineering-bridges-handle-stress/> (accessed Sept. 17, 2020).

**Conclusions/action items:**

I can use this information on bridge to understand how I can support the fracture in my initial muzzle designs. I will also look into how bridge mechanics are used in medicine and orthopedics already in order to cement my understanding.





## 10/5/20 - SolidWorks FEA

---

ALEXANDRIA THAO - Oct 05, 2020, 5:16 PM CDT

**Title:** Background on SolidWorks Finite Element Analysis (FEA)

**Date:** 10/5/20

**Content by:** Alexandria Thao

**Present:** Alexandria Thao

**Goals:** To be more familiar with SolidWorks FEA in order to help with 3D modeling of force distribution in our muzzle designs

**Content:**

- start with geometric model --> assign materials to components (in our case, nylon)
  - define forces on structure --> bite forces
  - apply restraints to show how part is anchored or held in place
1. Go to Add-ins --> SolidWorks Simulation
  2. Simulation window will be created --> New Study
  3. Go to "Part \_\_\_\_" --> Apply/edit materials
  4. Go to "Connections"
  5. Go to "Fixtures" --> fix a face so it doesn't move
  6. Go to "External Load" --> apply force and select direction of force
  7. Go to "Mesh" --> will divide part in multiple pieces, force applied on each individual part
  8. Run the study and animate
  9. Red to blue scale --> red shows areas of greatest stress

**References:**

[1] "Introduction to SOLIDWORKS Simulation - Finite Element Analysis," *SOLIDWORKS Tech Blog*, Jan. 09, 2020. <https://blogs.solidworks.com/tech/2020/01/introduction-to-solidworks-simulation-finite-element-analysis.html> (accessed Oct. 05, 2020).

[2] *SolidWorks Simulation tutorial for Beginners*. 2017.

**Conclusions/action items:**

I will try out the SolidWorks FEA on simple parts going off of the demos I have watched and read.



## 9/23/20 - Initial Design Sketches

ALEXANDRIA THAO - Oct 05, 2020, 1:43 PM CDT

**Title:** Initial Design Sketches

**Date:** 9/23/20

**Content by:** Alexandria Thao

**Present:** Alexandria Thao

**Goals:** Create initial design sketches to share with the team in order to create our design matrix.

**Content:**

- Design 1 - has open sides for better breathability (?)
  - possibly have mesh on sides
- Design 2 - similar appearance to arm pressure band
  - nylon cloth will wrap around and strap with velcro (?)
  - less breathability
- Design 3 (Mesh) - combination of mesh and nylon material
  - better breathability
- Design 4 (Zipper) - features zipper along sides of mouth to allow more movement; for eating and drinking
- All designs will likely be made of nylon with batten supports running laterally through fabric.
- Possibly add padding where battens or straps are



**Conclusions/action items:**

I will share my designs with the team in preparation for our design matrix. I will also clean up my design sketches if necessary.

# 10/1/20 - Fabrication Plan

ALEXANDRIA THAO - Nov 13, 2020, 1:36 PM CST

**Title:** Fabrication Plan

**Date:** 10/1/20

**Content by:** Alexandria Thao and Sydney Appleton

**Present:** Alexandria Thao and Sydney Appleton

**Goals:** Create a basic fabrication plan and design as well as research on where to procure materials

**Content:**

## Fabrication Plan

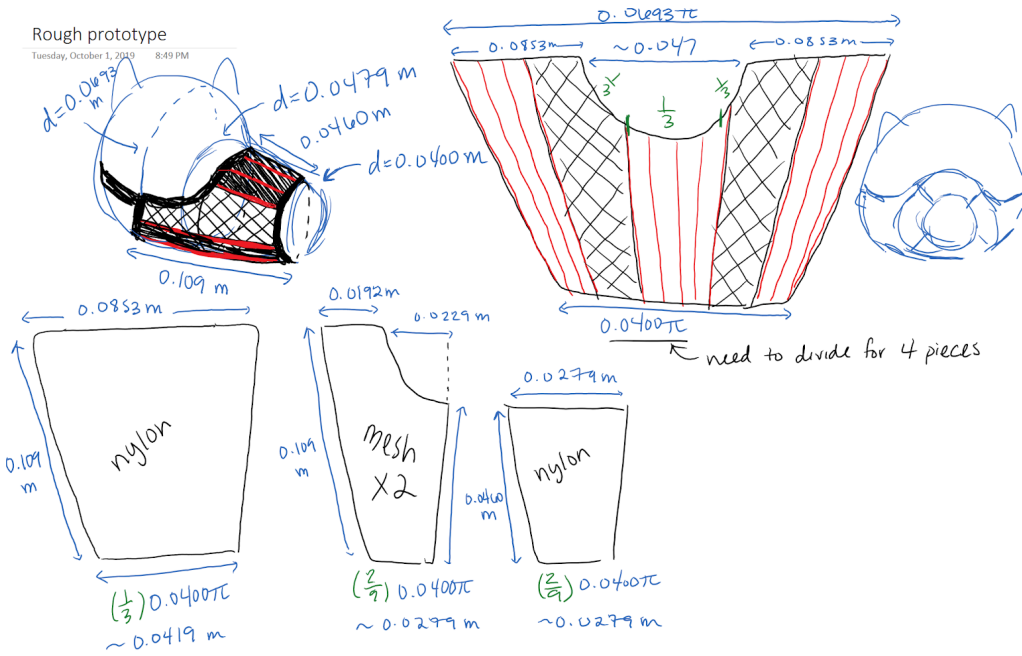

- 4 separate pieces sewn together → 1 bottom nylon piece, 1 top nylon piece, 2 side mesh pieces
- Need to add on few mm to account for muscle, skin, and fur → also need to add extra mm hem allowance

## Where to purchase and prices?

### Polyamide

- Sheets available from:
  - midland plastics or fleckleface.com (TeamLab suppliers)
  - Shop@UW from Fischer Scientific
- Can be 3D printed at Makerspace using Ultimaker printers → \$0.12 per gram

### Polypropylene

- Sheets available from:
  - midland plastics or fleckface.com
- Can be 3D printed at Makerspace using Ultimaker printers → \$0.13 per gram

### Aluminum

- Can buy sheets on Shop@UW from WW Grainger
- Can buy sheets on Shop@UW from MSC Industrial Supply Co.

#### Nylon

- Mesh sheets available on (non-Shop@UW):
  - <https://www.fabricwholesaledirect.com/products/power-mesh-fabric?variant=11088926470> (\$3.99/yd)
  - Performance Nylon Spandex Power Mesh Fabric Black at JoAnn's \$8.99/yd (minimum 2 yards)
  - Solid Power Mesh Fabric Nylon Spandex - FWD on Amazon (1 yd - \$6.99)
- Non-Mesh sheets:
  - [Ripstop Nylon Fabric 59" Solids](#)
- Other
  - Nylon straps - [Joann's](#)
  - Buckle - [Joann's](#)
- **Optional** - corset bone casing to insert supports into, no need to make own folds in muzzle
  - Polyester bone casing - \$8.99 from [Amazon](#)

#### Conclusions/action items:

We will go over with the whole team on this plan and finalizing purchase sites and prices.



## 11/3/20 - SolidWorks Muzzle

ALEXANDRIA THAO - Dec 08, 2020, 10:08 PM CST

**Title:** Prototype muzzle design in SolidWorks

**Date:** 11/3/20

**Content by:** Alexandria Thao

**Present:** Alexandria Thao

**Goals:** Create a simplified muzzle design in SolidWorks primarily for image and presentation purposes

**Content:**

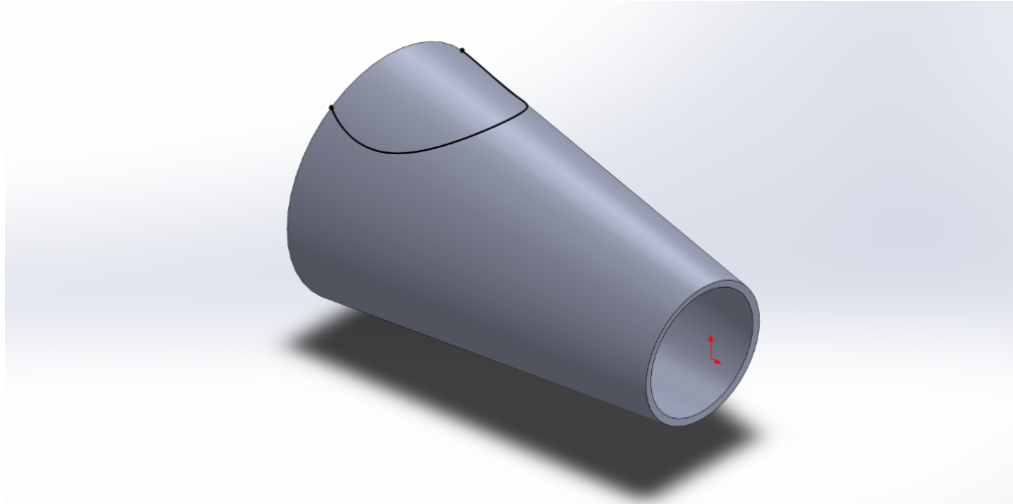

**References:**

SolidWorks Tutorial Sheet Metal Cone - <https://www.youtube.com/watch?v=Dlp33jPUNSS&t=331s>

SolidWorks Revolved Cut Tutorial - <https://www.youtube.com/watch?v=CDPlm0I734k>

Extruded Boss on Nonplanar Surface - <https://www.youtube.com/watch?v=Dlp33jPUNSS&t=331s>

Sheet Metal Cone - <https://www.youtube.com/watch?v=OQvaElw04Xo>

**Conclusions/action items:**

My design is currently incomplete, but since Arrington has a finalized CAD model of our muzzle the team will use that instead. If I were to continue work on this, I would like to add a strap around the head as well as lay it out flat for fabrication purpose.



## 11/30/20 - Simplified Jaw Part

ALEXANDRIA THAO - Dec 08, 2020, 8:37 PM CST

**Title:** Simplified Jaw Part in SolidWorks

**Date:** 11/30/20

**Content by:** Alexandria Thao

**Present:** Alexandria Thao

**Goals:** To create a simple jaw part in SolidWorks to attempt FEA on.

**Content:**

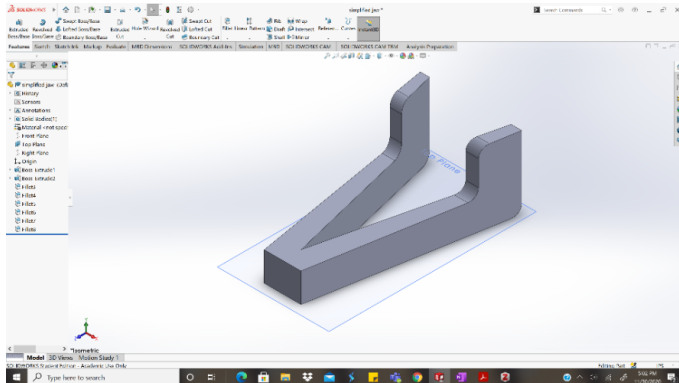

\*dimensions based off 3D scan of dog skull

**Conclusions/action items:**

I will continue to work on this model and attempt to perform FEA on it.



## 9/9/20 - Mandibular Fracture Repair in Dogs

JAKOB KNAUSS - Dec 09, 2020, 10:46 AM CST

**Title:** Mandibular Fracture Repair in Dogs

**Date:** 09/09/2020

**Content by:** Jakob Knauss

**Present:** Jakob Knauss

**Goals:** Background Research on Project

**Content:**

Mandibular fractures in canines often occur at the mandibular carnassial tooth (M1) (see Figure 1), an area that is specifically weak as a result of the large volume of M1 relative to the mandibular bone. An alternative and less expensive treatment involves the use of a tape muzzle (see Figure 2). The tape muzzle can be made readily with bandaging tape, and it is inexpensive and disposable after use. The tape muzzle is designed to allow a 0.5 to 1.0 cm (up to 1.5 cm) gap in the incisors, so the dog is able to drink water and eat soft food. The head strap then extends behind the ears to keep the muzzle from moving. Although the tape muzzle is widely used in practice, it has several inherent flaws that are overlooked by veterinary professionals. For example, the oral tissues, with its rich blood supply and lack of heavy weight bearing, does not need complete rigid fixation for adequate healing, though the callus formation will be larger in areas that are not totally immobilized. An alternative to the tape muzzle is a standard cloth, nylon, or mesh muzzle (see Figure 3). These muzzles are designed to form a sling that is more likely to cradle the mandibles on either side of the fracture site and are easy to remove with a buckle latch.

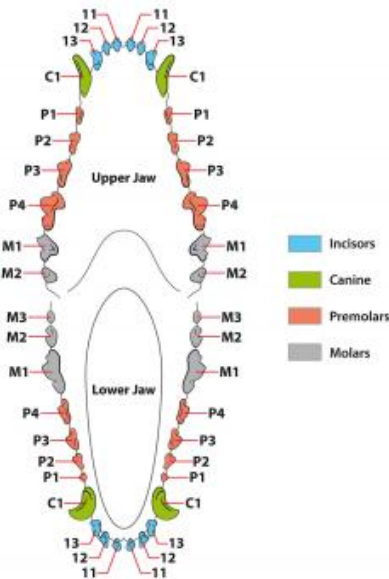

Figure 1: Dog Tooth Diagram



Figure 2: Tape Muzzle



Figure 3: Nylon Muzzle

**References:** <https://bmedesign.engr.wisc.edu/selection/projects/fdef3f4b-e9d1-46ee-b680-2b839deb7360>

- [1] Lopes FM, Gioso MA et al. Oral fractures in dogs of brazil- a retrospective study. *J Vet Dent.* 2005;22(2):86-90.
- [2] Soukup J, Mulherin BM, Snyder CJ. Prevalence and nature of dentoalveolar injuries among patients with maxillofacial fractures. *J Small Anim Pract.* 2013;54(1):9-14.
- [3] Kitshoff AM, de Rooster H, Ferreira SM, Steenkamp G. A retrospective study of 109 dogs with mandibular fractures. *Vet Comp Orthop Traumatol.* 2013;26(1):1-5.
- [4] Umphlet R, Johnson A. Mandibular fractures in the dog, a retrospective study of 157 cases. *Vet Surg.* 1990; 19: 272-275.
- [5] Verstraete FJ, Lighthelm AJ. Dental trauma caused by screws in internal fixation of mandibular osteotomies in the dog. *Vet Comp Orthop Traumatol.* 1992;5:104-108
- [6] Kern DA, Smith MM et al. Evaluation of bending strength of five interdental fixation apparatuses applied to canine mandibles. *Am J Vet Res.*1993;54(7):1177-8.
- [7] Withrow, S.J. (1981). Taping of the mandible in treatment of mandibular fractures. *J. Am. Anim. Hosp. Assoc.* 17: 27.



[8] Smith, M.M. and Legendre, L.F.J. (2012). Maxillofacial repair using noninvasive techniques. In: Oral and Maxillofacial Surgery in Dogs and Cats, 1e (ed. F.J.M. Verstraete and M.J. Lommer), 275–284. Edinburgh, UK: Saunders Elsevier.

[9] Snyder C.J. Maxillofacial Fracture Repair Using Noninvasive Techniques. In: Oral and Maxillofacial Surgery in Dogs and Cats 2nd ed (ed. F.J.M. Verstraete, M.J. LommerArzi B), 297-308. Edinburgh, UK: Saunders Elsevier.

[10] Manfra Marretta, S., Schrader, S.C., and Matthiesen, D.T. (1990). Problems associated with the management and treatment of jaw fractures. *Probl. Vet. Med. Surg. Dent.* 2: 220.

**Conclusions/action items:** Our group needs to find ways to test and measure the stresses on the nylon muzzle as well as its ability to support the jaw.

**9/16/20 - Forces on the Mandible**

JAKOB KNAUSS - Dec 09, 2020, 10:46 AM CST

**Title:** Forces on the Mandible

**Date:** 9/16/20

**Content by:** Jakob Knauss

**Present:** N/A

**Goals:** Find the maximum force exerted on the dog's jaw from biting.

**Content:**

Bite forces were estimated based on two different lever models, which are based on the principle of lever mechanics. Both involve making estimates of the force generated by the jaw muscles (based on differing estimates of the effective are of muscle cross section), and the leverage of that force about the point of biting. The forces of biting were estimated at two locations, immediately behind the canine (CBF, canine bite forces) and at the junction of M1 and M2 on the mandible (MBF = molar bite forces). Skull size and shape had an impact on the bite force of the dog, with bigger dogs having a greater bite force. The maximum bite force measured was approximately 5000 N. This is a very important piece of our product design specifications. [1]

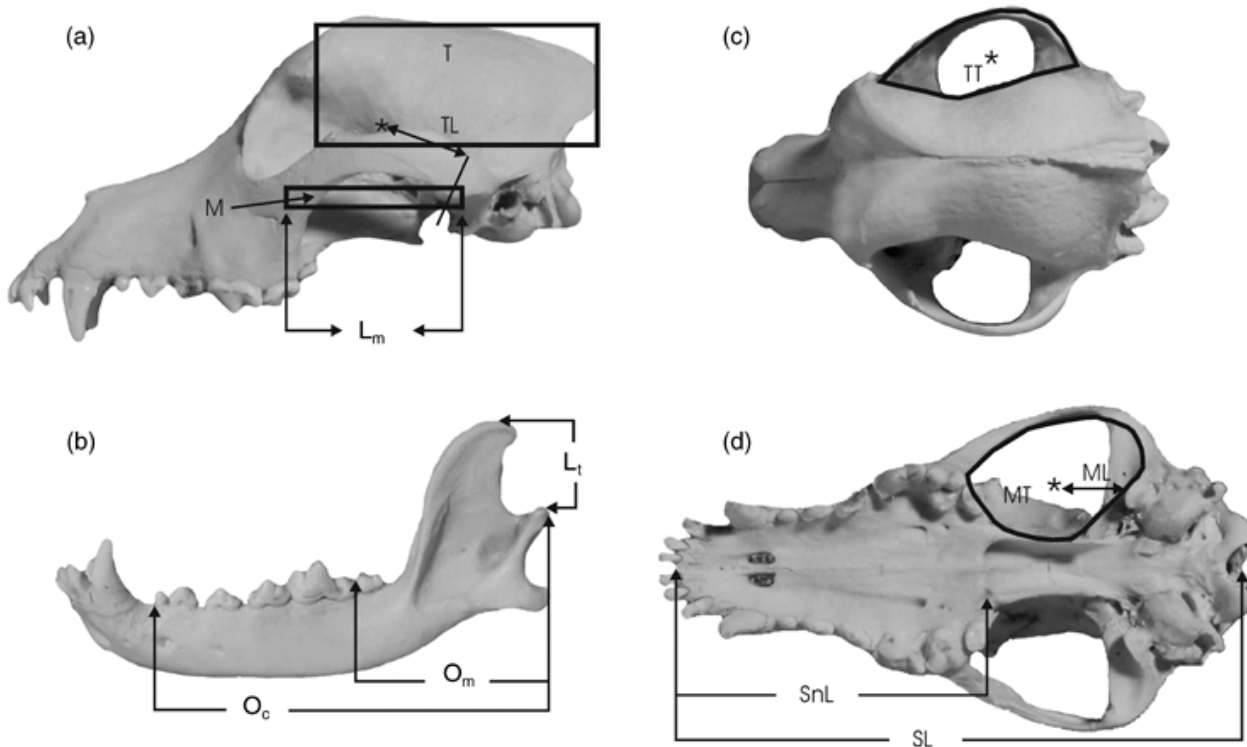

Figure 1: Different views showing important dimensions of dog skull

From another source, these were some of the estimated bite force values for dogs at different locations. It is clear that the bite force can vary greatly, but it is good to note the ranges on different parts of the mandible. [2]

Table 1: Bite forces at different locations

Animal	Measured/ estimated location	Bite force (Newton, N)	Measurement/ estimation method
Dog	Not specified	13–1,394	Measured by chewing transducer rolled with the rawhide (22)
	Canine teeth	147–926	Maximum bite force measurement by electronic stimulations (26)
	Molar teeth	574–3,417	
	Canine teeth	300*	Bite force estimation using equations of Kiltie (27) Thomason (28) Kiltie (26) (adjusted) Thomason (26) (adjusted)
		340*	
		571*	
		588*	
Molar teeth	755*	Kiltie (27) Thomason (28) Kiltie (26) (adjusted) Thomason (26) (adjusted)	
	849*		
	1,949*		
	2,036*		
Canine teeth	351.5*	Bite force estimation using Thomason's equation (29)	
	Carnassial teeth		549.8*
Canine teeth	231.99–511.80 <sup>a</sup>	Bite force estimation using finite element analysis (35)	
	Carnassial teeth		620.33–1,091.1 <sup>b</sup>
Cat	Canine teeth	73.3*	Maximal bite force estimation using Thomason's equation (29)
	Carnassial teeth	118.1*	

\*Values are the average of measured/estimated bite force.

<sup>a,b</sup>Various estimated bite forces according to the gape angles between 5 and 65°.

#### References:

- [1] J. L. Ellis, J. Thomason, E. Kebreab, K. Zubair, and J. France, "Cranial dimensions and forces of biting in the domestic dog," *Journal of Anatomy*, vol. 214, no. 3, pp. 362–373, 2009.
- [2] S. E. Kim, B. Arzi, T. C. Garcia, and F. J. M. Verstraete, "Bite Forces and Their Measurement in Dogs and Cats," *Frontiers in Veterinary Science*, vol. 5, 2018.

**Conclusions/action items:** We need to factor this information into our design and figure out how our design will support and distribute the force.



## 10/14/20 - Polypropylene Material Properties

JAKOB KNAUSS - Dec 09, 2020, 10:54 AM CST

**Title:** Polypropylene Material Properties

**Date:** 10/16/20

**Content by:** Jakob Knauss

**Present:** N/A

**Goals:** Research materials to be used in our design.

**Content:**

### Polypropylene

- a rigid and crystalline thermoplastic used widely in everyday objects like packaging trays, household products, battery cases, medical devices, etc.
- melting point - occurs at a range
  - homopolymer (160 - 165°C), copolymer (135 - 159°C)
- density - PP is one of the lightest polymers among all commodity plastics, making it a suitable option for lightweight applications
  - homopolymer (0.904 – 0.908 g/cm<sup>3</sup>), random copolymer (0.904 – 0.908 g/cm<sup>3</sup>), impact copolymer (0.898 – 0.900 g/cm<sup>3</sup>)
- chemical resistance - excellent resistance to diluted and concentrated acids, alcohols and bases; good resistance to aldehydes, esters, aliphatic hydrocarbons, ketones; limited resistance to aromatic and halogenated hydrocarbons and oxidizing agents
- flammability - highly flammable material
- disadvantages: poor resistance to UV, impact and scratches; embrittles below -20°C; low upper service temperature, 90-120°C; attacked by highly oxidizing acids, swell rapidly in chlorinated solvents and aromatics; heat-aging stability is adversely affected by contact with metals [1]

**References:**

[1] "The Definitive Guide to Polypropylene (PP)." Polypropylene (PP) Plastic: Types, Properties, Uses & Structure Info. <https://omnexus.specialchem.com/selection-guide/polypropylene-pp-plastic> (accessed Oct. 14, 2020).

**Conclusions/action items:** Fill in the materials design matrices based on the findings of this research.



# 10/14/20 - Nylon Material Properties

**Title:** Nylon Material Properties

**Date:** 10/16/20

**Content by:** Jakob Knauss

**Present:** N/A

**Goals:** Research materials to be used in our design.

**Content:**

Nylon (Polyamide)

- semi-crystalline and generally very tough materials with good thermal and chemical resistance
- tend to absorb moisture from their surroundings
- tend to provide good resistance to most chemicals, however can be attacked by strong acids, alcohol's and alkalis
- can be used in high temperature environments
- many types of nylon available (e.g. nylon 6 nylon 66, nylon 6/6-6, nylon 6/9, nylon 6/10, nylon 6/12, nylon 11, nylon 12)
- available as a homopolymer, co-polymer or reinforced
- physical properties:
  - tensile strength 90 - 185 N/mm<sup>2</sup>
  - notched impact strength: 5.0 - 13 Kj/m<sup>2</sup>
  - thermal coefficient of expansion: 90 - 20/70 x 10<sup>-6</sup>
  - max cont use temp: 150 - 185 oC
  - density: 1.13 - 1.35/1.41 g/cm<sup>3</sup> [1]
- exceptionally strong and elastic and stronger than polyester fibers
- excellent toughness, abrasion resistance, and are easy to wash, and to dye in a wide range of colors
- filament yarns provide a smooth, soft, and lightweight fabric of high resilience

Table 1: Nylon fiber properties

## NYLON FIBER PROPERTIES

Tensile Strength (Tenacity)	Excellent
Abrasion Resistance	Excellent
Absorbency	Fair
Static Resistance	Fair - Poor
Heat Resistance	Fair
Wrinkle Resistance	Good - Excellent
Resistance to Sunlight	Poor
Elasticity	Excellent
Flame Resistance	Does Not Burn
Resilience	Excellent

[2] [3]

Table 2: Nylon vs. Nylon 6/6 properties

	Nylon 6	Nylon 6/6
<b>Machinability – low tool wear &amp; surface finish</b>	<b>Good</b>	<b>Better</b>
<b>Mould shrinkage</b>	<b>Lower</b>	<b>Greater</b>
<b>Water absorption rate</b>	<b>Higher</b>	<b>Lower</b>
<b>Impact strength</b>	<b>Izod: cm-N/cm of notch: 160</b>	<b>Izod: cm-N/cm of notch: 160</b>
<b>Tensile strength</b>	<b>6.2 x 104 kPa (Good)</b>	<b>8.2 x 104 kPa (Better)</b>
<b>Crystalline melting point</b>	<b>437°F / 225°C</b>	<b>509°F / 265°C</b>
<b>Density</b>	<b>1.15 g/ml</b>	<b>1.2 g/ml</b>
<b>Typical moulding shrinkage ratio</b>	<b>1.2%</b>	<b>1.5%</b>

[4]

Table 3: Nylon 6 vs. Nylon 66 properties

NYLON 6	NYLON 66
Less crystalline	More crystalline
Lower mold shrinkage	Exhibits greater mold shrinkage
Lower melting point	Higher melting point
Lower heat deflection temperature	Higher heat deflection temperature
Higher water absorption rate	Lower water absorption rate
Poor chemical resistance to acids	Better chemical resistance to acids
Withstands high impact and stress and better stands up to hydrocarbons	Better stiffness, tensile modulus and flexural modulus
Lustrous surface finish, easy to colour	More difficult to colour

[5]

**References:**

[1] "Nylons (Polyamide)." British Plastics Federation. <https://www.bpf.co.uk/plastipedia/polymers/polyamides.aspx#:~:text=to%20buy%20polyamides%3F-,PROPERTIES,as%20the%20nylon%20number%20increases.> (1 2020).

[2] "Nylon Fibers." Polymer Properties Database. <https://polymerdatabase.com/Fibers/Nylon.html#:~:text=Nylon%20fibers%20are%20exceptionally%20strong,lightweight%20fabric%20of%20high%20resilience.> (retrieved Oct. 14, 2020).

[3] Boris Hodakel. "What is Nylon Fabric: Properties, How its Made and Where." Sewport. <https://sewport.com/fabrics-directory/nylon-fabric> (retrieved Oct. 14, 2020).

[4] "The differences between nylon 6 and nylon 6/6." Essentra Components. <https://www.essentracomponents.com/en-gb/news/guides/the-differences-between-nylon-6-and-nylon-6/6#:~:text=Nylon%206%20is%20derived%20from,is%20made%20from%20two%20monomers.&text=As%20you'd%20expect%2C%20nylon,stiffer%20and%20usually%20more> (retrieved Oct. 14, 2020).

[5] "NYLON 6 OR NYLON 66 - WHICH ONE SHOULD I CHOOSE?" Ai Engineering Plastics & Laminates. <https://www.aiplastics.com/blog/nylon-6-or-nylon-66/> (accessed Oct. 14 2020).

**Conclusions/action items:** Fill in the materials design matrices based on the findings of this research.



## 10/14/20 - Mesh Material Properties

---

JAKOB KNAUSS - Dec 09, 2020, 10:49 AM CST

**Title:** Mesh Material Properties

**Date:** 10/16/20

**Content by:** Jakob Knauss

**Present:** N/A

**Goals:** Research materials to be used in our design.

**Content:**

### Mesh

- Nylons are formed by extracting carbon-based molecules from organically formed resources such as petroleum or coal. These are combined into a larger polymer molecule using heat, resulting in a polyamide. The family of polyamides created in this way is known collectively as nylon. Nylon mesh fabrics are used for applications that require versatility, durability, and strength. The innate chemical properties of this polyamide make its fibers resistant to wear from bending or stretching. Nylon has a smoother, softer feel than polyester, making it ideal for applications where comfort or aesthetics are essential. Both materials stretch, but the elastic properties of nylon are greater than those of polyester. Nylon is also hydrophilic, which means that it absorbs water.
- Polyester is one of the most commonly used plastics. It is made by facilitating a chemical reaction between alcohol, a petroleum by-product, and carboxyl acid in a vacuum. This creates a polymer that can be stretched and made into fabrics. Polyester mesh fabrics can be more easily dyed because they are hydrophobic—they repel water. As such, the material absorbs the pigments in the dye while expelling the water. This property also means polyester dries faster than nylon, making it ideal for marine environments. Polyester is also more naturally flame resistant than nylon, and also features a higher resistance to UV degradation. [1]
- Different Types of Mesh [2] [3]

### **References:**

[1] "Mesh Fabrics: Knitting and Finishing Nylon and Polyester Mesh and Netting." Jason Mills. <https://www.jasonmills.com/blog/index.php/2019/11/11/mesh-fabrics/#:~:text=When%20knitted%20into%20mesh%20fabrics,wear%20from%20bending%20or%20stretching.> (accessed Oct. 14, 2020).

[2] "Mesh Fabrics." Seattle Fabrics. [https://www.seattlefabrics.com/Mesh-Fabrics\\_c\\_23.html](https://www.seattlefabrics.com/Mesh-Fabrics_c_23.html) (accessed Oct. 14, 2020).

[3] "Woven Mesh." Industring Netting. <https://www.industrialnetting.com/woven-mesh.html> (accessed Oct. 14, 2020).

**Conclusions/action items:** Fill in the materials design matrices based on the findings of this research.



## 10/14/20 - Thermoplastics Material Properties

---

JAKOB KNAUSS - Dec 09, 2020, 10:49 AM CST

**Title:** Thermoplastics Material Properties

**Date:** 10/16/20

**Content by:** Jakob Knauss

**Present:** N/A

**Goals:** Research materials to be used in our design.

**Content:**

Thermoplastics

- Engineering Thermoplastics—Materials, Properties, Trends [1]

**References:**

[1] Applied Plastics Engineering Handbook, 2nd ed., SABIC, Selkirk, NY, 2017, pp. 3-26.

**Conclusions/action items:** Fill in the materials design matrices based on the findings of this research.





## 10/7/20 - Cantilever Mechanics

---

JAKOB KNAUSS - Dec 09, 2020, 10:55 AM CST

**Title:** Cantilever Mechanics

**Date:** 10/7/20

**Content by:** Jakob Knauss

**Present:** N/A

**Goals:** Gain more knowledge about cantilever mechanics and how they will contribute to our design.

**Content:**

Cantilevers are rigid structures, such as beams, which are fixed at one end and free at the other end. Some cantilevers can be supported throughout their length by trusses or cables. When a load is applied to the cantilever the cantilever transfers that load to the fixed end by bending. [1]

A cantilever is any piece of wire which is attached to a removable appliance and the end is tied to another unit. When an orthodontist uses a cantilever, they can easily estimate the force applied, simply by measuring the length of the appliance and its force through a dynamometer. This aids in the prediction of clinical results.

- combination of a moment and a force is produced at the site where the cantilever is inserted
- single force is developed with respect to the point of the force application of the other end
- overall magnitude of the two forces is both equal and opposite based on Newton's third law
- $M = F \times d$
- cantilever deactivation, high level of constancy with the moment/force ratio
- cantilever should remain in place for as long as possible
- the load or deflection ratio which is delivered by a cantilever should remain as low as possible, allowing the force system to maintain a high degree of constancy [2]

**References:**

[1] "Cantilever: Definition & Terminology." Study.com. <https://study.com/academy/lesson/cantilever-definition-terminology.html> (accessed Oct. 7, 2020).

[2] "Ortho Procedures - Cantilever Mechanics." Pan Orthodontics. [panorthodontics.com/procedures-cantilever-mechanics/](http://panorthodontics.com/procedures-cantilever-mechanics/) (accessed Oct. 7, 2020).

**Conclusions/action items:** Apply knowledge of cantilever mechanics to forces on the mandible and what support is needed.



## 9/23/20 - Preliminary Design

JAKOB KNAUSS - Dec 09, 2020, 9:06 AM CST

**Title:** Preliminary Design Drawing

**Date:** 9/23/20

**Content by:** Jakob Knauss

**Present:** N/A

**Goals:** Brainstorm Ideas for Our Preliminary Design

**Content:** Similar to the ideas of other team members.

**Conclusions/action items:** Decide on three designs to put in our design matrix to be compared to the tape muzzle.

JAKOB KNAUSS - Dec 09, 2020, 10:32 AM CST

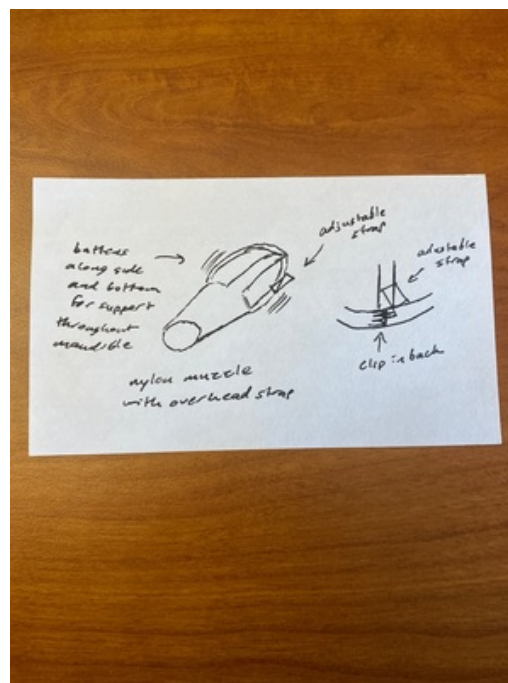

Preliminary\_Design\_Drawing.jpg(627.4 KB) - [download](#) Figure 1: Preliminary Design Drawing



# 10/28/20 - Jaw Model Hand Calculations

JAKOB KNAUSS - Dec 09, 2020, 9:06 AM CST

**Title:** Preliminary Design Drawing

**Date:** 10/28/20

**Content by:** Jakob Knauss

**Present:** N/A

**Goals:** Perform Hand Calculations for a Simplified Model of the Mandible

**Content:**

I performed hand statics calculations to understand the distribution of force throughout the mandible and find values for the stresses caused by the bite forces. I could only get results for the unsupported model because the two supported models (tape muzzle and nylon muzzle) were statically indeterminate.

My calculations matched with Arrington's when we compared them.

**Conclusions/action items:** Compare these results to our FEA findings.

JAKOB KNAUSS - Dec 09, 2020, 10:32 AM CST

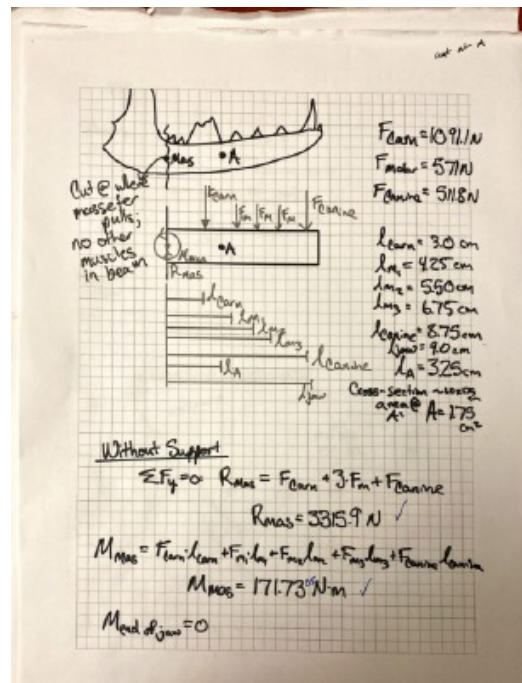

JawHandCalcs.pdf(5.6 MB) - [download](#) Figure 1: Jaw Model Hand Calculations



## 10/21/20 - 3D Scans

JAKOB KNAUSS - Dec 09, 2020, 10:38 AM CST

**Title:** 3D Scans

**Date:** 12/9/20

**Content by:** Jakob Knauss

**Present:** Arrington, Kate, and Alex

**Goals:** Get Detailed Scans of the Skulls to Perform Accurate FEA Analysis

**Content:** We went to the Makerspace to get 3D scans of the skull that Dr. Thatcher gave us.

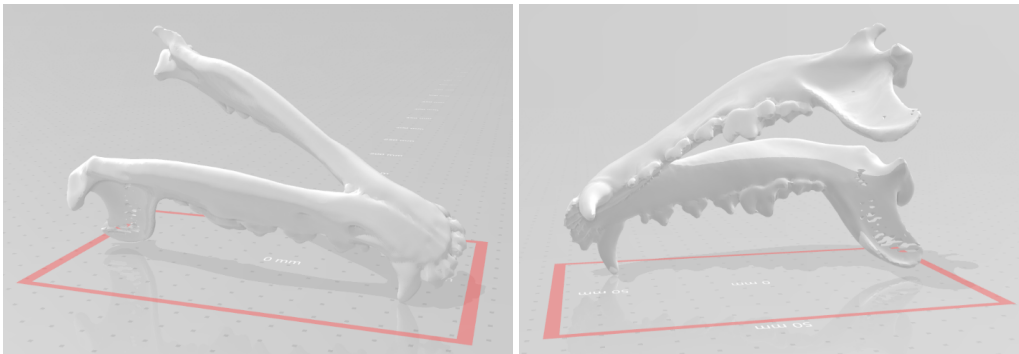

Figure 1: Two views of the 3D scan

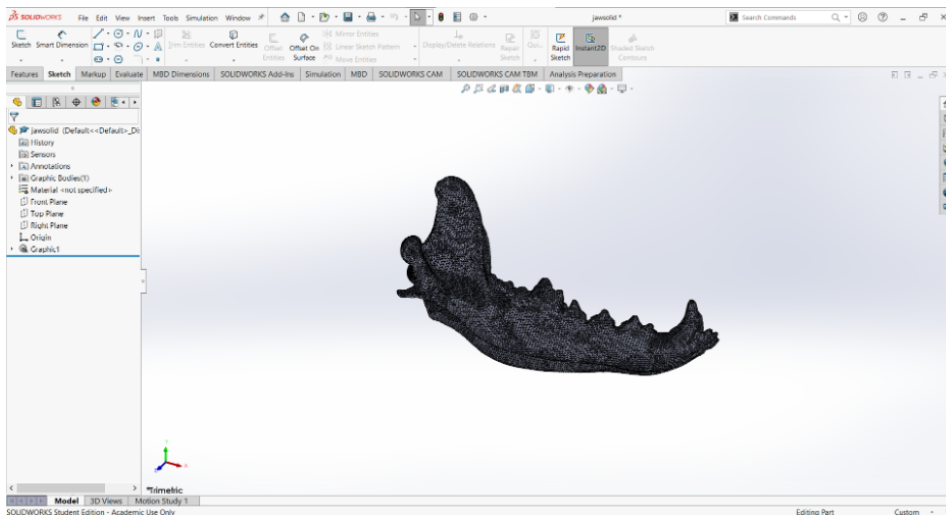

Figure 2: 3D scan in SolidWorks

**Conclusions/action items:** Use 3D scans to perform finite element analysis.



# 11/12/20 - SolidWorks Tutorial Videos

JAKOB KNAUSS - Dec 09, 2020, 10:39 AM CST

**Title:** SolidWorks Tutorial Videos

**Date:** 11/12/20

**Content by:** Jakob Knauss

**Present:** N/A

**Goals:** Familiarize Myself With SolidWorks

**Content:**

I watched a few videos from LinkedIn Learning to familiarize myself with the software, so I can assist the team with our SolidWorks troubles. I messed around and created this part. Hopefully, I will be able to create a simplified model of the dog mandible.

Section	Lesson/Quiz	Status	Duration
Introduction	Learn 3D CAD modeling using SOLIDWORKS 2020	Completed	1m 1s
	1. Introduction to SOLIDWORKS	Completed	-
1. Introduction to SOLIDWORKS	Launching SOLIDWORKS for the first time	Completed	4m 29s
	Navigating in the 3D workspace	Completed	6m 20s
	SOLIDWORKS templates	Completed	4m 46s
	Saving, renaming, and managing files	Completed	4m 40s
	Measuring	Completed	2m 8s
	Chapter Quiz	Completed	5 questions
	2. SOLIDWORKS Quick Start	Completed	-
2. SOLIDWORKS Quick Start	Creating your first 3D part	Completed	6m 20s
	Building your first assembly	Completed	4m 35s
	Making your first CAD drawing	Completed	5m 15s
	Basic steps for 3D modeling	Completed	6m 59s
	Chapter Quiz	Completed	4 questions

Figure 1: SOLIDWORKS 2020 Essential Training Course

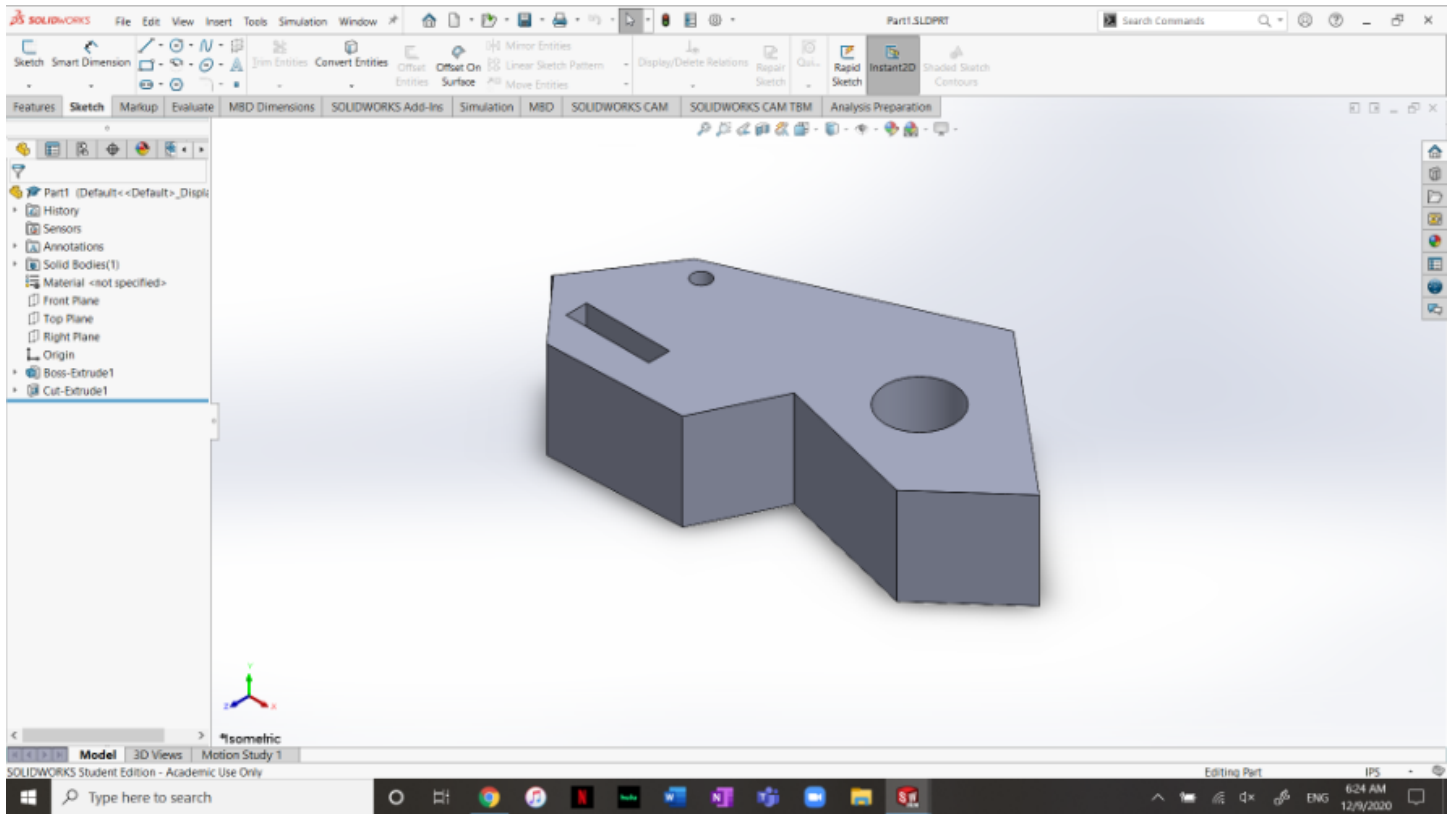

Figure 2: SolidWorks Part

**Conclusions/action items:** Use some of this basic knowledge to create a simplified jaw model for FEA.



## 11/18/20 - Attempt at SolidWorks Muzzle Design

JAKOB KNAUSS - Dec 09, 2020, 9:06 AM CST

**Title:** Attempt at SolidWorks Muzzle Design

**Date:** 11/18/20

**Content by:** Jakob Knauss

**Present:** N/A

**Goals:** Create a Resemblance of the Muzzle in SolidWorks

**Content:**

I watched some videos trying to figure out how to make a hollow cone shape in SolidWorks. I didn't get too far, but I gained some more experience with SolidWorks.

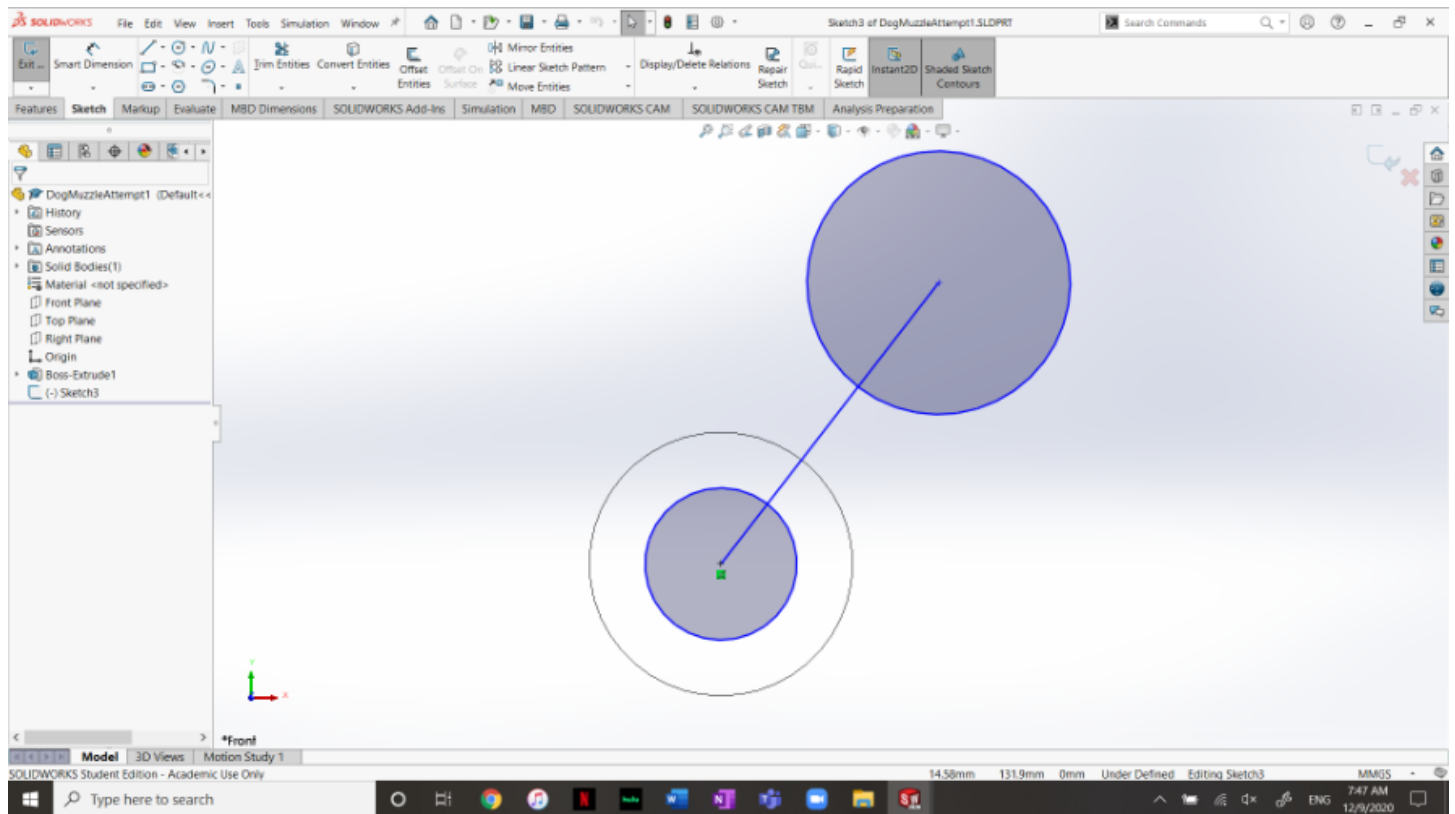

**Conclusions/action items:** See how other people's drawings looked and what strategies they used.

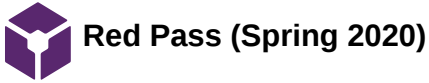

Google Calen... Inter Egr 170 S... INTEREGR170... INTEREGR 170... PowerPoint P... Library Resou... Scopus - Docu... Advanced Ser... Mail - JAKOB... +

outlook.office365.com/mail/search/fd/AAQkADA1OTyOWUxLTmWwNWYtNDAM1hMjkzLTNkMDM3ZmNmNGQ5MQAQAMM5ctbAF8-InxWKFNsLNMY%3D

MyUW Canvas Outlook Email Gmail Google Calendar College - Freshman... UW G Suite Kines Textbook STAT 311 Cengage ESPN TV fuboTV Swansoo FGR Hulu Netflix

**WISCONSIN** UNIVERSITY OF WISCONSIN - MADISON All red permit

New message Delete Archive Junk Move to Categorize

**Results**

**Top results**

- teamlab@enr.wisc.edu Registered for Fabricatio... Wed 1/22 You are registered for the Red P... [Inbox]
- teamlab@enr.wisc.edu Upcoming Fabrication La... Tue 1/28 Jakob Knauss, 'You are registere... [Inbox]
- teamlab@enr.wisc.edu Upcoming Fabrication La... Mon 1/27 Jakob Knauss, 'You are registere... [Inbox]

**All results**

- teamlab@enr.wisc.edu Upcoming Fabrication La... Tue 1/28 Jakob Knauss, 'You are registere... [Inbox]
- teamlab@enr.wisc.edu Upcoming Fabrication La... Mon 1/27 Jakob Knauss, 'You are registere... [Inbox]
- INTEREGR 170:LAB307 SP20 Inter Egr 170, Lab 307: W... Thu 1/23 Good morning: Welcome to Int... [Inbox]

**Registered for Fabrication Lab Seminar**

teamlab@enr.wisc.edu  
Wed 1/22/2020 10:13 AM  
JAKOB ANTHONY KNAUSS

You are registered for the Red Permit Seminar to take place on Tue, 01/28/2020 at 7:00 PM in TEAM Lab. The seminar will be taught by JAY BOWE

If, for any reason, you will not be able to attend, you must cancel your registration at least 24 hours prior to the seminar. If you will not be able to attend, and it is less than 24 hours prior to the seminar, you must contact the staff.

Please remember to arrive wearing safe clothing. See <https://teamlab.engr.wisc.edu/about/policies>

**Policies – TEAM Lab – UW–Madison**

The policies below are meant to ensure safe practices within the fabrication labs of the College of Engineering (CoE). These rules will be enforced and non-compliance will result in the suspension of lab privileges and/or disciplinary action.

teamlab.engr.wisc.edu

Sincerely,  
TEAM Lab Staff

Phone: (608) 261-1112  
Fax: (608) 261-1111  
E-mail: teamlab@enr.wisc.edu  
teamlab@enr.wisc.edu



**9/10/2020 General Background Research**

MATTHEW WROBLEWSKI - Dec 09, 2020, 9:10 AM CST

**Title:** General background research

**Date:** 9/10/2020

**Content by:** Matthew Wroblewski

**Present:** N/A

**Goals:** Increase general understanding of the project through research on relevant articles

**Content:**

See project overview for comprehensive description and background information

Canine dental anatomy:

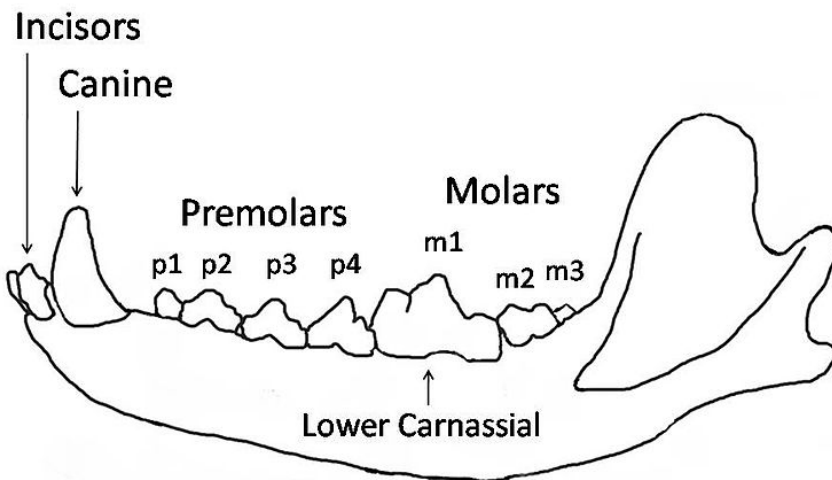
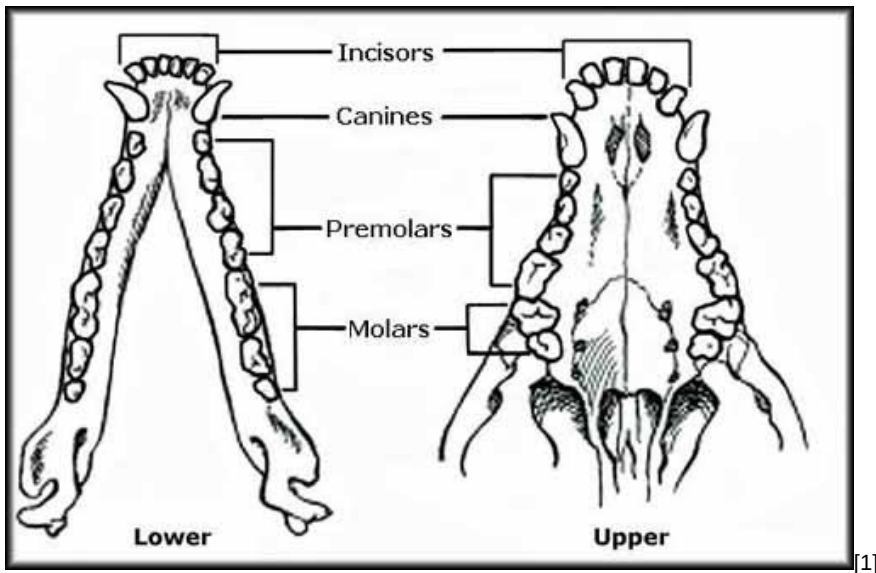

Common fractures are seen in the M1 tooth, causing a large area of weakness throughout the mandible. These fractures are relatively common and are identified in ~90% of incidents. [3,4,5]

Tape muzzle:

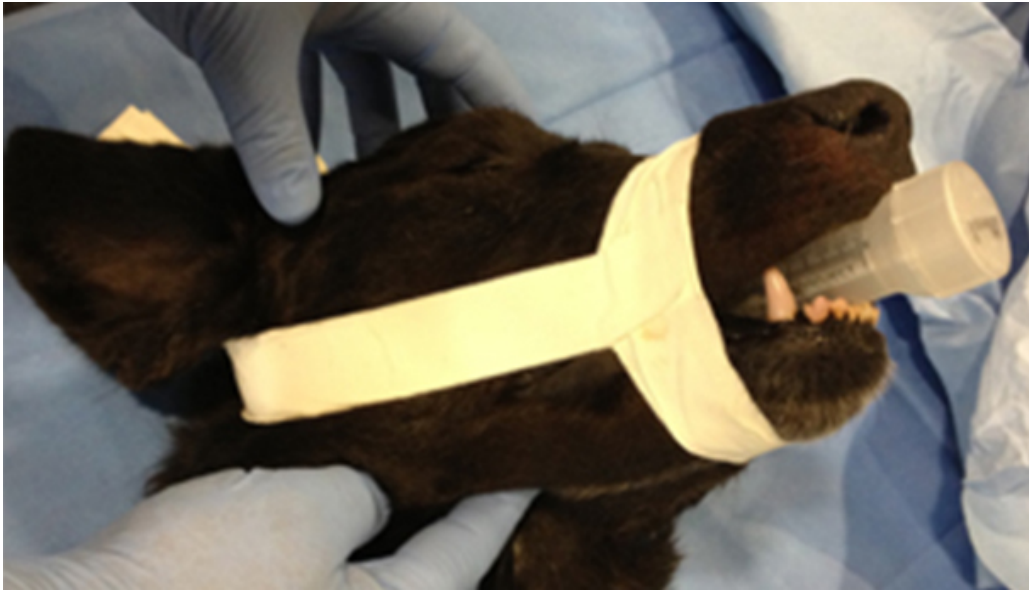

Nylon Muzzle:



Tape muzzles are inherently flawed as the effected area does not require complete rigidity to heal [6]

#### References:

- [1] [1] Lakeshore Road Animal Hospital, "Canine Teeth," 19, January, 2019. [Online blog]. Available: <https://www.oakvillevets.com/blog/789-canine-teeth>. [Accessed Sep. 10, 2020].
- [2] W. Harris, "Wolf mandible diagram." 08-May-2016
- [3] Lopes FM, Gioso MA et al. Oral fractures in dogs of brazil- a retrospective study. J Vet Dent. 2005;22(2):86-90.
- [4] Soukup J, Mulherin BM, Snyder CJ. Prevalence and nature of dentoalveolar injuries among patients with maxillofacial fractures. J Small Anim Pract. 2013;54(1):9-14.
- [5] Kitshoff AM, de Rooster H, Ferreira SM, Steenkamp G. A retrospective study of 109 dogs with mandibular fractures. Vet Comp Orthop Traumatol. 2013;26(1):1-5.
- [6] Manfra Marretta, S., Schrader, S.C., and Matthiesen, D.T. (1990). Problems associated with the management and treatment of jaw fractures. Probl. Vet. Med. Surg. Dent. 2: 220

#### Conclusions/action items:

Report my findings to the team at our next meeting



## 9/16/2020 Tape Muzzles

MATTHEW WROBLEWSKI - Dec 09, 2020, 9:20 AM CST

**Title:** Tape muzzle research

**Date:** 9/16/2020

**Content by:** Matt Wroblewski

**Present:** N/A

**Goals:** Gather info on current treatment of mandibular fractures

**Content:**

A tape muzzle that maintains canine interlock but also allows the mouth to open far enough to let the tongue protrude can stabilize the jaws while still allowing the patient to drink and eat a gruel diet. [1]

Treatment besides muzzles can be used but are highly invasive and require immobilization and large metal plates to be used. Typically only used when the mandible is highly unstable and cannot be treated by external immobilization alone. [2]

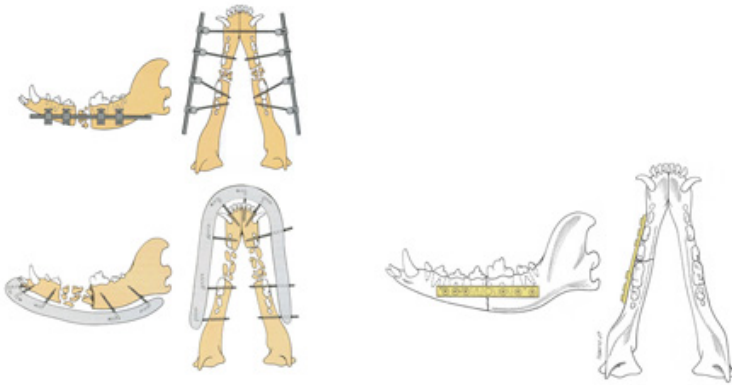

There are actually several other treatment methods:

Maxillomandibular fixation (tape muzzle)

- Circumferential wiring
- Interdental wiring and intraoral splinting.
- Intraosseus wiring.
- External skeletal fixators (ESFs)
- Miniplates (titanium)

But the tape muzzle remains the cheapest and least invasive of the treatments, furthering our project purpose to better this already very useful albeit crude tactic and create a more normalized/standardized form of treatment beyond tape muzzles which have downfalls of their own. [3]

[1] A. Somrak, "Tape Muzzle Helps Maxillofacial Injuries," *Practitioner Updates*, 15, September, 2015. [Online Journal]. Available: <https://vetmed.illinois.edu/tape-muzzle-helps-maxillofacial-injuries/>.

[2] ACVS, "Mandibular Fractures," *Small Animal Topics*, 2020. [Online Journal]. Available: [https://www.acvs.org/small-animal/mandibular-fractures#:~:text=Multiple%20methods%20of%20treating%20mandibular,surgical%20treatment%20\(Figure%204\)](https://www.acvs.org/small-animal/mandibular-fractures#:~:text=Multiple%20methods%20of%20treating%20mandibular,surgical%20treatment%20(Figure%204).).

[3] B. Higgins, *Fractures of the Mandible*, World Small Animal Veterinary Association World Congress Proceedings, 2013, Christchurch, New Zealand. <https://www.vin.com/apputil/content/defaultadv1.aspx?id=5709940&pid=11372&print=1>

**Conclusions/action items:**

Continue to increase my understanding of the task at hand and report what I have found to the team





## 9/10/2020 Bridge Mechanics

---

MATTHEW WROBLEWSKI - Dec 09, 2020, 9:35 AM CST

**Title:** Bridge Mechanics

**Date:** 9/10/2020

**Content by:** Matthew Wroblewski

**Present:** N/A

**Goals:** Better my understanding of Cantilever and Suspension bridge mechanics

**Content:**

Suspension bridges (i.e. Golden Gate) function by suspending the deck below suspension cables on vertical suspenders [1]

Cantilever bridges (i.e. Forth Bridge) function by using cantilevers (structures anchored at one end and suspended horizontally into space) [2]

In dentistry - Cantilever bridges are false teeth anchored by a crown on a real tooth, suspending the rest of the false teeth in a gap horizontally through the mouth. [3]

**References:**

[1] Weiwei Lin, Teruhiko Yoda, Bridge Engineering, 2017.

[2] "Cantilever Bridge Facts, Design, and History," History of Bridges, 2020 [Online serial]. Available: <http://www.historyofbridges.com/facts-about-bridges/cantilever-bridge/>

[3] S. Frothingham, "Dental Bridge," Healthline, 13 June, 2018 [Online serial]. Available: <https://www.healthline.com/health/dental-bridge#:~:text=Although%20similar%20to%20a%20traditional,to%20the%20missing%20tooth%20gap.>

**Conclusions/action items:**

Continue research, specializing what I now know about these bridge types to further understand possible construction ideas.



## 9/24/2020 3D Model Geometries

MATTHEW WROBLEWSKI - Dec 09, 2020, 9:41 AM CST

**Title:** 3D Model Geometries

**Date:** 9/24/2020

**Content by:** Matthew Wroblewski

**Present:** N/A

**Goals:** Learn more about meshing and FEA on solidworks

**Content:**

Solidworks has multiple mesh types and adaptive meshing

- Solid, Shell, Beam Elements
  - Solid Elements used for meshing, need to use for model
  - Draft Quality, high quality meshing.
    - Draft quality has 4 nodes, linear sides
    - High quality 10 nodes, 2nd order sides
      - allows much more closely matching to geometry
      - draft quality is good for "rough testing" since it is quicker and shows general idea
- Mesh Types
  - Standard, Curvature Based, blended curvature based
    - Std - specify global element size, +- tolerance
    - Crv - Upper and lower limit to elements, define # elements around a hole, lets define a growth ratio (how fast transitions small to large elements)
    - Blended - Same as curvature, different algorithm, use when other 2 don't work
- Adaptive Meshing
  - Mesh Independent Solution
    - Increase mesh density in an area to converge values taken to find true stress value
    - Adaptive meshing does this for you
  - H Adaptive
    - Changes mesh size and density based on where it thinks the stresses are
    - Target accuracy slider - defaults to 2% error
    - Mesh coarsening - makes faster, makes low stress areas larger geometries
    - Add mesh controls as a starting point for the solver to ensure more accuracy
    - Convergence charts
      - displays message when converged and met criteria, no message, did not meet
  - P-adaptive
    - P elements are all high quality elements (polynomial)
    - up to 5th order edges
    - can tell the study to focus on displacement, energy, or stress
    - P-adaptive does not add to mesh, changes polynomial order
    - Jacobian Ratio
      - Measure of curvature or distortion of a higher order element
      - Jacobian < 40 acceptable (<20 good)
      - Negative = high distortion
  - Mesh Quality plot
    - create very coarse mesh and then check if appropriate
      - Mesh, aspect ratio, jacobian
        - jacobian plot, check distortion
        - aspect ratio, ratio length to width elements,
  - Stress plot
    - nodal values
    - element values, colors entire element according to value
      - Allows to tell if at a mesh independent solution by checking for a good gradient between the geometries
  - Energy Norm Plot (is a stress plot)
    - Allows to run to reduce error in points of interest

[1] Cadimensions Inc., "Lunch & Learn - Adaptive Meshing - Make sure your FEA results are correct," Youtube, 28 February, 2017. [Video file]. Available: <https://www.youtube.com/watch?v=kasvCYVAPFE>. [Accessed: September 24, 2020].

**Conclusions/action items:**

Continue to increase my understanding of Solidworks/FEA.



## 9/30/2020 Solidworks FEA

---

MATTHEW WROBLEWSKI - Dec 09, 2020, 9:41 AM CST

**Title:** Solidworks FEA

**Date:** 9/30/2020

**Content by:** Matthew Wroblewski

**Present:** n/a

**Goals:** learn more about solidworks FEA

**Content:**

- Simulation -> new study -> static analysis
- Utilize fixturing to create fixed hinges on the part
- Add in forces wanting to test and where you want to apply them, direction
  - Be careful hitting enter when changing a value, might change it
  - Specific total or per item force
- Mesh can create automatic mesh on solidworks
  - Use better mesh for our project than offered normally
- Fine/coarse changes size of triangles
- Run when fully constrained, forces applied, mesh applied
  - Check for no large displacement after run
  - Inspect deformities, hit undo, is typically hyperbolized by solidworks to show location
- Safety factor plot can be created
  - Von Mises stress
  - Chart options, minimum, maximum
- Less fine mesh for larger parts unless the computer is a tank
- Standard mesh all triangles same size, curvature based mesh increases number near high concentration area

[1] Vijay Kumar Pingali., "Introduction to Solidworks Finite Element Analysis," Youtube, 20 February, 2017. [Video file]. Available: [https://www.youtube.com/watch?v=IG\\_oSSo9vak](https://www.youtube.com/watch?v=IG_oSSo9vak). [Accessed" September 30, 2020].

**Conclusions/action items:**

Continue to learn more finite element analysis and report findings to the team at our next meeting



# 10/30/2020 Idealized Calculations

MATTHEW WROBLEWSKI - Dec 08, 2020, 3:34 PM CST

**Title:** Idealized Calculations

**Date:** 10/30/2020

**Content by:** Matthew Wroblewski

**Present:** N/A

**Goals:** Look over the calculations done on the jaw idealized as a beam by my team and make any comments if necessary

**Content:**

*Cut @ where muscle for pulis; no other muscles in beam*

$F_{corn} = 1091 N$   
 $F_m = 571 N$   
 $F_{canine} = 518 N$

$l_{corn} = 30 cm$   
 $l_m = 425 cm$   
 $l_u = 550 cm$   
 $l_u = 675 cm$   
 $l_{canine} = 8.75 cm$   
 $l_{cut} = 9.0 cm$   
 $l_A = 325 cm$

Cross-section ~ 100% area @  $A = 1.75 cm^2$

Without Support

$\sum F_y = 0 \quad R_{mas} = F_{corn} + 3 \cdot F_m + F_{canine}$   
 $R_{mas} = 3315.9 N$

$M_{mas} = F_{corn} \cdot l_{corn} + F_m \cdot l_m + F_m \cdot l_u + F_m \cdot l_u + F_{canine} \cdot l_{canine}$   
 $M_{mas} = 171.73 Nm$

Mend of jaw = 0

Support type	Shear @ A (N)	Moment @ A (Nm)	Stress @ A (MPa)
No support	2224.8	6.669	74.66
Tape	566.85	45.98	51.46

Full	106.3	5.785	6.48
------	-------	-------	------

- Since the forces experienced by the jaw are very unlikely to cause bending, and with the elastic modulus of the bone not being very ductile would allow us to not only idealize the mandible as a beam from the geometry of it, but also allows us to make simple equilibrium calculations to determine the forces in play. Looking over the calculations, everything seems to check out
- LATER NOTE 12/1/2020 - after looking over our finite element analysis, the results show not perfect but quite similar results to that seen in our calculations, especially with no support and full support. I believe the difference between the tape muzzle here and in our FEA could come from the way we did not calculate direct shear force at the location of the fracture, or have a way to calculate a fracture in that would lead to the hinging movement that could cause more damage as mentioned by the client.

**Conclusions/action items:**

- Everything seems to check out, report back to team with no concerns



## 10/21/2020 3D Printing filaments

MATTHEW WROBLEWSKI - Dec 09, 2020, 8:53 AM CST

**Title:** 3D Printing Filaments

**Date:** 10/21/2020

**Content by:** Matthew Wroblewski

**Present:** N/A

**Goals:** Research 3D printing materials for use as battens

**Content:**

Properties

Ultimaker Nylon material has the following properties:

- Excellent impact strength (Izod tested to 34.4 kJ/m<sup>2</sup>)
- Good ductility (210% elongation at break)
- Melting temperature (from 185 °C)

Ultimaker PP (polypropylene) is a durable, chemical resistant material. It has exceptional fatigue resistance, high levels of toughness, and a low-friction co-efficient. From electrical components to living hinges, PP is the go-to material for prototyping and end-use parts.

Some of the key mechanical properties of Ultimaker PLA include:

- Excellent flexural strength (103 MPa)
- Good impact strength (Izod tested to 5.1 kJ/m<sup>2</sup>)
- High hardness (83 Shore D)
- Low melting temperature (from 145 °C)

- Information gathered from the official Ultimaker website.
- [1] *Ultimater Support*, Ultimaker, 2020.

After looking at the MakerSpace's array of 3D printers I thought that the material types from the Ultimaker would suit us better than the resin types from the Form printers and so i researched avaiable materials from Ultimaker accordingly. Prolpropylene and Nylon seem to be promising choices for our use as battens, I also inspected PLA but I am cautious about this material being too hard.

**Conclusions/action items:**

Report findings to the team.



## 10/19/2020 Canvas/Mesh Materials

MATTHEW WROBLEWSKI - Dec 09, 2020, 9:03 AM CST

**Title:** Canvas/Mesh Materials

**Date:** 10/19/2020

**Content by:** Matthew Wroblewski

**Present:** N/A

**Goals:** Learn about mesh/canvas materials from the team and possibly conduct research of my own

**Content:**

From Alex's notes

Nylon:

- synthetic polymers --> can be melted into fibers and films
- strong and elastic fibers --> stronger than polyester
- tough and resistant to abrasions --> can stand up to dog rubbing against stuff
- easy to wash (good for owner and hygiene of dog)
- good thermal and chemical resistance
- not very moisture-wicking --> may be an issue with ventilation/breathability

Polyester

- aromatic - improve hardness, rigidity, and heat resistance
- aliphatic acids and diols - increase flexibility, lower melting/softening point, and improve process ability
- polyethylene terephthalate (PET)
  - semi-aromatic --> amorphous if rapidly cooled and solidified
  - semi-crystalline if cooled slowly
  - can be processed into fibers
  - high strength and toughness, abrasion and heat resistant
- PET fibers
  - crease and wear resistant
  - low moisture absorption --> could be an issue in breathability
- Polytrimethylene terephthalate (PTT) used in textiles
  - good durability and stain resistance

Cotton

- Good at absorbing water and releasing it --> better breathability rating
- easy to clean and can handle high water temps --> can sterilize muzzle with boiling water to prevent buildup of bacteria
  - good for dog owner
- wrinkle and shrinkage prone --> can reduce effect by blending with other materials (maybe a blend with nylon or polyester?)
- durable and strong
- resists abrasion and pilling
- may weaken from extended exposure to sun
  - might be relevant for dogs with a lot of outdoor exposure (high energy, active dogs)
- density - 1.5-1.54 g/cm<sup>3</sup>

**Conclusions/action items:**

After looking over the findings that have already been conducted by Alex, I see no need to continue research into the topic beyond familiarizing myself with what she has found as this is a lot of good information with very promising candidates. I will report this conclusion to the team.



## 11/7/2020 Review of Peer Feedback

MATTHEW WROBLEWSKI - Dec 08, 2020, 3:35 PM CST

**Title:** Matthew Wroblewski

**Date:** 11/7/2020

**Content by:** Matthew Wroblewski

**Present:** N/A, to be discussed with team

**Goals:** Review our Show and Tell Peer feedback from piazza and see if there is any information that we can apply to our project

**Content:**

It looks like you guys have done a lot so far! My dogs have had some big surgeries over the years and the recovery process is always a struggle so I think your project could really help. I don't have a ton of experience with FEA, but I think sometimes it is easier to run a simulation if the model is simplified. When creating a model in AutoCAD or Solidworks a lot of little details, like fillets and rounds, are added. These are not always necessary to have in the FEA simulation, so if you guys go back and make these changes, it could help. Here are a few links that might be useful:

<https://www.dfrsolutions.com/blog/fea-model-simplification>

<https://enterfea.com/before-you-run-analysis-fea-checklist/>

You guys may have already addressed this, but in the sketch of the design it looks like the mesh part is right next to the canine's teeth. Do you think the mesh could get caught on them and rip?

- The articles that were supplied offered more of the same information that we have been using
- While the mesh is close to the canine's teeth, we believe that the canine would not be able to open its mouth wide enough for this snagging to occur.

To start off I would like to say I think the visuals are an amazing way to show what you guys have been working on. It seems like you have really defined the problem and thought of possible ways to proceed moving forward from here.

Along with visuals, however, our group has been working with animations to show the problem and - therefore- draw more tangible conclusions to those problems if that is something you guys are interested in. We are currently using Blender. There are many helpful tools within blender once you get the hand of how to use it and manipulate the pieces. I would also like to say that using animation to show where the piece will fit and how it will operate has allowed our team to better explain this issue to our mentor and speak more specifically with our client about the priorities that he wants us to focus on.

Additionally, something that we found helpful was finding new ways to make the mechanical piece (almost a "mechanical team") as well as having people work on the software side of the project. We can give suggestions on how to do this further, but it helped streamline both initiatives greatly. In other words, having a team brainstorm possible new ways to make a muzzle as well as possible new ways to streamline the software building process.

Sorry, I could not give specific FEA tips but hopefully, these are a bit helpful! Good work and good luck with the rest of the semester!

- I have known about Blender from interests in my personal life but did not know that it could be used to build files and then convert them into a .stl file that we would be able to then use for FEA. However, to my understanding the primary function for Blender is more animation and artistically focused so I believe that a more mechanically oriented program would do the job
- The split team idea is a good idea and I will bring this up to the group

As a dog owner, I would like to thank you for your project as a way to make care for dogs more affordable. I did some research into FEA since I was unfamiliar with it. What was recommended if the model is too complex to run is that you should simplify the model to basic but applicable level or to split it into parts if possible. Another big point was to make sure that the forces being tested are accurate to real scenarios that the material would be under in terms of not only location, but also direction. These points can be found at this link:

<https://www.hitechfea.com/fea-knowledgebase/checklist-to-ensure-validity-of-your-finite-element-structural-analysis.html#:~:text=Checklist%20to%20Verify%20Structural%20Analysis&text=Has%20the%20dimensions%20of%20FEA,enough%20to%20generate%20accurate%20results%3F> and many other sites regarding FEA and they are recurring themes I found.

One test that may want to be added, if it isn't already, is the possibility for the material to be shifted over the dogs head and forced off. The idea of dogs not cooperating with the device was mentioned above, and I can also verify that my dogs, like many others, spend time finding every way to take off their dog cone (Or other devices that bound their head).

In terms of the nylon and mesh being used as the materials for the device, it is recommended to verify that they maintain the same structural integrity when covered in water or other fluids. It is also important that they dry rather quickly so it doesn't irritate the dog's skin from excessive water retention.

Overall, this project is headed in an amazing direction and the modeling that has been done is extraordinary. I truly hope that your project makes great progress and can be implemented in a wider setting!

- Link provided is a good source for a checklist for when we continue our FEA attempts
- We do not really have a useful way to test this beyond looking at our design and judging if it is structurally sound at this point

To begin, I think this is a really interesting project. I think it's important to consider situations like what this project hopes to combat: further complications that happen during recovery from surgery. As a dog owner myself, I find that sometimes dogs really don't want to cooperate on simple things. I couldn't imagine trying to get a dog to behave following surgery when all they want to do is just be a dog.

Along with what was said in one of the previous comments, I don't have a ton of experience with FEA as it relates to Solidworks and AutoCAD models, but I would still endorse what is being said above. I think that finding ways to simplify the model will allow you to execute your necessary FEA. Once you produce a model that can get through FEA, then you can evaluate if the feedback from that testing is sufficient enough to move forward, or if you need to add back some complexity from the original detailed model and redo the FEA to get more information.

I agree with the resources that were posted above as well, and I believe there's already a lot of good information in this thread that may prove to be helpful. There's also a guide for simplifying CAD models for FEA put out by Midas NFX, and one of the contributors for that guide, Cyprien Rusu, posts some interesting content on YouTube related to this issue. I'd recommend checking out that channel to see if any of the tutorials may be helpful. It's a different CAD program, but the content may still be useful. One video in particular showed him taking slices of his model to minimize the effect of removing the complex elements. That particular video can be found here: <https://www.youtube.com/watch?v=qj16YChO8Fg>. Depending on where different forces are acting related to your FEA and what the area is that those forces act over, maybe you can get away with analyzing a simplified slice of your model and still preserve the majority of the overall complexity.

Best of luck! I'll be interested to hear how you overcome this FEA obstacle.

- The taking chunks out of the model is a good idea, but I am hesitant about its effects on the force distributions, also we would have to license this program and learn all of its features in order to utilize the suggested video, but the input has been noted and we may want to look into this further at a later date.

First off, I think you guys have made significant progress on an issue that could make the lives of pet lovers everywhere cheaper and easier so congrats! Upon first glance of your project my immediate concerns for the muzzle was concerned motion restriction. I have dealt with multiple bone fractures (in both myself and my pets!) and the easiest/cheapest way to avoid surgery is complete immobilization. Obviously for the jaw, this is not possible as the animal has to eat. My concerns lie with the ability of your design to limit jaw movement enough to heal while also allowing enough jaw movement for the animal to eat comfortably. I was able to find a what I found to be a functional answer to this problem at these sites:

<https://www.acvs.org/small-animal/mandibular-fractures>

<https://www.bostonherald.com/2017/12/17/dog-has-trouble-eating-can-barely-open-mouth/>

I found that post treatment for a mandible fracture requires the switching from a dry food to wet food diet for most dogs to limit as much stress on the teeth/jaw as possible. Then, I was able to see that most dogs can still eat and drink (wet food in particular) even if their mouths can only open less than 2 in. I would recommend further research into this, to try and limit movement as much as possible. The American College of Veterinary Surgeons specifically stated that the animal should definitely not be able to open their mouth enough to play or chew as this could have serious repercussions on the fracture healing process.

For the FEA, I do not have a lot of experience with them but from what I could find here:

<https://www.fusioneng.com/finite-element/stress-analysis/>

[https://www.fusioneng.com/finite-element/stress-analysis/?\\_vsrefdom=ppcgoogle&utm\\_source=google&utm\\_medium=cpc&utm\\_term=finite%20element%20stress%20analysis&utm\\_campaign=Fusion%20Engineering&gclid=EAlalQobChMlmcHF483u7AIVUdbACh1SBQgLEAAYIAAEgJvK\\_D\\_BwE](https://www.fusioneng.com/finite-element/stress-analysis/?_vsrefdom=ppcgoogle&utm_source=google&utm_medium=cpc&utm_term=finite%20element%20stress%20analysis&utm_campaign=Fusion%20Engineering&gclid=EAlalQobChMlmcHF483u7AIVUdbACh1SBQgLEAAYIAAEgJvK_D_BwE)

It is important to run the simulation on individual pieces. I cannot exactly tell on your shown design file if the muzzle is supposed to be one piece or multiple pieces, but that would be an important step in the FEA. From what I can gather, Fusion Engineering looks like a good comprehensive system to perform detailed, iterative analysis of a complex system if that's what you are searching for. Good work on the project so far, I think its very interesting and has the potential to help people and animals everywhere! Hope this helps some!

- We are confident in our current design to restrict the movement of the jaw, and have been provided medical documentation from the client on these matters
- More FEA information

Hello,

I have also worked on a VetMed project before and similarly I wanted to run FEA testing in Solidworks on both the stl of the jaw and of the implant we were working with. The reason why the simulation is failing is because of the high number of triangles in the design. The file that you have looks like it has already been cleaned up quite a bit. My team was able to reduce the triangles significantly when we worked on the project.

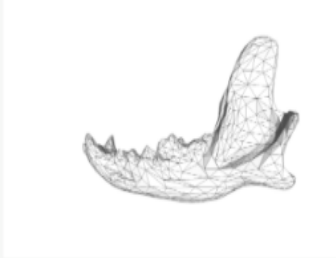

We worked on the project several semesters ago and when we ran the simulation with this model it would still fail, but I would try it with Solidworks 2020 to see if the updated Solidworks is capable of running the simulation. My team member used MeshMixer to reduce the triangles, but I had more success using MeshLab. MeshLab was very easy to use and I would recommend looking into whether it would be the better option. If the simplified model continues to fail, the FEA analysis doesn't require a model as detailed as the scan of the jaw. Our solution was to create a new model in Solidworks from the dimensions of the jaw scan. For example, this was a representation of the jaw we used in our FEA analysis.



While it isn't an ideal solution, I would recommend putting in time to recreate a relatively accurate model if you cannot sufficiently reduce the number of triangles in the stl files provided.

Here's another example. Meshlab was used to reduce the triangles for an implant.

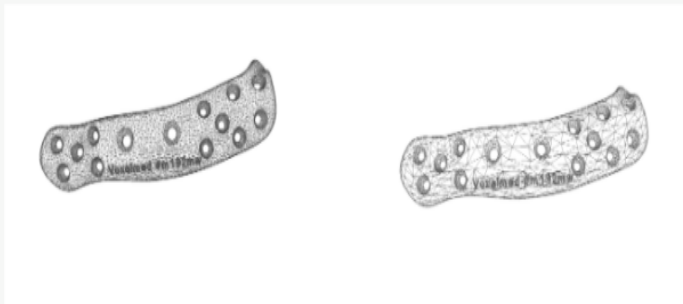

After using MeshLab to reduce the triangles, the simulation was very close to running but continued to fail. This was the simplified model we created.



This method worked well for us. We were able to do FEA testing. In fact, we made several models that ranged from an incredibly simplified model to the most complex model we were capable of. Our findings found that the FEA analysis did not vary much between these different levels of complexities. As long as sharp angles are avoided and the general shape and dimensions are maintained, the FEA analysis should be relatively accurate.

- Use of Meshlab is noted and we will likely try to implement similar ideas as seen here.

#### Conclusions/action items:

Overall a lot of useful links were supplied by our peers, I will meet with the team to discuss what I have learned







## 9/22/20 Preliminary Designs

MATTHEW WROBLEWSKI - Dec 09, 2020, 9:42 AM CST

**Title:** Preliminary Designs

**Date:** 9/22/2020

**Content by:** Matthew Wroblewski

**Present:** N/A

**Goals:** Come up with 3 preliminary Designs

**Content:**

Design 1) Pretty standard muzzle, links bottom with battens to 2 separate top straps, one of which linking to the back of the head.

Design 2) Similar to first design, more curved to allow for battens and possibly more support

Design 3) Undercut piece of the jaw to remove force from the fracture area with over the top of the head straps between the eyes and the ears, may be a possible area for slip.

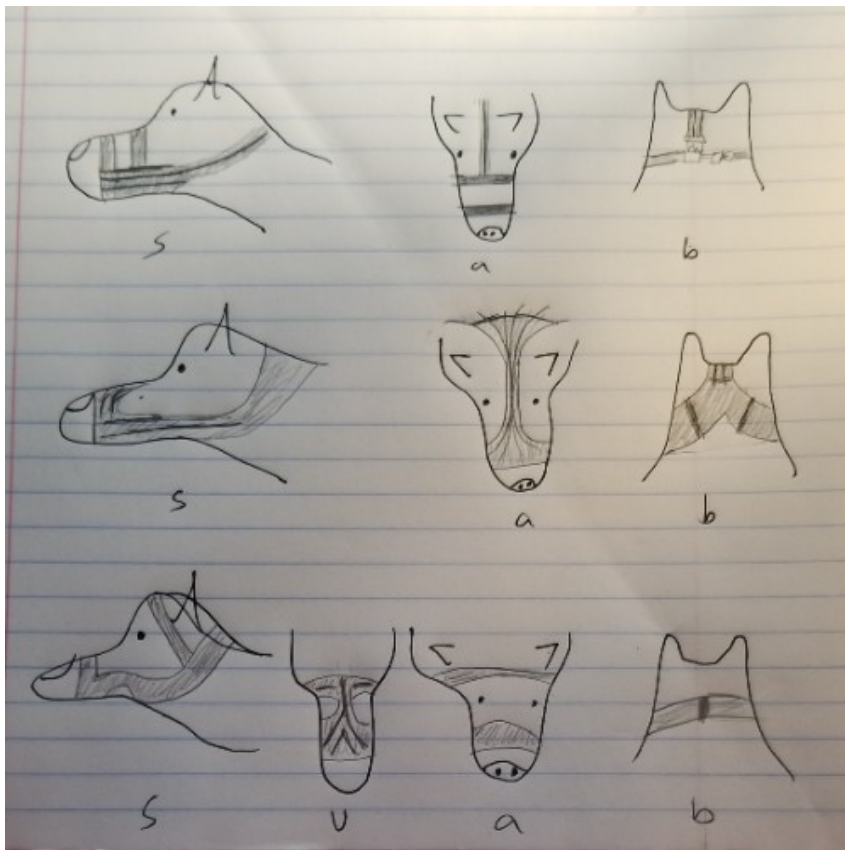

**Conclusions/action items:**

Bring these designs to the team and see if any of them are good enough to use moving forward for our design matrix



## 10/21/2020 3D Jaw Scan

---

MATTHEW WROBLEWSKI - Dec 07, 2020, 2:46 PM CST

**Title:** 3D Jaw Scan (Skull and no Skull)

**Date:** 10/21/2020

**Content by:** Matthew Wroblewski

**Present:** N/A

**Goals:** Examine the 3D Scans that the team was able to create from the skull given to us by the client and with help from the UW Makerspace

**Content:**

3D Scan of the skull with no jaw (left) and just the jaw (right)

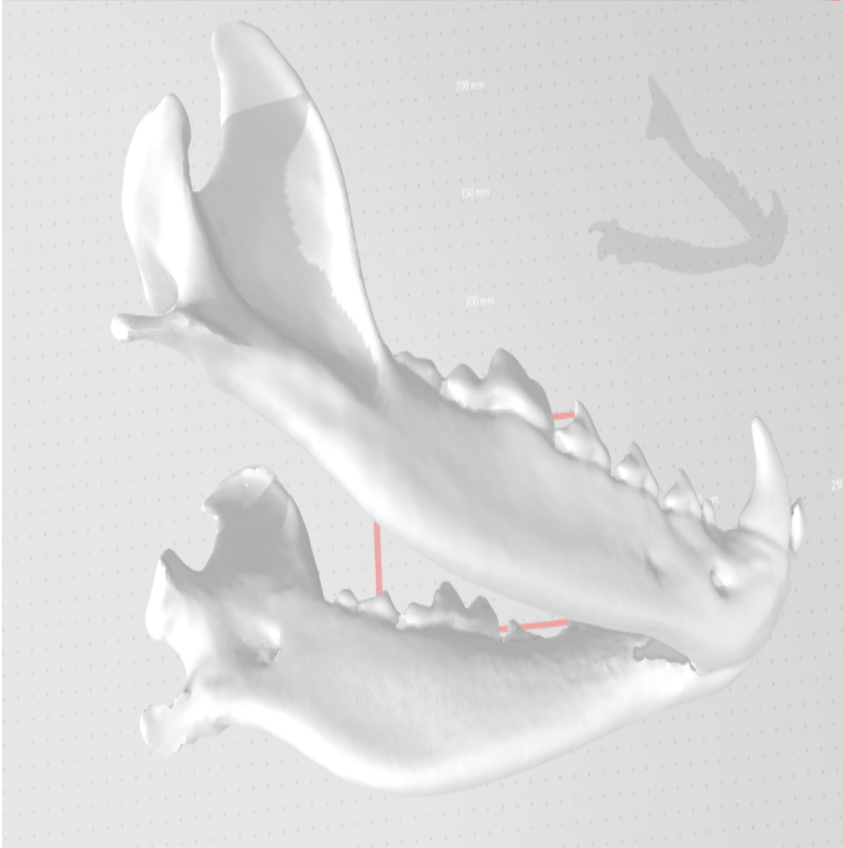
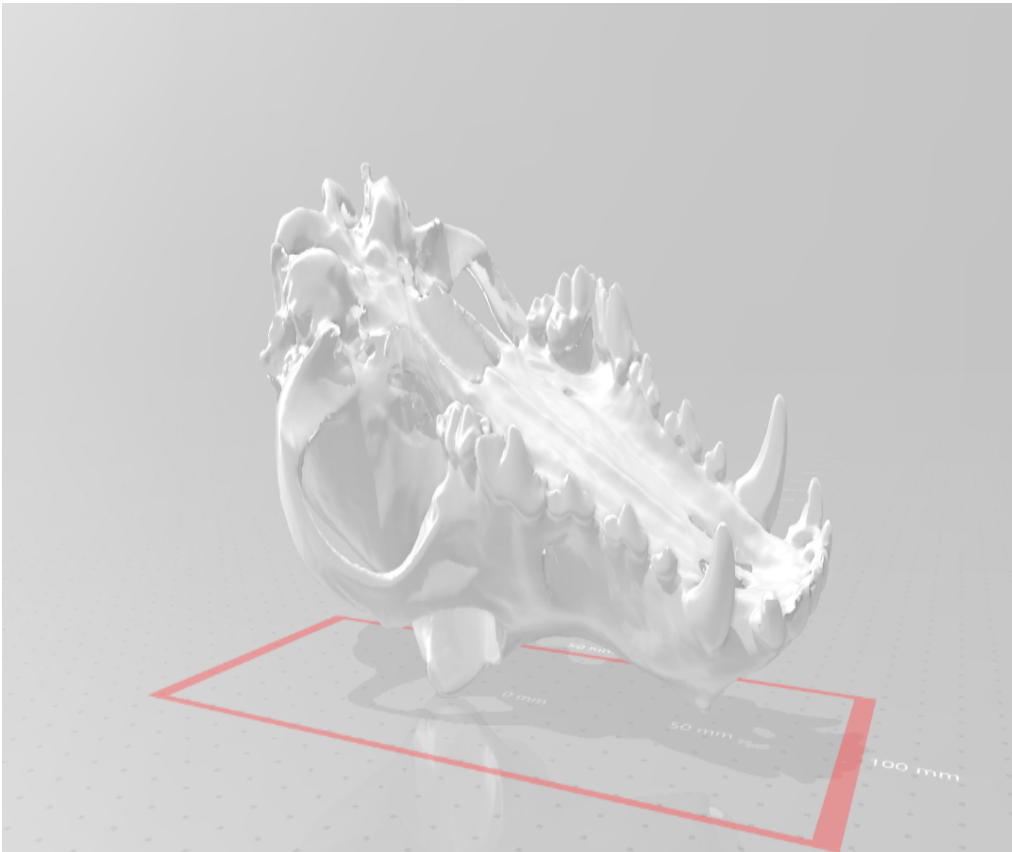

After placing both scans into Solidworks we discovered multiple things to figure out moving forward

1. The scans are only deemed as surfaces with no distinguishable mass or thickness to the layers seen in the pictures
2. The nature of the scan has created such a complex polygon configuration that the sheer number of facets is far too much for our computers or solid works to handle
3. There appears to be a hole in the jaw scan that we will have to figure out a way to patch

**Conclusions/action items:**

Overall the scans are an exciting step forward towards completion but are also proving to be a much more difficult endeavor than originally anticipated. Moving forward, will have to figure out ways to solve all 3 of the above listed issues if we hope to use these files for FEA.



## 10/24-10/29/2020 3D scan evidence of reduction attempts

MATTHEW WROBLEWSKI - Dec 07, 2020, 3:34 PM CST

**Title:** Attempts at Reduction and Repair for FEA of 3D Jaw Scan

**Date:** 10/24-10/29/2020

**Content by:** Matthew Wroblewski

**Present:** N/A

**Goals:** Reduce and Repair Jaw and complete an FEA

**Content:**

Autodesk AutoCAD

- Downloaded AutoCad after various failed attempts to open up the Jaw.igs file for manipulation and was successful in viewing the file, but still could not do anything. Autodesk abandoned as a viable method of manipulating the file

Meshmixer

- Downloaded Meshmixer, was able to open the file but was still unsure of how to edit the files at all, abandoned temporarily before coming back in a couple of days after learning more and working with the other software



- First time opening the .igs file
- Meshmixer highlights the errors found within the scan, most notably a sizeable hole on the back side of the front of the jaw.
- Proceeded to utilize the various tools in the Meshmixer app to reduce, repair, make solid, and convert the file type of the part and then move the file over to Solidworks to see what had changed and what seemed more or less promising
- Most promising file ended up looking like this:



- However this file was still unable to be fully recognized as a solid within Solidworks in order for it to be properly simulated, and also likely still would struggle due to the very large facet count on the piece

#### Autodesk Fusion 360

- Next attempted to download and utilize Autodesk Fusion 360
- This program seemed the most versatile and easy to operate so far, and lead to the most promising results we had seen at this point

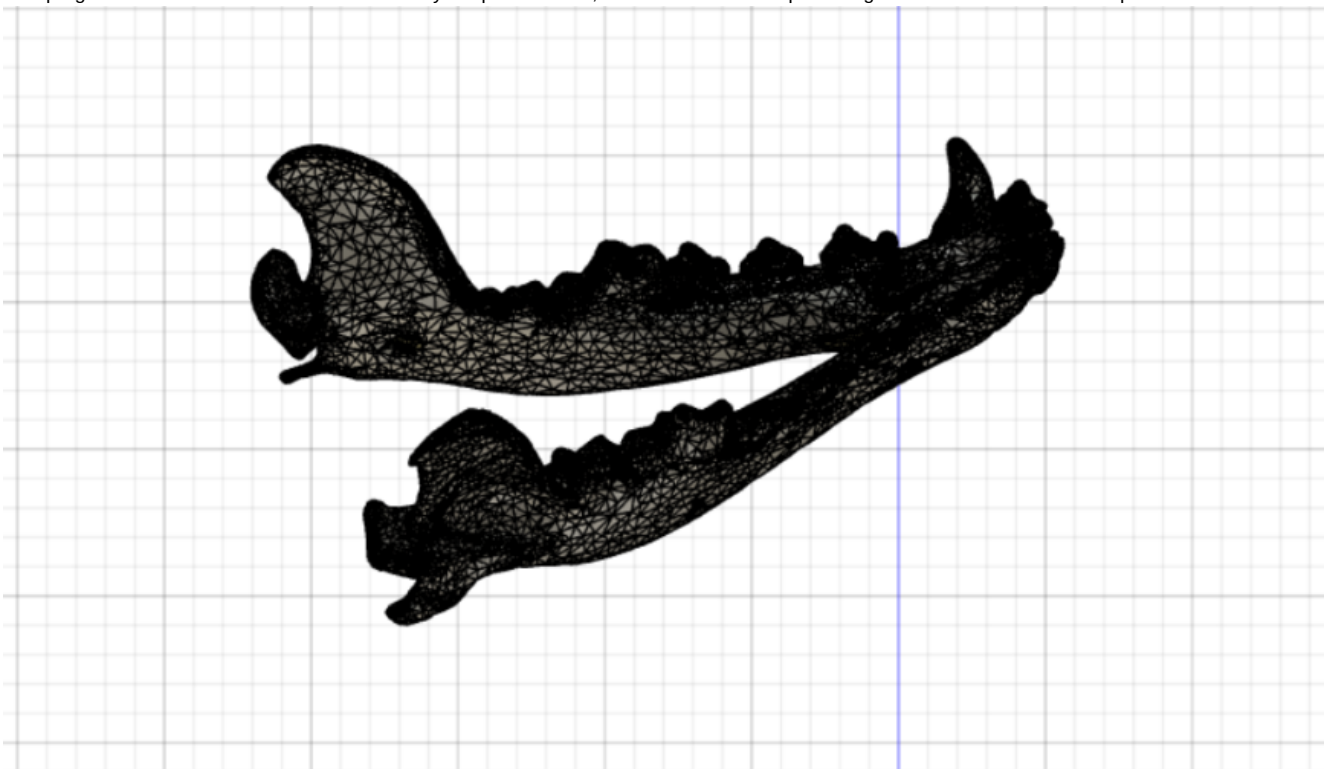

- First successful attempt at reducing the facet count and turning the part into a solid
- After moving to Solidworks, the facet count was still deemed to high and a less complex model was required still

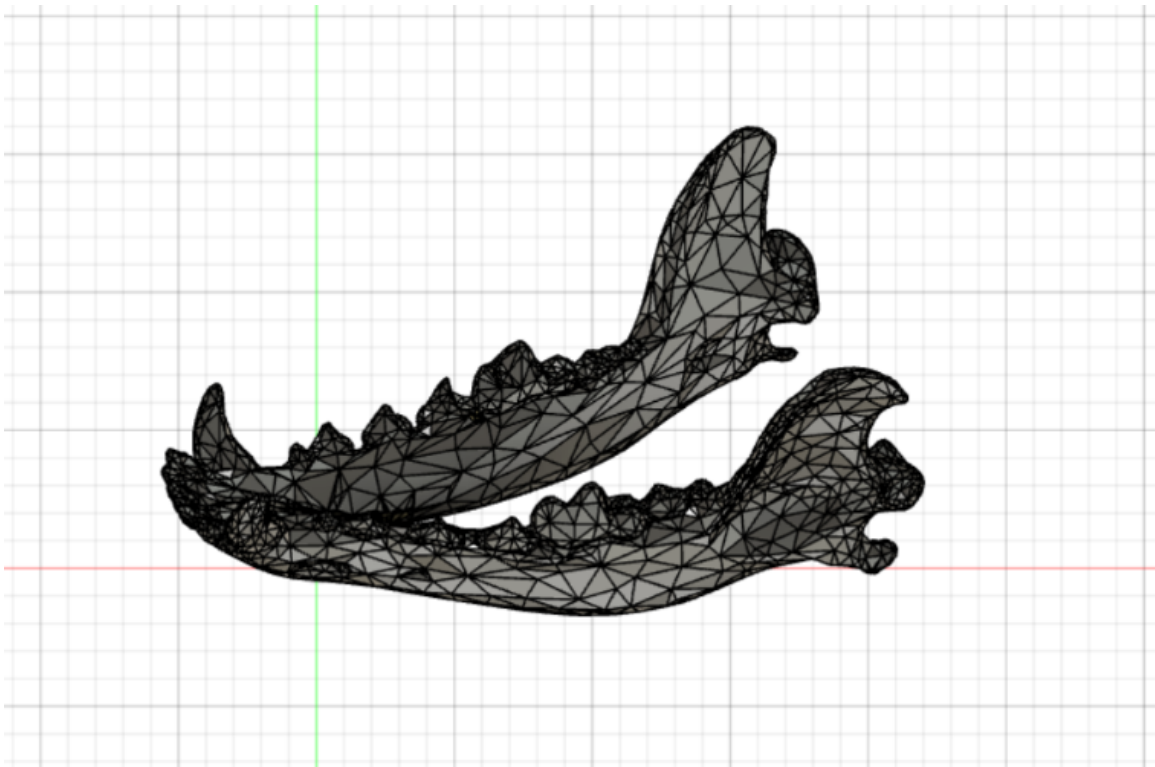

- 
- Next successful attempt at a further reduced jaw
- This attempt when moved to Solidworks proved to be just barely above the facet count for it to run proper simulations and further reduction was required still
- However: at this point there is a notable gathering of polygon dense regions of the jaw in locations where there should not be, further discovered to come as a result of the holes in the 3D scan

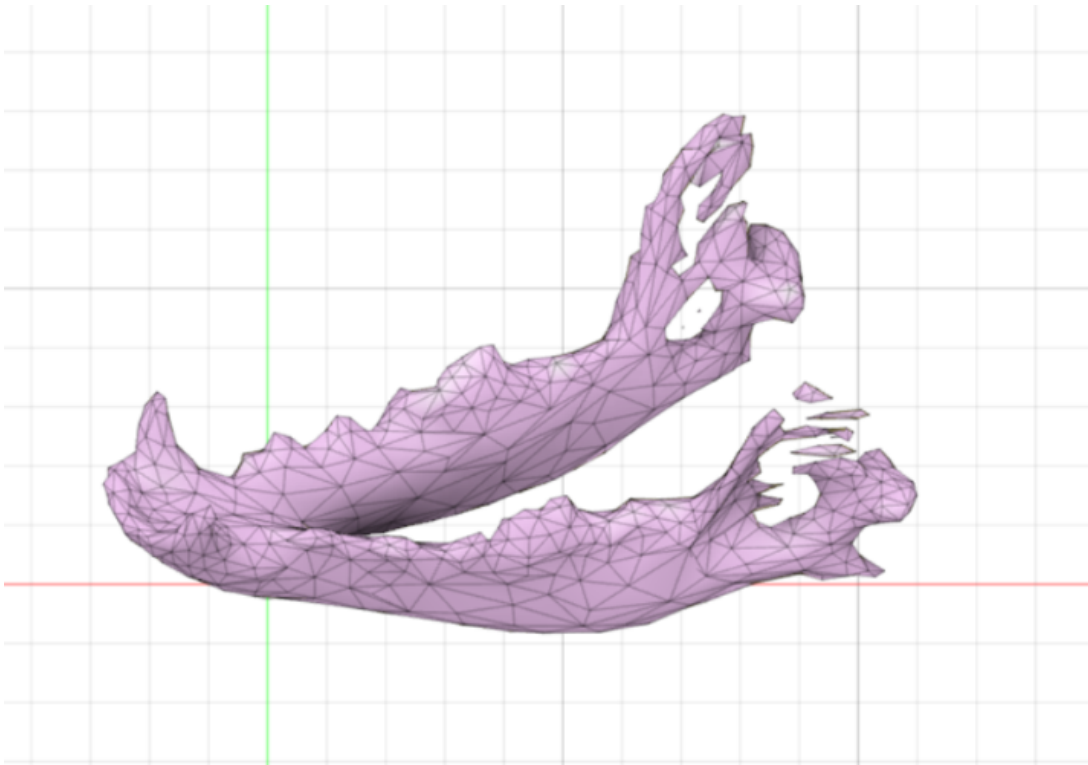

- 
- After further reducing the jaw, attempts to preserve the shape in order to maintain the integrity of the simulation resulted in this model, with large chunks missing from the file and floating pieces making it impossible to run simulations on

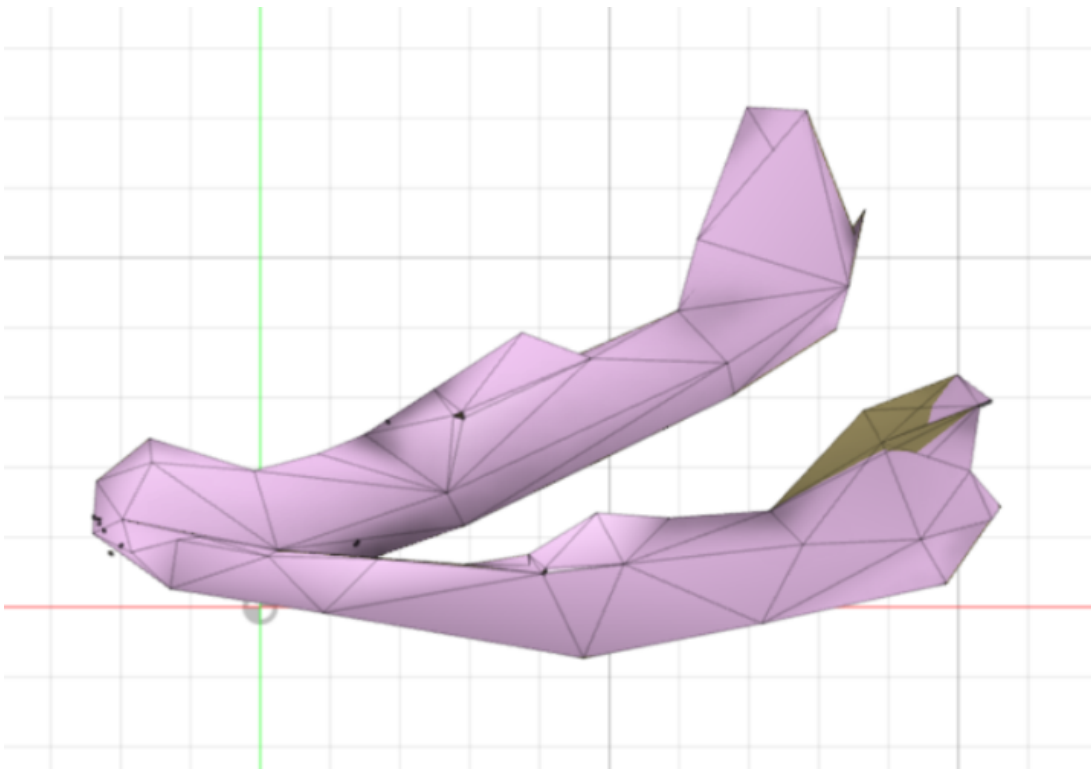

- Changing the settings to try and reduce the jaw file a substantial amount over several attempts altering polygon size, density, linear vs polynomial, etc. lead to this file which further highlighted the issues that were being presented by the large holes in the file.

#### Meshlab

- Downloaded and attempted to utilize Meshlab for its repairing and reducing tools that it is known for but did not see any results that were notable.

#### Continued work

- After using both Fusion 360 and Meshlab, I attempted to use both together to try and solve the problem
- Attempting to heal the files in Solidworks, Fusion360, and Meshmixer resulted in more issues than solutions
- Attempting to fill in the gaps in Fusion 360 and then reducing and converting the mesh to a body seemed fruitful only to still have miniscule holes that were unable to be ascertained by the naked eye and ruining the file.
- Filling in the gaps in Meshmixer and then bringing the file over to Fusion to be reduced yielded the same results
- Eventually, met with Kate and Arrington and through combination of knowledge were able to render one of our files into solidworks, but still needed a much more powerful computer in order to run a full simulation on the part, and attempts at using the same method to reduce the jaw further and run simulation would for unknown reasons fail

#### Conclusions/action items:

- Continue to try and run FEA on one of the files that the team currently has
- Look into creating a Solidworks model from scratch to run idealized FEA on





## 11/24/2020 Rough model

---

MATTHEW WROBLEWSKI - Dec 09, 2020, 9:50 AM CST

**Title:** Rough Model

**Date:** 10/24/2020

**Content by:** Matthew Wroblewski

**Present:** N/A

**Goals:** Create a rough model for use of FEA as an idealized model

**Content:**

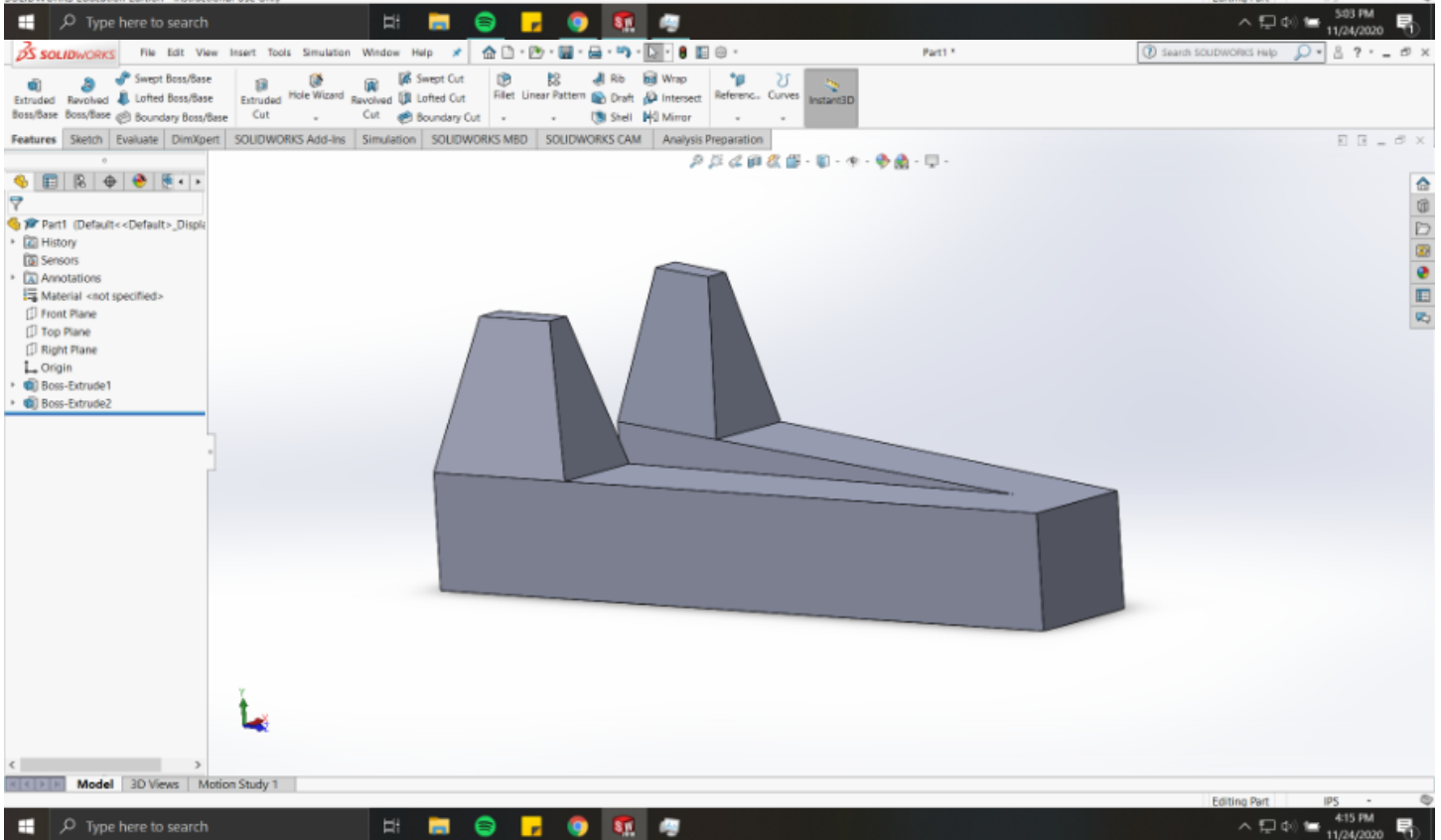
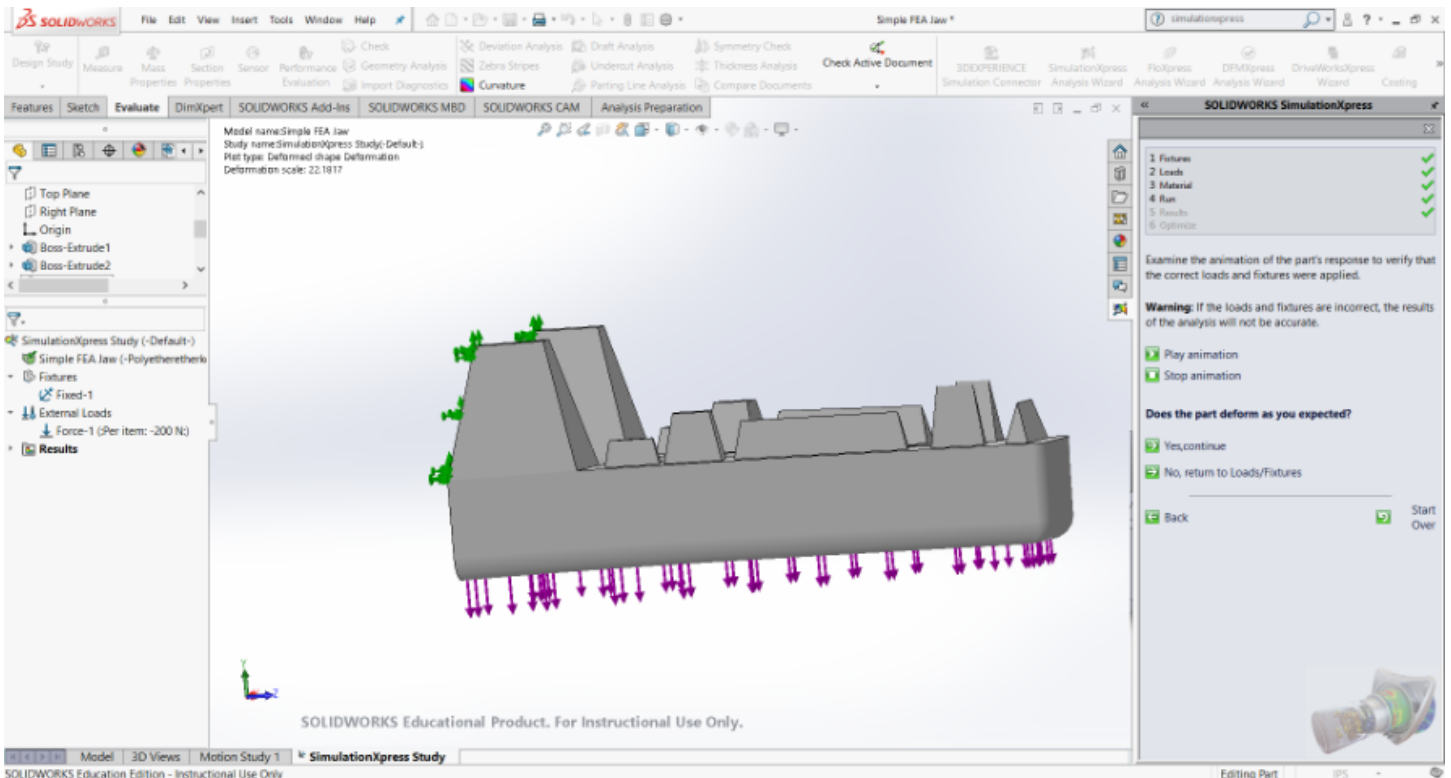

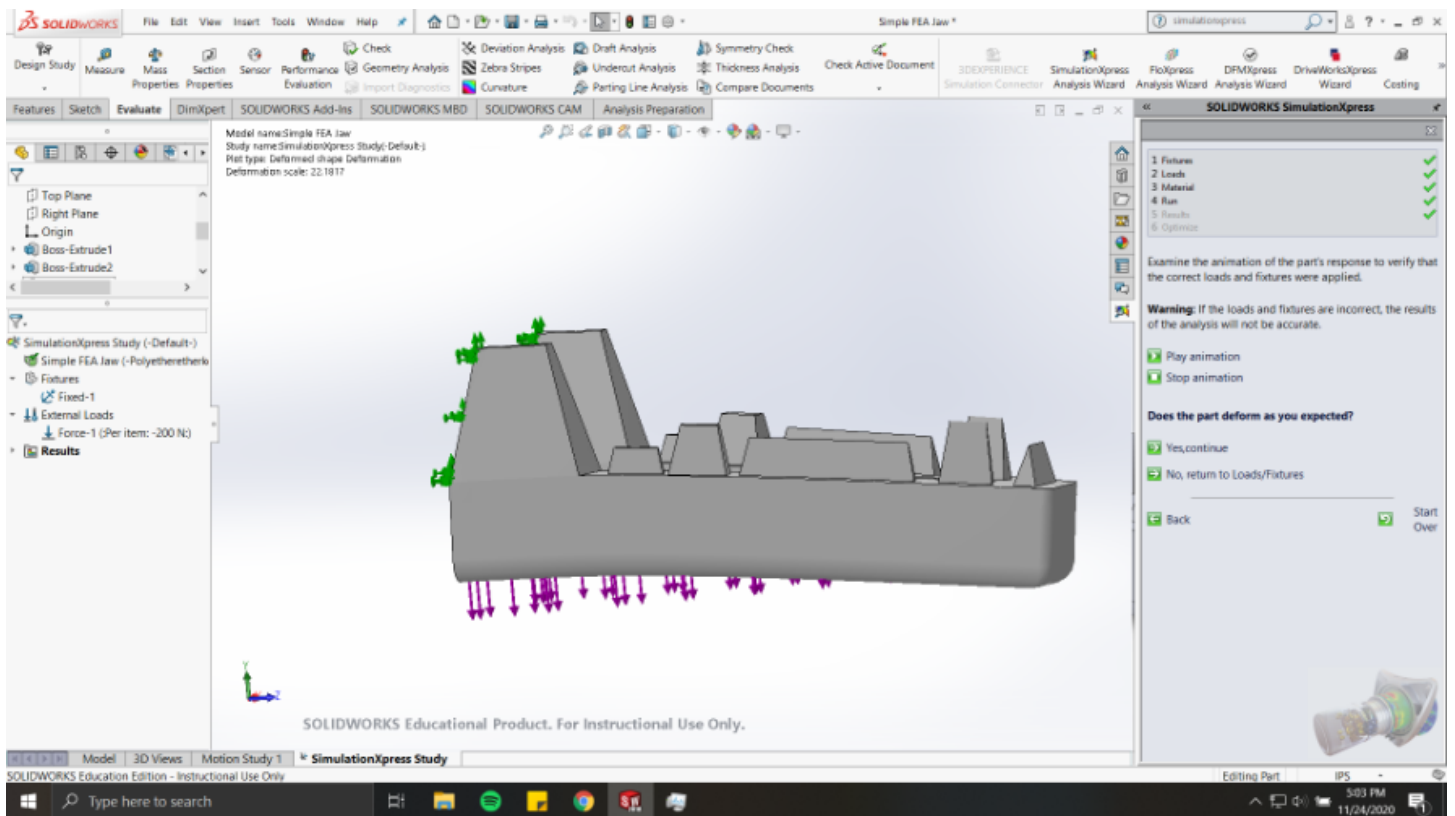

Conducted a FEA on a rough model that I made in SolidWorks. I was able to anchor the part and apply a force over the area of the bottom of the jaw and run the simulation appropriately, using a bone like plastic as a the material.

#### Conclusions/action items:

Learned a lot about construction of parts within Solidworks, through this I believe that the file involving the one side of the jaw but more accurate shape will yield valid results

Talk to the team about potential use of this file, however unlikely, and share what I have learned for the future of our FEA development



## 12/1/2020 FEA Overview

---

MATTHEW WROBLEWSKI - Dec 09, 2020, 9:48 AM CST

**Title:** FEA Overview

**Date:** 12/1/2020

**Content by:** Matthew Wroblewski

**Present:** N/A

**Goals:** Look over the FEA conducted by the team and make any comments

**Content:**

 feano\_support.PNG - FEA for simulation with no support

\*Picture from Kate, posted for reference

- The FEA conducted by the team works and provides the information needed to move forward with our project. My only concerns lie in the lack of variability within the fracture that could become a source of error in our testing. However, this would require a great deal more work and would not be viable to complete within this semester

**Conclusions/action items:**

- Report my approval to the team



MATTHEW WROBLEWSKI - Dec 08, 2020, 10:45 AM CST



thumbnail\_20201208\_104300.jpg(173 KB) - [download](#) Red Permit

MATTHEW WROBLEWSKI - Dec 08, 2020, 10:46 AM CST

COE Red Shop Permit

## 2020/9/8- Tape versus Nylon Muzzles

Sydney Appleton - Sep 08, 2020, 6:32 PM CDT

**Title:** Background Research on Types of Muzzles Used to Repair Mandible Fractures in Dogs

**Date:** 9/8/2020

**Content by:** Sydney Appleton

**Present:** Sydney Appleton

**Goals:** Gain more knowledge on background relevant to our project.

**Content:**

**Project Objective:** Create an alternative nylon muzzle to the preexisting tape muzzle currently being used in mandible fracture recovery.

**Project Description:** Canine mandibular fractures frequently occur in the M1 (seen in figure 3) due to an area of weakness in the mandible from the relatively large number of M1 present [1-3]. There are several oral repair techniques that can be done; however, many owners do not have the appropriate financial means for the surgeries [1-2]. Because of this, tape muzzles are utilized as an inexpensive alternative made with disposable bandaging tape. They are made easily by placing one layer of tape around the muzzle with the adhesive side out and then repeating this so the adhesive sides are touching. Using a similar method for the head strap, the tape is placed around the nose back behind the ears (figure 1). There must be a 0.5 to 1.0 cm gap in the incisors in order for canines to drink and eat soft food [3].



Figure 1

(Figure 1 - Tape Muzzle)

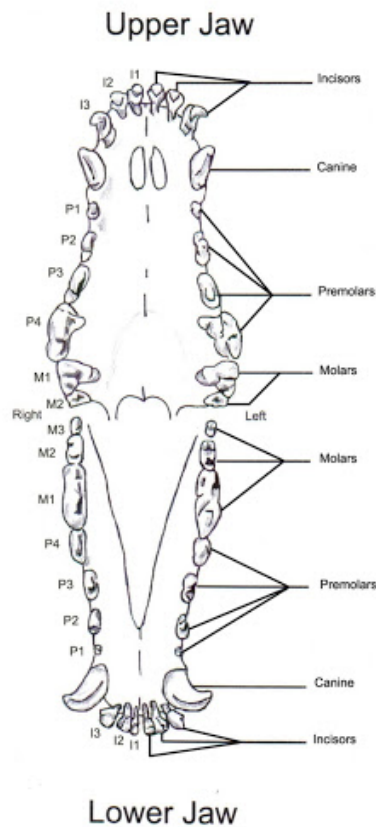

(Figure 3 - M1 [5])

In the current tape muzzle design, there are inherent flaws such as the rigid fixation of an area with rich blood supply and lack of heavy weight bearing. There is also a pivot point due to the lack of tape which can lead to a longer healing period and more pain [4].

A nylon or mesh muzzle is an affordable alternative that create more of a sling where the mandibles are cradled near the fracture. These are easily maneuvered with a buckle behind the head (figure 2).



Figure 2

(Figure 3 - Nylon Muzzle)

**References:**

- [1] Kitshoff AM, de Rooster H, Ferreira SM, Steenkamp G. A retrospective study of 109 dogs with mandibular fractures. *Vet Comp Orthop Traumatol.* 2013;26(1):1-5.
- [2] Umphlet R, Johnson A. Mandibular fractures in the dog, a retrospective study of 157 cases. *Vet Surg.* 1990; 19: 272-275.
- [3] Withrow, S.J. (1981). Taping of the mandible in treatment of mandibular fractures. *J. Am. Anim. Hosp. Assoc.* 17: 27.
- [4] Manfra Marretta, S., Schrader, S.C., and Matthiesen, D.T. (1990). Problems associated with the management and treatment of jaw fractures. *Probl. Vet. Med. Surg. Dent.* 2: 220.
- [5] "Full Dentition Chart." 09-August-2013

**Conclusions/Action Items:**

Since we already have a testable design, we need to figure out how to measure the stresses on the nylon muzzle. I will research ways to quantify these stresses and begin the work to minimize them.

## 2020/9/16 - Compressive Forces in Canines

Sydney Appleton - Dec 05, 2020, 10:53 AM CST

**Title:** Background Research on Compressive Forces in a Canine Mandible

**Date:** 9/16/2020

**Content by:** Sydney Appleton

**Present:** Sydney Appleton

**Goals:** Learn more about the amount of force a canine can exert through their mandibles.

**Content:**

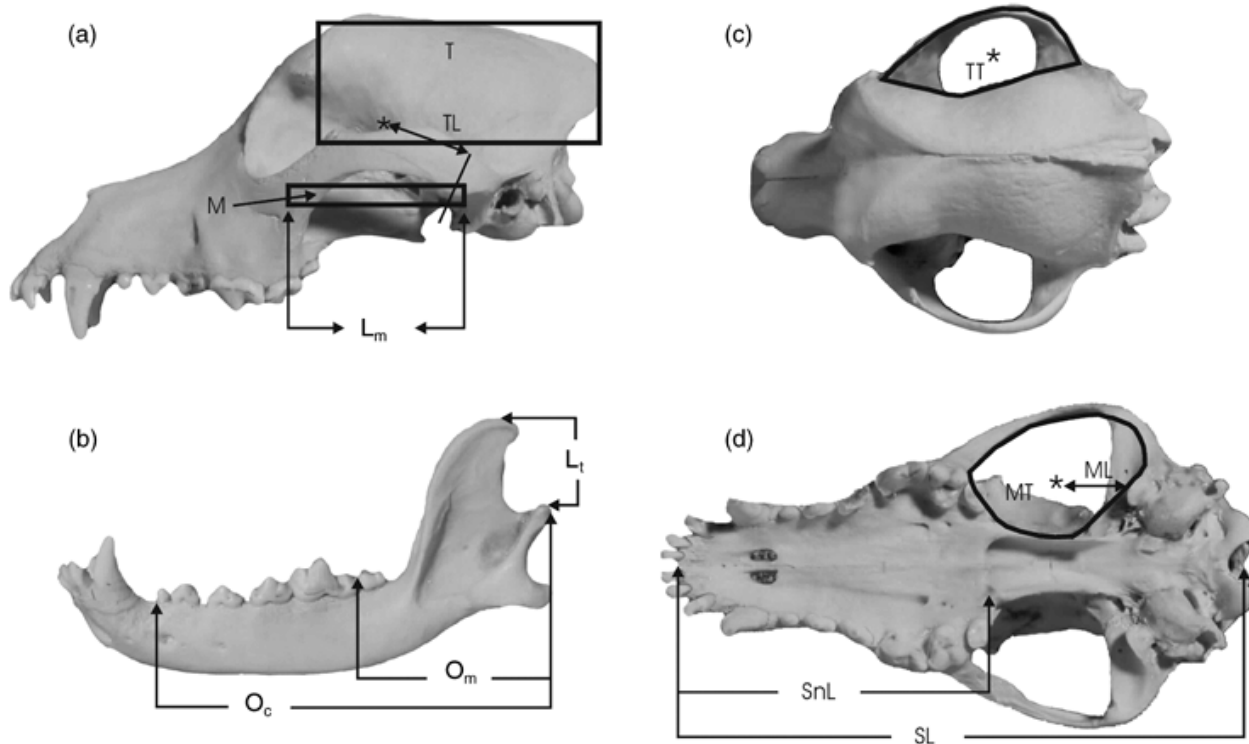

Figure 1 (lateral view of the skull (a), lateral view of the mandible (b), dorsocaudal view of the skull (c) and ventral view of the skull (d) - Measurements used to obtain force exerted) [1]

Using two locations, forces of biting were estimated for various breeds of dogs. The first location measured the Canine Bite Forces, and it was immediately behind the canine contacting the first premolars  $P^1$  and  $P_1$  while the second location was between  $P_4$  and  $M_1$  on the maxilla and between  $M_1$  and  $M_2$  on the mandible named the Molar Bite Force [1]. Skull size and shape was also taken into consideration. The bite force of canines increases with size with the maximum force reaching up to 5000 N [1].

### References:

[1] Ellis, J. L., Thomason, J., Kebreab, E., Zubair, K., & France, J. (2009). Cranial dimensions and forces of biting in the domestic dog. *Journal of anatomy*, 214(3), 362–373.

### Conclusions/action items:

With more research about how these forces are exerted and the extent to which they are, we will be able to design a muzzle that can withstand the compressive force of a canine mandible and minimizes the stress at the place of fracture.





## 2020/11/12 - Dog Bite Force Measurements

Sydney Appleton - Dec 05, 2020, 12:44 PM CST

### Title: Measurements of a Dog's Bite Force

**Date:** 11/12/2020

**Content by:** Sydney Appleton

**Present:** Sydney Appleton

**Goals:** Verify the amount of force a dog's bite can exhibit.

### Content:

This study measured the bite forces in dogs (and cats) generated by different teeth. Since the bite force comes from different areas, its necessary to record the estimations from the masticatory muscles, the mandibles and maxillae, the temporomandibular joints (TMJs), and the teeth. Our project is focused on the fracture of the M1, so we are concerned the most with the loads exhibited by the teeth. These were measured using in vitro bite forces by calculation of the force produced using mechanical equations representing the jaw adductor muscles and of the mandible and skull structure. Bite force can also be estimated in silico using finite element analysis (FEA) of the computed model of the anatomical structures. [1]

The table below summarizes the results of various measurement methods used in dogs [1]. This information indicates that FEA may be the best way to carry forward with our simulations and analysis of the nylon muzzle.

**Table 1**

Studies on the bite force measurement/estimation in dogs and cats.

Animal	Measured/estimated location	Bite force (Newton, N)	Measurement/estimation method
Dog	Not specified	13–1,394	Measured by chewing transducer rolled with the rawhide (22)
	Canine teeth	147–926	Maximum bite force measurement by electronic stimulations (26)
	Molar teeth	574–3,417	
	Canine teeth	300*	Bite force estimation using equations of Kiltie (27)
		340*	Thomason (28)
		571*	Kiltie (26) (adjusted)
		588*	Thomason (26) (adjusted)
	Molar teeth	755*	Kiltie (27)
		849*	Thomason (28)
		1,949*	Kiltie (26) (adjusted)
		2,036*	Thomason (26) (adjusted)
	Canine teeth	351.5*	Bite force estimation using Thomason's equation (29)
	Carnassial teeth	549.8*	
	Canine teeth	231.99–511.80 <sup>ab</sup>	Bite force estimation using finite element analysis (35)
	Carnassial teeth	620.33–1,091.1 <sup>b</sup>	

[1] Figure 1 - Measurements of bite force in dogs

### References:

[1] Kim, S. E., Arzi, B., Garcia, T. C., & Verstraete, F. (2018). Bite Forces and Their Measurement in Dogs and Cats. *Frontiers in veterinary science*, 5, 76.

### Conclusions/action items:

Although we already had information on the canine bite force, I am now more familiar with the background of the pressures on the fracture site and can use this information when doing FEA simulations.





## 2020/12/5 - Impact of Nylon Muzzle

---

Sydney Appleton - Dec 05, 2020, 11:58 AM CST

**Title:** Importance and Impact of Nylon Muzzle

**Date:** 12/5/2020

**Content by:** Sydney Appleton

**Present:** Sydney Appleton

**Goals:** Indicate the broader impact of a nylon muzzle.

**Content:**

Since mandibular fractures in canines are expensive injuries that are very common and make up 1.5 to 3 percent of all fractures in canines, it is crucial to have alternative treatment options [1]. Currently, these surgeries can range anywhere from 1000 to 2000 dollars and many pet owners cannot afford to have this procedure done which may lead to euthanasia [2]. Currently, tape muzzles are the standard non invasive treatment for mandibular fracture repairs in canines used to stabilize the fracture, but their placement can cause a pivot point around the fractured tooth causing more displacement and pain. Nylon muzzles on the other hand can provide an alternative to surgery or provide greater stability before and after surgery by distributing the bite forces of a canine mandible more evenly than that of a tape muzzle.

Our client, Dr. Thatcher, believes that nylon muzzles are the superior treatment option for mandibular fracture repairs in canines. By quantitatively proving that nylon muzzles more evenly distribute the bite forces in the jaw, costly surgeries can be eliminated and improvement in the stabilization through these nylon muzzles can become the standard treatment ultimately saving and improving the quality of the dogs life.

**References:**

[1] C. Kunz, N. Adolphs, P. Büscher, B. Hammer, and B. Rahn, "Mineralization and mechanical properties of the canine mandible distraction wound following acute molding," *International Journal of Oral and Maxillofacial Surgery*, vol. 35, no. 9, pp. 822–827, 2006.

[2] S. E. Kim, B. Arzi, T. C. Garcia, and F. J. M. Verstraete, "Bite Forces and Their Measurement in Dogs and Cats," *Frontiers in Veterinary Science*, vol. 5, 2018.

**Conclusions/action items:**

This information indicates the societal/global impact and the motivation behind our research and project.



## 2020/9/16 - Background on Bridge Mechanics

Sydney Appleton - Dec 05, 2020, 11:19 AM CST

### Title: Background Research on Bridge Mechanics for the Muzzle Design

Date: 9/16/2020

Content by: Sydney Appleton

Present: Sydney Appleton

Goals: Further my understanding of the Suspension and Cantilever Bridge Mechanics.

### Content:

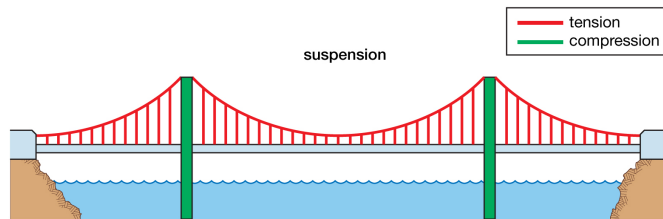

© 2012 Encyclopædia Britannica, Inc.

(Figure 1 - Suspension Bridge [2])

Suspension Bridges: Cables descend from two tall towers which support most of the weight by receiving the compression running up the cables. The supporting cables receive the tension forces and run to anchorages which pass the forces to the ground. There is also a deck truss which reduces swinging of the road [1].

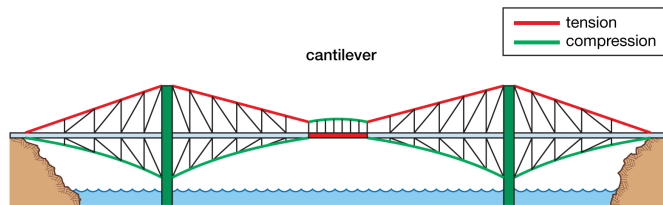

© 2012 Encyclopædia Britannica, Inc.

(Figure 2 - Cantilever Bridge [2])

Cantilever Bridge: Beam projects outward and supported at one end. There are usually three parts to bridge where the outer spans are anchored to the ground and cantilever out toward the middle. The middle span rests on the projected arms where vertical loads are carried with tension forces in lower chords and compression in the upper chords. On the other hand, cantilevers carry the tensions in the upper chords and compression in the lower chords. [2] These types of bridges are commonly used in many civil, mechanical, and aerospace engineering and use mechanics of bending moment, shear, strain, and stress. The shear stress is zero at the boundaries and distributed across the section as a parabola. The normal stress is zero on the surface. These details demonstrate the ability to model fixed and loaded boundary conditions for both straight edges and corners. [4]

Cantilevers in Dentistry: Wire is attached to a removable piece while the end is tied to another unit. The force applied may be approximated by measuring the length of the appliance and its force through a dynamometer. Moment and force produced where cantilever is placed ( $M=F \times d$  where  $F$  is the force and  $d$  is the length of the cantilever). The forces at both ends hold their direction and decrease in a linear manner (cantilever deactivation). This also has a consistent ratio of moment/force, so there is homogeneous dental movement. The deflection ratio produced by the cantilever should be as low as possible to maintain consistency. [3]

### Resources:

[1] Lamb, Robert, and Michael Morrissey. "How Bridges Work." *HowStuffWorks Science*, HowStuffWorks, 7 Apr. 2020, science.howstuffworks.com/engineering/civil/bridge6.htm.

[2] Billington, Philip N., and Hubert Shirley-Smith. "Bridge ." *Encyclopædia Britannica*, Encyclopædia Britannica, Inc., 7 May 2020, www.britannica.com/technology/bridge-engineering/Truss.

[3] "Procedures - Cantilever Mechanics." *PanOrthodontics*, PanOrthodontics, www.panorthodontics.com/procedures-cantilever-mechanics/.

[4] Arora, Jasbir Singh. *Introduction to Optimum Design*. 4th ed., Academic Press, 2017.

### Conclusions/action items:

We can use this information about force load from different bridges to accurately design a our muzzle for recovery from a canine fractured mandible.



## 2020/9/30 - Finite Element Analysis in SolidWorks

---

Sydney Appleton - Oct 07, 2020, 10:32 AM CDT

**Title:** Finite Element Analysis Research in SolidWorks

**Date:** 9/30/2020

**Content by:** Sydney Appleton

**Present:** Sydney Appleton

**Goals:** Obtain more knowledge on how to carry out FEA in SolidWorks.

**Content:**

Steps for Finite Element Analysis:

1. Create a geometric model such as a part.
2. Assign material to every part of the model.
3. Start a simulation.
4. Process of "meshing" - Split it into smaller pieces called entities to approximate the geometry.
5. Create new simulation
6. Apply restraints as to how its held in place.
7. Define the loads acting on components.
8. Solve the Finite Element problem.
9. View the results on the color plots and reports and analyze the corresponding failure points of interest.
10. Refine the mesh until results converge.

[http://community.wvu.edu/~bpbettig/MAE456/Tutorial\\_1\\_Using\\_SolidWorks\\_for\\_FEA.pdf](http://community.wvu.edu/~bpbettig/MAE456/Tutorial_1_Using_SolidWorks_for_FEA.pdf)

**Conclusions/action items:**

I will practice what I learned from this tutorial to apply it to our project.

# 2020/11/02 - Hand Calculation Attempt

Sydney Appleton - Dec 08, 2020, 9:16 AM CST

**Title:** Hand Calculation Attempt for Proof of Concept

**Date:** 11/02/2020

**Content by:** Sydney Appleton

**Present:** Sydney Appleton

**Goals:** Attempt to solve the hand calculations and verify the completed ones previously done by other team members.

**Content:**

I was able to verify the calculations done without support and got the same numbers previously stated. As for the tape muzzle and nylon muzzle, I was unsuccessful in my attempt to solve for the bending moment and shear at the fracture point A and support forces of the distributed loads of the tape and the muzzle. As shown in the attachment below, I was unable to solve for any of the unknowns in the tape muzzle and nylon muzzle diagrams as I did not have the appropriate equations for determinacy.

**Conclusions/action items:**

My calculations without support matched the ones done previously, so those are verified. Since I have only taken statics, I do not know if there is another way to go about this problem. I know we had talked about simplifying this by approximating the force as equal and opposite as the bite forces above; however, I will continue to discuss this with the team.

Sydney Appleton - Dec 08, 2020, 9:12 AM CST

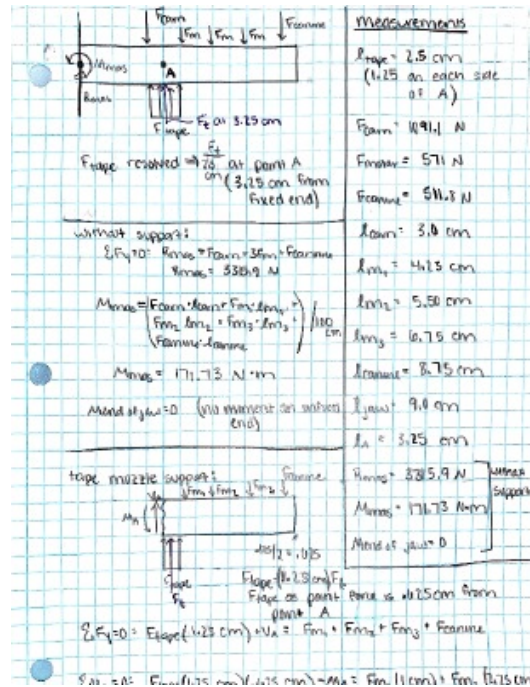

Proof\_of\_Concept\_Attempt.pdf(1.3 MB) - download Attachment 1: Proof of Concept Attempt



## 2020/11/25 - FEA Model

Sydney Appleton - Dec 06, 2020, 2:03 PM CST

### Title: Simplified Mandible Model in SolidWorks

Date: 11/25/2020

Content by: Sydney Appleton

Present: Sydney Appleton

Goals: Create a simplified mandible in SolidWorks to perform FEA on.

### Content:

After playing around with different parts in SolidWorks, I used the dimensions from the Jaw scans to create a simplified model of the mandible. I attempted to create a model that accurately represents the shapes and curvature of the bottom jaw. I included a triangle part to represent the M1 tooth where the fracture occurs. I still need to assign a material and put a crack in the tooth to simulate the fracture site.

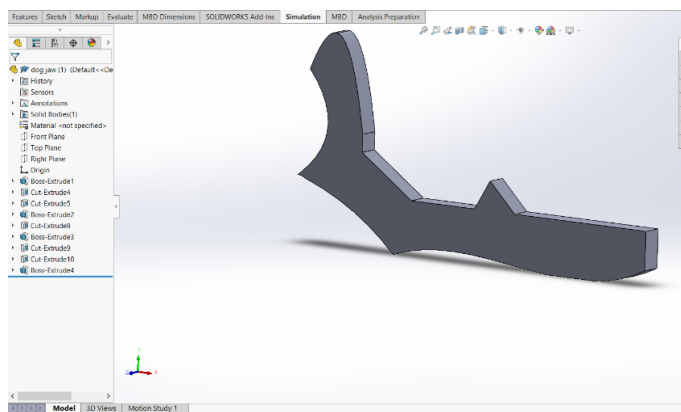

Figure 1: Simplified Mandible Model

### Conclusions/action items:

I will use the mandible I created to attempt a SolidWorks FEA simulation.





## 2020/11/28 and 2020/11/29 - FEA Simulation Attempts

Sydney Appleton - Dec 06, 2020, 2:11 PM CST

### Title: Finite Element Analysis Attempts in SolidWorks

Date: 11/28/2020 and 11/29/2020

Content by: Sydney Appleton

Present: Sydney Appleton

Goals: Figure out the SolidWorks simulation for FEA analysis.

#### Content:

I used the

#### Attempt 1 - 11/28/2020:

This attempt was unsuccessful as I was unable to even get the simulation to run. At first, I created the "crack" in the jaw by extruding a triangle piece. I used this model and applied a distribution of forces to represent the bite forces from different teeth. The simulation did not work, so I changed how it was fixed at the left end of the jaw where it would attach to the skull.

#### Attempt 2 - 11/29/2020:

In this simulation, the program started to run; however, it sat for 15 minutes trying to carry out the analysis and ended up crashing as shown in Figure 1. I tried changing the forces, meshing, and fixtures to be where I wanted them, but it still ended up crashing.

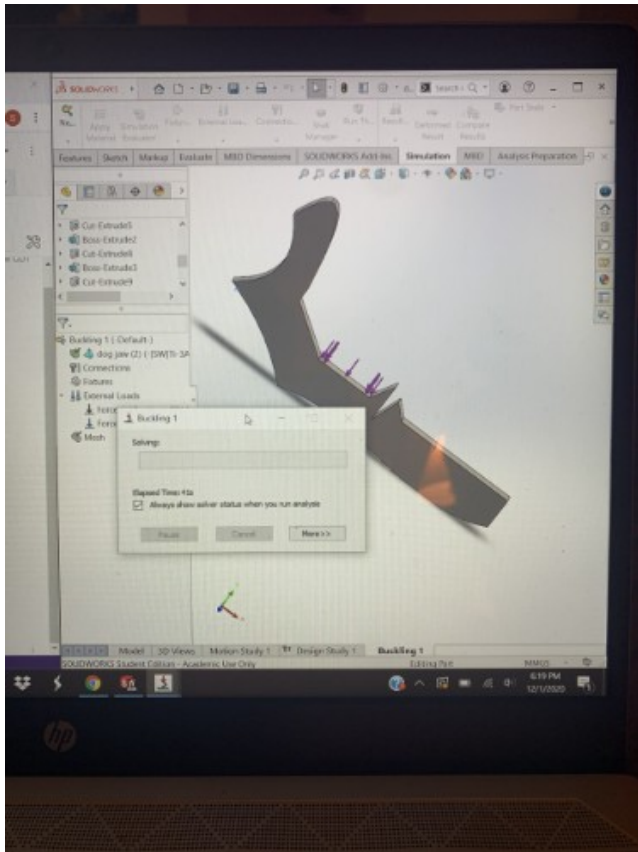

Figure 1: FEA Simulation Attempt

#### Conclusions/action items:

Although I was unsuccessful, I will continue to work with the team as we figure out the simulation. I will research more on fixtures and forces to continue to improve the simulation.



## 2020/10/15 - Polypropylene

Sydney Appleton - Oct 16, 2020, 8:58 AM CDT

### Title: Polypropylene Properties

**Date:** 10/15/2020

**Content by:** Sydney Appleton

**Present:** Sydney Appleton

**Goals:** To learn more about the properties of Polypropylene, which is a material we are considering to use for the battens.

### Content:

[1]

### Properties:

- Semi-rigid (Polyethylene is of higher rigidity and hardness)
- Translucent
- Good chemical resistance
- Tough (no stress-cracking problems)
- Good fatigue resistance
- Integral hinge property
- Good heat resistance

### Chemical Structure

- Linear hydrocarbon, little or no unsaturation
- Methyl at every other backbone carbon leads to stiffening of chain and interferes with molecular symmetry
- Manufactured through slurry, solution, or gas-phase processes - different catalysts can alter properties

### Grades available

- Homopolymers - general purpose with numerous applications, stronger and stiffer
- Block Copolymers - Improved impact resistance (5-15% ethylene) and can have increase toughness with mixtures with elastomers, better impact and more transparent
- Random Copolymers - 1-7% ethylene, arrange random co-monomer units along polypropylene long chain molecule, lower melting point, more flexibility, and enhanced clarity

### Physical Properties

Tensile Strength	0.95 - 1.30 N/mm <sup>2</sup>
Notched Impact Strength	3.0 - 30.0 Kj/m <sup>2</sup>
Thermal Coefficient of expansion	100 - 150 x 10 <sup>-6</sup>
Max Cont Use Temp	80 °C
Density	0.905 g/cm <sup>3</sup>

[1] Figure 1 - Physical Properties or Polypropylene

### Resources

[1] Bpf. "Polypropylene (PP)." *British Plastics Federation*, [www.bpf.co.uk/plastipedia/polymers/pp.aspx](http://www.bpf.co.uk/plastipedia/polymers/pp.aspx).

**Conclusions/action items:** I will share this information with the team as we discuss our Materials Design Matrices.





## 2020/10/15 - Nylon (Polyamide)

Sydney Appleton - Oct 16, 2020, 9:09 AM CDT

### Title: Nylon (Polyamide) Properties

Date: 10/15/2020

Content by: Sydney Appleton

Present: Sydney Appleton

Goals: To learn more about the properties of Nylon, specifically Polyamide, which is a material we are considering to use in the battens.

### Content:

[1]

### Properties

- Tough with good chemical and thermal resistance
- Specific gravity, melting point, and moisture content varies - reduce as nylon number goes up
- Absorb moisture until equilibrium - negative effect on dimensional stability
- Impact resistance and flexibility increase with moisture content (strength and stiffness decreases)

### Types

- Homopolymer
- Copolymer
- Reinforced
- Often blended to improve aspects of performance

### Physical Properties

Tensile Strength 90 - 185 N/mm<sup>2</sup>

Notched Impact Strength 5.0 - 13 Kj/m<sup>2</sup>

Thermal Coefficient of expansion 90 - 20/70 x 10<sup>-6</sup>

Max Cont Use Temp 150 - 185 oC

Density 1.13 - 1.35/1.41 g/cm<sup>3</sup>

[1] Figure 1: Physical Properties of Nylon

### Resources:

[1] Bpf. "Nylons (Polyamide)." *British Plastics Federation*, BPF, [www.bpf.co.uk/plastipedia/polymers/polyamides.aspx](http://www.bpf.co.uk/plastipedia/polymers/polyamides.aspx).

### Conclusions/action items:

I will use this information to discuss the design matrices with the team.



## 2020/10/15 - Aluminum/Other Metal

Sydney Appleton - Oct 16, 2020, 9:18 AM CDT

### Title: Aluminum Properties

Date: 10/15/2020

Content by: Sydney Appleton

Present: Sydney Appleton

Goals: To learn more about the properties of Aluminum, which is a material we are considering to use for the battens.

### Content:

[1]

### Properties

- Lightweight, durable, malleable, corrosion-resistant
- Easily machined and casted

PROPERTY	METRIC	UNITS	ENGLISH	UNITS
<b>General</b>				
Density	2.5e3 - 2.9e3	kg/m <sup>3</sup>	156 - 181	lb/ft <sup>3</sup>
<b>Mechanical</b>				
Yield Strength	3e7 - 5e8	Pa	4.35 - 72.5	ksi
Tensile Strength	5.8e7 - 5e8	Pa	8.41 - 79.8	ksi
Elongation	0.01 - 0.44	% strain		% strain
Hardness (Vickers)	1.18e8 - 1.48e9	Pa		HV
Impact Strength (un-notched)	1.9e5 - 2e5	J/m <sup>2</sup>		ft.lbf/in <sup>2</sup>
Fracture Toughness	2.2e7 - 3.5e7	Pa/m <sup>0.5</sup>	20 - 31.9	ksi/in <sup>0.5</sup>
Young's Modulus	6.8e10 - 8.2e10	Pa	9.86 - 11.9	10 <sup>6</sup> psi
<b>Thermal</b>				
Max Service Temperature	120 - 210	°C	248 - 410	°F
Melting Temperature	475 - 677	°C	887 - 1.25e3	°F
Insulator or Conductor	Good	Conductor		Good Conductor
Specific Heat Capability	857 - 990	J/kg °C	0.205 - 0.236	BTU/lb. °F
Thermal Expansion Coefficient	2.1e-5 - 2.4e-5	strain/°C	11.7 - 13.3	μstrain/°F

[1] Figure 1: Properties of Aluminum

### Resources:

[1] Dielectric Manufacturing. "Characteristics, Applications and Properties of Aluminum." *Dielectric Manufacturing*, Dielectric Manufacturing, 28 May 2020, [dielectricmfg.com/knowledge-base/aluminum/](https://dielectricmfg.com/knowledge-base/aluminum/).

### Conclusions/action items:

I will share this information with the team as we discuss our materials design matrices.



## 2020/10/16 - Cotton

Sydney Appleton - Dec 06, 2020, 11:21 AM CST

### Title: Cotton Properties

Date: 10/16/2020

Content by: Sydney Appleton

Present: Sydney Appleton

Goals: To learn more about the properties of Cotton, which is a material we are considering to use in the mesh.

Content:

### Properties [1]

- Comfortable to wear
- Natural, cellulosic fiber
- Absorbs water and “breathes”
- Slow to dry
- Resists static electricity build-up
- Wrinkles easily
- Can withstand heat, detergents, and bleach
- About 20% stronger when wet than dry
- Will shrink unless treated
- Can be damaged by mildew
- Can be damaged by prolonged exposure to sunlight
- Raw - \$0.75 per pound
- Moderately strong, tenacity = 3-5 g, per denier
- Relatively less elastic (1.5-1.58)
- Abrasion resistance: medium
- Low resiliency

**Physical Properties of Cotton:** Physical properties of cotton fibers are given below:

1. **Color:** The color of cotton fiber could be white, creamy white, bluish white, yellowish white or grey.
2. **Tensile Strength:** Cotton is moderately strong fiber. It has a tenacity of 3-5 gm/den. The strength is greatly affected by moisture; the wet strength of cotton is 20%, which is higher than dry strength.
3. **Elongation at break:** Cotton does not stress easily. It has an elongation at break of 5-10%.
4. **Elastic Recovery:** Cotton is inelastic and rigid fiber. At 2% extension it has an ER of 74% and at 5% extension it has an ER of 45%.
5. **Specific Gravity:** Specific gravity is 1.54.
6. **Moisture Regain (MR %):** Standard moisture regain is 8.5.
7. **Effect of Heat:** Cotton has an excellent resistance to degradation by heat. It begins to turn yellow after several hours at 120°C and decomposes marked by at 150°C. As a result of oxidation, cotton is severally damaged after few minutes at 240°C. Cotton burns in air.
8. **Effect of Sun Light:** There is a gradual loss of strength when cotton is exposed to sun light and the fiber turn yellow. The degradation of cotton by oxidation is done when heat is promoted and encouraged. By sun light much of the damage is caused by UV-light and by the shorten weaves of visible light.
9. **Effect of Age:** Cotton shows a small loss of strength when stored carefully. After 50 years of storage cotton may differ only slightly from the new fibers.

### [2] Figure 1 - Physical Properties of Cotton

**Chemical Properties of Cotton:** Cotton is a natural cellulosic fiber and it has some chemical properties. Chemical properties of the cotton fiber are given below:

1. **Effect of Acids:** Cotton is attacked by hot dilute acids or cold concentrated acids which it disintegrates. It is not affected by acids.
2. **Effects of Alkalis:** Cotton has an excellent resistance to alkalis. It swells in caustic alkalis (NaOH) but it does not damaged. It can be washed repeatedly in soap solution without any problem.
3. **Effect of Organic Solvent:** Cotton has high resistance to normal cleaning solvents. Cotton is dissolved by the copper complexes, such as cuprammonium hydroxide, cupriethylene diamine and concentrated 70% H<sub>2</sub>SO<sub>4</sub>.
4. **Effects of Insects:** Cotton is not attacked by moth-grubs or beetles.
5. **Effect of Micro Organism:** Cotton is attacked by fungi and bacteria. Mildews will feed on cotton fabric, rotting and weakling the materials. Mildews and bacteria will flourish on cotton under hot and humid condition. They can be protected by impregnation with certain types of chemicals. Copper Nephenate is one of the chemical.

### [2] Figure 2 - Chemical Properties of Cotton

### Resources

- [1] “Cotton Fibers and Its Properties.” *Textile School*, 13 Mar. 2018, [www.textileschool.com/164/cotton-fibers-and-its-properties/](http://www.textileschool.com/164/cotton-fibers-and-its-properties/).

[2] "Cotton Fiber - Physical and Chemical Properties." Textile Fashion Study, 23 June 2012, [textilefashionstudy.com/cotton-fiber-physical-and-chemical-properties-of-cotton/](http://textilefashionstudy.com/cotton-fiber-physical-and-chemical-properties-of-cotton/).

**Conclusions/action items:**

I will share this information with the team while discussing our final material matrices.



## 2020/10/16 - Polyester

Sydney Appleton - Dec 06, 2020, 11:23 AM CST

### Title: Polyester Properties

**Date:** 10/16/2020

**Content by:** Sydney Appleton

**Present:** Sydney Appleton

**Goals:** To learn more about the properties of Polyester, which is a material we are considering to use in the mesh.

### Content:

[1]

### Properties:

- Combination of dialcohols and diacids so numerous forms
- Easily molded
- High strength and toughness
- Good abrasion
- Good heat resistance
- Good chemical resistance
- Excellent dimensional stability
- Excellent crease and wear resistance
- Low moisture absorption
- Easy to care for
- Lower breathability
- Resistance to stretching and shrinkage
- Static and pilling problems
- Attracts static electricity - dust and lint

**Physical Properties of Polyester:** Like *cotton* or other fiber, polyester fiber consists of some important physical properties. Important physical properties of polyester are given below.

1. *Tenacity:* 5 – 7 gm/den
2. *Elongation at break:* 15 – 30%
3. *Elastic modulus:* 90
4. *Elasticity:* Good
5. *Moisture Regain (MR%):* 0.40%
6. *Specific Gravity:* 1.38
7. *Melting point:* 250°C
8. *Volumetric Swelling:* None
9. *Ability to protest friction:* Excellent
10. *Color:* White
11. *Light reflection ability:* Good
12. *Lusture:* Bright

### [2] Figure 1 - Physical Properties of Polyester

**Chemical Properties of Polyester:** Various types of chemical properties of polyester fiber are given below:

1. *Acids:* Good resistance to acids in cold condition. But polyester degrades by  $H_2SO_4$  at high temperature.
2. *Basic:* Good resistance to basic in cold condition but Strong NaOH dissolves polyester in boiling.
3. *Effect of bleaching:* Polyester does not affected by bleaching process.
4. *Organic solvent:* Organic solvent does not affect on polyester fiber.
5. *Protection ability against mildew:* Good
6. *Protection ability against insects:* Good
7. *Dyes:* Polyester could be dye with disperse, azoic color and some pigments.
8. *Solvents of polyester:* Following are the solvents of polyester:
  - Chlorinated hydrocarbon.
  - $F_3COOH$
  - Phenol (in hot condition)

### [2] Figure 2: Chemical Properties of Polyester

### Resources:

[1] "Polyester Fiber and Its Uses." *Textile School*, 22 Mar. 2019, [www.textileschool.com/234/polyester-fiber-and-its-uses/](http://www.textileschool.com/234/polyester-fiber-and-its-uses/).



[2] "Polyester - Physical and Chemical Properties." Textile Fashion Study, 26 June 2012, [textilefashionstudy.com/polyester-physical-and-chemical-properties-of-polyester/](http://textilefashionstudy.com/polyester-physical-and-chemical-properties-of-polyester/).

**Conclusions/action items:**

Using this information and the information from the other team members, we will complete our materials design matrices.



## 2020/10/4 - Nylon Properties and Cost

Sydney Appleton - Dec 06, 2020, 11:22 AM CST

**Title:** Research on Nylon material

**Date:** 10/4/2020

**Content by:** Sydney Appleton

**Present:** Sydney Appleton

**Goals:** Learn more about the material we are using.

**Content:**

Properties of Nylon [1]:

- Strong and elastic
  - Stronger than polyester fabrics
- Tough with abrasion resistance
- Easy to clean
- Variety of colors available
- Smooth, soft, lightweight filament yarns
  - Still high resilience
- Excellent tensile strength and elasticity
- Does not burn
  - Decent heat resistance
- Poor resistance to sunlight
- Decent wrinkle and static resistance
- Used in products such as ropes, seat belts, conveyer belts, etc.

**Physical Properties of Nylon 6:** Physical properties of nylon are given below.

1. **Tenacity:** 6.0 – 8.5 gm/den
2. **Density:** 1.14 gm/c.c
3. **Elongation at break:** 15 – 45%
4. **Elasticity:** Very good
5. **Moisture Regain (MR%):** 3.5 – 5%
6. **Resiliency:** Good
7. **Melting point:** 215°C
8. **Ability to protest friction:** Excellent
9. **Color:** White
10. **Light reflection ability:** Not good.
11. **Ability to protect heat:** Up to 150°C
12. **Lusture:** Bright to light

[3] Figure 1: Physical Properties of Nylon

**Chemical Properties of Nylon 6:** Chemical properties of nylon 6 are given below.

1. **Acids:** Like nylon 6.6, nylon 6 has not enough ability against acidic action.
2. **Basic:** Basic does not cause harm to the nylon 6. Nylon 6 has enough ability against alkali.
3. **Effect of bleaching:** Strong oxidizing agent is harmful for the nylon 6.
4. **Organic solvent:** It becomes soluble in any dense acid or phenol.
5. **Protection ability against mildew:** Mildew cannot cause harm to the nylon 6.
6. **Protection ability against insects:** Insects cause harm to the nylon 6.
7. **Dyes:** Nylon 6 could be dye by **Direct dyes**, Acid dyes and **vat dyes**.

[3 ] Figure 2: Chemical Properties of Nylon

Cost of Nylon [2]:

- Relatively expensive compared to other polyesters
- Nylon-6 (per pound): Low: \$1.23, High: \$1.47, Current: \$1.23-\$1.36
- Nylon-6/6 (per pound): Low: \$1.38, High: \$1.64, Current: \$1.38-\$1.46

Resources:

[1] "Polymer Properties Database." *Nylon Fibers*, Polymer Properties Database, [polymerdatabase.com/Fibers/Nylon.html](http://polymerdatabase.com/Fibers/Nylon.html).

[2] "Chemical Profile - NYLON-6 and NYLON-6/6." *ICIS Explore*, Reed Business Information, [www.icis.com/explore/resources/news/2005/12/02/549810/chemical-profile-nylon-6-and-nylon-6-6/](http://www.icis.com/explore/resources/news/2005/12/02/549810/chemical-profile-nylon-6-and-nylon-6-6/).

[3] "Polyamide Fiber - Physical and Chemical Properties of Nylon 6." *Textile Fashion Study*, 31 Aug. 2012, [textilefashionstudy.com/polyamide-fiber-physical-and-chemical-properties-of-nylon-6/](http://textilefashionstudy.com/polyamide-fiber-physical-and-chemical-properties-of-nylon-6/).

**Conclusions/action items:**

I will use my understanding of the properties of nylon while designing the muzzle. It is also useful for me to know the cost of the material we plan to use when making purchasing decisions because I am the BPAG.



## 2020/9/22 - Preliminary Design

Sydney Appleton - Oct 07, 2020, 10:23 AM CDT

### Title: Preliminary Design - Adjustable Clips and Batten Reinforcements

Date: 9/22/202

Content by: Sydney Appleton

Present: Sydney Appleton

Goals: Create an initial design to share with the team.

#### Content:

My goal with this design was to have flexible reinforcements spread out throughout the bottom and side of the muzzle. I wanted to do this with battens which increase the support around the mandible. I also hoped to make the muzzle as adjustable as possible in order to make it user friendly and give it the ability to secure the jaw of different sized heads. In the back, the two sides loop through the head piece in an attempt to increase support as well.

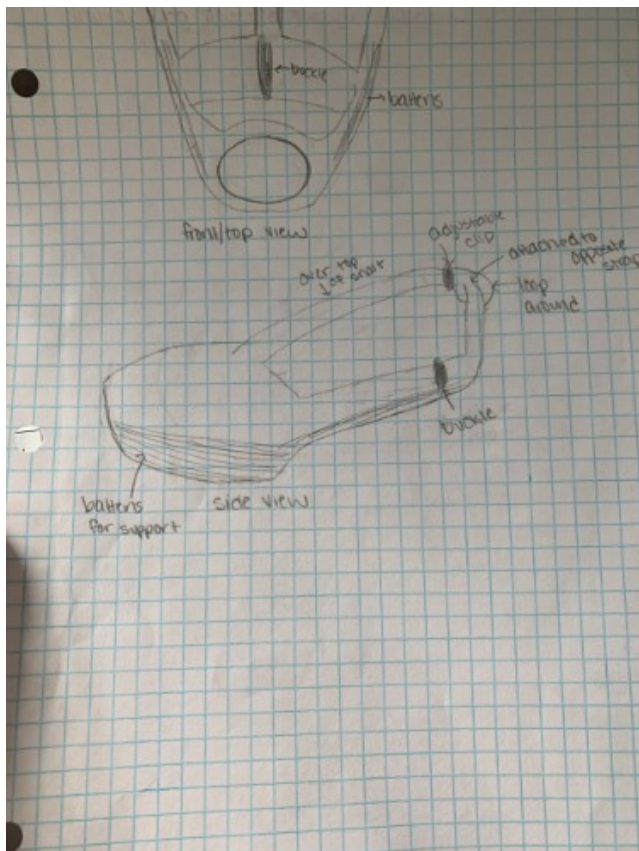

Figure 1: Adjustable Clip and Reinforced Batten Muzzle Design

#### Conclusions/action items:

I will present my ideas with the team during our meeting and explain my reasoning behind my decisions.

# 2020/10/01 - Fabrication Plan

Sydney Appleton - Nov 18, 2020, 10:47 AM CST

**Title:** Fabrication Plan

**Date:** 10/1/20

**Content by:** Sydney Appleton and Alexandria Thao

**Present:** Sydney Appleton and Alexandria Thao

**Goals:** Design a basic fabrication plan and discuss where to purchase our materials.

**Content:**

## Fabrication Plan

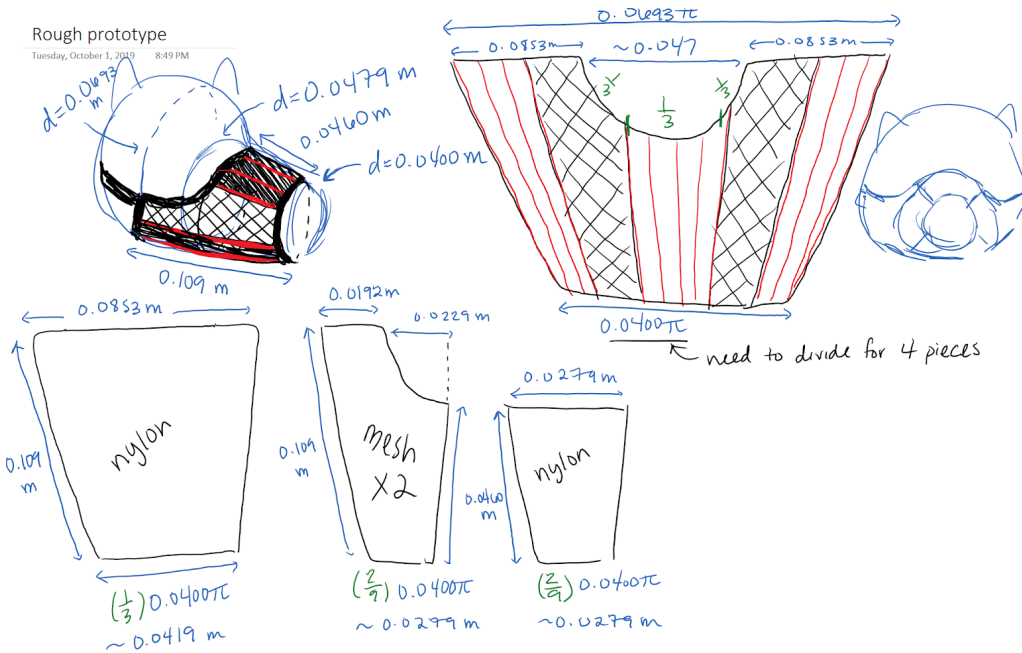

- 4 separate pieces sewn together → 1 bottom nylon piece, 1 top nylon piece, 2 side mesh pieces
- Need to add on few mm to account for muscle, skin, and fur → also need to add extra mm hem allowance

### Where to purchase and prices?

#### Polyamide

- Sheets available from:
  - midland plastics or fleckface.com (TeamLab suppliers)
  - Shop@UW from Fischer Scientific
- Can be 3D printed at Makerspace using Ultimaker printers → \$0.12 per gram

#### Polypropylene

- Sheets available from:
  - midland plastics or fleckface.com
- Can be 3D printed at Makerspace using Ultimaker printers → \$0.13 per gram

#### Aluminum

- Can buy sheets on Shop@UW from WW Grainger
- Can buy sheets on Shop@UW from MSC Industrial Supply Co.

## Nylon

- Mesh sheets available on (non-Shop@UW):
  - <https://www.fabricwholesaledirect.com/products/power-mesh-fabric?variant=11088926470> (\$3.99/yd)
  - Performance Nylon Spandex Power Mesh Fabric Black at JoAnn's \$8.99/yd (minimum 2 yards)
  - Solid Power Mesh Fabric Nylon Spandex - FWD on Amazon (1 yd - \$6.99)
- Non-Mesh sheets:
  - [Ripstop Nylon Fabric 59" Solids](#)
- Other
  - Nylon straps - [Joann's](#)
  - Buckle - [Joann's](#)
- **Optional** - corset bone casing to insert supports into, no need to make own folds in muzzle
  - Polyester bone casing - \$8.99 from [Amazon](#)

**Conclusions/action items:**

We will share this with the team to finalize our purchasing sites and prices.



## 2020/12/6 - Analysis and Discussion of Results

---

Sydney Appleton - Dec 08, 2020, 9:27 AM CST

**Title:** Analysis and Discussion of Results

**Date:** 12/06/2020

**Content by:** Sydney Appleton

**Present:** Sydney Appleton

**Goals:** Review our results of the FEA simulation and Model

**Content:**

After running our FEA simulation, we found that the nylon muzzle significantly reduced the pressure on the fracture site compared to no support and tape muzzle support. FEA was run with an average bite force of 855 N where we got a range of stress concentrations resulting from each situation. Peak stresses were decreased around 90% for a nylon muzzle as compared with a tape muzzle and no support. This means there is significantly less stress around the fracture site when using a tape muzzle. Since tape muzzles actually increase the stress concentration due to three-point bending, the nylon muzzle may aid in healing more efficiently and effectively without displacing the jaw further.

Our physical prototype fit well around the canine's snout; however, it still has a long way to go. Support rods and foam were added to increase comfort and protection along with the usage of a spandex nylon and mesh. We have not been able to conduct any experiments with this model, but that would be included in the next steps.

**Conclusions/action items:**

Going forward, we would need to refine our mandible and FEA simulation in SolidWorks to more accurately represent the jaw. After obtaining more suitable materials, including less stretchy, more durable nylon, it would be appropriate to validate the model with real-life experiments on canines if possible. The material components also need to be tested for durability, flexibility, and comfort for the canine through additional tests. This would help us to continue to prove the validity of nylon muzzle usage over tape muzzles.



## 2014/11/03-Entry guidelines

---

John Puccinelli - Sep 05, 2016, 1:18 PM CDT

Use this as a guide for every entry

- Every text entry of your notebook should have the **bold titles** below.
- Every page/entry should be **named starting with the date** of the entry's first creation/activity, subsequent material from future dates can be added later.

You can create a copy of the blank template by first opening the desired folder, clicking on "New", selecting "Copy Existing Page...", and then select "2014/11/03-Template")

**Title:** Descriptive title (i.e. Client Meeting)

**Date:** 9/5/2016

**Content by:** The one person who wrote the content

**Present:** Names of those present if more than just you (not necessary for individual work)

**Goals:** Establish clear goals for all text entries (meetings, individual work, etc.).

**Content:**

Contains clear and organized notes (also includes any references used)

**Conclusions/action items:**

Recap only the most significant findings and/or action items resulting from the entry.





**Title:**

**Date:**

**Content by:**

**Present:**

**Goals:**

**Content:**

**Conclusions/action items:**