

# BME Design-Fall 2020 - Kiley Smith Complete Notebook

PDF Version generated by

**CASSIDY Geddes**

on

Dec 09, 2020 @02:49 PM CST

## Table of Contents

|   |    |
|---|----|
| Project Information   | 2  |
| Team contact Information                                    | 2  |
| Project description   | 3  |
| Team activities   | 4  |
| Client Meetings   | 4  |
| 2020/09/11 First Client Meeting                             | 4  |
| 2020/09/11 1st Client Meeting                               | 5  |
| 2020/09/25 Second Client Meeting                            | 7  |
| 2020/10/30 Client Meeting                                   | 8  |
| 2020/11/13  | 9  |
| 2020/11/20 Client Meeting                                   | 10 |
| Advisor Meetings  | 11 |
| 2020/09/11 1st Advisor Meeting                              | 11 |
| 2020/09/25 2nd Advisor Meeting                              | 12 |
| 2020/10/09 4th Advisor Meeting                              | 13 |
| 2020/10/16 Advisor Meeting                                  | 14 |
| 2020/10/30 Advisor Meeting                                  | 15 |
| 2020/11/06 Advisor Meeting                                  | 16 |
| 2020/11/13 Advisor Meeting                                  | 17 |
| 2020/11/20 Advisor Meeting                                  | 18 |
| Design Process  | 19 |
| 2020/10/30 Show and Tell Post                               | 19 |
| Materials and Expenses                                      | 20 |
| 10/28/20- Materials Spreadsheet                             | 20 |
| Fabrication   | 21 |
| 10/28/2020- Fabrication Plan                                | 21 |
| Chest Holder and Straps Design                              | 22 |
| 10/18/20 Fabrication Planning                               | 22 |
| 10/27/20 Fabrication of Chest Holder and Straps Shoe Design | 25 |
| 11/9/20 Fabrication of Third Straps Prototype               | 27 |
| 2020/11/20 First Chest Holder Pocket Prototype              | 30 |
| 2020/12/09 Chest Holder Design Finished                     | 32 |
| Clip Design   | 38 |
| 2020/10/29 Clip Holder SolidWorks Design                    | 38 |
| Fabrication and Testing of Final Clip Prototypes            | 40 |
| Sensor  | 42 |
| 2020/10/29 Delsys Trigno Sensor                             | 42 |
| 2020/11/18-Circuit Creation and Testing                     | 43 |
| Testing and Results   | 44 |
| Protocols   | 44 |
| 2020/12/09-Updated Testing protocols                        | 44 |
| 2020/11/21-Outdated Testing protocols                       | 45 |
| Experimentation   | 46 |
| 2020/11/9 First Phase of Testing for Straps Design          | 46 |
| 2020/12/02 Kinovea Straps Testing                           | 48 |
| 2020/12/03-Clip Kinovea                                     | 51 |

|   |     |
|---|-----|
| 2020/12/09-Design testing Results                                   | 53  |
| Project Files   | 61  |
| 2020/11/05 .stl File for 3D Printing                                | 61  |
| Team Meetings   | 62  |
| 2020 - Team Meeting   | 62  |
| 2020/09/15-Team Meeting   | 63  |
| 2020/10/16 - Team Meeting   | 64  |
| 2020/11/10 - Team Meeting   | 65  |
| 2020/11/20 - Team Meeting   | 66  |
| 2020/12/01- Testing Meeting   | 67  |
| Emily Johnson   | 68  |
| Research Notes  | 68  |
| Biology and Physiology  | 68  |
| Sept 10- Arch Compression / Recoil while Running                    | 68  |
| Oct 3- Center of Mass During Running                                | 70  |
| Competing Designs   | 72  |
| Sept 12- Compression Shoe Attachment                                | 72  |
| Sept 13- Running Shoe Soles   | 76  |
| Sept 17- Belt with Expandable Pouch                                 | 79  |
| Sept 28- GoPro Chesty   | 80  |
| Sept 28- Camera Harness   | 81  |
| Design Ideas  | 82  |
| Shoe Holder   | 82  |
| Sept 17- Prelim Shoe Holder (Lace it up)                            | 82  |
| Sept 17- Prelim Shoe Holder (Goal Post)                             | 83  |
| Sept 17- Shoe Holder Prelim (Up, Down and All Around)               | 84  |
| Nov 21- Ankle Holder for Testing                                    | 85  |
| Chest Holder  | 86  |
| Sept 17- Prelim Chest Holder (Fanny Pack)                           | 86  |
| Sept 28- Prelim Chest Holder (GoPro)                                | 87  |
| Sept 28- Prelim Chest Holder (Suspenders)                           | 88  |
| Training Documentation  | 89  |
| Oct 3- Green Pass   | 89  |
| Kiley Smith   | 90  |
| Research Notes  | 90  |
| 2020/09/28-Trigno Sensors   | 90  |
| Design Ideas  | 91  |
| 2020/10/05- Shoe holder FBDs  | 91  |
| 2020/10/24- Possible Accelerometers and Microcontroller For Testing | 93  |
| 2020/12/09-FBD Equations  | 95  |
| Ian Schirtzinger  | 96  |
| Research Notes  | 96  |
| Competing Designs   | 96  |
| 09/15/20 - Search for running straps/bands                          | 96  |
| Materials   | 98  |
| Material search   | 98  |
| Second search for Wire  | 99  |
| Design Ideas  | 100 |
| 09/15/2020 - Preliminary Design Options                             | 100 |
| 9/24/20 Clip2.0   | 101 |
| Sensor holder design  | 102 |
| Clip prototype A  | 103 |
| Clip prototype B  | 105 |
| Testing the Clip prototypes   | 106 |
| Quinton Heney   | 107 |
| Design Ideas  | 107 |
| 2020/09/17 Preliminary Design Idea [Shoe Holder]                    | 107 |
| 2020/09/17 Preliminary Design Idea [Chest Holder]                   | 108 |
| 2020/10/01 Solidworks holder design                                 | 109 |
| 2020/10/07 Goal Post Holder SolidWorks Design                       | 112 |
| 2020/10/15 Clip Holder SolidWorks Design                            | 116 |

|  |     |
|--|-----|
| 2020/10/29 Delsys Trigno Sensor .....                  | 119 |
| 2020/12/02- Chest Holder Design Finished .....         | 120 |
| Cassie Geddes .....                                    | 125 |
| Research Notes .....                                   | 125 |
| Biology and Physiology .....                           | 125 |
| 9/18/20 - Materials for Design Ideas .....             | 125 |
| 11/09/20 - Rubber Cement .....                         | 126 |
| Competing Designs .....                                | 127 |
| 9/17/20 - Playermaker Shoe Strap .....                 | 127 |
| 9/17/20 - Xybermind Shoe Strap .....                   | 129 |
| 9/21/20 - Polar Chest Strap .....                      | 131 |
| 10/5/20 - Johnson Health Tech Current Shoe Strap ..... | 132 |
| Sensors and Software .....                             | 133 |
| Trigno Avanti Sensor .....                             | 133 |
| Design Ideas .....                                     | 134 |
| 09/17/2020 - Shoe Strap .....                          | 134 |
| Training Documentation .....                           | 135 |
| 10/6/20 - COE Permits .....                            | 135 |
| 2014/11/03-Entry guidelines .....                      | 137 |
| 2014/11/03-Template .....                              | 138 |



## Team contact Information

Emily Johnson - Oct 07, 2020, 3:45 PM CDT

| Last Name    | First Name | Role         | E-mail                | Phone        | Office Room/Building |
|--------------|------------|--------------|-----------------------|--------------|----------------------|
| Puccinelli   | John       | Advisor      |                       |              |                      |
| Pollman      | Arrington  | Client       |                       |              |                      |
| Smith        | Kiley      | Leader       | kasmith32@wisc.edu    | 262-347-1690 |                      |
| Geddes       | Cassie     | Communicator |                       |              |                      |
| Heney        | Quinton    | BSAC         | heney@wisc.edu        | 414-813-1090 |                      |
| Johnson      | Emily      | BWIG         | erjohnson25@wisc.edu  | 262-825-2775 |                      |
| Schirtzinger | Ian        | BPAG         | ischirtzinge@wisc.edu | 262-203-3775 |                      |



## Project description

---

Emily Johnson - Oct 07, 2020, 3:47 PM CDT

**Course Number:** BME 400

**Project Name:** Johnson Health Tech- EMG Sensor Holder

**Short Name:** Johnson Health Tech

**Project description/problem statement:**

The current methods used by Johnson Health Tech do not do a sufficient job in holding the center of mass and force sensors steady and in place. They use electromyography sensors that also function as accelerometers to collect data. The shoe holders are currently taped to the user with athletic tape that often slips and rolls up. The slippage causes less accurate data while the rolling can cause the user to trip. This project's goal is to create a safer and more stable sensor holder in order to collect more accurate data.

**About the client:**

Arrington Pollmann is an intern and Staci Quam is a project engineer at Johnson Health Tech. They have used Delsys Trigno® sensors in the past to estimate the force and velocity of the limbs and center of mass data and has noticed issues with their current method of securing the sensors to the user and hopes to make the testing process more comfortable for users and lower the chances of greatly extraneous data.



## 2020/09/11 First Client Meeting

---

Kiley Smith - Sep 11, 2020, 12:28 PM CDT

**Title:** First Client Meeting

**Date:** Sept 11, 2020

**Content by:** Kiley Smith

**Present:** Team and clients

**Goals:** To better understand the project and establish requirements

**Content:**

- Delsys trigno emg and accelerometer sensors (1.5x1.5x0.5)
- taped to the back of a shoe
- taped to the center of the body
- Accelerometer is used to measure the force of impact at the base of the heel
- Offered to 3D print the part so we have the exact size of sensor
- 2 sets (four shoe, two center of mass)
- Not a lot of external movement besides what is happening on the shoe, comfortable for the participant
- Adjustable for multiple shoe sizes and body types
- \$500 budget
- Ideal test subject can be running outside or on a treadmill
- Sensors should be able to be swapped out
- Holders could be replaced everytime as long as they are inexpensive
- All the analysis can be done in MATLAB
- Some of the analysis can be done within the program
- Each emg sensor has multiple signals that it can track
- Sensor picks up the activation of the muscles themselves
- Use maximum voluntary contraction for full activation of muscle
- Current methods can change the users gate, slippage of sensors, or the runner could slip

**Conclusions/action items:**

Start looking into different designs to hold the sensors in place and scheduled meetings for every other week at noon.



## 2020/09/11 1st Client Meeting

---

QUINTON HENEY - Sep 11, 2020, 1:58 PM CDT

**Title:** 1st Client Meeting

**Date:** 9/11/2020

**Content by:** Quinton Heney

**Present:** Emily Johnson, Cassidy Geddes, Ian Schirtzinger, Kiley Smith, Clients: Arrington Polman, Staci Quam

**Goals:** Meet with the client and establish expectations for the product

**Content:**

Delsys Trigno EMG and Accelerometer Sensor - can be 3d printed to use as size replica

Placed: taped onto back of shoe, z-axis pointed up, taped to the sides, athletic wrap around shoe

- used for accelerometer, no force plate needed to measure force of impact at heel

Center of mass: tape and wrapped a bunch

sensor goes to back of heel of shoes

6 in total, both heels and center of mass 2x

Center of mass and shoe sensors are the same

Software:

- Taping it and using athletic wrap (like a hurt ankle) currently used (pictures)
- - tape rolls up and becomes burdensome and uncomfortable
- get as csv of acceleration and rotation in each direction data
- analyze on matlab? Maybe a specific software does some analysis
- - each emg sensor has multiple signals it can track
- - Ex: acceleration, x-axis for muscle activation (if on muscle), y-axis, etc...
- - As someone is exercising, the sensor picks up the activation of the muscles and outputs the data (max voluntary contraction for reference)
- - analyze it to find % of activation
- these sensors are being used for just the accelerometer only
- if taped on, they slowly fall off or shift - leads to safety problems or liability, changes gait possibly

Ideal product:

fit securely onto heel and COM without "jostling" around

minimal extraneous movement

be comfortable for the participant

Be adjustable for multiple shoe sizes and body types (heart rate sensor for COM?)

Budget: \$500

Ideal test subject:

running on ground and treadmills

adaptability for general exercise would be nice

Would prefer an adjustable piece that doesn't need to be replaced every time (unless it's very easy and cheap)

No previous groups

**Conclusions/action items:**

Heart Rate Monitor like for COM?

Do sensors need to be on the heels?

- if not: place over the laces or on the side of the shoe?

- full detachable bag with built-in sensor compartment and room for keys, cards, cash, etc...





## 2020/09/25 Second Client Meeting

---

CASSIDY Geddes - Sep 25, 2020, 12:25 PM CDT

**Title:** Second Client Meeting

**Date:** 09/25/2020

**Content by:** Cassidy Geddes

**Present:** Emily Johnson, Cassidy Geddes, Kiley Smith, Clients: Arrington Polman

**Goals:** To update our client with our progress so far, ask any questions we have, and make sure we are on the right track.

**Content:**

- sensor needs to be around distal tibia
- sensor has a little bit of a curve on the edges
- client liked the design that is secured by clip and thin piece under the heel.

**Conclusions/action items:**

Continue to make rough models of designs and create design matrix. The client will ask about getting us a 3D printed model of the sensor next week.



## 2020/10/30 Client Meeting

---

CASSIDY Geddes - Oct 29, 2020, 12:43 PM CDT

**Title:** 10/30/20 Client Meeting

**Date:** 10/30/20

**Content by:** Cassidy Geddes

**Present:**

**Goals:**

- Update client on progress (IMU received, first prototype of strap design, started fabrication of chest strap design)
- Maybe ask for advice for testing? Certain activities that would be good for testing? How to test stability of sensor, etc.
- 

**Content:**

**Conclusions/action items:**

**2020/11/13**IAN SCHIRTZINGER - Dec 09, 2020, 2:24 PM CST

---

**Title: Client Meeting****Date:** 20/11/13**Content by:** Ian**Content:**

Demonstrated the current model of the Clip design and the Straps design both of which the client liked. Discussed that it would be important to ensure that all running shoes have a removable insole. Quinton and I also talked about possible methods for securing the sensors in the Clip design since we were no longer able to 3D print our CAD sensor holder.

**Conclusions/action items:**

Verify that all athletic shoes have a removable insole and brainstorm ways to secure the sensor the wires for the Clip design.



## 2020/11/20 Client Meeting

---

Emily Johnson - Dec 09, 2020, 12:35 PM CST

**Title:** Final Client Meeting prior to Final Deliverables

**Date:** November 20, 2020

**Content by:** Emily Johnson

**Present:** All

**Goals:** Discuss with the clients our final prototypes and get their feedback

**Content:**

The clients were seemingly impressed with our progress. They had a few general questions about the functionality of the devices which were easily answered. The meeting only lasted about 15 minutes and they did not have much feedback for us on the designs themselves. Staci did ask if she could attend the final presentation.

**Conclusions/action items:**

Discuss with Dr. P at advisor meeting later that day if Staci can come. Keep doing what we are doing and finish the semester strong



## 2020/09/11 1st Advisor Meeting

---

CASSIDY Geddes - Sep 11, 2020, 2:06 PM CDT

**Title:** First Advisor Meeting

**Date:** Sept 11, 2020

**Content by:** Cassidy Geddes

**Present:** Team and advisor

**Goals:** To discuss our project and ideas with our advisor to figure out a plan of action.

**Content:**

- Dr. Nimunkar and Dr. Wille are good resources for this project.
- Talked about the project specifications we got from our clients earlier today.

**Conclusions/action items:**

Continue research on the sensors being used, and different materials we could use for the holder. Reach out to Dr. Nimunkar and Dr. Wille if we need help during our project.



## 2020/09/25 2nd Advisor Meeting

---

CASSIDY Geddes - Sep 25, 2020, 2:13 PM CDT

**Title:** Second Advisor Meeting

**Date:** 9/25/2020

**Content by:** Cassidy Geddes

**Present:** All Team Members

**Goals:** Get feedback on design ideas and discuss PDS corrections

**Content:**

- need to quantify details more and included specifications for chest strap
- could have two different sizes of the design: one for smaller shoe sizes and one for larger shoe sizes.

**Conclusions/action items:**

Get slides for preliminary presentation done so that Dr. P can look them over before we record our presentation.



## 2020/10/09 4th Advisor Meeting

---

CASSIDY Geddes - Oct 11, 2020, 12:17 PM CDT

**Title:** 4th Advisor Meeting

**Date:** 10/9/20

**Content by:** Cassidy Geddes

**Present:** All Team Members

**Goals:** To discuss how our presentation went and figure out our next steps.

**Content:**

- Ask Johnson Tech what they look for in their products during the quality testing process. Things we should look for when testing our designs.
- Start fabricating designs and ordering materials we will need
- Email Arrington about getting 3D printed sensor see if it's possible to get actual sensor at some point
- Include drawings labeled with exact material in our next progress report.

**Conclusions/action items:**

Start ordering materials that we need for fabrication, and start the fabrication process for our different designs.



## 2020/10/16 Advisor Meeting

---

Emily Johnson - Dec 09, 2020, 12:15 PM CST

**Title:** Advisor Meeting Week 7

**Date:** October 16, 2020

**Content by:** Emily Johnson

**Present:** Everyone

**Goals:** Discuss with Puccinelli about the progress we have made with the designs

**Content:**

Emily fabricated a proof-of-concept straps design with twine and Ian did the same with everyday materials for the clip design.

Discussed the fabrication plan from these models to functioning ones.

Discussed the research that we found the past week and the solidworks pieces that Quinton had been working on.

**Conclusions/action items:**

Take the discussion and make a working prototype





## 2020/10/30 Advisor Meeting

---

CASSIDY Geddes - Dec 09, 2020, 12:36 PM CST

**Title:** Advisor Meeting Week 9

**Date:** 10/30/20

**Content by:** Cassie Geddes

**Present:** Everyone

**Goals:** Talk about our show and tell post and our goals for the next week.

**Content:**

- Make sure that post can be read in one minute, if they get too long it is harder for people to read and you are likely not going to get as helpful or as much feedback.
- Should be close to having each of our initial prototypes completed
- Start thinking about testing and how we are going to do it
- Important to get testing data for the poster

**Conclusions/action items:**

Make sure our show and tell post is concise and to the point. Also use the feedback we receive to make any necessary changes to our designs. We also need to get the 3-D sensor printed this week.



## 2020/11/06 Advisor Meeting

---

Emily Johnson - Dec 09, 2020, 12:25 PM CST

**Title:** Advisor Meeting Week 10

**Date:** November 6, 2020

**Content by:** Emily Johnson

**Present:** All

**Goals:** Discuss with Dr. P the feedback from Show and Tell and how we might incorporate the ideas

**Content:**

Show and Tell

- Lots of misunderstanding about what our project was
- Possible Future Feedback from the Team- have the one minute blurb to see if they are helpful but give access to more information so they can give better recommendations / feedback
  - Lots of people for us gave ideas that we couldn't due based on the realm of the project
  - Others gave us ideas that we already considered but found not to be feasible

The Project

- Quinton showed the 3-D printed sensor- talked about how we could make a hollow one for the microprocessor for testing
- Short updates on the fabricated prototypes (chest band is en route to Quinton via Kiley from Emily for him to sew)

**Conclusions/action items:**

Research further to determine if any feedback from show and tell was useful.

Fabricate updated prototypes with better materials



## 2020/11/13 Advisor Meeting

---

QUINTON HENEY - Dec 09, 2020, 2:44 PM CST

**Title:** Advisor Meeting Week 11

**Date:** November 13, 2020

**Content by:** Quinton Heney

**Present:** Cassie Geddes, Quinton Heney, Ian Schirtzinger, Kiley Smith

**Goals:** Quickly discuss 3D printing and finishing our prototypes with Dr. P after the Tong lecture

**Content:**

- Quinton and Ian discussed the possibility of 3D printing the SolidWorks models, created for preliminary designs, as possible sensor holder designs.

**Conclusions/action items:**

3D print 2 more sensors for prototyping.

Adjust the 3D models for the preliminary sensor holders in SolidWorks to allow for better fit of the sensor.



## 2020/11/20 Advisor Meeting

---

CASSIDY Geddes - Dec 09, 2020, 12:44 PM CST

**Title:** Advisor Meeting Week 12

**Date:** 11/20/20

**Content by:** Cassie Geddes

**Present:** Entire Team

**Goals:** To discuss our plans for finishing out the semester and the final deliverables.

**Content:**

- Asked if our client can attend the final poster presentation - since it is just us watching the video and questions we can send the link to the video to the client.
- We have final prototypes of each design, but need to clean up wires on the clip design
- Make sure all photos are labeled for the final deliverables

**Conclusions/action items:**

Finish testing as well as the final deliverables.



## 2020/10/30 Show and Tell Post

IAN SCHIRTZINGER - Oct 30, 2020, 7:36 PM CDT

**Title:** Show and Tell Piazza Post

**Date:** 10/30/20

**Content by:** Quinton

**Present:**

**Goals:** Create a post with a call to action to upload to piazza.

**Content:**



Figure 1: The graphic being used in the post. A and B correlate to the *Straps* design and show a side and back view. C and D correlate to the *Clip* design and show a 3/4 view from the back and a top-down view.

The biggest obstacle that we have run into during our design process is determining the best materials to use for the designs and how to make sure the sensor stays stable in each design. Currently we have two different designs that we are working on to stabilize a IMU sensor on the back of a runner's shoe. One design wraps loops through the laces, and the other clips onto the back of the runner's shoe. We are going to be testing two designs to determine the best method, so ideas for either of the designs, pictured in figure 1 below, are welcome. The design must be lightweight and comfortable so it does not change the runner's gait, and for accurate data collection the sensor must be kept stable during physical activities such as running. We are using a 3D printed model of the sensor in conjunction with an IMU for our testing since we are not able to get the actual sensors from Johnson Health Tech right away.



## 10/28/20- Materials Spreadsheet

---

Emily Johnson - Oct 28, 2020, 12:55 PM CDT

**Title:** Material Spreadsheet

**Date:** October 28, 2020

**Content by:** Emily Johnson

**Present:** All- in a way

**Goals:** Document the materials we have purchased for our project

**Content:**

Connected is the Google Sheets

<https://docs.google.com/spreadsheets/d/1fxvwZv3G3NUnNODV46UtlQripahRHvzA2pkDcY2Vb4/edit?usp=sharing>

**Conclusions/action items:**

Make sure to keep in budget and produce a clean final prototype



## 10/28/2020- Fabrication Plan

---

QUINTON HENEY - Oct 29, 2020, 2:14 PM CDT

**Title:** Fabrication Plan

**Date:** October 28, 2020

**Content by:** Emily Johnson

**Present:** NA

**Goals:** Articulate a plan that will allow us to accomplish all that we want in the remaining weeks of the semester.

**Content:**

Chest Holder:

- Team Members: Emily and Cassie
- Learn how to sew the pocket for the sensor
- Sew the ends of the elastic band
- Complete prototype by November 5
- Adjust and fabricate final prototype by November 20
- If the fanny pack is not reliable and adjustments to severe, fabricate the mounted harness design

Shoe Holder:

- The Strap Design
  - Team Members: Emily and Cassie
  - Research new materials to improve the first two prototypes (in straps fabrication folder)
  - Make the new prototype by November 8
  - Adjust and fabricate final prototype by November 20
- The Clip Design
  - Team Members: Ian (Quinton can also help)
  - Get the first prototype done by November 5
  - Adjust and fabricate final prototype by November 20

Sensor

- Team Members: Kiley and Quinton
- 3-D print the sensor by November 2
- Fabricate a model that can allow for accurate testing by November 13

**Conclusions/action items:**

Execute and adjust this plan as needed.



## 10/18/20 Fabrication Planning

---

Emily Johnson - Oct 27, 2020, 4:49 PM CDT

**Title:** Fabrication & Materials Planning

**Date:** 10/18/20

**Content by:** Cassidy Geddes

**Present:** Cassidy Geddes and Emily Johnson

**Goals:** Fabricate a rough prototype/ To determine the materials we need for the chest straps and the Straps sensor holder shoe design.

**Content:**

Fabricated a rough first prototype of the straps design with a long exercise band, a cardboard box that is approximately the size of the sensor, and a shoelace. Two pictures of the prototype from various angles are below.





Materials we need:

- spandex for sensor holder part of chest band
  - see image below to see design inspiration.
- Side buckles and strap adjusters
- elastic strap (1.5 in)
- hooks/clip to put on sensor to keep top strap in place
- thin straps for top of sensor (need to be able to fit through shoelace hole)

- better elastic band

**Conclusions/action items:**

Start fabrication of the second prototype of the straps design and the first of the chest band once we get the materials needed ordered. Changed to the prototype with include a loop band for tighter placement of the sensor and cutting of the band to minimize the amount of material beneath the show.

---

CASSIDY Geddes - Oct 25, 2020, 1:58 PM CDT



**IMG\_0099.HEIC(2.7 MB) - download** Arm band design that could be used for inspiration when designing the pocket to hold the sensor for the chest band.



## 10/27/20 Fabrication of Chest Holder and Straps Shoe Design

CASSIDY Geddes - Oct 27, 2020, 10:53 PM CDT

**Title:** Fabrication of Chest Holder and Straps Shoe Design

**Date:** October 27, 2020

**Content by:** Emily Johnson

**Present:** Emily Johnson and Cassie Geddes

**Goals:** To fabricate a rough second prototype of the strap shoe design and to begin fabrication of the chest holder design

**Content:**

The initial loop for the chest sensor was put together without the pocket. It has et to be sewn and for now is a loop with two strap adjusters and a buckle with clasps holding it together. The overall length of the holder may need to be shortened; although that will be easy to do if desired. The shortest length fit the smallest person on the team and the longest is substantially longer than what an average adult would be,

The picture below is the second prototype of the strap shoe design. The band is a loop and has been cut to better fit the overall shape of a running shoe. On the "sensor" (again a cardboard approximate) is a clasp for the thinner straps to connect to the sensor.



**Conclusions/action items:**

For the chest holder, we need to sew the edges of the strap down and make the pocket. Once the team members get the 3-D printed sensors down initial testing can be done.

For the strap shoe design, we need to research more materials for the thinner straps in order to secure it more. We discussed adding a velcro component to it but need to research how that can be done with the materials we currently have. If it cannot then we need to order new materials and go from there. In terms of the placement of the clasp, it needs to be lower on the sensor so that it can provide better stabilization in the vertical direction and so it has less of a chance of riding up and rubbing against the runner ankle. Finally, we want to add size specific pocket for the sensor to sit in on the heel. Testing will begin after these improvements have been made.



## 11/9/20 Fabrication of Third Straps Prototype

Emily Johnson - Dec 09, 2020, 10:14 AM CST

**Title:** Fabrication of 3rd Straps Prototype

**Date:** November 9, 2020

**Content by:** Emily Johnson

**Present:** Emily and Cassie

**Goals:** Fabricate another prototype of the straps design using feedback from show and tell and from previous prototype.

**Content:**

For this prototype, we cut the band that goes beneath thinner as to have less of an impact on the runner. We also cut the strap on top as to make it adjustable (we do not have velcro yet so a knot was used instead). We also moved the hole for the clip down as to provide an upwards force. Below is a picture of the prototype. Began preliminary testing of the design with one minute running tests.







**Conclusions/action items:**

As of now the prototype is functioning, it works well and for the remaining bit of the semester we are going to focus on testing rather than improving. The testing will allow us to determine the most necessary areas of improvement rather than ideas that we have.



## 2020/11/20 First Chest Holder Pocket Prototype

---

QUINTON HENEY - Dec 09, 2020, 2:28 PM CST

**Title:** First Prototype for the Pocket of the Chest holder

**Date:** 11/20/20

**Content by:** Quinton Heney

**Present:**

**Goals:** Create the first pocket prototype to hold the sensor

**Content:**



Figure 1: The first prototype of the pocket for the Chest holder. This prototype was a proof of concept design that was of an incorrect size and was not used in the final prototype.





Figure 2: The inside of the pocket, showing the thread design that was used to create the pocket.

**Conclusions/action items:**

Since the prototype was too small, a new one has to be fabricated, possibly with a more inconspicuous thread color or threading that makes the design look more appealing, and to change the size to fit the sensor more comfortably.



## 2020/12/09 Chest Holder Design Finished

---

QUINTON HENEY - Dec 09, 2020, 11:27 AM CST

*Duplicated from "Quinton Heney">"Design Ideas">"2020/12/02- Chest Holder Design Finished"*

**Title: Completed Chest Strap and Sensor Holder**

**Date:** 12/2/20

**Content by:** Quinton Heney

**Present:**

**Goals:** Finish sewing the sensor holder to the chest strap

**Content:**



Figure 1: The sensor holder "pocket" sewn to the chest strap.  
3: The pocket and sensor side-by-side.

Figure 2: A visualization of how the sensor fits into the pocket.

Figure



Figure 4a, 4b: The full chest holder with attached pocket. Kiley holding the chest holder taut.



Figure 5: The sewing pattern that attached the sensor holder to the chest strap.

**Conclusions/action items:**

Add these to the poster.

Test the strap.

---

QUINTON HENEY - Dec 09, 2020, 11:25 AM CST



chest\_holder\_pocket.jpg(323.9 KB) - [download](#)

---

QUINTON HENEY - Dec 09, 2020, 11:25 AM CST



chest\_holder\_pocket\_visualized.jpg(261.2 KB) - [download](#)

QUINTON HENEY - Dec 09, 2020, 11:25 AM CST



[chest\\_holder\\_pocket\\_and\\_sensor.jpg\(309.3 KB\) - download](#)

QUINTON HENEY - Dec 09, 2020, 11:25 AM CST



[chest\\_holder\\_full.jpg\(88.6 KB\) - download](#)

QUINTON HENEY - Dec 09, 2020, 11:25 AM CST



[chest\\_holder\\_held.jpg\(152.7 KB\) - download](#)



chest\_holder\_sewn\_strap\_back.jpg(341.2 KB) - [download](#)



## 2020/10/29 Clip Holder SolidWorks Design

QUINTON HENEY - Oct 29, 2020, 2:21 PM CDT

*Duplicated from "Quinton Heney">"Design Ideas">"2020/10/15 Clip Holder SolidWorks Design"*

QUINTON HENEY - Oct 29, 2020, 2:16 PM CDT

**Title:** Clip Holder SolidWorks Design

**Date:** 10/15/20

**Content by:** Quinton Heney

**Present:**

**Goals:** Create the SolidWorks design for the clip sensor holder

**Content:**

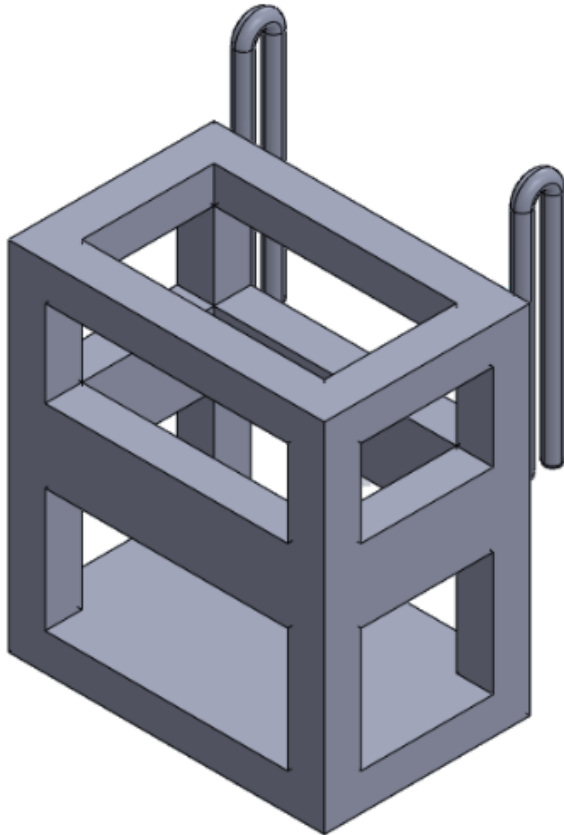

Figure 1: The sensor holder for the "clip" design modeled in SolidWorks. The holder consists of a 3D-printed plastic holder affixed to stainless steel wires that loop over the back of the shoe.

**Conclusions/action items:**

In reality, the holder and stainless steel wire loop would not be oriented parallel to each other due to the shape of the back of the shoe which must be accounted for and I'm afraid that is either very difficult or impossible to do in SolidWorks.



QUINTON HENEY - Oct 29, 2020, 2:16 PM CDT



clip\_holder.SLDPRT(252 KB) - [download](#)

QUINTON HENEY - Oct 29, 2020, 2:16 PM CDT



clip\_holder.SLDDRW(251.7 KB) - [download](#)

QUINTON HENEY - Oct 29, 2020, 2:16 PM CDT

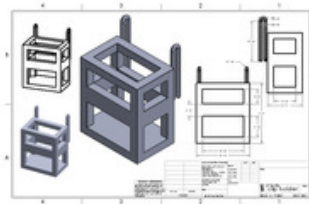

clip\_holder.PNG(37.2 KB) - [download](#)

QUINTON HENEY - Oct 29, 2020, 2:16 PM CDT

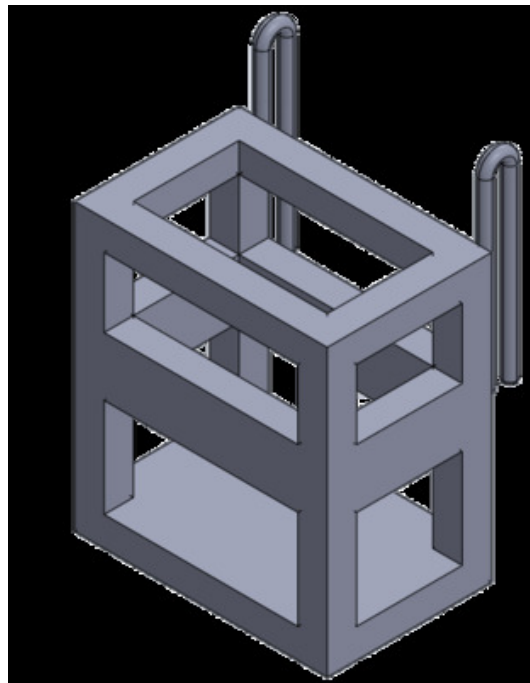

the\_clip\_holder.PNG(53.5 KB) - [download](#)



## Fabrication and Testing of Final Clip Prototypes

IAN SCHIRTZINGER - Dec 09, 2020, 10:37 AM CST

**Title:** Fabricating the final Clip prototypes with sensor holders attached

**Date:** 11/28/20

**Content by:** Ian Schirtzinger

**Goals:** Fabricate sensor holders as well as single continuous wire models for both the copper and wire materials.

**Content:**

Once I had received the 3D printed sensor model from Quinton I was able to begin my design and fabrication of the actual sensor holders themselves (the portion that secures the sensor and attaches to the wire). My initial idea was to fabricate a pouch by sewing fabric together. However, following complications with our family sewing machine, I was forced to pivot to using other materials.

I then decided to explore the possibility of cutting a Ziploc bag into the appropriate dimensions and taping the sides shut. This design was initially attractive because of its simplicity and one side that can open and close allowing for easy application of the sensor. I quickly realized however that this design would not be durable enough nor was it trivial to cut the plastic bag down to the appropriate dimensions.

I decided then to aim to create some sort of pouch with an extended tongue as seen in the drawing below.

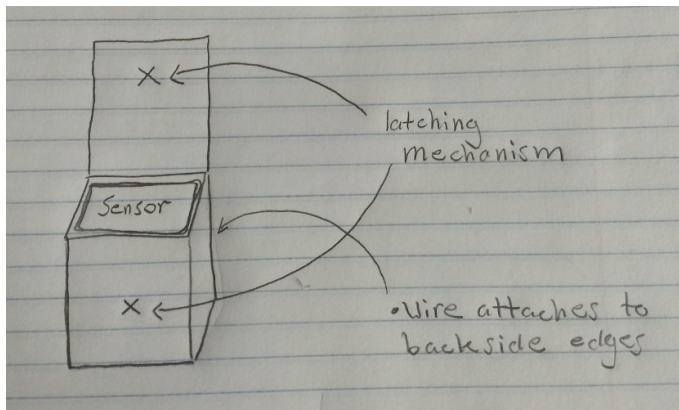

The materials I chose to use were good old fashioned duct tape and polyester from a cinch workout bag. The duct tape proved to be a more simplistic fabrication process than the polyester. For the fabrication of the duct tape model, popsicle sticks were inserted into its sides to add stability, and then duct tape was wrapped around creating a rectangular shape. The tongue was made of a piece of duct tape folded on itself to take away its sticky properties, this bottom half of it was then wrapped up with the rest of the base of the design. This sensor holder fit in well, the only issue being that it was sometimes difficult to remove because of the friction of the outer side of the duct tape. The polyester was cut away from a cinch bag in two pieces. One piece had a longer side (includes the tongue) and the other piece was cut just so that it could be adhered to the base of the first piece, creating a pouch for the sensor holder to slide into. In my first attempt to make this design I tried using heat tape to create a secure seal, however, this method was not strong enough. I decided to try super glue next which did a much better job of securing the edges of the design. At this point, I noticed that although the polyester pouch was able to secure the sensor, its design was a bit too flimsy. To fix this issue I inserted a plastic backing into the pouch so that the sensor would be up against a rigid surface. This was a success however it did slightly compromise the design by making it a much tighter fit and thus difficult to apply and remove the sensor. Images for both of these completed designs are below. You can see that I added velcro as the key mechanism for securing the tongue over the sensor and onto the front side of the pouch.

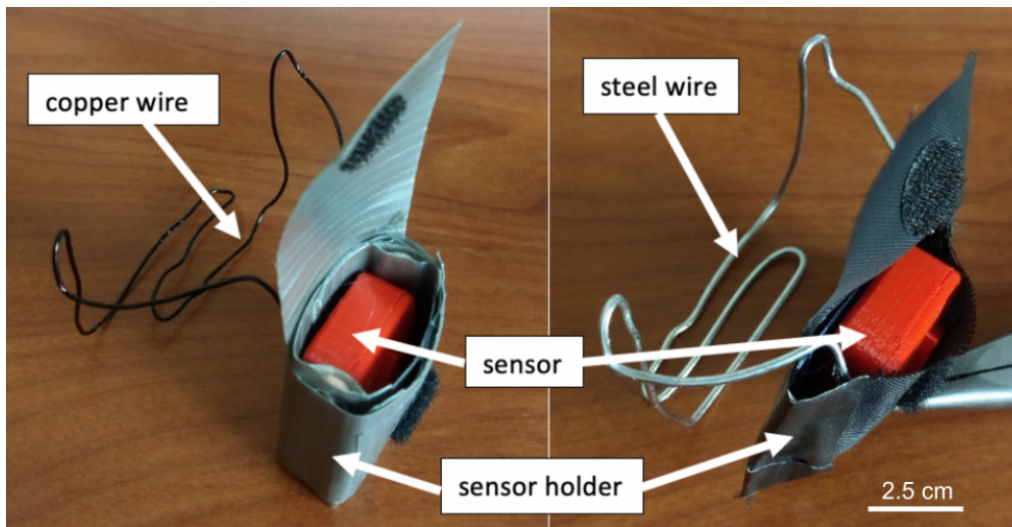

I went on a roughly 3 mile run with both of these prototypes inserted in my shoes to test for their durability and comfort. Both designs maintained their structure throughout and held the 3D printed sensor within its pouch, giving me confidence that these designs are relatively stable. The copper wire model was very comfortable, I could hardly even feel it when running straight and only felt it sometimes when turning. The steel wire model was less comfortable however I was never in any pain. I would rate the two models as follows as far as comfort:

Copper wire model: 9/10

Steel wire model: 7.5/10

An image of the two models inserted in shoes is shown below.



#### Conclusions/action items:

These final designs came together very nicely and functioned well over the course of a three-mile run. Slight alterations will be made in the future to maximize the success of this design. This includes searching for an additional wire material that may be a blend of the copper and steel ones we already have, this material would ideally provide better mechanical properties than copper wire without sacrificing comfort. Additionally, I would like to sew together a sensor holder in the future which includes support material for rigidity and is cut to an optimal fit.



## 2020/10/29 Delsys Trigno Sensor

QUINTON HENEY - Oct 29, 2020, 2:15 PM CDT

*Duplicated from "Quinton Heney">"Design Ideas">"2020/10/29 Delsys Trigno Sensor"*

QUINTON HENEY - Oct 29, 2020, 2:14 PM CDT

**Title:** Delsys Trigno Sensor

**Date:** 10/29/20

**Content by:** Quinton Heney (Staci Quam)

**Present:**

**Goals:** Upload the CAD files of the Delsys Trigno Sensor

**Content:**

Included are .stp and .sldprt files sent by Staci Quam and Johnson Health Tech to help us 3D print a model to practice our designs with.

After running an import diagnostic, SolidWorks found 326 "faulty faces." This seems bad, but the problem message is only that "[the bodies] cannot be modified. The owning feature must be unlinked..."

**Conclusions/action items:**

Figure out if the error given by the diagnostic run will prevent or hamper 3D printing. If things can be fixed or are fine, we can go ahead and 3D print.

QUINTON HENEY - Oct 29, 2020, 2:14 PM CDT



Classic\_Trigno\_Enclosure.SLDPRT(2.1 MB) - [download](#)

QUINTON HENEY - Oct 29, 2020, 2:14 PM CDT



Classic\_Trigno\_Enclosure.stp(2.8 MB) - [download](#)



## 2020/11/18-Circuit Creation and Testing

Kiley Smith - Dec 08, 2020, 9:21 PM CST

**Title: Circuit Creation and Testing****Date:** Nov 18, 2020**Content by:** Kiley Smith**Goals:** To assemble the circuits and to figure out which sensor to use in future tests of our product.**Content:**

Yesterday I went into the Makerspace to solder together the sensors and the circuit board. The first sensor that I tested was the LSM303AGR accelerometer. The instructions for use and assembly available online were only for if you had purchased the STEMMA wires as well. After searching for instructions on how to connect the different pins and read the data with no luck, I switched to the LSM6DS33 sensor.

That sensor was much easier to use and assemble. I only needed to connect the SCL and SDA pins to the matching ones on the microcontroller and the code was up and running. Below is the resulting graph of the accelerometer data. When I first tested the circuit, the Z component had a resting acceleration of +10m/s. I fixed that temporarily by subtracting 10 from the read data. In the graph below I began by moving the sensor at random but then at around 200ms I started to try and mimic the movement of a foot while running. The data looked as expected so I believe that it is a viable option for testing our sensor holders.

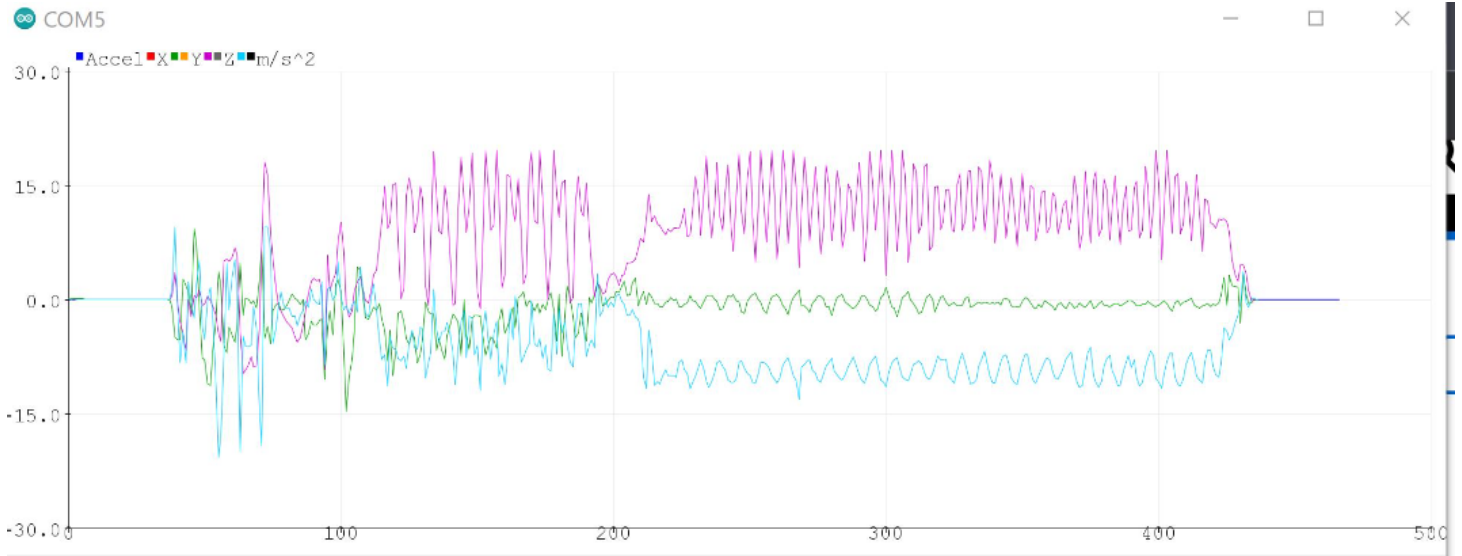
**Conclusions/action items:**

Try to figure out how to program the microcontroller to communicate via Bluetooth and to find a battery to power it.



## 2020/12/09-Updated Testing protocols

---

Kiley Smith - Dec 09, 2020, 11:01 AM CST

**Title: Updated Testing Protocols**

**Date:** 12/09/2020

**Content by:** Kiley Smith

**Goals:** To Create a better more specific testing protocol to ensure the most reliable tests.

**Content:**

*Shoe Sensor Holders:*

1. Attach three markers to the shoe that is going to be tracked. If you are filming from the back only two are needed. Place one marker on the center of the sensor holder and the other on the shoe directly below it. For the side view place one marker on the center of the sensor holder, one horizontally from that in front of the ankle, and one towards the back of the shoe on the rubber sidewall.
2. Ensure that all markers are visible to the camera.
3. Measure the length of your shoe to use as a reference when uploading the data to Kinovea.
4. If the test is not being conducted on a treadmill, create an X or marker on the ground so that you are stepping in the same place everytime. This will help to eliminate error due to perspective change.
5. Begin recording and run for 30 seconds.
6. Continue to run in place for two minutes or run outside for two minutes.
7. Without touching the sensors record yourself running in place for another 30 seconds.
8. Repeat trial for each sensor five times per user.
9. Upload the videos through Kinovea.
10. Select an Origin and place the reference measurement of the shoe.
11. Right click to place a trace on each marker
12. Click through frame by frame to ensure that the traces stay centered and adjust as needed.
13. Export the data as an excel file and upload the data to matlab to calculate the movement.

*Chest Strap*

1. Put chest strap on so it is tight but still comfortable. It should be at the base of your sternum
2. Place marker on the center of the sensor holder and one directly above it at the top of the sternum.
3. Put a mark on the ground to ensure that the perspective doesn't change.
4. Measure your shoulder with as a reference length.
5. Repeat steps 5-13 as with the shoe sensor holders.

**Conclusions/action items:**

These testing protocols should help eliminate the error experienced in the first round of testing that resulted from the test subject moving and from not being able to triangulate the



## 2020/11/21-Outdated Testing protocols

---

Kiley Smith - Dec 09, 2020, 11:34 AM CST

**Title:** Testing Protocols

**Date:** 11/21/2020

**Content by:** Kiley Smith

**Goals:** To Create testing protocols for our groupmates to follow

**Content:**

*Shoe Sensor Holders:*

1. Attach three markers to the shoe that is going to be tracked. If you are filming from the back place one marker on the center of the sensor holder and the other on the shoe directly above it and one to the side on the rubber. For the side view place one marker on the center of the sensor holder, one horizontally from that in below the ankle, and one towards the back of the shoe on the rubber sidewall.
2. Ensure that all markers are visible to the camera.
3. Measure the length of your shoe to use as a reference when uploading the data to Kinovea.
4. Begin recording and run for 15 seconds.
5. Repeat trial for each sensor twice per user.
6. Upload the videos through Kinovea.
7. Select an Origin and place the reference measurement of the shoe.
8. Right click to place a trace on each marker
9. Click through frame by frame to ensure that the traces stay centered and adjust as needed.
10. Export the data as an excel file and upload the data to matlab to calculate the movement.

*Chest Strap*

1. Put chest strap on so it is tight but still comfortable. It should be at the base of your sternum
2. Place marker on the center of the sensor holder and one directly above it at the top of the sternum.
3. Put a mark on the ground to ensure that the perspective doesn't change.
4. Measure your shoulder with as a reference length.
5. Repeat steps 5-13 as with the shoe sensor holders.

**Conclusions/action items:**

These testing protocols may need to be adjusted based on results from our first round of testing.



## 2020/11/9 First Phase of Testing for Straps Design

Emily Johnson - Dec 09, 2020, 1:48 AM CST

**Title:** The First Testing of the Straps Prototype

**Date:** November 9, 2020

**Content by:** Emily Johnson

**Present:** Emily and Cassie

**Goals:** To determine if the updates to the prototype were beneficial

**Content:**

The sensor position was marked on the shoes then the subject (emily) ran one minute then the new position of the sensor on the heel was marked. The change in the distance was then measured with a ruler. Trials 1 to 3 were normal but trial 4 did not have the upper shoe lace strap- this was a quick test to make sure that both of them worked. Emily also made note of the comfort. She felt that they were similar but the additional removal of the material for the second prototype allowed for less discomfort and it had less movement / rolling of the material.

The set-up of the testing procedure



the data in a table-

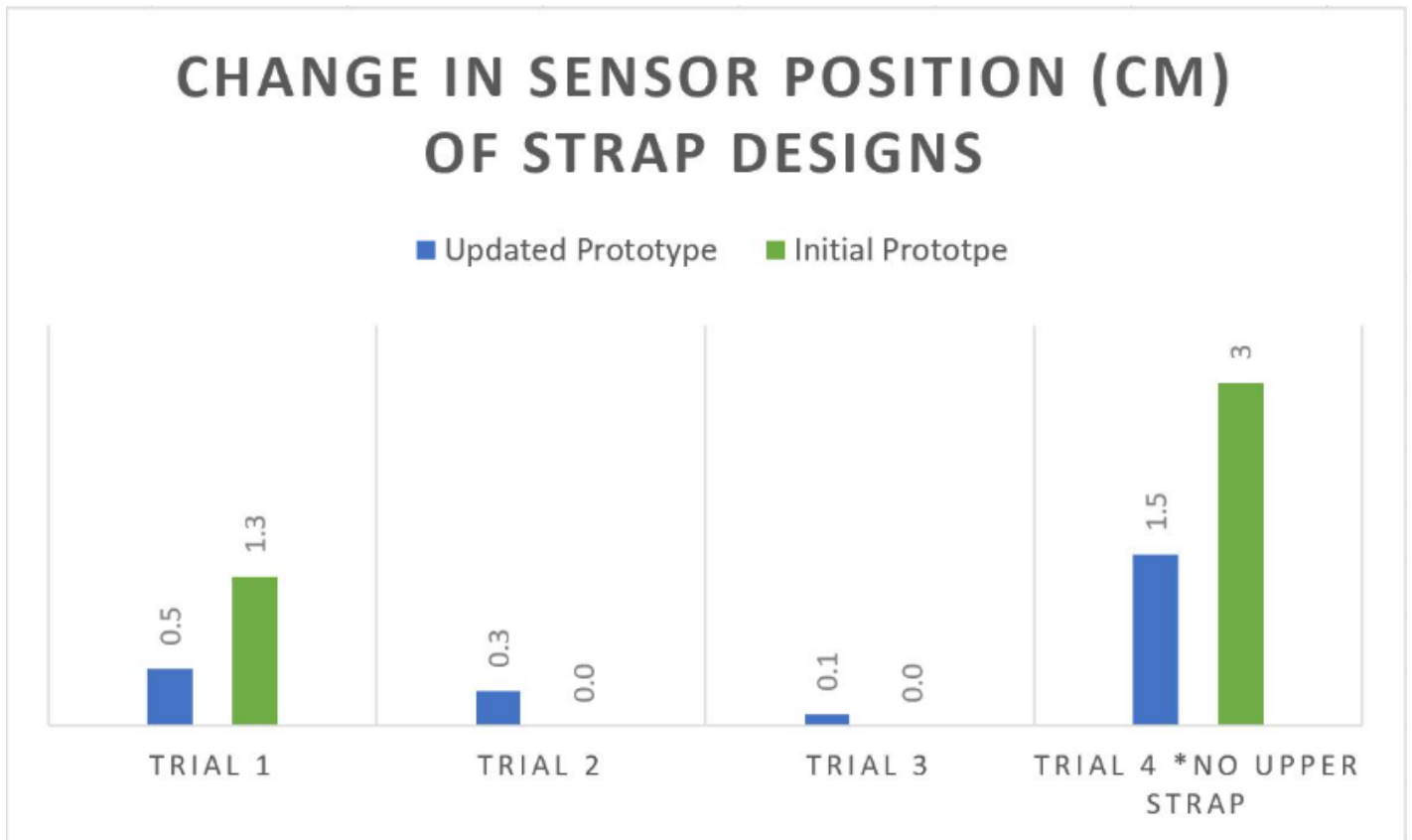

**Conclusions/action items:**

Analyze the data and put the information in the final presentation and report



## 2020/12/02 Kinovea Straps Testing

---

Emily Johnson - Dec 09, 2020, 11:19 AM CST

**Title:** Second Phase of Testing for the Straps Design- Kinovea

**Date:** December 1, 2020

**Content by:** Emily Johnson

**Present:** NA

**Goals:** Figure out the Kinovea Software

**Content:**

November 30

Videotaped running in place with markers (back and side view) to track in kinovea software. Ran a short distance then did another videotape for each perspective. Completed this cycle three times.

Attempted to track the movement of the markers in Kinovea but ran into technical difficulties. Unsure what the problem is and if it was human error, software error, or lack of knowledge on the software.



December 1

Met with the group and kiley (has the most knowledge of the software) told me it was possibly because my video was too far away. The software is basic. Discussed other options if I did not figure it out

December 2

Re-shot the videos. This time I just ran in place for approximately 30 seconds. Ran the video through Kinovea (it worked!) and gave the raw data to kiley.



### December 3

Kiley let me know that I did not do the software correctly. I moved the positioning too much when I was going frame-by-frame and I did not set a distance for perspective so the data was not in centimeters, Re- shot the videos with high socks on to minimize manual corrections (sometimes the tracker would jump to my skin because of the pigment) and with bigger green circles for the same issue. Ran through Kinovea and gave data to kiley. Ran in the sensor to determine if there was any drastic issues with comfort. Switched shoes to my flat-bottomed lifting shoes to determine if the straps would stay on. Ran again a short distance to determine comfort and how it stayed on. Seemed to hold up. Shot videos for Kinovea, went through it in the software (minimal corrections-- finally) and sent the data to Kiley.



**Conclusions/action items:**

Analyze the data that kiley produces and draw statistical conclusions based on it.



## 2020/12/03-Clip Kinovea

Kiley Smith - Dec 09, 2020, 11:13 AM CST

**Title:** Clip Kinovea

**Date:** Dec 03, 2020

**Content by:** Kiley Smith

**Goals:** To add the traces to Ian's testing videos for the copper and steel wire.

**Content:**

Ian's videos were very difficult to process due to the low camera quality or poor lighting. There are not enough frames per second to get an accurate trace on every dot. Many frames had to be adjusted and the trace estimated. With some of the views from the back, the shoe marker went out of the field of view.



**Conclusions/action items:**

# 2020/12/09-Design testing Results

Kiley Smith - Dec 09, 2020, 11:28 AM CST

**Title:** Design Testing Results

**Date:** Analysis performed 12/2/2020 and 12/3/2020

**Content by:** Kiley Smith

**Goals:** To analyze the data collected from the Kinovea traced videos.

**Content:**

After the data had been collected in Kinovea, it exported excel files storing the X and Y coordinates and time of the markers. This data was imported into MATLAB to be graphed. First the initial distance between the two markers was measured using the distance formula. This served as our reference for if movement had occurred. If there was movement, it would show up as an increase or decrease in this length. Then the initial distance between the X and Y coordinates was recorded. These values were expected to change more since the foot rotates. They were more to be used to determine what type of movement is occurring if there was a significant change in distance between the two sensors.

|               | Back View                     |                            |                            | Side View                     |                            |                            | Frames of Back View | Distance/Frame of Back | Frames of Side | Distance / Frame of Side View |
|---------------|-------------------------------|----------------------------|----------------------------|-------------------------------|----------------------------|----------------------------|---------------------|------------------------|----------------|-------------------------------|
|               | Change in total Distance (cm) | Change in X Direction (cm) | Change in Y Direction (cm) | Change in total Distance (cm) | Change in X Direction (cm) | Change in Y Direction (cm) |                     |                        |                |                               |
| Copper Wire 1 | 1.9686 (+/-1.497)             | 0.5888 (+/-0.5404)         | 1.9686 (+/-1.1497)         | 0.1966 (0.4963)               | 0.9068 (0.5981)            | 0.8853 (0.6878)            | 309                 | 2.138                  | 456            | 0.37                          |
| Copper Wire 2 | 2.1447 (+/-1.1497)            | 0.8286 (+/-0.5461)         | 2.3575 (+/-1.1497)         | 0.2894 (0.5329)               | 0.2894 (0.6341)            | 0.4076 (0.6898)            | 332                 | 1.973                  | 332            | 0.4816                        |
| Steel Wire 1  | 1.6505 (+/-0.9517)            | 0.6512 (+/-0.5676)         | 1.6505 (+/-0.9517)         | 0.0635 (0.6774)               | 1.2719 (0.6251)            | 0.4244 (0.7574)            | 329                 | 1.6575                 | 252            | 0.5218                        |
| Steel Wire 2  | 2.649 (+/-1.1278)             | 1.1407 (+/-0.5971)         | 2.6490 (+/-1.1278)         | 0.2171 (0.4882)               | 1.1107 (0.6878)            | 0.641 (0.5722)             | 358                 | 2.649                  | 359            | 0.4254                        |
| Straps 1      | 0.6735 (+/-0.728)             | 1.1824 (+/-0.7963)         | 0.9827 (+/-0.5353)         | 0.3784 (0.4716)               | 1.1824 (1.8925)            | 0.4067 (1.55)              | 466                 | 0.8042                 | 438            | 0.4588                        |
| Straps 2      | 1.3005 (+/-0.5807)            | 1.0585 (+/-0.5108)         | 0.8352 (+/-0.5370)         | 2.8002 (1.4191)               | 0.3037 (2.1708)            | 4.6431 (2.9013)            | 461                 | 1.3185                 | 320            | 2.81219                       |

Above is our raw analysis data without any filtering applied. As you can see the change in distance from behind is much higher than the side view but this is due to the change in perspective when the foot rotates.

| CHEST | change in total distance | change in x direction | Change in y direction |
|-------|--------------------------|-----------------------|-----------------------|
| Trial |                          |                       |                       |
| 1     | 0.0173 (0.8032)          | 0.0338 (0.7949)       | 0.0559 (0.6963)       |
| 2     | 0.823 (0.6312)           | 0.8186 (0.6298)       | 0.047 (0.4825)        |

The Chest Strap Moved very little throughout the trials. The first trial was more successful with less overall movement but that could be due to me staying in place better. Because of the placement of the dots in a straight line, the change in X and Y directions are a very good representation of the actual movement.

**Conclusions/action items:**

We are unable to make any definitive conclusions at this time due to the possible errors in testing and low sample size. Going forward we will use better cameras and have more trials.

Kiley Smith - Dec 09, 2020, 10:35 AM CST

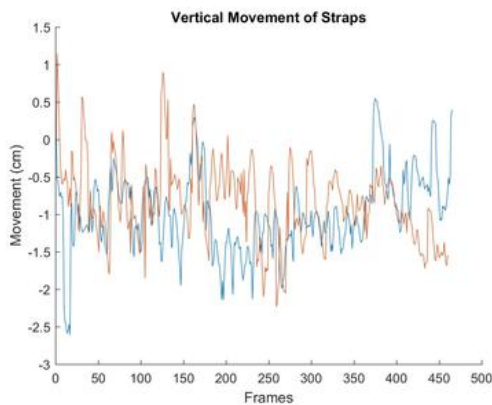

3.jpg(105.4 KB) - download

Kiley Smith - Dec 09, 2020, 10:35 AM CST

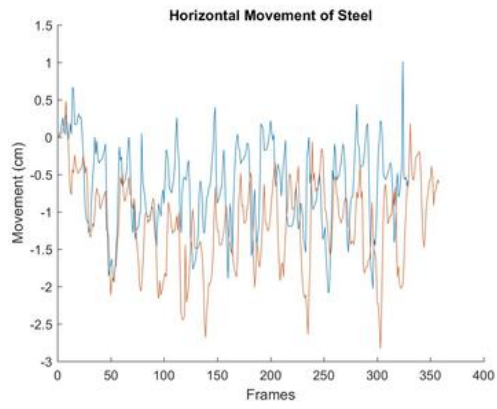

4.jpg(105.9 KB) - [download](#)

Kiley Smith - Dec 09, 2020, 10:35 AM CST

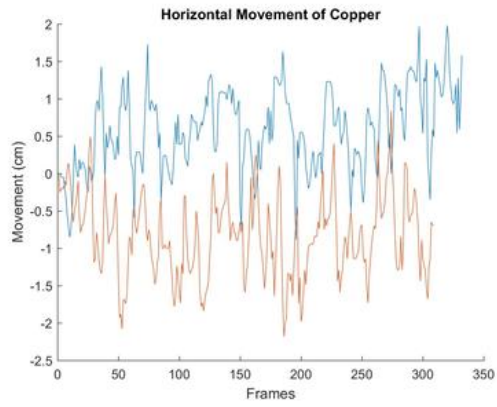

5.jpg(112.1 KB) - [download](#)

Kiley Smith - Dec 09, 2020, 10:35 AM CST

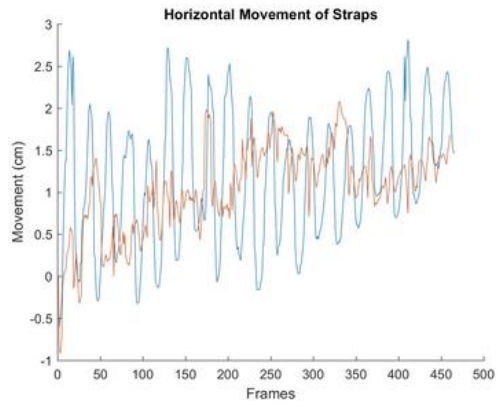

6.jpg(113.7 KB) - [download](#)

Kiley Smith - Dec 09, 2020, 10:35 AM CST

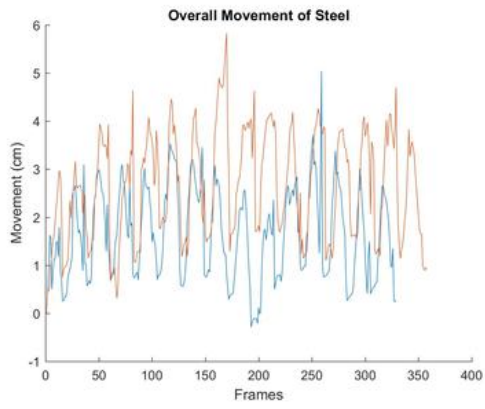

7.jpg(105.3 KB) - [download](#)

Kiley Smith - Dec 09, 2020, 10:35 AM CST

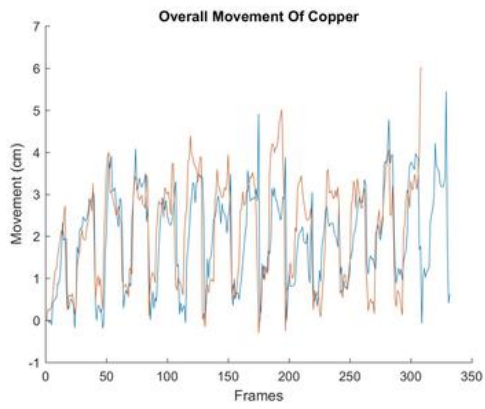

8.jpg(101.2 KB) - [download](#)

Kiley Smith - Dec 09, 2020, 10:35 AM CST

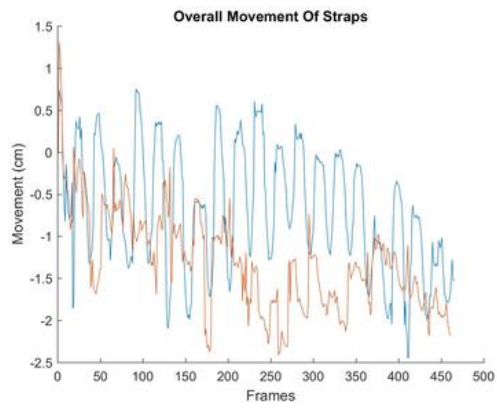

9.jpg(109.9 KB) - [download](#)



Kiley Smith - Dec 09, 2020, 10:35 AM CST

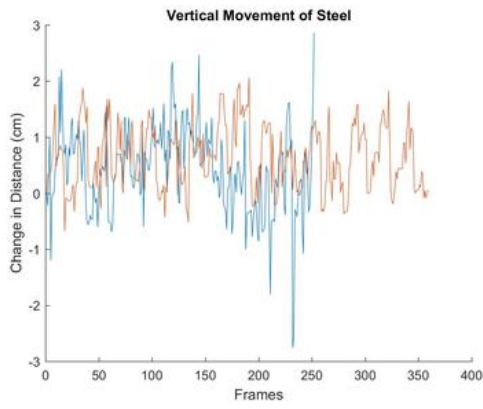

a.jpg(99.8 KB) - download

Kiley Smith - Dec 09, 2020, 10:35 AM CST

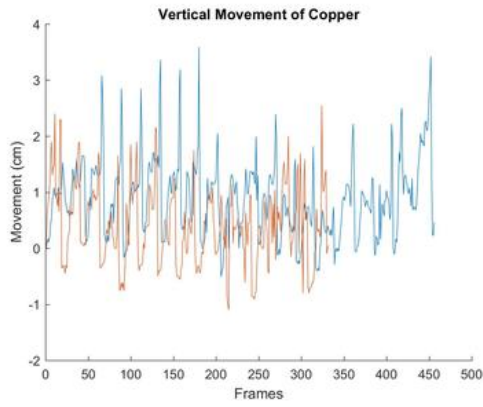

b.jpg(108.3 KB) - download

Kiley Smith - Dec 09, 2020, 10:35 AM CST

```

%% bme 400 Movement Analysis
close all;
close all;
file = input('File: ');
fid = fopen(file);
% Movement Analysis
sensor_x = data(:, 2);
sensor_y = data(:, 3);
sensor_z = data(:, 4);
time = time(:, 5);

% Plot
plot(sensor_x, 'b');
plot(sensor_y, 'o');
plot(sensor_z, 'r');
axis([0 400 -3 3]);
legend('x', 'y', 'z');
title('Vertical Movement of Steel');

% Movement Analysis
sensor_x = data(:, 2);
sensor_y = data(:, 3);
sensor_z = data(:, 4);
time = time(:, 5);

% Plot
plot(sensor_x, 'b');
plot(sensor_y, 'o');
plot(sensor_z, 'r');
axis([0 500 -2 4]);
legend('x', 'y', 'z');
title('Vertical Movement of Copper');

```

bme400.m(6.3 KB) - download

Kiley Smith - Dec 09, 2020, 10:35 AM CST

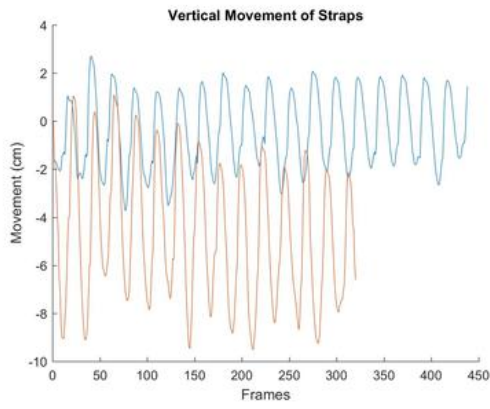

c.jpg(112.2 KB) - download

Kiley Smith - Dec 09, 2020, 10:35 AM CST

```

bodyL_x = varargin{1};
bodyL_y = varargin{2};
strutL_x = varargin{3};
strutL_y = varargin{4};
bodyR_x = varargin{5};
bodyR_y = varargin{6};
strutR_x = varargin{7};
strutR_y = varargin{8};

#strutL_x = bodyL_x - strutL_x;
#strutL_y = bodyL_y - strutL_y;
#strutR_x = bodyR_x - strutR_x;
#strutR_y = bodyR_y - strutR_y;
strutL_x = #strutL_x(1);
strutL_y = #strutL_x(2);
strutR_x = #strutR_x(1);
strutR_y = #strutR_x(2);

#strutVecL = sqrt(#strutL_x.^2 + #strutL_y.^2);
#strutVecR = sqrt(#strutR_x.^2 + #strutR_y.^2);
#normVecL = #strutVecL - #strutVecL(1);
#normVecR = #strutVecR - #strutVecR(1);
x_normL = #strutL_x - #strutL_x;
y_normL = #strutL_y - #strutL_y;
x_normR = #strutR_x - #strutR_x;
y_normR = #strutR_y - #strutR_y;

#plot on;
plot(bodyVecL(1));
plot(bodyVecL(2));
xlabel('Strut L');
ylabel('NormVecL (cm)');
title('Strut L Movement');
%
%
plot(bodyVecR(1));
plot(bodyVecR(2));
xlabel('Strut R');
ylabel('NormVecR (cm)');
title('Strut R Movement');
%
%
plot(bodyVecL(1:200));
plot(bodyVecL(1:200));
%
%

```

chest.m(878 Bytes) - download

Kiley Smith - Dec 09, 2020, 10:35 AM CST

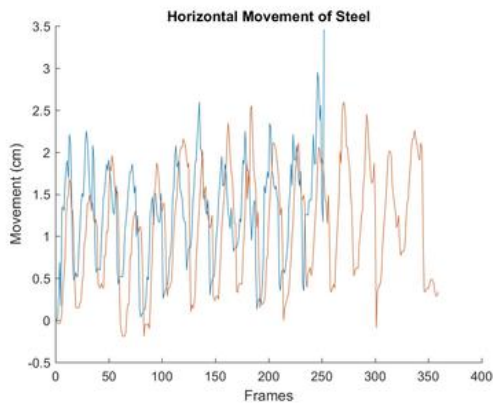

d.jpg(106.3 KB) - download

Kiley Smith - Dec 09, 2020, 10:35 AM CST

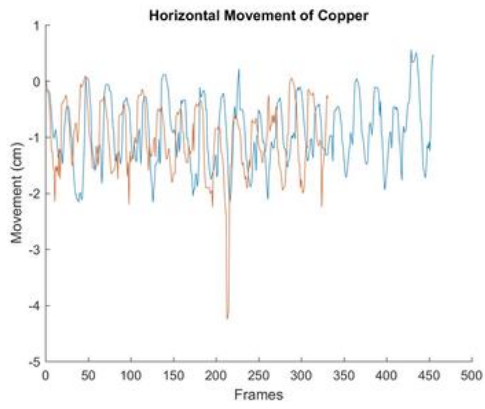

[e.jpg\(94.6 KB\) - download](#)

Kiley Smith - Dec 09, 2020, 10:35 AM CST

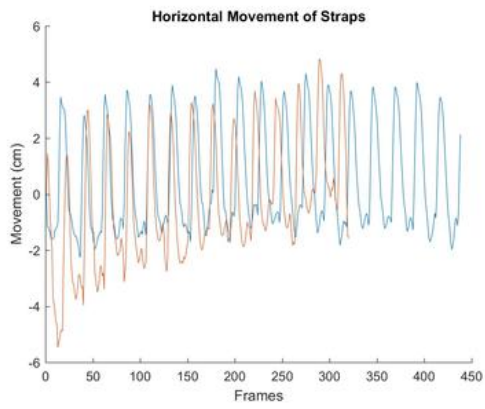

[f.jpg\(112.8 KB\) - download](#)

Kiley Smith - Dec 09, 2020, 10:35 AM CST

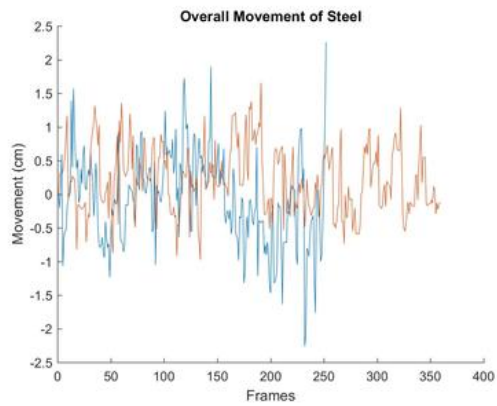

[g.jpg\(104.9 KB\) - download](#)

Kiley Smith - Dec 09, 2020, 10:35 AM CST

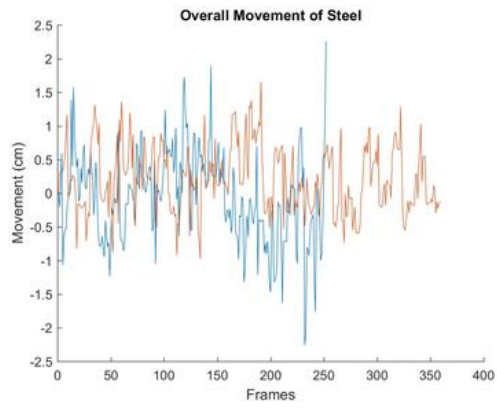

[h.jpg\(104.9 KB\) - download](#)

Kiley Smith - Dec 09, 2020, 10:35 AM CST

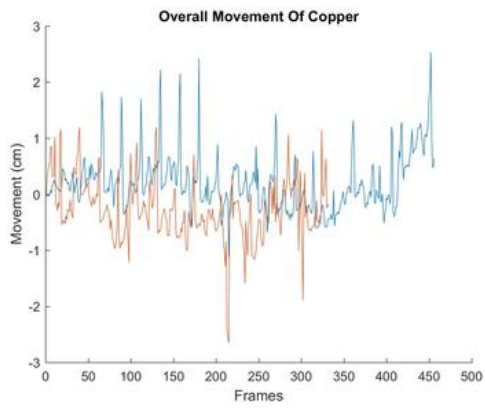

[i.jpg\(95.1 KB\) - download](#)

Kiley Smith - Dec 09, 2020, 10:35 AM CST

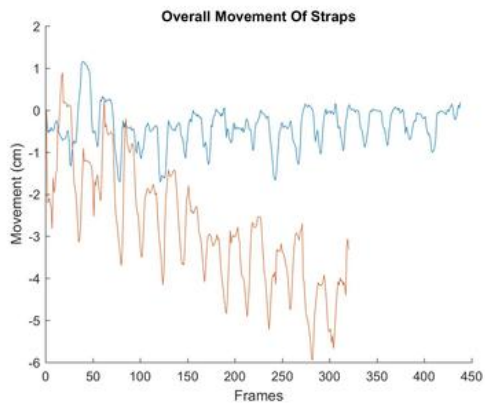

[j.jpg\(87.1 KB\) - download](#)

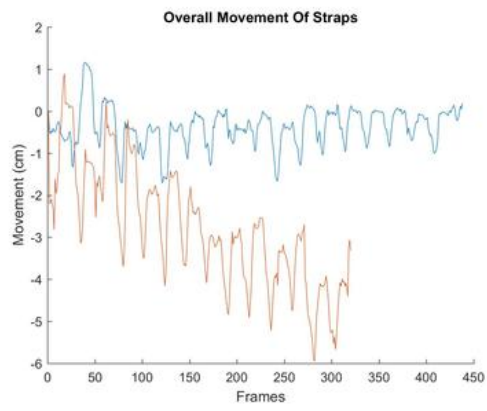

k.jpg(87.1 KB) - [download](#)



## 2020/11/05 .stl File for 3D Printing

---

QUINTON HENEY - Nov 05, 2020, 3:25 PM CST

**Title:** .stl File of the Sensor for 3D Printing

**Date:** 11/5/20

**Content by:** Quinton Heney

**Present:**

**Goals:** Convert the .sldprt file to a .stl file for Makerspace 3D printing

**Content:**

Posted in attachment underneath entry

**Conclusions/action items:**

Meet with the Makerspace people virtually tomorrow and get printing ready.

---

QUINTON HENEY - Nov 05, 2020, 3:25 PM CST



[jht\\_sensor\\_holder\\_3D\\_print\\_Quinton\\_Heney\\_11\\_06\\_2020.STL\(2.4 MB\) - download](#)



## 2020 - Team Meeting

---

Emily Johnson - Dec 09, 2020, 10:59 AM CST

**Title:** Minimal Team Meeting

**Date:** Fall 2020

**Content by:** Emily Johnson

**Present:**

**Goals:** Explain the lack of definitive meetings

**Content:**

Without the ability to meet in-person as we once were, our communications was only virtual. The format we chose to pursue allowed us to not meet as regularly as it would with other semesters. We communicated in text regularly with updates on our piece of the project. Only when we felt it necessary did we set up a time to discuss progress in a video chat. The advisor meetings were also used to update each other. Towards the end of the semester, the frequency of meetings increased as the testing was discussed.

**Conclusions/action items:**

Reflect back on if this was beneficial and how we want to proceed next semester



## 2020/09/15-Team Meeting

---

Kiley Smith - Dec 09, 2020, 12:19 AM CST

**Title:** Team Meeting

**Date:** Sept 15, 2020

**Content by:** Kiley Smith

**Present:** All

**Goals:** Determine Plan for the rest of the week

**Content:**

- Met to discuss project going forward
- Right now the project is mostly design focused and the data processing will be after initial designs are created
- Each of us will create at least one design.
- Kiley and Ian will create a variation of the clip design
- Emily will create a strap design.

**Conclusions/action items:**

Cassie will email the client to follow up on the materials that we discussed previously last week. Each of us will create one design for us to discuss and share on Friday. These designs will be compared and combined.





## 2020/10/16 - Team Meeting

---

CASSIDY Geddes - Dec 09, 2020, 11:01 AM CST

**Title:** Design Check in

**Date:** 10/16/20

**Content by:** Cassie Geddes

**Present:** All

**Goals:** To figure out where everyone is in the design process and determine our goals for the next week.

**Content:**

- we have solid prototype ideas for each design and have done a lot of research on what type of materials we want to use.
- Discussed the different materials we found
- Exercise band made from latex/elastic might be better than fabric because it provides more grip

**Conclusions/action items:**

Make sure to get all of the materials we need ordered in the next week so that we can start fabricating. Also make sure IMU/microcontroller is ordered so that code can be tested for it.



## 2020/11/10 - Team Meeting

---

Emily Johnson - Dec 09, 2020, 12:25 PM CST

**Title:** Team meeting to check in on progress

**Date:** 11/10/20

**Content by:** Cassidy Geddes

**Present:** All

**Goals:** To update each other on our progress so we can plan out our next steps in our design process.

**Content:**

- Cassie and Emily finished the second prototype of the straps design and performed testing. We found that the updated prototype has a little less slipping of the sensor, but both of them have very little movement.
- We could use rubber cement for attaching a little pocket made of latex to the latex band to hold the sensor even more secure.
- Quinton is going to 3D print the sensor by the end of this week.
- We discussed other material options for the clip design so that there is less movement of the sensor. Ian suggested steel wire since it is more rigid and will deform less during applied force.
- We discussed if, with more research, any of the ideas from Show and Tell were helpful

**Conclusions/action items:**

Keep developing the prototypes for each shoe sensor holder design. We need to get the chest band sewn so that we can start testing it.



## 2020/11/20 - Team Meeting

---

CASSIDY Geddes - Dec 09, 2020, 10:44 AM CST

**Title:** Testing Options Meeting

**Date:** 11/20/20

**Content by:** Cassie Geddes

**Present:** All

**Goals:** Figure out how we want to test each design and how we will be able to use the data that we collect.

**Content:**

- We could use a motion detection program that tracks marks set on the shoe as the user runs. This would allow us to more accurately/uniformly track movement of the sensor during use
- We could also use this for the testing of the chest strap
- The testing that Emily and Cassie did has more room for human error
- Once we get the data we will want to prove that the amount of movement of the sensor is or is not statistically significant. Could do this with the p-test, t-test or other options

**Conclusions/action items:**

- Figure out which motion detection system we want to use and what coding system we will use to analyze the data. We also need to determine what type of test we want to use on the data to prove its statistical significance. Keep progressing with each design and make sure the chest strap is finished for testing.



## 2020/12/01- Testing Meeting

---

Emily Johnson - Dec 08, 2020, 1:14 PM CST

**Title:** Team Meeting to Discuss Testing Software / Procedure

**Date:** December 1, 2020

**Content by:** Emily Johnson

**Present:** Cassie, Kiley, Quintin (Kiley met with Ian alone later)

**Goals:** Figure out our testing problems / Discuss other options if problems continue

**Content:**

Kinovea Software-

- Emily is having trouble with her videos and tracking the different points
  - Possibly taking videos that are closer so the software will distinguish the points
  - If not there are other options, the same testing that Cassie and Emily did but with more trials
- Straps design needs to be tested with a flat bottom
- Everyone will continue to go through the software with their design then Kiley will run the raw data through MATLAB

**Conclusions/action items:**

Get the testing done as soon as possible so there is time to analyze it prior to the final presentation



## Sept 10- Arch Compression / Recoil while Running

Emily Johnson

**Title:** Active Regulation of Longitudinal Arch Compression and Recoil during Walking and Running

**Date:** September 10, 2020

**Content by:** Emily Johnson

**Goals:** Gain an understanding of the arch movement during running

**Content:**

DOI: 10.1098/rsif.2014.1076

Introduction:

- MTU = Muscle Tendon Units
- Longitudinal arch
  - Structural Integrity
    - stiff enough for forward propulsion
    - flexible enough to combat surface and load changes
  - Loaded = lengthened and lowered (FOOT SPRING MECH)
    - plantar intrinsic foot muscles -> three largest have MTUs spanning LA (stretch during compression)
      - abductor hallucis (AH- red)
      - flexor digitorum brevis (FDB- blue)
      - quadratus plantae (QP- green)
      - Positioning of the MTUs is pictured below

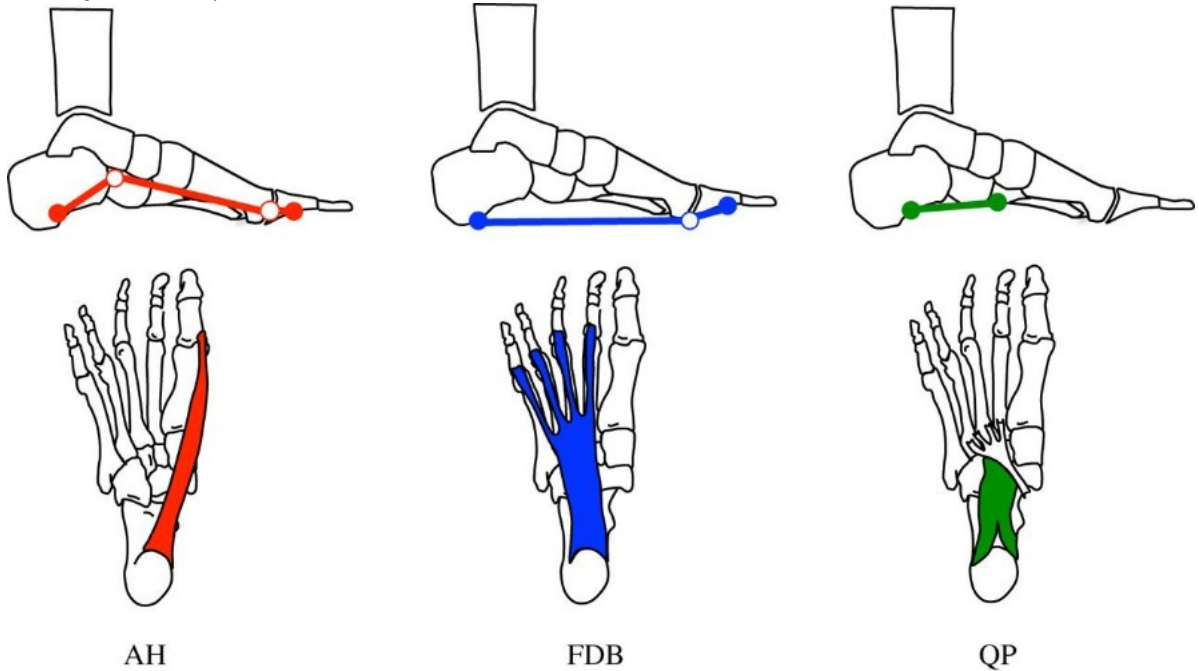

▪ Figure 1: The MTU pathways are on top and the anatomical pathways for each large plantar intrinsic muscle with the filled in circles being the origin and insertion points and the open circles are the tether points.

- Active MTU lengthening from applied external load -> tension
- Active MTU shortening -> mechanical power
- Walking Phase Muscle Activation (magnitude of activation depends on encountered load)
  - Early Stance- activation of the intrinsic foot muscles -> stiffens the LA / contributes to absorbed of power w/i stretched MTU (reduce total load on passive ligamentous structure)
  - Late Stance- deactivation of muscles -> MTUs shorten (the deactivation may contribute to recoiling of elastic parts of MTU)
- HOW GAIT VELOCITY AFFECT THE ARCH?

Secured the electrodes and such with **COHESIVE BANDAGE** (common for AT practices)

Results

- Change of LA angle while running (cyclic)
  - Early Stance- swift increase
  - Late Stance- swift decrease (associated with propulsion)
- Early -> Mid-stance = LA compression / MTUs lengthened w increasing vertical forces
- Mid- -> Late Stance = LA recoil / MTUs shorten rapidly with decreasing vertical forces
- More detailed on each separate MTU is in the paper if needed later

Discussion

- Different LA structures can alter the persons ability to conform to a load
  - Be careful on altering the arch of the runner with the device
- Plantar aponeurosis (PA) (PASSIVE)
  - Early Stance: stretch
  - Late Stance: provides stiffness to LA (thought to be primary component for this)

- stiffness is in prep for propulsion
- limited adaptation ability with changing loads
- The idea that stiffness is COMPLETELY PASSIVE does not account for the adaptability of LA (more stiffness with higher loads w/o more PA tension)

**Conclusions/action items:**

When designing the prototype be sure to account the need for these MTU to lengthen and shorten in order for the longitudinal arch to work properly. Changes in the LA will lead to alterations v recommended. The device needs to be secure enough to hold everything in place but not too tight as to have reproductions.



## Oct 3- Center of Mass During Running

---

Emily Johnson - Oct 03, 2020, 4:03 PM CDT

**Title:** Center of Mass Trajectory During Running

**Date:** October 3, 2020

**Content by:** Emily

**Present:** NA

**Goals:** Learn about the contributions to and the movement of the COM during running to better fabricate a center of mass chest holder.

**Content:**

Source- "Determinants of the Center of Mass Trajectory in Human Walking and Running" Journal of Experimental Biology 1998(<https://jeb-biologists-org.ezproxy.library.wisc.edu/content/201/21/2935.short>)

### Running Compared to Walking

- 35% less foot-ground contact
- 50% greater peak GRF
- Walking = inverted pendulum system
  - Point Mass = Runner's Body Mass
  - Rigid Strut = Legs
- Running = simple spring-mass system
  - Point Mass = Runner's Body Mass
  - Spring = Leg
    - Compresses as foot hits the ground and mass moves downward
    - Max Compression = Middle of stance

### Center of Mass in the Middle of Stance

- Running = Lowest Point
- Walking = Highest Point

### Results

- Running Vertical Displacement
  - Lower Speeds - 0.030 +/- 0.002 m
  - Higher Speeds- 0.050 +/- 0.006
- COM moves 0.041 m downs (first half of running stance phase)
- COM during on running (versus walking) depends on
  - Virtual stance-limb touchdown angle
  - Virtual stance-limb compression

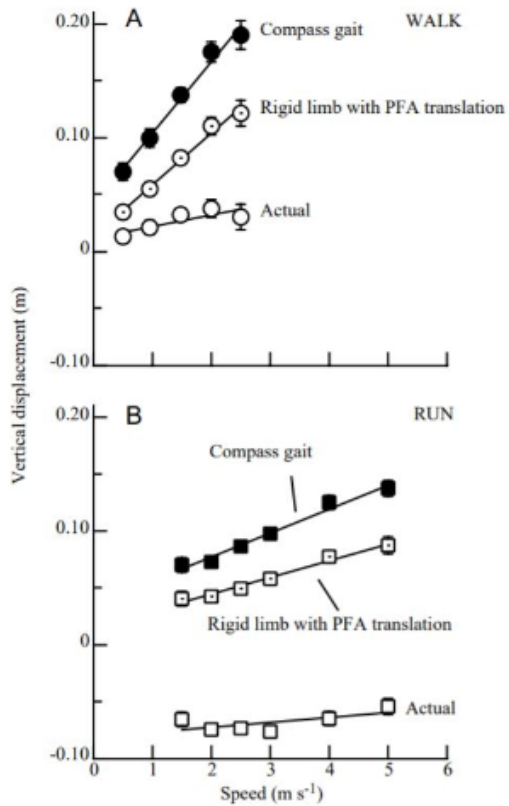

#### Conclusions/action items:

COM during running has very little displacement only 3 to 5 cm. The design needs to stay in the correct position and it is important to understand that there would be movement in the vertical direction due to this COM movement. The securement in this direction is extremely important especially because the horizontal does not have this acceleration aspect. If the design does move with it then the data would not be accurate which is the exact opposite of what is wanted.





## Sept 12- Compression Shoe Attachment

Emily Johnson - Sep 12, 2020, 4:10 PM CDT

**Title:** Running Shoe having a Progressive Compression Attachment

**Date:** September 12, 2020

**Content by:** Emily Johnson

**Goals:** Gain an understanding about the features of the attachment and develop ideas from them.

**Content:**

Patent- US20130008052A1

Progressive Compression = applying the desired compression throughout the stride

if too soft...

1. instability
2. bad body posture
3. negate progressive compression from rapid collapse

Components-

1. Cushioning Feature

1. First Layer
2. Securing Feature

2. Resilient / Traction Feature

1. Second Layer

3. Securing Feature

1. Cannot detach while in use

Design-

1. Cushioning (not too important as we are not trying to improve comfort)

1. Desired Material Properties

1.  $0.6 \text{ MPa} < \text{Elastic Modulus} < 1 \text{ MPa}$
2.  $0.2 < \text{Compression Deflection} < 0.7$

2. Material Options

1. **One Suitable Material = ENSOLITE (Armacell LLC)** (characteristics on page 14)
2. Cellular material layer

1. Open-cell
2. Closed-cell (preferred)
3. Examples (or mixtures)
  1. Polyethylenes
  2. Polyvinyl chloride
  3. Polychloroprenes
  4. Nitriles
  5. Nitrile-butadienes
  6. Urethanes
  7. Latex materials
4. Rubber materials also work (man-made or natural)
  1. Neoprene rubbers
  2. Nitrile rubbers
  3. Natural rubbers
  4. Styrene-butadiene rubbers
  5. Ethylene propylene-diene rubbers
5. Polymeric material layer (one polymer or a blend)
  1. Viscoelastic

2. Rubber-like between temp 10-120 F

3. Examples

1. Foamed ethylene vinyl acetate
2. Foamed polyurethane
3. Foamed polyvinylchloride-polyacrylonitrile copolymer
4. Foamed elastomeric polypropylene

3. Thickness-

1. Depends on numerous factors including the wearer (300 lb man vs 100 lb woman) / running surface
2. **0.25 inches < t < 2 inches**
3. Vary or be the same throughout?
4. Adjustable components- Velcro / adhesive

4. Other features

1. Anti-fatigue mats
2. Reinforcement layer (increase life span)
3. Anti-slide wedge
4. **Compression of the heel has been found to be greater than the forefoot -> Hyperextension / pain in the knee**

2. Traction-

1. Function- provide traction / resiliency not found on the first layer
2. Specific material selection is less critical

1. Examples of possible materials

1. Solid rubbers

1. High carbon rubbers
2. Cross-linked rubbers

2. Fillers / other additives

1. Carbon fillers
2. Silica fillers

3. Shape

1. **Multiple Pieces to allow adjustments to get desired shape**

1. Replace pieces from wear without replacing entire device
2. Varied thickness throughout (try to minimize thickness)

2. Curved at front and back as to not hit the ground and replicate the shoe

4. Attachment

1. Velcro (removable)
2. Adhesive (permanent)

5. Grip (depends on use)

1. Runners on wet day (lots of traction)
2. Basketball player on floor (traction while running but not while pivoting)
3. **Overall grip depends on material and pattern!**

3. Securing Feature (Figures attached below)

1. Permanent

1. Adhesives that are not applicable to this device
2. Mechanical (ie screws)

2. Removable

1. Velcro
2. Loop Tensioning
3. Buckles
4. Straps
5. Laces...

3. Placement

1. Straps on toe and heels
2. Laces attached to ankle / toe

**Conclusions/action items:**

Use this patent to determine features of the design such as materials and securing feature. Discuss with the team to determine what is most suitable for the needs of our device.

Emily Johnson - Sep 12, 2020, 4:10 PM CDT

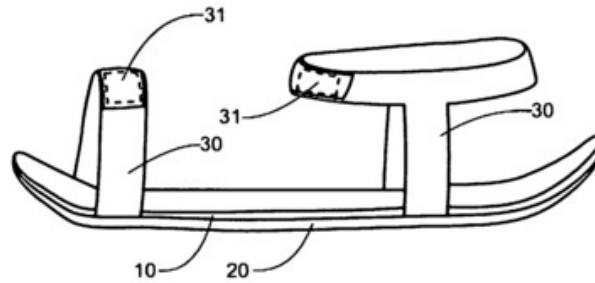

[US20130008052A1-20130110-Attachment\\_Method\\_1.png\(10.3 KB\) - download](#) Various attachment methods that the patent discussed utilizing in their device.

Emily Johnson - Sep 12, 2020, 4:10 PM CDT

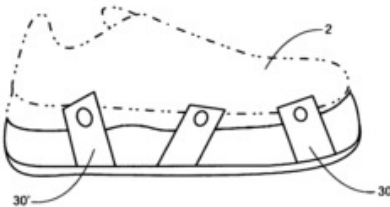

FIG. 4a

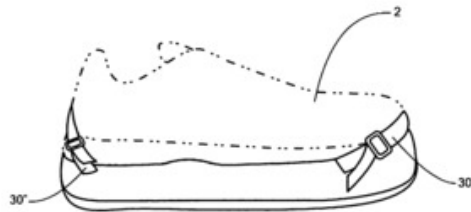

FIG. 4b

[US20130008052A1-20130110-Attachment\\_Method\\_2.png\(26.5 KB\) - download](#) Various attachment methods that the patent discussed utilizing in their device.

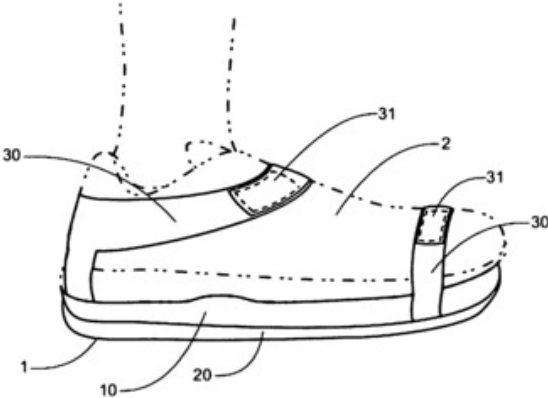

FIG. 2

US20130008052A1-20130110-Attachment\_Method\_3.png(16.2 KB) - [download](#) Various attachment methods that the patent discussed utilizing in their device.



## Sept 13- Running Shoe Soles

Emily Johnson - Sep 13, 2020, 10:32 PM CDT

**Title:** Shoe Sole of Athletic Shoe with High Running Efficiency

**Date:** September 13, 2020

**Content by:** Emily

**Goals:** Determine the components of the sole of a running shoe that are critical

**Content:**

Patent- US8863407B2

\*Trace movement during running varies to walking so the grooves for running shoes need to reflect this

### Figure 1

Groove 100- more flexible reverse surface (long distance running)

Trace of Movement 101- walk 1A, run 1B (differences listed below)

1. "Vicinity of center of heel upon first strike"
  1. Deform lateral side of back of foot
    1. First Contact
    2. Load is pushed toward the center of the foot
2. "Medial side of the middle foot portion"
  1. After first contact, the foot leans inwards (medial) -> load center stagnates (less efficient)
    1. Groove 100 is not sufficient compensation
    2. Need to hinder the foot leaning
      1. Smooth transition by impeding the sinking of the medial arch in the middle of the foot
3. "Vicinity of the center of the tiptoe upon takeoff"
  1. Surface contact is limited and can lead to instability (not wanted)
    1. Stabilize by having the sole bend at a specific location

### Current Model

*Depth = inner of groove to the tread surface*

"the shoe sole has a front foot portion, a middle foot portion and a rear foot portion continuous with one another in a front-rear direction of a foot, and has a medial side, a lateral side and a central portion between the medial side and the lateral side continuous with one another in a width direction of the foot, the shoe sole comprising: a midsole having an upper Surface and a lower Surface and absorbing an impact of landing; and an outsole placed below the midsole; the midsole includes a midsole body formed by a foamed resin in the front foot portion; the outsole is provided in the front foot portion and the rear foot portion; the middle foot portion supports an arch of the foot, and a reinforcement member is provided in the middle foot portion for Suppressing lowering of the arch; a depression is formed in the rear foot portion which extends forward from a calcaneal bone and which does not contact a ground; a band-like area is provided in the middle foot portion extending in the front-rear direction in the central portion so as to be continuous with the depression; the reinforcement member and the midsole are provided in the middle foot portion so that the upper surface of the midsole less easily sinks downward due to a load from above on the medial side than in the band-like area and on the lateral side; in the front foot portion, a longitudinal groove is formed in the midsole body and the outsole which extends in the front-rear direction in the central portion so as to be continuous with the band-like area; a depth of the longitudinal groove is 5 mm to 20mm; the longitudinal groove is provided to extend from a rear end of the front foot portion to a proximal interphalangeal joint of a second toe; the longitudinal groove is curved so as to be generally parallel to a lateral edge of the front foot portion of the midsole; a width and the depth of the longitudinal groove are smaller than those of the depression; and the depression, the band-like area and the longitudinal groove are Smoothly continuous with one another in the front-rear direction."

- Smooth transition of load center through the depression in the upper surface of the midsole because of the groove and band-like portion
  - Harder to sink on medial side
  - Efficient running!

- Reinforced / rigid on medial side - THICKER
  - More reinforcement structures
- Less rigidity on lateral side (band-like portion) - THINNER
- Smooth diagonal, kick-out towards the lateral side because out the groove that is sideways along the lateral edge
  - Depth- 5 mm to 20 mm (not uniform)
    - Smaller depth- less likely that the load center is in a groove
    - Larger depth- too thick and leads to slippage]
    - Preferred depth- 7 mm to 13 mm
  - Width- 10 mm to 60 mm (preferred 12 mm to 50 mm)
- Material
  - Support structure- non-foamed resin
  - Shape (many different options listed on page 16)
    - Medial side = rolled up
      - bridge piece extending slightly out from midsole for support (opt)
    - Lateral side =
      - rolled up near rear
      - supporting foot in rear
        - hole to support the sinking (topt)
          - Singular
          - Multiple
          - Mesh
          - U-shaped
      - makes sure that the upper surface of midsole sole sinks above the depression

### Methodology

- Look at figures attached below for better encompassment of the ideas listed above!

### **Conclusions/action items:**

Take the aspects of a shoe that leads to a smooth gate and therefore efficient running when designing the holder. By encompassing portions of actual running shoes we can minimize any gate changes with the device.

Emily Johnson - Sep 13, 2020, 10:35 PM CDT

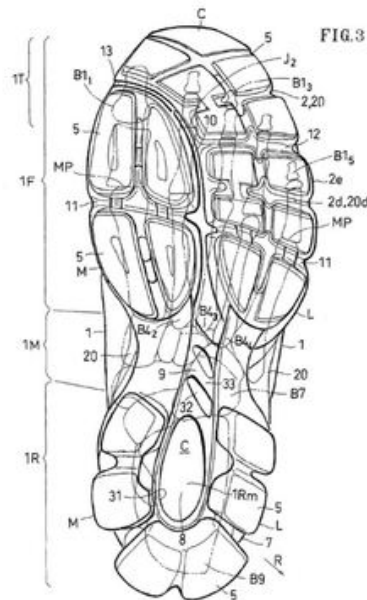

**Efficient\_Running- Example\_Tread\_Pattern.JPG(91.6 KB) - download** The tread pattern that the patent deemed optimized the efficiency of a runner along with the bones of the foot sketched lightly underneath.





## Sept 17- Belt with Expandable Pouch

Emily Johnson - Sep 17, 2020, 9:27 PM CDT

**Title:** Belt with Expandable Pouch

**Date:** Sept 17, 2020

**Content by:** Emily

**Present:** NA

**Goals:** Learn aspects of this design that could be incorporated into the design for the chest sensor.

**Content:**

Patent- US8104654B2

The invention (pictured below) is an expandable belt meant to be worn during running. The adjustable feature makes it versatile in the sense that it will fit a wide range of users. The pouch also sits tight on the user as to not allow items to move while performing vigorous activity. Also the belt of the invention is elastic as to even better fit the user. The belt is held on the idea of circular tension (much like a normal belt). One piece of fabric is utilized in the fabrication of the pouch as to keep it snug and not cumbersome. The tension around the objects help maintain its horizontal position as the width of the belt gets smaller. The soft material also minimizes chafing or an uncomfortable wear.

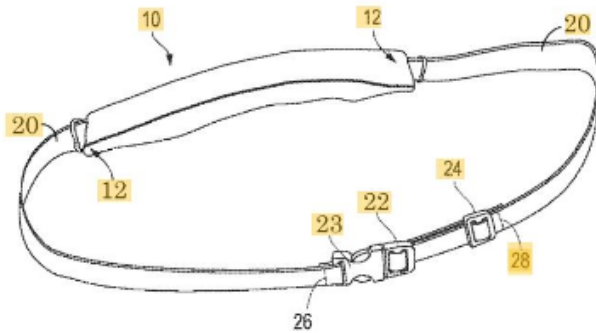

FIG. 2

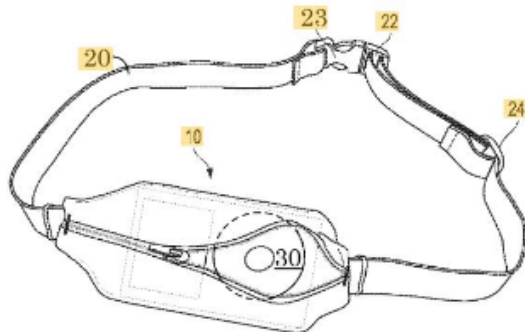

FIG. 3

**Conclusions/action items:**

Determine which aspects of the design work with our specific need then brainstorm a design. The ideas that seem most applicable are the securement / adjustability of the device along with the elastic material to maintain the sensor in place.



## Sept 28- GoPro Chesty

Emily Johnson - Sep 28, 2020, 3:55 PM CDT

**Title:** GoPro Chesty

**Date:** Sept 28, 2020

**Content by:** Emily Johnson

**Present:** NA

**Goals:** Research competing designs for the chest holder device.

**Content:**

No patent could be found for the GoPro Chesty although the device is rather simple and could be easily investigated by pictures alone. The design (attached below) has three straps encompassing the entire abdomen region with adjustments for each. The camera can be then mounted on the front plate for a crisp video. From personal experience, I know that the camera has little movement even during intense activity, which is important to take into account for our application of a similar idea.



Images found at <https://gopro.com/en/us/shop/mounts-accessories/chesty/AGCHM-001.html>

**Conclusions/action items:**

Utilize aspects of this device to design a supposed chest holder for a sensor. Continue to search and have teammates search for a patent or more information on the manufacturing of this model if chosen for the final design.

# Sept 28- Camera Harness

Emily Johnson - Sep 28, 2020, 4:06 PM CDT

**Title:** Camera Harness / Suspenders

**Date:** September 28, 2020

**Content by:** Emily

**Present:** NA

**Goals:** To gather more ideas for chest harness that are not as normal.

**Content:**

US Patent (US20160363838A1)

The patent encompasses a design to hold a camera at chest level. It is similar to suspenders as it attached to a mechanism around the waist of the user. Although this is not applicable for our purpose the design as a whole has positive features. Such as multiple attachment points and adjustability in a belt like fashion. The design is broken into multiple components as to fit various body topes and it made of a leather like material to better the stability.

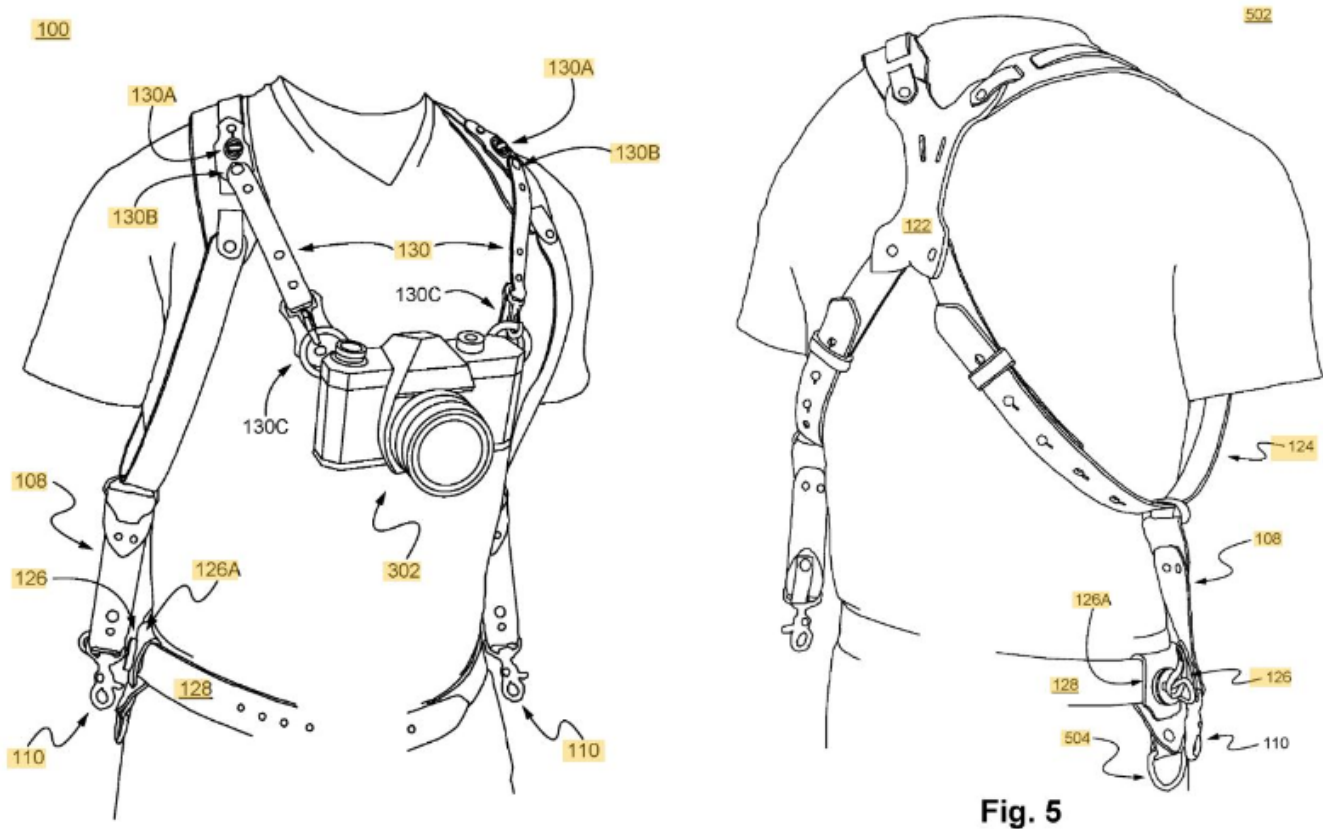

**Fig. 5**

**Conclusions/action items:**

Utilize aspects of this design to brainstorm a third chest holder that is not as predictable as others.



## Sept 17- Prelim Shoe Holder (Lace it up)

Emily Johnson - Sep 17, 2020, 8:51 PM CDT

**Title:** Brainstorm- Lace it Up

**Date:** September 17, 2020

**Content by:** Emily

**Present:** NA

**Goals:** Brainstorm random ideas to get possible ideas for the prelims

**Content:**

Attached below is the one possible design for the shoe holder. Running shoes in specific have an additional hole for the laces on top and certain runners utilize it to stabilize their ankles. The design encapsulates this idea and attaches on both sides through the additional loop. The tension from the shoe knot will keep it in place and it can be adjustable as it can be pulled as tight as necessary. The sensor is also secure with the multiple straps creating compression into the heel of the runner.

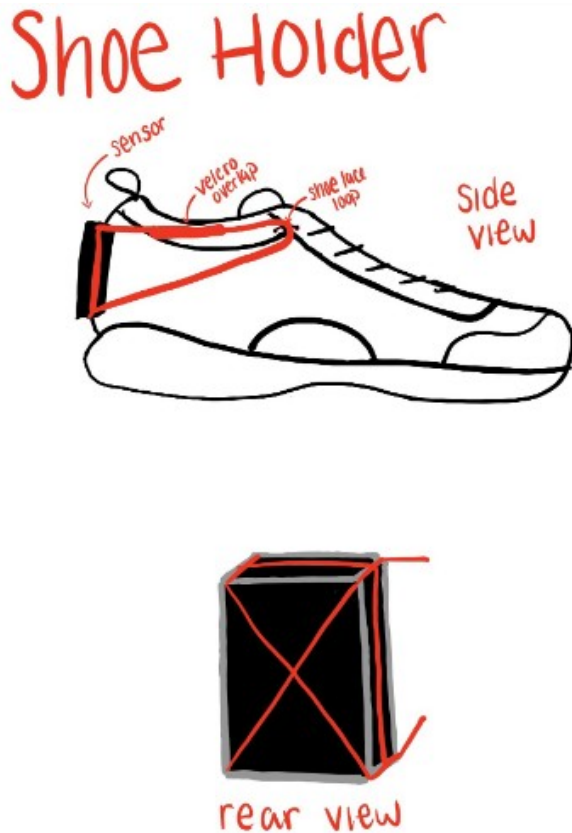

**Conclusions/action items:**

Discuss with team members to learn which designs are most suitable going forward.



## Sept 17- Prelim Shoe Holder (Goal Post)

Emily Johnson - Sep 17, 2020, 8:57 PM CDT

**Title:** Brainstorm- Goal Post

**Date:** September 17, 2020

**Content by:** Emily

**Present:** NA

**Goals:** Brainstorm random ideas to get possible ideas for the prelims

**Content:**

Attached below is the one possible design for the shoe holder. The holder is rather small and is attached on the heel by a spring inspired heel clamp. The sensor would be held in place by a combination of velcro attached to the shoe and the contraption sketched below. The design would need to be developed more to ensure stability but would easily fit on a wide variety of shoes. It would also be easy to fabricate as the components do not involve intricate mechanisms. The only slightly difficult fabrication is the clamp although from a little research there seems to be tutorials out there to accomplish this.

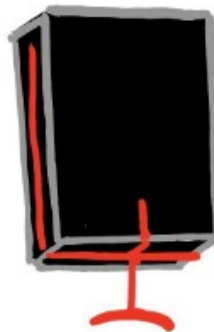
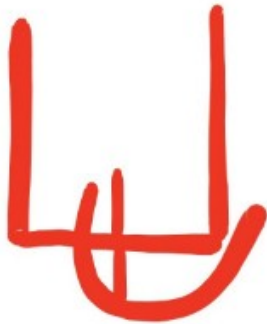

**Conclusions/action items:**

Discuss with team members to learn which designs are most suitable going forward.



## Sept 17- Shoe Holder Prelim (Up, Down and All Around)

Emily Johnson - Sep 17, 2020, 9:03 PM CDT

**Title:** Brainstorm- Up, Down and All Around

**Date:** September 17, 2020

**Content by:** Emily

**Present:** NA

**Goals:** Brainstorm random ideas to get possible ideas for the prelims

**Content:**

Attached below is the one possible design for the shoe holder. The holder works on the idea of compression from the device being on both the heel and the toe of the design. Although it may be difficult to fabricate for a variety of shoe sizes the sensor should be secure (velcro would be used as an additional adhesive method) especially if the design was elongated to encircle the entirety of the shoe and split in two to go around the sides. If this adjustment was made then a knot could be tied to better be suitable for a variety of shoe sizes. The design could possibly be initially fabricated with a piece of string to test the plausibility of the design before a better, more stiff material is purchased.

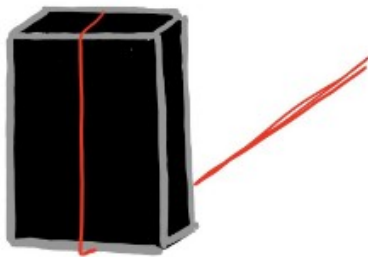

**Conclusions/action items:**

Discuss with team members to learn which designs are most suitable going forward.



## Nov 21- Ankle Holder for Testing

Emily Johnson - Nov 21, 2020, 12:10 PM CST

**Title:** Ankle Holder for Testing Components

**Date:** November 21, 2020

**Content by:** Emily

**Present:** NA

**Goals:** Design a holder for the components that Kiley needs to make our testing procedure possible

**Content:**

The design tried to comprise elements we already had available. It needed two pockets, one for the part and one for the battery. The design is simple as it needs to contain everything but it does not to be as secure in terms of placement as the other two. It will be made of the same nylon band as the chest design and the diameter will be made to fit my ankle as ian and I are the test subjects and I have the smaller ankle. The elastic properties of the strap means it would fit ian as well.

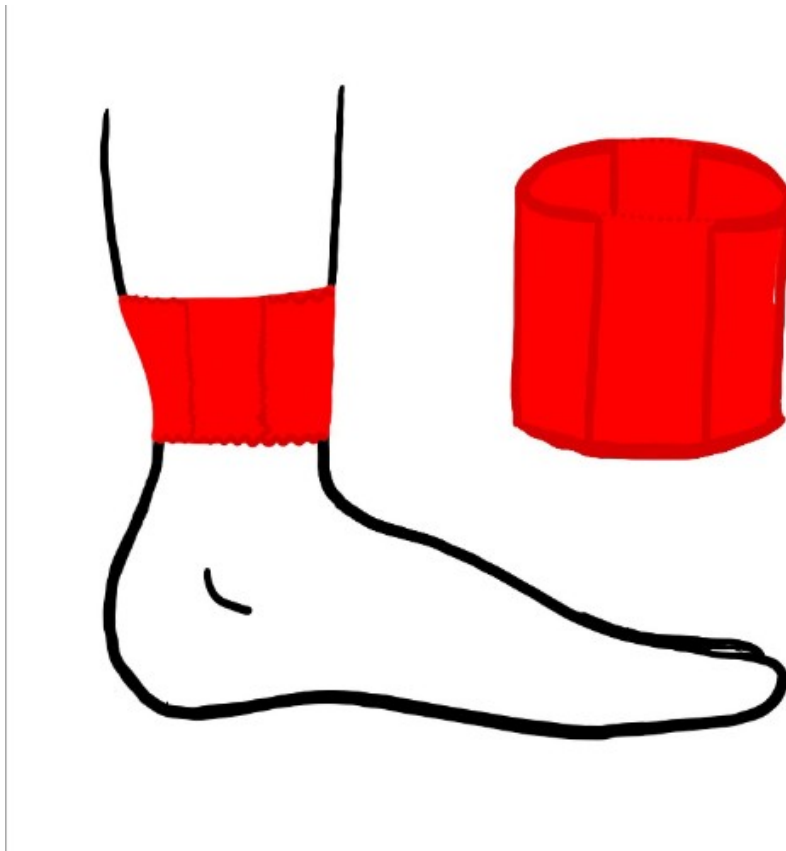

**Conclusions/action items:**

Use it in the testing protocol once the coding and stuff is done.



## Sept 17- Prelim Chest Holder (Fanny Pack)

Emily Johnson - Sep 28, 2020, 1:45 PM CDT

**Title:** The Fanny Pack Center of Motion Holder

**Date:** September 17, 2020

**Content by:** Emily

**Present:** NA

**Goals:** Brainstorm an idea for the COM sensor holder that is secure.

**Content:**

The idea for this design comes from the patent discussed in competing design (Sept 17- Belt..). As depicted in drawing below, the design will have the same belt like structure with elastic material. The adjustable component was not drawn but is expected to be applied. Furthermore, the pocket will be made of the same material of the pocket but with a smaller length as to be specific to the dimensions of the sensor. Proper adjustment (alluding human error) will allow the sensor to stay in place in the vertical direction although additional testing would have to be performed to determine if the design would move in either horizontal position.

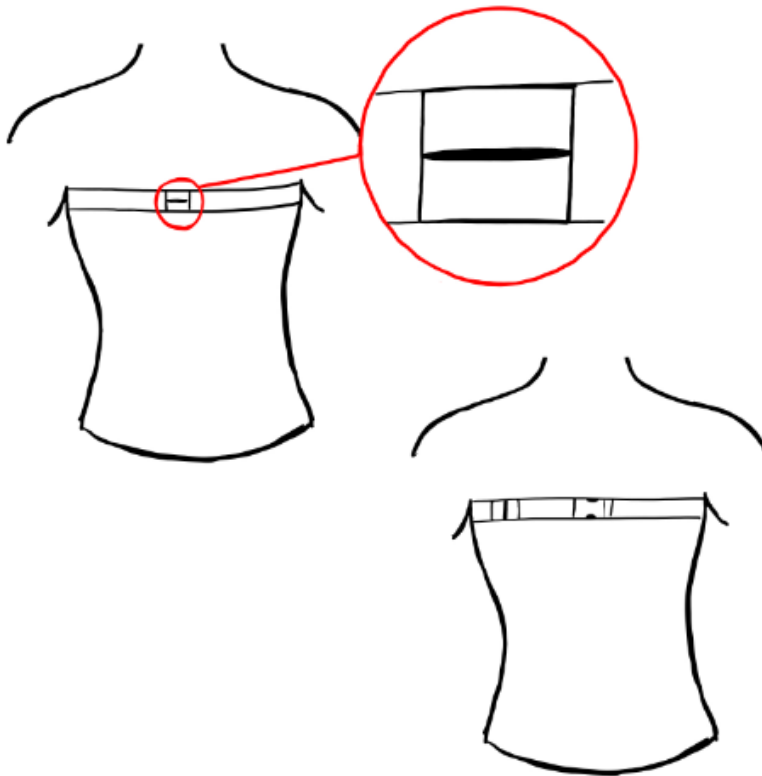

**Conclusions/action items:**

Discuss with the team about this idea and others that they might have. Either go forward with one of the ideas or combine multiple to form a new device.



## Sept 28- Prelim Chest Holder (GoPro)

Emily Johnson - Sep 28, 2020, 3:47 PM CDT

**Title:** GoPro Inspired Chest Holder

**Date:** September 28, 2020

**Content by:** Emily

**Present:** NA

**Goals:** Design another option for the chest holder design utilizing the design of the GoPro chesty

**Content:**

The design is based off the research of the "competing" designs for GoPro Chesty. The idea would be a three strap design that all are adjustable and attach in the front near the holder. The holder is composed of plastic L-shaped fixtures on the top and bottom plus an elastic, taunt velcro strap across to keep it completely secure. The design has great stability in all directions and is expected to keep the sensor in the correct vertical and horizontal positions if correctly adjusted. The multiple straps could cause more discomfort for the subject but this could be combated with the right material choice.

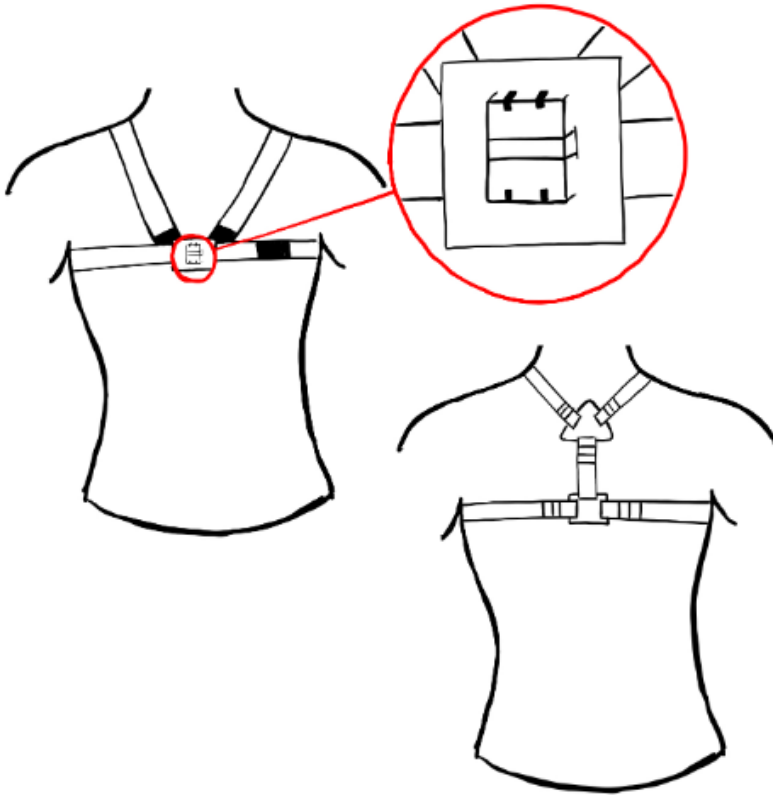

**Conclusions/action items:**

Discuss with team members to decide which chest holder would be most applicable and stable for our final design





## Sept 28- Prelim Chest Holder (Suspenders)

Emily Johnson - Sep 28, 2020, 4:17 PM CDT

**Title:** Suspenders Chest Holder

**Date:** September 28, 2020

**Content by:** Emily

**Present:** NA

**Goals:** To create a design that is reasonable but more out of the box than the previous two designs

**Content:**

The design is inspired by the camera harness patent found in camera harness. As seen below, the design is similar to lederhosens (German suspenders) with the positioning of the straps and the horizontal aspect connects the two vertical straps for additional stabilization. Compared to the other prelim chest designs, the sensor can be moved more easily to other positions on the abdomen if desired and the additional horizontal aspect can be moved as well between the multitude holes. The bottom waistband would be connect using velcro and the other connects would utilize velcro through the holes as well. The back horizontal strap it for additional stabilization.

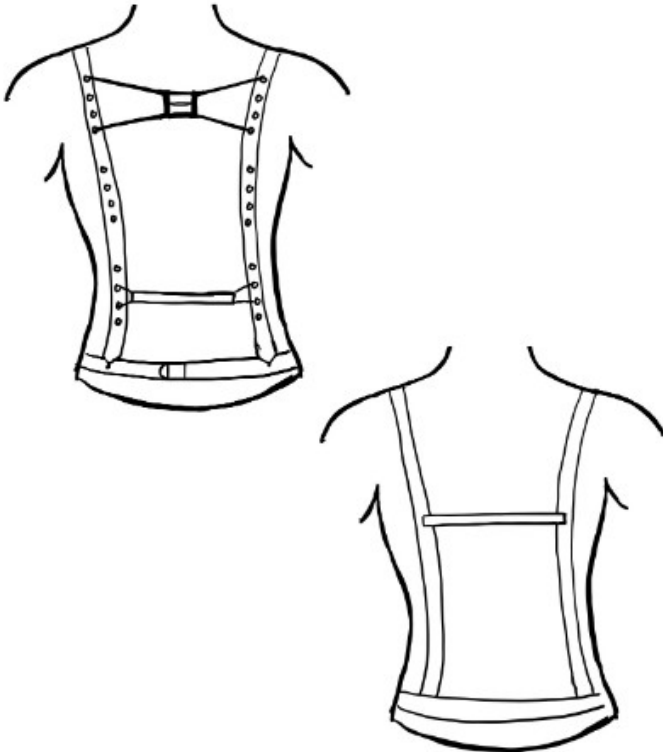

**Conclusions/action items:**

Fill out the design matrix with the three designs and determine which one is most suited for the purpose of our project.

# Oct 3- Green Pass

Emily Johnson - Oct 03, 2020, 3:05 PM CDT

**Title:** Green Pass Certification

**Date:** October 3, 2020

**Content by:** Emily Johnson

**Present:** NA

**Goals:** Demonstrate that I have my green pass from a previous semester

**Content:**

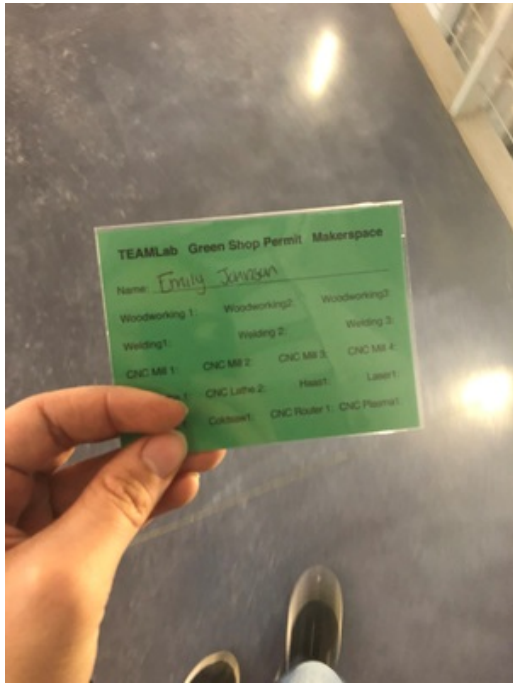

**Conclusions/action items:**

Utilize the green pass if possible to fabricate our multitude of designs



## 2020/09/28-Trigno Sensors

---

Kiley Smith - Dec 09, 2020, 12:21 AM CST

**Title:** Trigno Sensors

**Date:** Sept 28, 2020

**Content by:** Kiley Smith

**Goals:** To better understand how the sensors work

**Content:**

- Can connect to a Windows computer or to an Android
- EMG sensors along with contact data, force sensors, contact signals, and other timing
- Contains a 9 axis inertial measurement unit
- Can transmit 20m
- the IMU allows the sensor to measure acceleration in 3D
- Can receive data from up to 16 sensors
- The batter lasts from 4-8 hours
- The base station is plugged into your computer
- The input range for the sensors is 11 mV or 22 mV and the bandwidth is 20-450 Hz or 10-850 Hz respectively
- The accelerometer has a bandwidth ranging from 24-470 Hz
- The sampling rates are all configured by the software.
- The accelerometer is paired with a magnetometer to determine the orientation of the sensor
- Output data is expressed in Euler angles or Quaternions
- Analog pins can be used for outputting data
  - 1-16 are for EMG signals

<https://delsys.com/downloads/USERSGUIDE/trigno/wireless-biofeedback-system.pdf>

**Conclusions/action items:**

The data collected by these sensors is easily processed by their program and can be turned into velocity or force data as well. It will be important to know how the software works in order to use it to analyze our results. These are the sensors that Johnson Health Tech Currently uses in their testing. They would like to continue to use these sensors since they already have the proper protocols in place for analyzing the data and setting up the sensors.



## 2020/10/05- Shoe holder FBDs

Kiley Smith - Dec 09, 2020, 12:24 AM CST

**Title:** Shoe Holder FBDs

**Date:** Oct 5, 2020

**Content by:** Kiley Smith

**Goals:** Create FBDs that justify and explain stability rankings

**Content:**

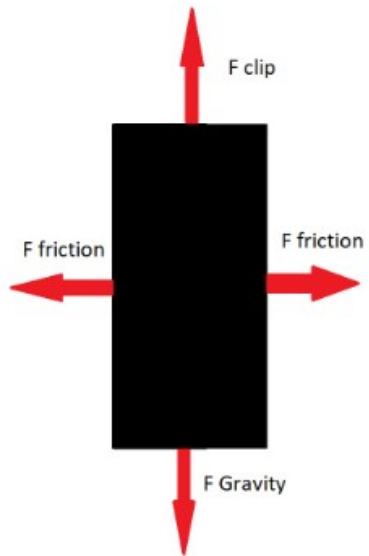

This FBD shows the clip option of our designs from the back. The clip will pull up to counteract the force of gravity and the pressure provided will add frictional forces to combat side to side movement. This will depend on the material used and the tightness of the clip. The force of the clip should equal the force of gravity to prevent the sensor from falling. The two frictional forces should be opposite and equal to prevent movement.

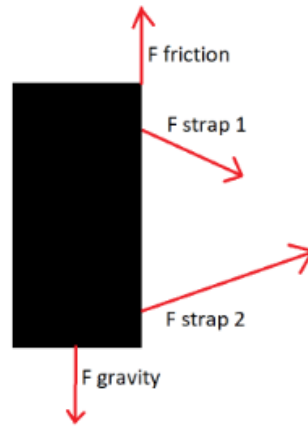

This FBD shows the straps design from the side. The force of the straps will help to prevent side to side movement and the tightness against the shoe will help create friction to counteract the force of gravity.

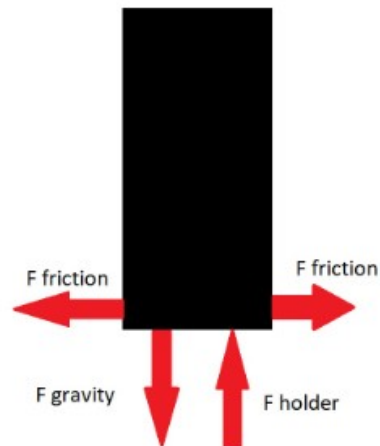

The last FBD shows the goal post design. There will be some friction to help prevent side to side movement but significantly less than the other two.

**Conclusions/action items:**

Build the designs and see if predictions hold true.



## 2020/10/24- Possible Accelerometers and Microcontroller For Testing

Kiley Smith - Dec 08, 2020, 8:53 PM CST

### Title: Circuitry for Testing

Date: Oct 24, 2020

Content by: Kiley Smith

Goals: Find a microcontroller and at least one accelerometer that we can use for testing.

### Content:

Since we do not know if or when we would gain access to the sensors used by Johnson Health Tech to measure acceleration and COM data, we will have to create our own to gather data. It would be preferable if the microcontroller had built in Bluetooth capabilities to decrease the size of the overall circuit.

The microcontroller that I found was the Adafruit ItsyBitsy nRF52840 Express - Bluetooth LE. It is 1.4" long and 0.7" wide so it has the capability to fit within our sensor holders. If it is too crowded with the accelerometer, it can be easily held elsewhere on the leg or shoe [1].

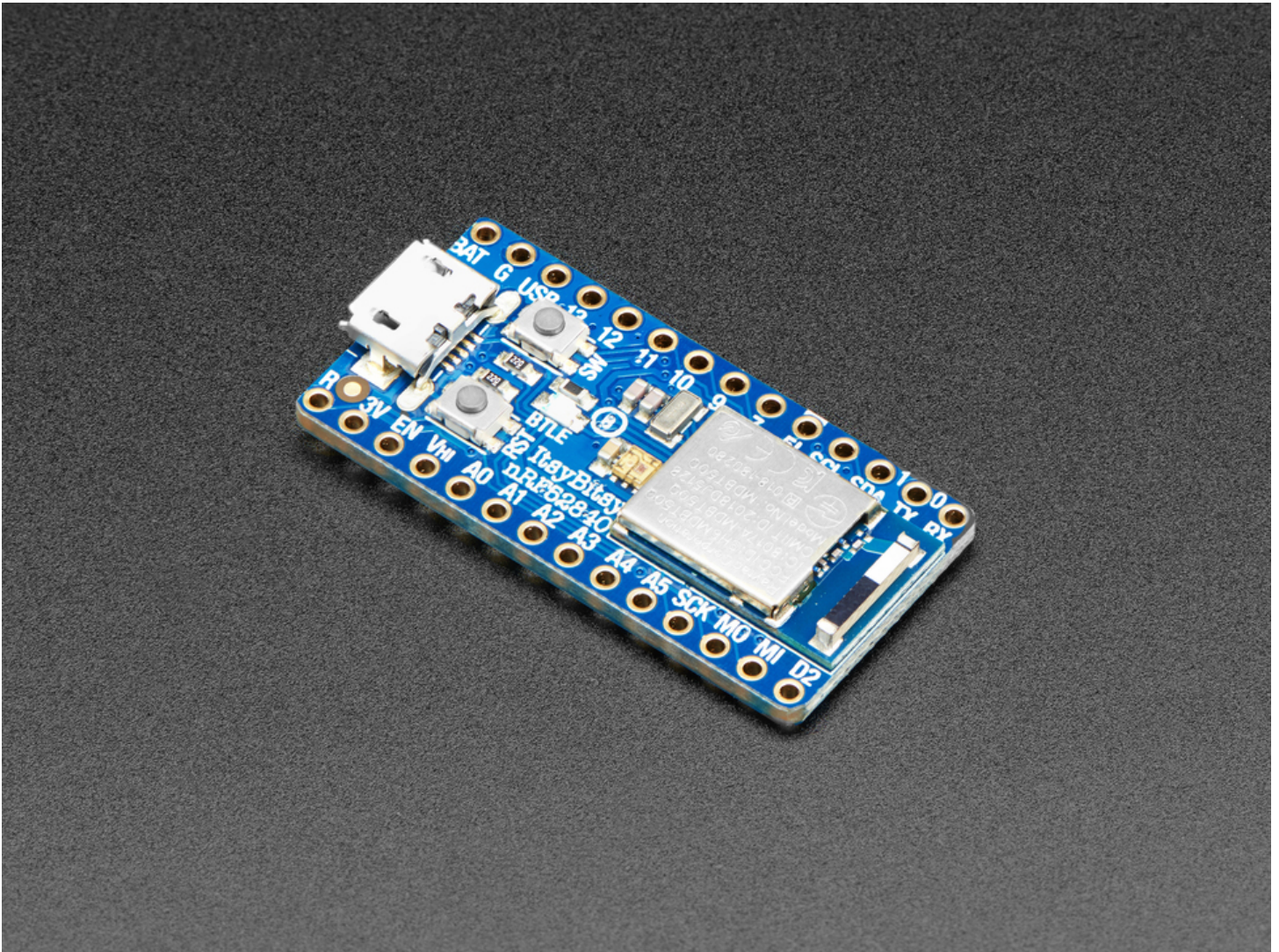

The first accelerometer that I found was the Adafruit LSM303AGR Accelerometer Magnetometer - STEMMMA QT Qwiic. It does not need to be soldered and has three axis of measurement. It is also small enough to fit within our current design at 1" by 0.7" [2].

The second accelerometer that is promising is the Adafruit LSM6DS33 + LIS3MDL - 9 DoF IMU with Accel / Gyro / Mag - STEMMMA QT Qwiic. It has the same dimensions as the previous accelerometer and uses I2C as well. They have the same accelerometer ranges of  $\pm 2/\pm 4/\pm 8/\pm 16$  g. However, the sampling rate for this sensor appears to be higher at 1.6 kHz [3].

### Conclusions/action items:

Build the designs and see if predictions hold true.

Sources:

[1] A. Industries, "Adafruit ItsyBitsy nRF52840 Express - Bluetooth LE." [Online]. Available: <https://www.adafruit.com/product/4481>. [Accessed: 17-Oct-2020]

[2]A. Industries, "Adafruit LSM303AGR Accelerometer Magnetometer - STEMMMA QT Qwiic." [Online]. Available: <https://www.adafruit.com/product/4413>. [Accessed: 17-Oct-2020]

[3] "Adafruit LSM6DS33 + LIS3MDL - 9 DoF IMU with Accel / Gyro / Mag [STEMMA QT Qwiic] ID: 4485 - \$9.95 : Adafruit Industries, Unique & fun DIY electronics and kits." [Online]. Available: <https://www.adafruit.com/product/4485>. [Accessed: 17-Oct-2020]



## 2020/12/09-FBD Equations

Kiley Smith - Dec 09, 2020, 10:24 AM CST

### Title: FBD Equations

**Date:** Dec 9, 2020

**Content by:** Kiley Smith

**Goals:** To create FBD equations to help justify our analysis of the designs

### Content:

I only created the equations for the designs that we created and if I were to do the calculations for the goal post design, the results would be similar to that of the clip.

$$W_{\text{Sensor}} = 14g$$

$$F_g = 9.81m/s^2 * 14g = 0.1372N$$

### ΘThe Clip

$$-F_g + F_{\text{Clip}} - F_{\text{Step}} = 0$$

$$-F_g - F_{\text{Step}} = -F_{\text{Clip}}$$

$$F_{\text{Clip}} = 0.1372 N + F_{\text{Step}}$$

### The Straps

$$\theta_{\text{Lace}} = 15^\circ$$

$$\theta_{\text{Strap}} = 20^\circ$$

#### X Direction

$$F_{\text{Shoe}} - F_{\text{Lace}} \cos \theta_{\text{Lace}} - F_{\text{Band}} \cos \theta_{\text{Strap}} = 0$$

$$F_{\text{Shoe}} = F_{\text{Lace}} \cos \theta_{\text{Lace}} + F_{\text{Band}} \cos \theta_{\text{Strap}}$$

#### Y Direction

$$F_{\text{Friction}} - F_{\text{Lace}} \sin \theta_{\text{Lace}} - F_{\text{Band}} \sin \theta_{\text{Strap}} + F_g - F_{\text{Step}} = 0$$

$$F_{\text{Friction}} = F_{\text{Lace}} \sin \theta_{\text{Lace}} + F_{\text{Band}} \sin \theta_{\text{Strap}} + F_g - F_{\text{Step}}$$

*\*Fstep is only applied when the user is running*

The weight of the sensor is 14g which equates to a force of 0.137N. Each design has to overcome the force of gravity when the user is standing still, and overcome the force due to the acceleration of the person's step when running. According to a study conducted by the university of Sydney, the range can be 0.8-1.5 know produced by a leg while running or jogging. The Clip design has to overcome that by ensuring that the wires don't slip. The straps rely entirely on the friction created by the straps pulling on the sensor. This could be potentially problematic if different shoes have different coefficients of friction leading some to perform well while the sensor slips for others.

<http://www.physics.usyd.edu.au/~cross/PUBLICATIONS/6.%20StandingForcePlate.PDF>

### Conclusions/action items:

Look further into the forces produced while running throughout the duration. Obtain a strain gauge to determine the force produced by the bands and straps in the straps design.





## 09/15/20 - Search for running straps/bands

IAN SCHIRTZINGER - Sep 15, 2020, 3:44 PM CDT

**Title:** Search for running straps/bands

**Date:** 09/15//2020

**Content by:** Ian

**Goals:** Search for existing methods/materials for holding devices onto runners and see if any of these could be implemented into our design.

**Content:**

Waste straps and armbands appear to be the most common methods to secure the phones of runners.

Link to some of the highest-rated bands: <https://www.verywellfit.com/best-cellphone-holders-2911298>

Waste strap could potentially be used to secure the COM sensor for our project.



<https://www.amazon.com/dp/B0752X9TMN?tag=dotdashwellf-20&linkCode=ogi&th=1&psc=1&ascsubtag=2911298%7Cn193a2fb0eea441cda68672b27262f33d20>

Link to a cheap (\$9) waste band that could be used to hold the COM sensor.

Another option could be to use some sort of adjustable elastic strap that would wrap around the back of the heel and over the foot. This would work for people with varying feet sizes but may not be the most secure solution. A possible strap for this design is here:



<https://www.amazon.com/Wetool-Replacement-Princeton-Energizer-Comfortable/dp/B07DRCWZXD>

This item is adjustable, contains a sticky strip to help resist slipping, and is cheap (\$12)

**Conclusions/action items:**

Because these items are cheap, they may be useful in developing prototype models for our design this semester. However, further options will have to be considered before we can move forward.

**Title: Material Search****Date:** 10/06/2020**Content by:** Ian**Goals:** Find possible materials that can be utilized in the Clip design**Content:**

The wire selected should be flexible enough to surround the heel portion of the shoe and be implanted beneath the sole of the runner's shoe. It should also be able to be bent in a fashion that is capable of securing the sensor in place. Additionally, the material must be strong enough to hold the model steady for the duration of the runner's test (estimating 30 minutes). \

**Option 1:** [Beadalon 49 Strand Beading Wire 0.024 in](#)

- This wire is typically used for creating jewelry which gives me confidence that it is malleable and capable of holding shape in different conformations.
- Nylon coated stainless steel
- \$15 for 30 feet
- There are a number of wires similar to this sold by Etsy, it might be worth evaluating a few slightly differing types.

**Option 2:** [BEADING STRING / BEADING Wire - Very Strong and Flexible](#)

- Stainless steel braided wires
- Only \$2.40 (another option from Etsy)

**Option 3:** [Safety wire available at shop@UW](#)

- Part #: 19113505
- Stainless steel wire
- 1800 ft in length, would need to find a smaller amount

**Conclusions/action items:**

It would be easier for me to go to a hardware store or anywhere that sells these types of wires so that I could test their mechanical properties first hand. It is difficult to find literature on any wire types other than orthodontist wires which are custom made and expensive. Ideally, the wire selected will be able to fray at the ends so that if tucked beneath the sole of the shoe the user will feel its presence as little as possible.



## Second search for Wire

IAN SCHIRTZINGER - Oct 19, 2020, 9:54 PM CDT

**Title:** Continue searching for an ideal wire to be used in the Clip design

**Date:** 10/19/20

**Goals:** Search for a wire that can be easily purchased and shows evidence that it is malleable while maintaining strong mechanical properties.

**Content:**

This size conversion chart which converts mm to gauge will be useful in my research moving forward:

- AWG is the American Wire Gauge (most common)
- SWG is the Standard Wire Gauge used in the UK (less common)

|                              |     |     |     |     |     |      |     |     |     |
|------------------------------|-----|-----|-----|-----|-----|------|-----|-----|-----|
| Size in mm                   | 0.2 | 0.4 | 0.5 | 0.6 | 1.0 | 1.25 | 1.5 | 1.6 | 2.0 |
| AWG* (gauge)                 | 32  | 26  | 24  | 22  | 18  | 16   | 15  | 14  | 12  |
| SWG* (approx. UK equivalent) | 36  | 27  | 25  | 23  | 19  | 18   | 17  | 16  | 14  |

[Jewelry Craft Wire for Jewelry Making, Anezus Craft Wire 18 Gauge Tarnish Resistant Copper Beading Wire for Jewelry](#)

- This wire costs just \$11 and can be purchased on Amazon Prime so it would be received quickly. The reviews say that it is malleable and holds its structure over time.

[1MM Thickness Silver Aluminum Wire, Bendable Metal Craft Wire](#)

- This wire is also supplied by Amazon and runs for just \$10
- It is an 18 gauge wire but comes in a number of different sizes if I decide on one later

\*I am also considering just using a coat hanger... my only concern is that it will be a bit too rigid and therefore uncomfortable for the user. I will have to test this out with a prototype to see if it is feasible.

**Conclusions/action items:**

The first wire listed here is one that I will likely end up ordering to test if wires typically used for jewelry and crafts are a realistic material for the Clip holder design. I will also test out the coat hanger model to see if that is feasible.



## 09/15/2020 - Preliminary Design Options

IAN SCHIRTZINGER - Sep 15, 2020, 4:39 PM CDT

### Title: Preliminary Design Ideas

Date: 09/15/2020

Content by: Ian

**Goals:** Generate some ideas for how to attach sensors to the heels of runners without impeding on their natural gait too much.

### Content:

"Clip" - This holder would be made so that it simply needs to be slid onto the heel of the shoe. One end of it would be inside the shoe to provide support. The other end would have an attached component that is capable of securely holding the sensors. This design would easily fit multiple different shoe sizes but would partially impede the runner's gait.

"Strap" - This holder would consist of a strap going from around the heel of the shoe to over the top by the laces. If using an adjustable strap, this could be applied to multiple different shoe sizes. The durability of this holder would need to be tested because I am unsure that this would securely hold a sensor for long periods of time while in motion.

"Modified Strap" - This strap would be similar to the design listed above, but there would it would go around both the laces and the bottom of the shoe (in the sole region) for added stability. This would impeded the runner's gate a bit, but with the right material, this could be minimized.

### Conclusions/action items:

These designs are all plausible, however, more brainstorming will need to be done before our team can confidently choose which direction we'd like to take this project.

IAN SCHIRTZINGER - Sep 24, 2020, 3:28 PM CDT

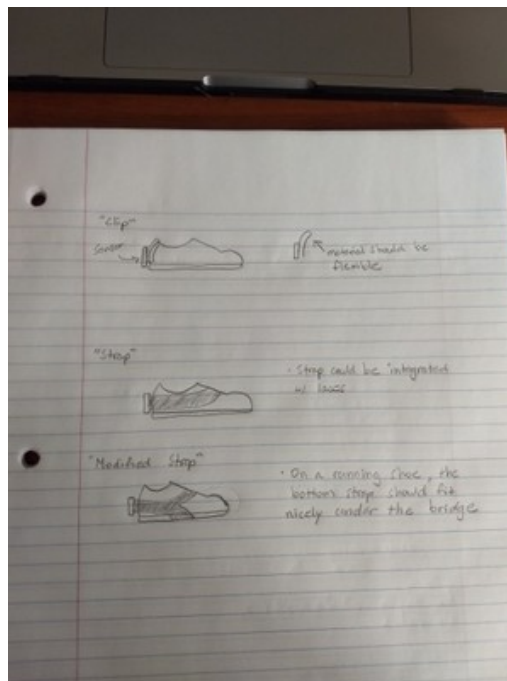

17a04fdf-cd6d-4805-af59-6fec7ae58c7d.jpg(40.1 KB) - [download](#)



IAN SCHIRTZINGER - Sep 24, 2020, 3:55 PM CDT

**Title: Clip Design version 2****Date:** 9/24/20**Content by:** Ian**Goals:** Generate ideas for how to make the clip design more feasible.**Content:**

The clip design has some key advantages over other competing designs that make it my most attractive option. One of these advantages is that it can easily be placed onto the back of any shoe, regardless of size. Therefore there will be no need to make it adjustable, driving down complexity and cost. An additional advantage is that it uses very minimal material, making it lightweight and minimally cumbersome. Another pro for this design is that it would be very easy for the user to take on and take off.

However, this design presents its own unique challenges. The first major challenge is that the portion of the clip that will be located inside the shoe must not cause discomfort or injury to the runner. This means that the existing material/design of choice must be modified (metal will not do). The other problem with this design (and all designs for that matter) is that we must verify that it can hold the sensor securely in place. Therefore, I must come up with a modification to this design that is comfortable for the user while still strong enough to hold the sensor securely in place.

I am planning now to implement wires into my design. This would allow me to avoid the region directly behind the heel (the location where most contact would occur) by running two high strength wires on opposite sides of the heel as shown in the image below. I am considering placing fabric over the wires to make the design even more comfortable. The concerns with this design include strength and longevity.

**Conclusions/action items:**

This design is certainly an upgrade from the previous model but there is more work and testing that needs to be done.

IAN SCHIRTZINGER - Sep 24, 2020, 3:55 PM CDT

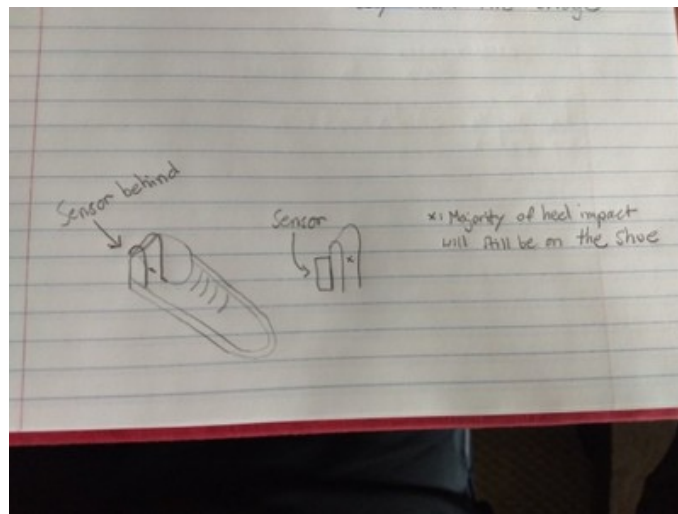
c03d3538-2d6d-45b2-a2a5-15076cc5459d.jpg(40.7 KB) - [download](#)



## Sensor holder design

IAN SCHIRTZINGER - Oct 06, 2020, 7:56 PM CDT

### Title: Sensor Holder Design

**Date:** 10/06/20

**Content by:** Ian

**Goals:** Design a method to secure the sensor holder to the back of the shoe and attach it to the wires that will run over the heel and potentially under the sole.

### Content:

The method that is depicted by the attached sketch uses just four wires. Even before testing this technique, you can identify some likely pros and cons. Some of the upsides are that it will be very lightweight, cheap, and thus a good candidate for a single-use holder. However, I am unsure of how well this current design will hold up while the user is running. The strength of this design relies heavily on the quality of the wire material selected.

A slight modification that could be made to this design that would increase the stability of the sensor would be to wrap the wires in electrical tape. This would not only provide increased stability for the wires but increased friction for the sensor as well. Electrical tape could surround the wires creating a sort of holster, a tab could even be left on the top that could cover the sensor during use ensuring that it does not fly out of the holder.

### Conclusions/action items:

I will likely test out both of these design ideas for the sensor holder to see which one is more feasible. Additionally, because this design simply consists of wires, it will likely be easy to attach to any sensor holder if one of my teammates is able to come up with a secure solution.

IAN SCHIRTZINGER - Oct 06, 2020, 7:57 PM CDT

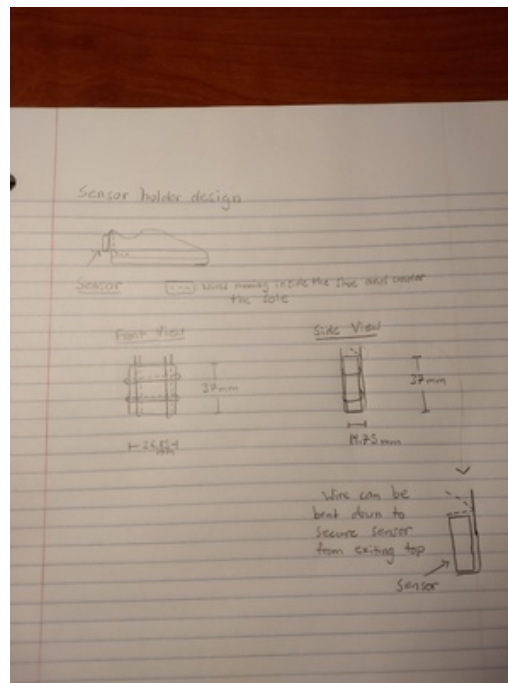

IMG\_20201006\_194816590.jpg(3.1 MB) - [download](#)



# Clip prototype A

IAN SCHIRTZINGER - Dec 03, 2020, 1:31 PM CST

**Title:** Clip prototype - proof of concept

**Date:** 10/16/20

**Content by:** Ian

**Goals:** Work with whatever materials I can find to developed a "proof of concept" prototype testing for the feasibility of the design.

**Content:**

- I decided to use pipe cleaners as my wire material because I had this item on hand and it possesses properties most similar to what I am looking for.

- I created two simplistic prototypes, one using only two pipe cleaners and another using four. I used four pipe cleaners in one design because the length of a single pipe cleaner was not long enough to model an accurate representation of the intended final product.

Small design:



Large (four pipe cleaner design) design:

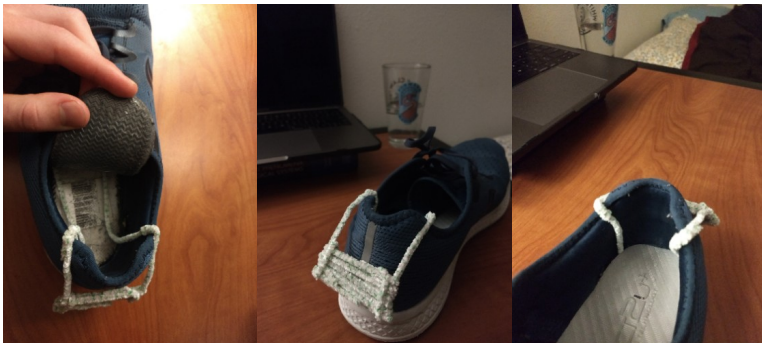

- As you can see in the far left image, the "wires" from the models are run underneath the sole of the user's shoe so that when the user steps on them he is actually applying some of the force that is being used to hold them in place. This same technique is used in the small design above.

- Additionally, you can see that when more wire is available we are able to run the wire along the sides of the back of the shoe. Avoiding any direct contact with the most posterior part of the heel.

Both designs outside of the shoe:





- I wore the larger design around for roughly five minutes and found that it was relatively comfortable. The only issues I had were with the pipe cleaners themselves.

**Conclusions/action items:**

This "proof of concept" prototype was a success. It showed me that if this design is created with the appropriate materials it can be successful.

# Clip prototype B

IAN SCHIRTZINGER - Nov 04, 2020, 8:54 PM CST

**Title:** Clip prototype B - with the first ordered wire material

**Date:** 10/23/20

**Content by:** Ian

**Goals:** Construct a prototype version of the Clip model with the 18 gauge wire I recently received.

**Content:**

The prototype was modeled after Clip prototype A. The wires on adjacent sides were run along the outsides of the shoe (out of any contact with the runner's heel) and down beneath the sole. Beneath the sole, the wires are crossed over symmetrically to ensure stability and comfort for the user (if they feel anything at all). I tested the model myself on a brief 10-minute run and found that it maintained its structural integrity and did not impede on my natural gait hardly at all.

Pictures of this design are below:



The TikTok box was used as my model sensor. For the sake of this prototype, I simply taped the wires to the box. In the future, we will have to develop an easy way to attach the wires to the 3D printed sensor holder that Quinton is working on.

I also checked all of my roommates' athletic shoes to ensure that the sole can be removed in all of them because this is an integral part of our design. Each shoe that I checked had removable soles.

**Conclusions/action items:**

The design worked well considering it is only a prototype. It was comfortable and durable over the course of its roughly 10-minute trial. I am considering using two wires on each side to further increase the strength and rigidity of the model. An alternative route to achieve this would be to purchase wire with a smaller gauge (such as 16 or maybe even 14).



## Testing the Clip prototypes

IAN SCHIRTZINGER - Nov 18, 2020, 6:18 PM CST

### Title: Testing two of the Clip designs

**Date:** 11/18/10

**Content by:** Ian

**Goals:** Go on a 15 minute run over a couple of different terrains to test for both the comfort and durability of the designs.

### Content:

I used both the 18 gauge copper wire and the newly acquired 16 gauge steel wire to create two similar Clip prototypes. At the time, I only have one "model sensor" (a tic-tac box) so I attached the copper model to this and left the steel model unattached. The images below were taken before, during, and after (from left to right). The copper model was on my right foot and the steel wiring was on my left.



Looking at the copper wire Clip model, you can see that the overall structure of the design was maintained throughout the course of the run. This is not the same for the steel wire model however it is not appropriate to judge this version on its structural integrity given that it is not a complete model. Determining the comfort of each model was the biggest reason that I conducted this test. Over the course of my run, I barely felt the presence of either the copper or steel wires. I rated each of these designs below where a 10/10 would indicate the regular comfort given no alteration to the shoe at all.

Copper model (18G): 9.5/10

Steel model (16G) : 8/10

I could hardly notice the presence of the copper wires at all, which is why I gave it such a high score. At times I could feel the steel wires, specifically while turning, and thus I deducted a couple of points there. In neither of the designs did I experience discomfort or pain.

### Conclusions/action items:

Both designs performed much better than I anticipated in the comfort category. Once I receive my model sensors I will be able to complete more accurate prototypes to test. Additionally, once we have working circuitry for the MIUs we will be able to test how well these models can hold the sensors in a stable position.



## 2020/09/17 Preliminary Design Idea [Shoe Holder]

QUINTON HENEY - Sep 17, 2020, 4:40 PM CDT

**Title:** 1st Design Idea for the Shoe Holder

**Date:** 9/17/2020

**Content by:** Quinton Heney

**Present:**

**Goals:** Develop a design idea for securing the EMG sensor to the shoe.

**Content:**



The sensor fits into the holder and is secured by clips. A strap, that connects with velcro or some other type of hook mechanism, wraps under the shoe laces to secure the sensor holder to the shoe.

**Conclusions/action items:**

Draft a more specific idea for the holder itself, possibly in SolidWorks, and get accurate dimensions to possibly 3d print or fabricate with some other material.

QUINTON HENEY - Sep 17, 2020, 4:33 PM CDT

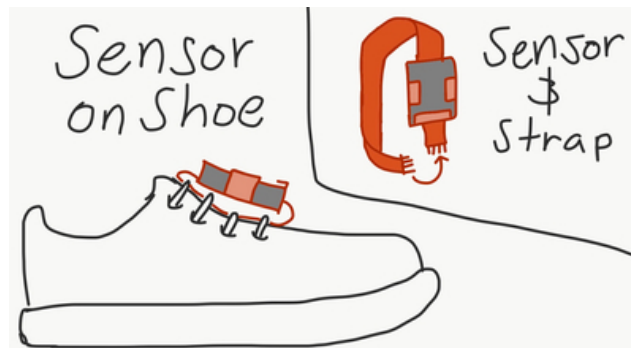

Footbit\_Sensor\_Holder.jpg(379.6 KB) - [download](#)



## 2020/09/17 Preliminary Design Idea [Chest Holder]

---

QUINTON HENEY - Sep 17, 2020, 5:35 PM CDT

**Title:** 1st Design Idea for the Chest Sensor Holder

**Date:** 9/17/2020

**Content by:** Quinton Heney

**Present:**

**Goals:** Draft an idea for the sensor holder that goes across the chest

**Content:**

- Preliminary idea: model the holder based off of a heart rate monitor strap
  - Use an adjustable strap similar to Polar, iFit, or Garmin
  - The sensor won't fit on like an aforementioned heart rate monitor normally would
    - Instead, a sensor holder would be fitted around the strap with a functionality that would allow the sensor itself to be placed on it

**Conclusions/action items:**



## 2020/10/01 Solidworks holder design

QUINTON HENEY - Oct 01, 2020, 1:48 PM CDT

**Title:** Designing the Holder for the sensor in SolidWorks

**Date:** 10/1/2020

**Content by:** Quinton

**Present:**

**Goals:** Create a first draft of a sensor holder design that would hold the delsys trigno sensor upright

**Content:**

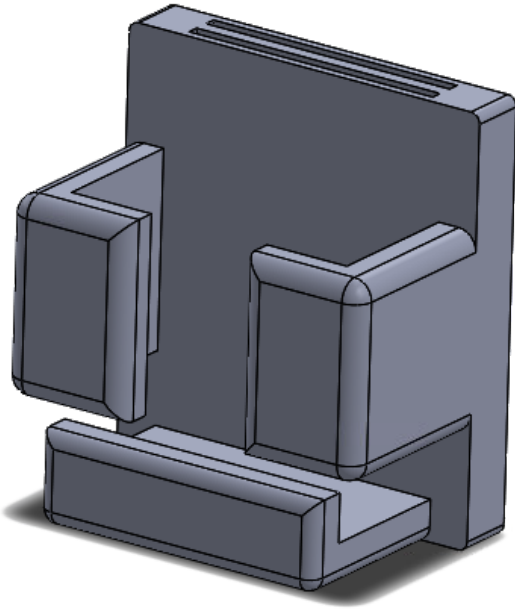

*figure 1:* A full 3D model of the sensor holder at ~an isometric view

The cut out area on top, and not shown cut out on the bottom, were originally for looping a piece of stretchable fabric through in order to affix the holder to the other components

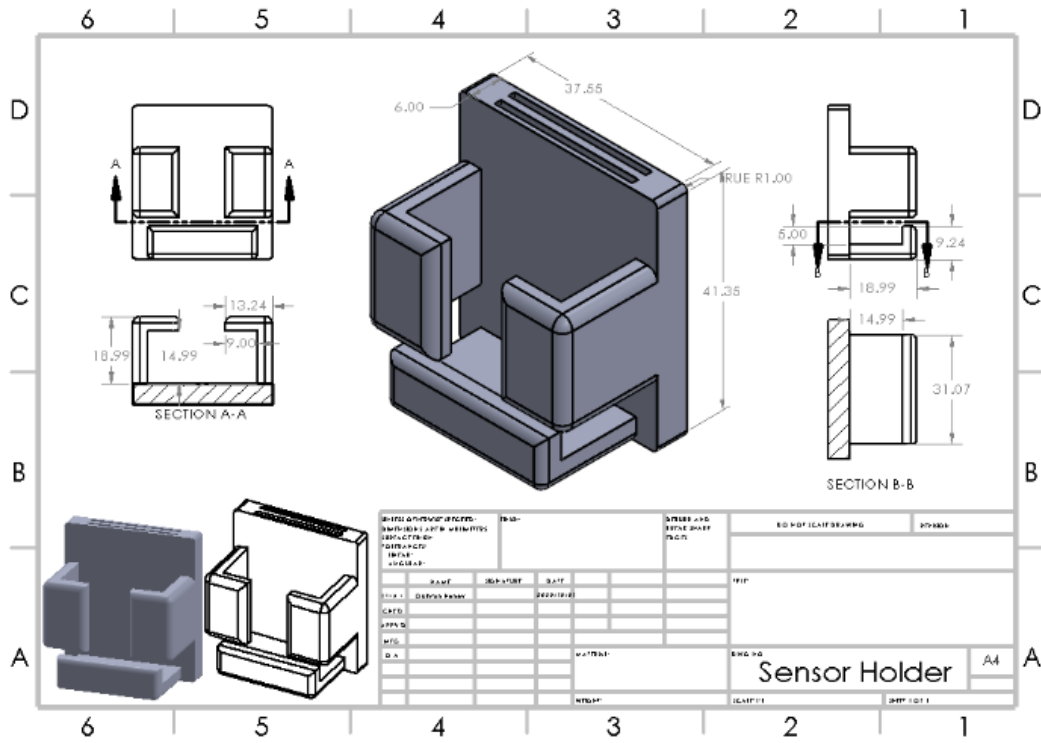

figure 2: A part drawing of the sensor holder showing the dimensions in millimeters

**Conclusions/action items:**

Knowing the Delsys Trigno™ approximated dimensions as 37.0 mm x 26.85 mm x 14.75 mm and that the dimensions of the cavity are 39.11 mm x 31.07 mm x 14.99 mm, there should be ample room for the sensor to fit in, especially since the sensor has a distinct but minimal curve that may affect the total thickness necessary. Overall, the sensor has a total of 2.11 mm, 4.22 mm, and 0.24 mm of extra space for the respective dimensions.

This sensor holder is subject to change based on the design we choose and any adjustments to the dimensions including, but not limited to, updated knowledge of the sensor dimensions, a need to change the allotted extra space for the sensor, or the ease of fabricating a, possibly 3D-printed, part at the current scale.

QUINTON HENEY - Oct 01, 2020, 1:52 PM CDT

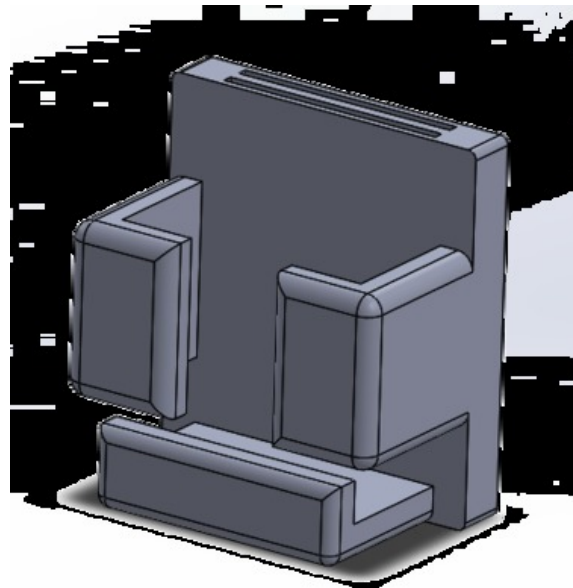

holder.PNG(45.3 KB) - download A .png image of the Sensor Holder without the sensor. While the image looks... odd, the entire background IS transparent and was removed in Adobe Photoshop

QUINTON HENEY - Oct 01, 2020, 1:53 PM CDT

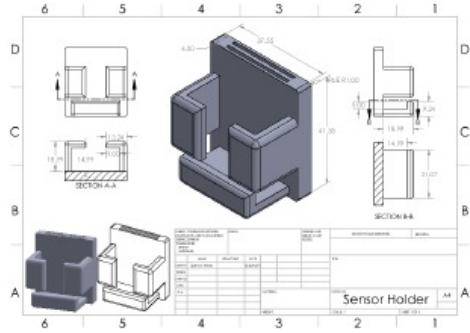

**Sensor\_Holder.pdf(146.3 KB) - download** A document file (.pdf) of the part drawing that details measurements of the sensor holder design.

QUINTON HENEY - Oct 01, 2020, 1:58 PM CDT

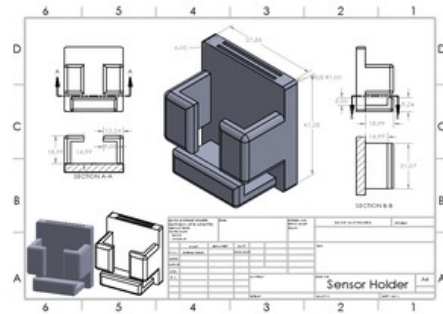

**Sensor\_Holder.PNG(57.2 KB) - download** A .png image of the part drawing that details measurements of the sensor holder design. Only to be used to referenced sparingly since the image seems to be of a lower quality than the pdf, it's best usage would be as shown in the main journal entry, in a medium where a pdf would be inappropriate to view.





## 2020/10/07 Goal Post Holder SolidWorks Design

QUINTON HENEY - Oct 07, 2020, 10:03 PM CDT

**Title:** Goal Post Holder SolidWorks Design

**Date:** 10/7/20

**Content by:** Quinton Heney

**Present:**

**Goals:** Create a SolidWorks design of the highest rated preliminary design, the Goal Post

**Content:**

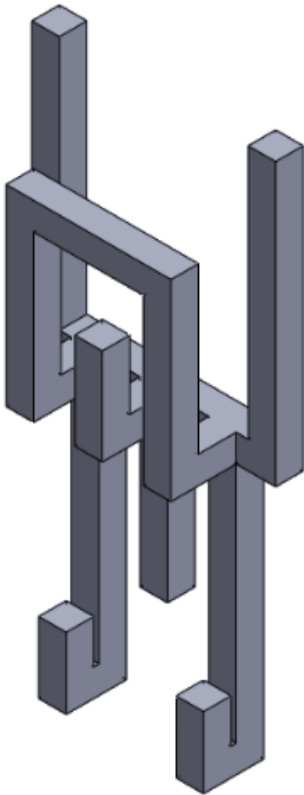

Figure 1: The Goal Post Holder part that the sensor fits into

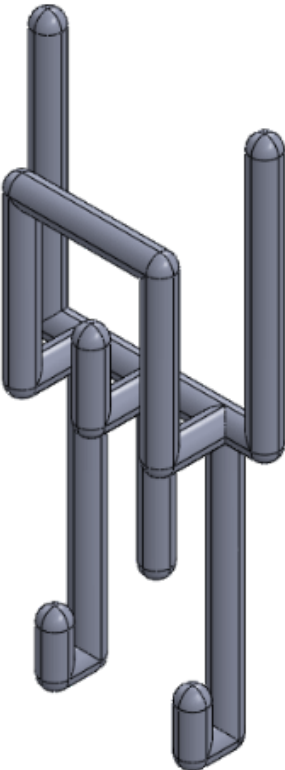

Figure 2: A second creation of the goal post holder in SolidWorks, this one has been filleted to more closely resemble stainless steel wire

**Conclusions/action items:**

---

QUINTON HENEY - Oct 15, 2020, 2:02 PM CDT



goalpost\_holder.SLDPRT(315.6 KB) - [download](#)

QUINTON HENEY - Oct 15, 2020, 2:02 PM CDT

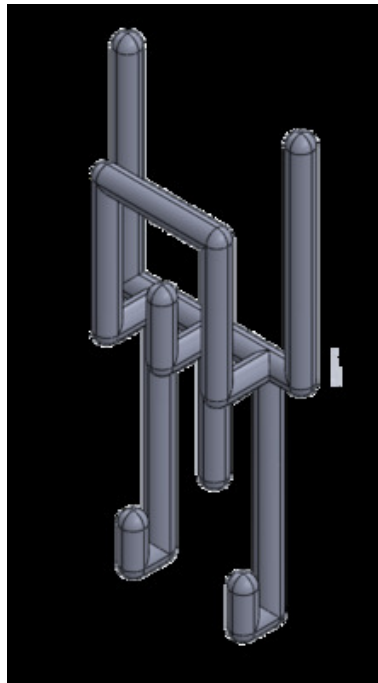

Goalpost\_Holder\_2.PNG(41.3 KB) - [download](#)

QUINTON HENEY - Oct 15, 2020, 2:02 PM CDT

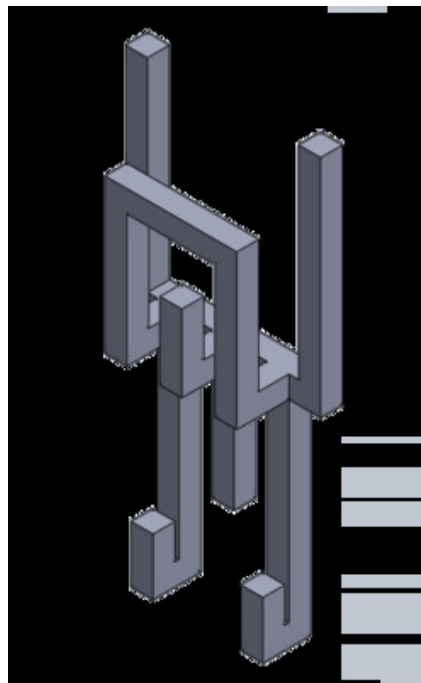

Goalpost\_Holder.PNG(22.2 KB) - [download](#)

QUINTON HENEY - Oct 15, 2020, 3:45 PM CDT



goalpost\_holder.SLDDRW(328.5 KB) - [download](#)

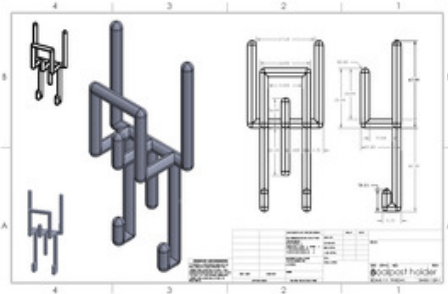

goalpost\_holder.PNG(51.7 KB) - [download](#)



## 2020/10/15 Clip Holder SolidWorks Design

QUINTON HENEY - Oct 15, 2020, 3:57 PM CDT

**Title:** Clip Holder SolidWorks Design

**Date:** 10/15/20

**Content by:** Quinton Heney

**Present:**

**Goals:** Create the SolidWorks design for the clip sensor holder

**Content:**

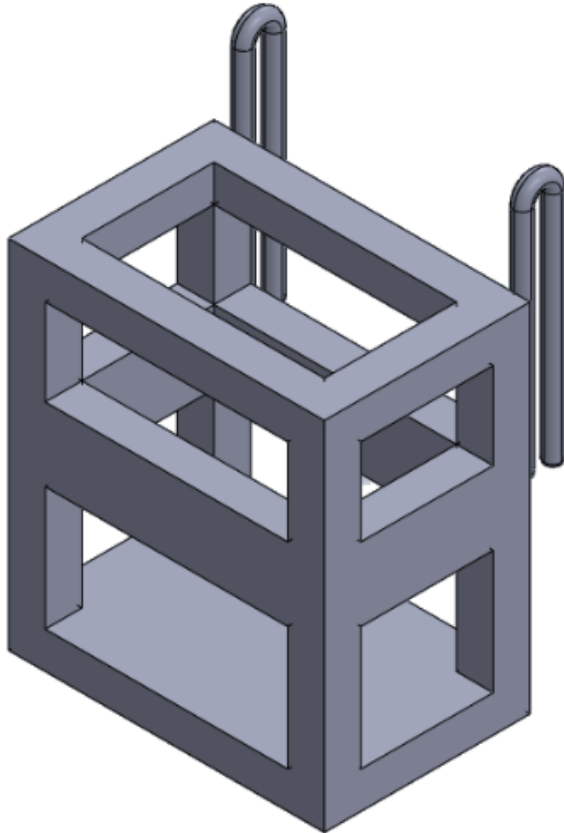

Figure 1: The sensor holder for the "clip" design modeled in SolidWorks. The holder consists of a 3D-printed plastic holder affixed to stainless steel wires that loop over the back of the shoe.

**Conclusions/action items:**

In reality, the holder and stainless steel wire loop would not be oriented parallel to each other due to the shape of the back of the shoe which must be accounted for and I'm afraid that is either very difficult or impossible to do in SolidWorks.

QUINTON HENEY - Oct 15, 2020, 3:47 PM CDT



clip\_holder.SLDPRT(252 KB) - [download](#)

QUINTON HENEY - Oct 15, 2020, 3:47 PM CDT



**clip\_holder.SLDDRW(251.7 KB) - [download](#)**

QUINTON HENEY - Oct 15, 2020, 3:47 PM CDT

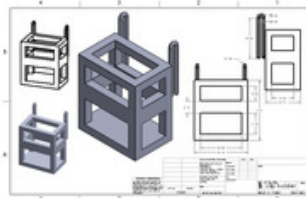

**clip\_holder.PNG(37.2 KB) - [download](#)**

QUINTON HENEY - Oct 15, 2020, 3:47 PM CDT

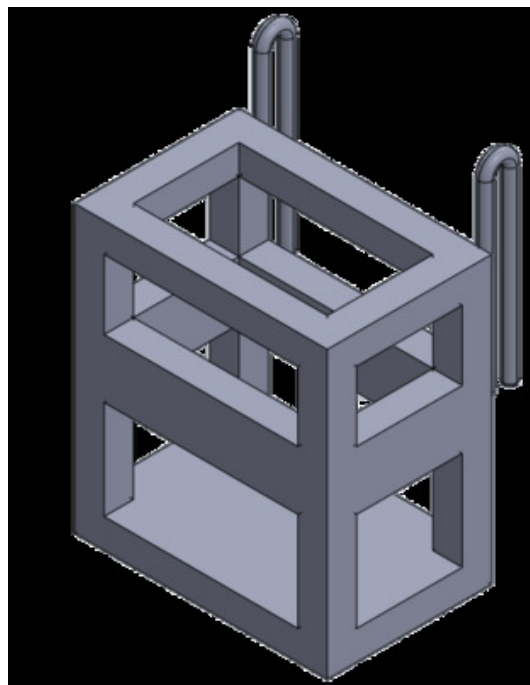

**the\_clip\_holder.PNG(53.5 KB) - [download](#)**



## 2020/10/29 Delsys Trigno Sensor

---

QUINTON HENEY - Oct 29, 2020, 2:05 PM CDT

**Title:** Delsys Trigno Sensor

**Date:** 10/29/20

**Content by:** Quinton Heney (Staci Quam)

**Present:**

**Goals:** Upload the CAD files of the Delsys Trigno Sensor

**Content:**

Included are .stp and .sldprt files sent by Staci Quam and Johnson Health Tech to help us 3D print a model to practice our designs with.

After running an import diagnostic, SolidWorks found 326 "faulty faces." This seems bad, but the problem message is only that "[the bodies] cannot be modified. The owning feature must be unlinked..."

**Conclusions/action items:**

Figure out if the error given by the diagnostic run will prevent or hamper 3D printing. If things can be fixed or are fine, we can go ahead and 3D print.

---

QUINTON HENEY - Oct 29, 2020, 2:07 PM CDT



Classic\_Trigno\_Enclosure.SLDPRT(2.1 MB) - [download](#)

---

QUINTON HENEY - Oct 29, 2020, 2:07 PM CDT



Classic\_Trigno\_Enclosure.stp(2.8 MB) - [download](#)



## 2020/12/02- Chest Holder Design Finished

QUINTON HENEY - Dec 02, 2020, 10:35 PM CST

**Title:** Completed Chest Strap and Sensor Holder

**Date:** 12/2/20

**Content by:** Quinton Heney

**Present:**

**Goals:** Finish sewing the sensor holder to the chest strap

**Content:**



Figure 1: The sensor holder "pocket" sewn to the chest strap. side-by-side.

Figure 2: A visualization of how the sensor fits into the pocket.

Figure 3: The pocket and sensor





Figure 4a, 4b: The full chest holder with attached pocket. Kiley holding the chest holder taut.



Figure 5: The sewing pattern that attached the sensor holder to the chest strap.

**Conclusions/action items:**

Add these to the poster.

Test the strap.

---

QUINTON HENEY - Dec 02, 2020, 10:36 PM CST



chest\_holder\_pocket.jpg(323.9 KB) - [download](#)

---

QUINTON HENEY - Dec 02, 2020, 10:36 PM CST



chest\_holder\_pocket\_visualized.jpg(261.2 KB) - [download](#)

QUINTON HENEY - Dec 02, 2020, 10:36 PM CST



chest\_holder\_pocket\_and\_sensor.jpg(309.3 KB) - [download](#)

QUINTON HENEY - Dec 02, 2020, 10:36 PM CST



chest\_holder\_full.jpg(88.6 KB) - [download](#)

QUINTON HENEY - Dec 02, 2020, 10:36 PM CST



chest\_holder\_held.jpg(152.7 KB) - [download](#)



chest\_holder\_sewn\_strap\_back.jpg(341.2 KB) - [download](#)



## 9/18/20 - Materials for Design Ideas

---

CASSIDY Geddes - Oct 07, 2020, 1:04 PM CDT

**Title:** Material Ideas for Shoe and Chest Strap Designs

**Date:** 9/18/20

**Content by:** Cassidy Geddes

**Present:** Cassidy Geddes

**Goals:** To find different materials to implement our different design ideas.

**Content:**

- Exercise Band Materials:
  - Fabric Resistance Bands (ex. 55% Latex, 45% Polyester Cotton)
    - This band from Gymshark could be used for both the shoe strap design and the chest strap.
    - It is more of a cloth like material rather than rubber which could be more comfortable on the chest strap.
  - Latex/Rubber Resistance bands
    - These bands have more grip, which would be good to keep the sensors from slipping.
    - They also can be very thin, which could be good for the shoe strap design that goes under the arch of the shoe.
- Materials to go through the holes for shoe laces in The Straps design:
  - Nylon Straps
    - Deals with wear and abrasion well and has high tensile and compressive strength.
    - Lightweight
  - Cotton Straps (ex. trouser blousers)
    - would be strong enough for our purpose, but the cotton can get stretched out more easily.

**Conclusions/action items:**

Continue to research possible materials to use for our different designs. We might need to adjust our designs/materials used once we start testing.

[https://www.gymshark.com/products/gymshark-medium-resistance-band-grey?](https://www.gymshark.com/products/gymshark-medium-resistance-band-grey?gclid=CjwKCAjwzvX7BRAeEiwAsXExo6SbOyPmBpH4KKIjbPexMpMUY0W43ccpMywoloqVUWde32amTX4nhxoC228QAvD_BwE)

[gclid=CjwKCAjwzvX7BRAeEiwAsXExo6SbOyPmBpH4KKIjbPexMpMUY0W43ccpMywoloqVUWde32amTX4nhxoC228QAvD\\_BwE](https://www.gymshark.com/products/gymshark-medium-resistance-band-grey?gclid=CjwKCAjwzvX7BRAeEiwAsXExo6SbOyPmBpH4KKIjbPexMpMUY0W43ccpMywoloqVUWde32amTX4nhxoC228QAvD_BwE)



## 11/09/20 - Rubber Cement

---

CASSIDY Geddes - Dec 09, 2020, 11:30 AM CST

**Title:** Rubber Cement

**Date:** 11/09/20

**Content by:** Cassie Geddes

**Present:** Cassie & Emily

**Goals:** To determine if rubber cement will work as an adhesive in the straps design.

**Content:**

- Rubber cement is commonly used to glue latex sheets together
- Many sources enforce that latex can be bonded together with rubber cement
- Since rubber cement still has a little flex once dried which would help keep the straps design comfortable for the user.

**Conclusions/action items:**

Get rubber cement ordered so that we can use it to make a pocket out of latex on the back of the straps design.

<https://makinglatexclothing.com/2009/01/rubber-cement/>



## 9/17/20 - Playermaker Shoe Strap

CASSIDY Geddes - Oct 07, 2020, 11:17 AM CDT

**Title:** Strap System for Motion Smart Sensor by Playermaker

**Date:** 9/17/20

**Content by:** Cassidy Geddes

**Present:** Cassidy Geddes

**Goals:** To find competing designs for ways to secure motion sensors to the foot of a subject.

**Content:**

- Playermaker has designed a 6-axis motion smart sensor that includes a gyroscope and accelerometer along with a strap system to secure the sensor to the user's cleat.
- The strap system uses a rubber material that wraps around the top and bottom of the user's cleat, securing the sensor to the outside heel of the cleat.
- The sensor provides technical analysis, tactical analysis, physical analysis (distance covered, acceleration/deceleration), as well as gait and load analysis.
- The sensor and strap system is designed to be used while playing soccer/wearing cleats.
- While the strap system is made of a rubber material so is somewhat adjustable, the range of adjustability is not big enough for what Johnson Health Tech is asking for.
- Johnson Health Tech also wants the sensor strapped to the center of the back of the heel, so this design would not work for our application.
- See the design by Playmaker in figure 1 below.

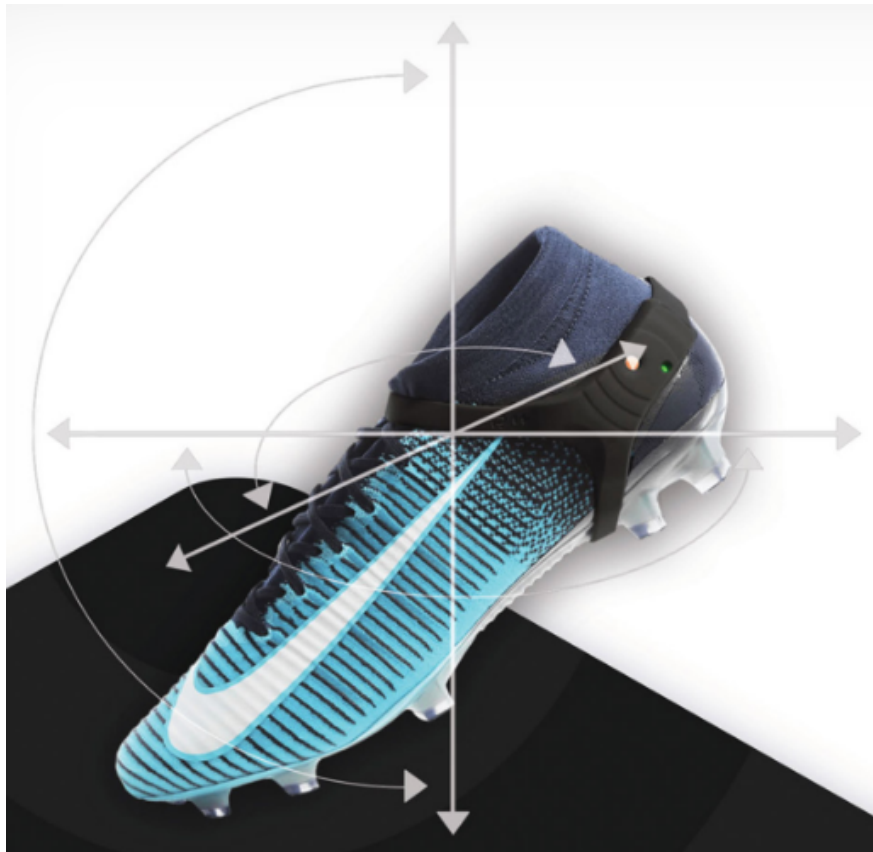

Figure 1: Playermaker's sensor and strap system design seen on a cleat.

**Conclusions/action items:**

Continue to look for competing designs that we could use ideas from to design our strap system for Johnson Health Tech.

Playermaker, "Play Smart. Connect Your Game. ," *Playermaker*. [Online]. Available: <https://playermaker.com/>. [Accessed: 17-Sep-2020].





## 9/17/20 - Xybermind Shoe Strap

CASSIDY Geddes - Oct 07, 2020, 12:10 PM CDT

**Title:** Strap System by Xybermind to hold three sensors to user's ankle region.

**Date:** 9/17/20

**Content by:** Cassidy Geddes

**Present:** Cassidy Geddes

**Goals:** To find more competing designs for the shoe strap.

**Content:**

- Xybermind is a German company that develops small devices for the sport and fitness markets.
- Their design involves an elastic strap lined with fleece, a velcro strap and a cuff. The velcro strap is put over the fleece lined elastic strap to attach the sensors to the ankle region of the user. The cuff is placed above the elastic strap, and it contains an electronic recorder to collect the data.
- This design does not involve attaching any sensors to the back of the heel, which is what our client wants.
- See figure 1 below for the placement of the cuff/electronic recorder and elastic strap/sensors.

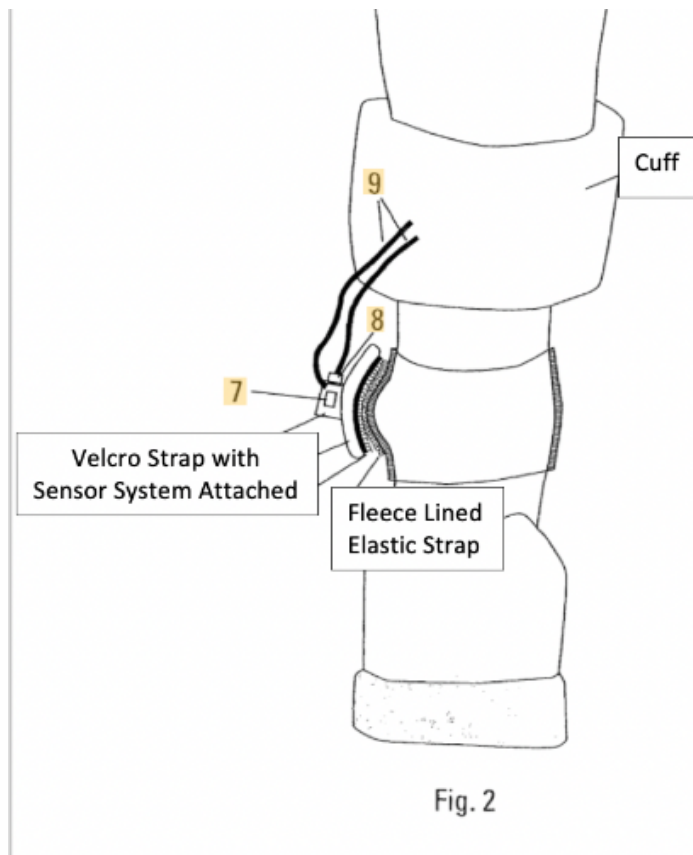

Figure 1: Cuff and elastic strap modeled on the user's ankle region.

**Conclusions/action items:**

Continue to look for competing designs for both the shoe strap system and the chest strap.

R. Feichtinger and J. Löschinger, "Method and Device for Evaluating Displacement Signals," U.S. Patent 7912672B2, Mar. 22, 2011.





## 9/21/20 - Polar Chest Strap

---

CASSIDY Geddes - Oct 07, 2020, 12:21 PM CDT

**Title:** Chest Strap Design by Polar

**Date:** 9/21/20

**Content by:** Cassidy Geddes

**Present:** Cassidy Geddes

**Goals:** To find competing designs for chest straps to secure sensors to the user.

**Content:**

- Polar is a company that specializes in a wide range of sports training computers.
- They have multiple different heart rate monitors that can be worn as chest straps, and each chest strap design is the same in that it is a loop that goes around the user's chest.
- The strap design uses a soft textile material with silicone dots. The soft material makes it more comfortable for the user, and the silicone dots prevent the strap from slipping. The strap is secured with a buckle in the back.
- Since these are heart rate monitors they have to be in direct contact with the user's skin, but Johnson Health Tech has not mentioned anything about this being a specification for the chest strap we design, since the sensor being attached is being used for its accelerometer capabilities.

**Conclusions/action items:**

Come up with other chest strap designs that we can use for our design. Start looking at materials we could use for our chest strap system.

Polar Global, "Heart Rate Sensors," 2020. [Online]. Available: <https://www.polar.com/en/products/heart-rate-sensors>. [Accessed: 05-Oct-2020].



## 10/5/20 - Johnson Health Tech Current Shoe Strap

CASSIDY Geddes - Oct 07, 2020, 12:32 PM CDT

**Title:** Shoe Strap Design that Johnson Health Tech is Currently Using

**Date:** 10/5/20

**Content by:** Cassidy Geddes

**Present:** Cassidy Geddes

**Goals:** To learn about the current design used by Johnson Health Tech in order to understand what aspects need to be improved.

**Content:**

- The current method that Johnson Health Tech uses to secure the sensor to the center of the user's heel involves using athletic tape.
- The sensor is secured to the back of the user's shoe using athletic tape and then it is wrapped more in tape that goes over the laces of the shoe and under the sole.
- This method is time consuming and the sensor easily slips during testing
- The tape also tends to roll up, which affects the gait of the user in turn messing up the results collected.
- See figure 1 to understand how the sensor is secured.



Figure 1: Current design used by Johnson Health Tech.

**Conclusions/action items:**

Work as a team to come up with better designs that meet the requirements of Johnson Health Tech.



## Trigno Avanti Sensor

CASSIDY Geddes - Oct 07, 2020, 10:01 AM CDT

**Title:** Trigno Avanti Sensor

**Date:** 9/14/20

**Content by:** Cassidy Geddes

**Present:** Cassidy Geddes

**Goals:** To learn more about the sensors that our client wants us to use and build straps for.

**Content:**

### Trigno Avanti Sensor

- wireless sensor that has EMG and IMU capabilities
  - Will be used by Johnson Health Tech for accelerometer purposes
- it has research and mobile data collection modes
- selectable EMG bandwidth settings
- signal processing in sensor
- wireless communication that works best on Windows PC or Android devices
- Size: 37x37x13 mm
- Mass = 14g
- Maximum Accelerometer Sampling Rate = 963 sa/sec
- Sensor Resolution = 16 bits
- ACC/Gyro Analog Output Delay = 96 ms (fixed)
  - This could be helpful to know when taking tests using our different fabricated models.
- The sensor is made if medical grade polycarbonate

### Conclusions/action items:

The information about the size and programming details will be helpful when designing the different strap systems and for testing how each design we build affects the user's gait. It will be important to look up what information the sensor sends to the computer and how we plan on analyzing it in MATLAB.

Delsys Incorporated, "Trigno® Wireless Biofeedback System User's Guide," Trigno Wireless Biofeedback System User's Guide, Feb-2020. [Online]. Available: <https://delsys.com/downloads/USERSGUIDE/trigno/wireless-biofeedback-system.pdf>. [Accessed: 06-Oct-2020].



# 09/17/2020 - Shoe Strap

CASSIDY Geddes - Oct 06, 2020, 11:45 PM CDT

**Title:** Shoe Strap Design Idea

**Date:** 9/17/2020

**Content by:** Cassidy Geddes

**Present:** Cassidy Geddes

**Goals:** To come up with a design to secure the sensor given to us by our client to the heel of the user's shoe. It also needs to follow the design specifications given to us by our client.

**Content:**



**Conclusions/action items:**

Meet as a team to decide the three best designs and create the design matrix. It might be beneficial to combine some of the designs we come up with. Start researching what materials to use for this design as well as the designs we decide on for our design matrix.



## 10/6/20 - COE Permits

CASSIDY Geddes - Oct 06, 2020, 11:56 PM CDT

**Title:** Green and Red Permits

**Date:** 10/6/20

**Content by:** Cassidy Geddes

**Present:** Cassidy Geddes

**Goals:** Show that I have a valid green pass and red pass.

**Content:**





**Conclusions/action items:**

Use these permits if we are allowed to/if any of the designs require it for fabrication.





## 2014/11/03-Entry guidelines

---

John Puccinelli - Sep 05, 2016, 1:18 PM CDT

Use this as a guide for every entry

- Every text entry of your notebook should have the **bold titles** below.
- Every page/entry should be **named starting with the date** of the entry's first creation/activity, subsequent material from future dates can be added later.

You can create a copy of the blank template by first opening the desired folder, clicking on "New", selecting "Copy Existing Page...", and then select "2014/11/03-Template")

**Title:** Descriptive title (i.e. Client Meeting)

**Date:** 9/5/2016

**Content by:** The one person who wrote the content

**Present:** Names of those present if more than just you (not necessary for individual work)

**Goals:** Establish clear goals for all text entries (meetings, individual work, etc.).

**Content:**

Contains clear and organized notes (also includes any references used)

**Conclusions/action items:**

Recap only the most significant findings and/or action items resulting from the entry.



**Title:**

**Date:**

**Content by:**

**Present:**

**Goals:**

**Content:**

**Conclusions/action items:**