

# BME Design-Fall 2020 - EMMA NEUMANN

## Complete Notebook

PDF Version generated by

GABRIELLE SNYDER

on

Dec 09, 2020 @06:28 PM CST

## Table of Contents

Project Information	2
Team contact Information	2
Project description	3
Team activities	4
Client Meetings	4
Initial Client Meeting	4
Hospital Visit Notes	6
Client Questions and Answers (11.2.20)	7
Advisor Meetings	8
Meeting with Dr. Nimunkar	8
Design Process	9
9/27/2020 - Preliminary Design Matrices	9
Materials and Expenses	10
Materials	10
Final Design Components	11
Final Design Illustration	13
Testing and Results	14
Protocols	14
Testing Ideas	14
Project Files	15
Link to Project Description	15
10/1/2020 Preliminary Design Presentation	16
PDS	17
Preliminary Report	21
Final Poster and Presentation	37
Final Report	38
Emma Neumann	39
Research Notes	39
Biology and Physiology	39
The Cardiac Cycle and Heart Sounds	39
Heart Sounds Video	42
Competing Designs	43
SimMan 3G	43
Standards	44
FDA Labeling Requirements	44
INACSL Standards	45
Design Ideas	47
Vest Ideas	47
10/6/2020 Breast Plate Solidworks	47
9/23/2020 Initial Design Ideas	48
10/6/2020 Heart and Lung Sounds Library	49
Circuitry	50
Adafruit Audio FX Sound Board	50
DROK Bluetooth Audio Receiver	51
Training Documentation	52
Red Permit	52

Biosafety Training .....	54
Gabby Snyder .....	55
Research Notes .....	55
Biology and Physiology .....	55
Abnormal Heart Rhythms .....	55
How the Heart Works .....	57
Sterilizable Materials .....	60
Sterilizable Plastics .....	61
Competing Designs .....	62
General Manikin Research .....	62
Design Ideas .....	63
Idea #1 .....	63
Idea #2 .....	64
Sim Lab Manikin Photos .....	65
Block Diagrams for Prelim Designs .....	68
Heart/Lung Sound Software .....	69
Potential Speakers for Our Design .....	70
Ideas for Potential Vests .....	72
Theoretical Final Design .....	74
Training Documentation .....	75
Green Permit .....	75
BioSafety Training Cert .....	76
Rushabh Tolia .....	77
Research Notes .....	77
Biology and Physiology .....	77
10/04/20 Heart Rhythms and Signals .....	77
10/05/20 Lung Sounds and Irregular Breathings .....	79
Competing Designs .....	81
09/18/20 Lateral SimMan 3G .....	81
09/23/20 Fidelity Simulator Requirements .....	83
Design Ideas .....	85
09/23/20 Design Ideas for Design Matrix .....	85
10/04/20 Circuitry Designs for Heart Functions .....	86
10/07/2020 Circuitry for Lung and Heart Sounds .....	88
Circuitry .....	91
2020/12/08- Arudino Uno Soundboard Multiple Design .....	91
2020/12/08- Arduino Uno .....	93
11/30/20 Circuit Adafruit design .....	96
11/30/20 Adafruit Speaker Details .....	97
Training Documentation .....	100
Red Pass .....	100
Caroline Gervolino .....	101
Meeting Notes .....	101
Meeting #1 .....	101
Meeting #2 .....	102
Research Notes .....	103
9/9/20 Research of Medical Mannequins for Education .....	103
9/7/20 Basic Outline of the Project .....	104
9/17/20 Simple Simon Patient Care Manikin .....	105
9/17/20 Simulaids SMART STAT Basic with iPad Research .....	107
10/23/2020 Audio Libraries .....	109
Design Ideas .....	110
9/23/20 Initial Design Idea .....	110
Elijah McCoy .....	111
Research Notes .....	111
Biology and Physiology .....	111
10/6/20 Heart and Lung Sounds Reference Guide .....	111
Competing Designs .....	112
9/17/20 Research of S-Vest .....	112
Design Ideas .....	113
9/22/20 Design Idea .....	113

10/23/20 Research on speakers .....	116
10/29/20 Adafruit .....	118
11/12/20 Vest Research .....	119
Tim Tran .....	120
Research Notes .....	120
Biology and Physiology .....	120
Most Common Lung Problems .....	120
Acoustic Methods for Pulmonary Diagnosis .....	122
Heart and Lungs Sound Library .....	124
Tips for running wire through garments .....	125
Design Ideas .....	126
Initial design ideas .....	126
2014/11/03-Entry guidelines .....	127
2014/11/03-Template .....	128



## Team contact Information

EMMA NEUMANN - Sep 11, 2020, 12:23 PM CDT

Last Name	First Name	Role	E-mail	Phone	Office Room/Building
Bersu	Ed	Advisor	etbersu@wisc.edu	608-890-5641	
Michael	Lomeier	Client	mtlohmei@medicine.wisc.edu		
Emma	Neumann	Leader	ekneumann@wisc.edu	608-206-2721	
Gabby	Snyder	Communicator	gesnyder@wisc.edu	630-853-4672	
McCoy	Elijah	BSAC	epmccoy@wis.edu	630-870-2655	
Tolia	Rushabh	BWIG	rtolia@wisc.edu	630-518-0114	
Gervolino	Caroline	BPAG	gervolino@wisc.edu	201-679-3651	
Tran	Tim	BPAG	ttran28@wisc.edu	608-207-6640	



## Project description

---

RUSHABH TOLIA - Sep 09, 2020, 8:28 PM CDT

**Course Number:** 70420

**Project Name:**

*Wearable Simulator for Enhanced Realism*

**Short Name:**

Wearable Simulator

**Project description/problem statement:**

Simulations have become a prominent tool in the medical industry to train students and staff in a safe environment on infrequent and risky scenarios. However, mannequins remain inanimate objects that can be hard to interact with in a realistic way. This project aims to create a wearable simulation vest that a human could wear to create a more realistic interpretation of these events. The vest would be equipped with audible and electrical body function simulators able to be manipulated and detected for different scenarios similar to mannequin simulators. The vest wearer would then be able to more accurately act out scenarios and interact with the medical students and staff to better portray specific medical conditions, emotions, and body positions.

**About the client:**

Dr. Michael Lohmeier, MD, is the medical director at Sun Prairie & Waunakee EMS, the medical director of UW Health Emergency Education Center and an associate professor. He joined the faculty in the Department of Emergency Medicine at the UW school of Medicine and Public Health after completing his emergency medicine residency training that the Washington University School of Medicine in Saint Louis, serving as chief resident in his fourth year. Afterwards, he completed his fellowship in emergency services at Washington University with a concentration in tactical medicine. He has areas of interest in EMS and prehospital care, where his research interests currently lie, mass casualty preparedness, fireground rehab and resident education.

Source: "Michael Lohmeier, MD." *Michael Lohmeier, MD | Emergency Medicine*, [www.emed.wisc.edu/michael-lohmeier-md](http://www.emed.wisc.edu/michael-lohmeier-md).



## Initial Client Meeting

---

GABRIELLE SNYDER - Sep 15, 2020, 7:17 PM CDT

**Title:** First Client Meeting

**Date:** 9/11/20

**Content by:** Gabby

**Present:** Gabby, Emma, Tim, Elijah, Caroline

**Goals:** To meet our client and ask him questions to get a better understanding of the project

**Content:**

Questions for Client:

- What will our funding be for the project?
  - \$500 currently
  - possibly more from a grant
    - he will talk to his colleagues to figure out more information about obtaining a grant
- What specifically do you want our simulator to be different from those available in the marketplace?
  - Mainly that it will just be something the an actual person can wear
  - "has the guts" of a SimMan but just in something wearable (ie a vest)
  - someone could wear it so the person practicing with the mannequin is looking at/working with a person and not a plastic thing
- What are the most important aspects of current mannequins that you would like us to work on implementing into our vest design this semester?
  - Heart sounds and pulses → speaker system
    - many other things that could always be added in the future
    - Possibly 3 lead & 4 lead heart
    - Taking sim man guts and putting them in vest
    - some sim mans have display monitors showing heart rates but Dr. Lohmeier said the sounds would be more important than a display
  - Have current simulators with monitors that we could hook up to the vest
- Are there any specific scenarios that we should focus on creating first? Ie cardiac arrest, surgery
- Are there any size or weight restrictions for the design of the vest?
  - For someone with average size and build
  - client, Dr. Lohmeier would probably be the one wearing it and he is a 6ft and 185lb male
  - Not super heavy or bulky
    - Kevlar vest weight
- "this "sim-vest" would be controlled by a second operator at a separate workstation who could manipulate the breath sounds...etc" **will the vest be able to simulate conditions by itself or would it require someone else to control it at all times?**

- Would be ideal if there was a second person who could change the conditions of the vest
- person wearing it ideally should not be the one controlling the vest
- How often would the vest be used? Daily?
  - Simulations 1 day per week
  - 4-5 times per month

**Conclusions/action items:**

After talking with Dr. Lohmeier as a team we will create the first draft of the PDS. We will continue our research on different topics related to this design. Additionally, Dr. Lohmeier contacted the simulation lab, and they responded that our team would be able to visit the lab at some point and get to see the mannequins they use. Therefore, we need to figure out a time that works for us as a team, and then I (Gabby) will communicate with the lab members to establish a day and time for us to meet. Lastly, everyone should start coming up with preliminary design ideas.



## Hospital Visit Notes

EMMA NEUMANN - Oct 05, 2020, 2:06 PM CDT

Title: Hospital Visit Notes

Date: 10/5/2020

Created by: Emma Neumann

Present: Emma, Gabby, Caroline, Tim

Goal: See what simulations are currently in use and talk with Mike about what we are thinking about for the design.

Content:

\*some hand written notes are below\*

Conclusion:

Mike was happy with where we are at and fully supports our decision to go with a vest and wireless speaker system. He wants us to just focus on integrating speakers to start.

EMMA NEUMANN - Oct 05, 2020, 2:03 PM CDT

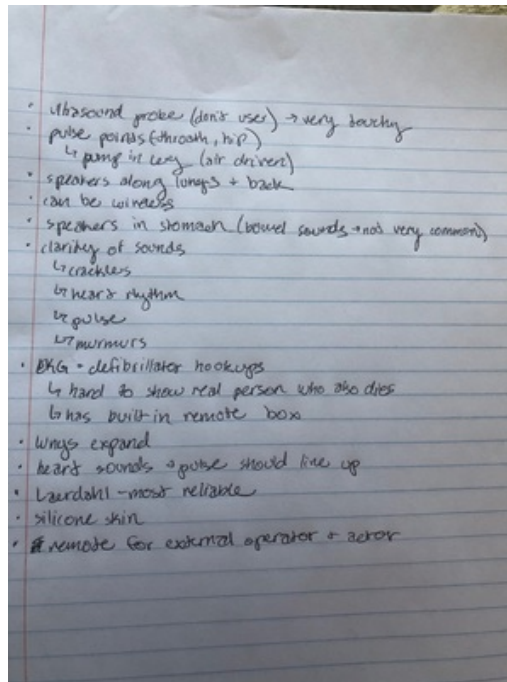

175BDCD3-09A7-45D6-8853-1565DE50A571.jpg(502.7 KB) - [download](#)





## Client Questions and Answers (11.2.20)

GABRIELLE SNYDER - Nov 05, 2020, 3:34 PM CST

**Title:** Client Questions and Answers

**Date:** 11.2.20

**Content by:** Gabby

**Present:** whole team as this took place through email

**Goals:** To ask Dr. Lohmeier questions regarding our current design ideas and have him provide us some feedback

**Content**

### Question 1:

**- is there any specific number of heart and lung sounds that you would like us to incorporate into the vest? i.e. Are there main sounds you use more regularly than others?**

- In addition to "normal" heart sounds and "normal" lung sounds, we frequently use several "abnormals" for each
  - Heart -
    - tachycardia (fast)
    - bradycardia (slow)
    - systolic murmurs (sound when blood pushing forward)
    - diastolic murmurs (sound when heart relaxing)
    - total: 5 sounds
  - Lung
    - wheezing
    - rales
    - rhonchi
    - NO sound are probably the mainstays
    - total: 5 sounds
    - In addition, it's fairly common that we will have asymmetric breath sounds (i.e. normal on one side and absent on the other to simulate pneumothorax, or normal on one side and rales on the other to simulate aspirated foreign body)

### Question 2:

**-Are the lung sounds produced on the front right side of the body the same as the lung sounds produced on the back right side of the body? And the same thing for the front and back lung sounds on the left side of the body?**

- If I understand your question correctly, yes, the sounds in the front and back should be the same
- As above, though, there may be right-to-left differences in sounds for some clinical scenarios (i.e. pneumothorax)

### Question 3:

**- We are currently planning on incorporating 5 speakers into the vest design: 2 for lung sounds produced on the front right and left sides of a person, 2 for lung sounds produced on the back right and left sides, and 1 for heart sounds. Do this make sense with you?**

- I think the plan for 5 speakers sounds like a great plan!

### **Conclusions/action items:**

Dr. Lohmeier was very helpful with his responses, and it seems we are on the right track design-wise. It looks like we are going to need a total of 5 heart sounds and 5 lung sounds. Dr. Lohmeier also like the idea of having 5 speakers with is good. Now as a team we need to finalize our materials list and then actually order them. I, Gabby, will also need to ask Dr. Lohmeier what would be the best way to go about purchasing materials and being reimbursed.



## Meeting with Dr. Nimunkar

GABRIELLE SNYDER - Oct 26, 2020, 11:55 AM CDT

**Title:** Meeting with Dr. Nimunkar on Circuitry

**Date:** 10.26.20

**Content by:** Gabby

**Present:** Emma, Rushabh, Elijah, and Caroline

**Goals:** To talk with Dr. Nimunkar to get some ideas on what kinds of circuitry we should use to produce the heart and lung sounds for our vest design

**Content:**

- idea 1: buy a cell phone
  - make an app and put the sounds in the app
  - place phone in the vest as the source of the sound
  - issue: we want 4 speakers
    - 2 on front and 2 in back
    - phone would only be one speaker
- requirements
  - 4 locations with 4 sounds/volumes/amplitudes --> these controlled by a second person/ a moderator
  - 4 lung sounds: 2 on left side of body match up (one on front & one on back)
    - 2 on right side of body match up (one on front & other on back)
    - thinking: 1 file with both sounds and amplitude
  - 1 heart sounds, 1 heart rate, 1 amplitude --> 1 file
- could a phone "talk to" (hook up to) 4 different speakers?
  - Samsung, Bluetooth 5, can connect to 2 different Bluetooth speakers at once
    - could get 2 different sounds but not four
- maybe look at a web interface to connect to 4 devices
- idea 2: **raspberry pi (0)**
  - wireless communication ?
  - connect to wifi
  - it has its own SD card
  - web interface
    - moderator can choose which file goes to which speaker
    - could hook up the raspberry pi to 4/5 speakers
  - play multiple sounds simultaneously with a Raspberry Pi
    - <https://www.raspberrypi.org/blog/multiple-sounds-simultaneously-raspberry-pi/>
      - another link off the above site giving more details on what the person did to create this device for generating multiple sounds at the same time- <http://www.esologic.com/multi-audio/>
  - since we have a fairly large budget, we could buy multiple raspberry pi s in order to split team up into a 2 or 3 groups to work on the code
    - would give us multiple iterations
    - would also give everyone a chance to work with the code (python) and with the raspberry pi
- Dr. Nimunkar also mentioned we could contact Madison from the sensor yoga mat design project for information on how to use/program a raspberry pi

**Conclusions/action items:**

After meeting with Dr. Nimunkar we, as team, currently believe the going with the raspberry pi as device for interacting with the different speakers would be the best idea. So going forward we need to order at least one, maybe two raspberry pi 's, for our team to start working with. We also need to figure out what kind of speakers we should buy to connect to the raspberry pi and insert into our vest. Also, the code may be somewhat challenging in order for it accomplish all we want it too so breaking up into a least two groups may be a good idea.



# 9/27/2020 - Preliminary Design Matrices

EMMA NEUMANN - Sep 27, 2020, 2:41

**Title: Preliminary Design Matrices**

**Date:** 9/27/2020

**Content by:** Emma Neumann

**Present:** Emma, Gabby, Tim, Elijah, Caroline

**Goals:** Decide on a preliminary final design

**Content:**

Criteria	Weight	breast plate	long sleeves	vest	
Adaptability/Fidelity	30	1	5	4	ability to add more components to the vest, ability for the vest to produce many different sounds, pulses, and addition
Ease of Manufacturing	20	5	1	3	
Comfort	15	4	3	4	the material and weight of the device should be able to be worn for long periods of time
Sterilizability	15	4	1	4	ability to be sterilized in between uses
Cost	15	5	2	3	
Safety	5	5	5	5	how easy can someone take off the vest in case something goes wrong?
<b>Total</b>	<b>100</b>	<b>70</b>	<b>57</b>	<b>74</b>	

Criteria	Weight	speaker wireless	speaker dial con	ac generator	
Ease of Manufacturing	25	2	4	1	The circuitry complexity or machine needed for signal or electrical analysis.
Safety	20	5	4	2	will it electrocute you
Accuracy of Output	15	4	4	5	How well the output of the signal corresponds to an individual experiencing similar conditions.
Adaptability	15	4	2	3	can additional scenarios and hardware be added to it
Motility	15	5	3	1	ability to remove the circuitry, move it around the vest, and whether it can be remotely controlled
Cost	10	4	3	1	
<b>Total</b>	<b>100</b>	<b>77</b>	<b>69</b>	<b>42</b>	

- breast plate: plastic capsule for electronics on front, adjustable fabric straps
- long sleeve: one-piece, wires up neck and arms, zipper down front
- vest: buckles for adjustability
- speaker wireless: only speakers for heart and lung sounds, bluetooth enabled or app
- speaker dial controlled: only speakers for heart and lung sounds, pocket w/ remote control attached to vest
- ac generator: speakers and electrical waves for heart and lung, need amplifier and generator, AC plugin

breast plate pictures under Gabby's designs  
 long sleeve pictures under Emma's designs  
 vest is a combination of all our designs

**Conclusions/action items:**

- create preliminary design presentation
- create solidworks figures of each garment and block diagram for each electronic design
- get design approved by advisor



Item	Item	Number	Total	Link
Adafruit Sound Board (16MB)	29.95	3	89.85	<a href="https://www.digikey.com/en/products/detail/adafruit-industries-llc/2217/5761278">https://www.digikey.com/en/products/detail/adafruit-industries-llc/2217/5761278</a>
Adafruit Amplifier	3.95	3	11.85	<a href="https://www.adafruit.com/product/2130">https://www.adafruit.com/product/2130</a>
Speakers	1.95	5	9.75	<a href="https://www.adafruit.com/product/1890">https://www.adafruit.com/product/1890</a>
Raspberry Pi zero w	10	1	10	<a href="https://www.adafruit.com/product/3400">https://www.adafruit.com/product/3400</a>
Battery Pack (3-5.5 VDC)	1.6	4	6.4	<a href="https://www.dfrobot.com/product-1130.html?gclid=CjwKCAiAkan9BRAqEiwAP9X6UUaiVDijq7mkZ6gkOfW8repf1YxMTV27jJaFA364mGVgIB">https://www.dfrobot.com/product-1130.html?gclid=CjwKCAiAkan9BRAqEiwAP9X6UUaiVDijq7mkZ6gkOfW8repf1YxMTV27jJaFA364mGVgIB</a>
AA batteries (24 pack)	16.21	1	16.21	<a href="https://www.amazon.com/Duracell-CopperTop-Batteries-all-purpose-household/dp/B0035LCFNQ/ref=asc_df_B0035LCFNQ/?tag=hyprod-20&amp;linkCode=df0&amp;hvadid=295941034974&amp;hvpos=&amp;hvnetw=g&amp;hvrand=2539491115643693835&amp;hvpone=&amp;hvptwo=&amp;hvqmt=&amp;hvdev=c&amp;hvdv425062943033&amp;pvc=1">https://www.amazon.com/Duracell-CopperTop-Batteries-all-purpose-household/dp/B0035LCFNQ/ref=asc_df_B0035LCFNQ/?tag=hyprod-20&amp;linkCode=df0&amp;hvadid=295941034974&amp;hvpos=&amp;hvnetw=g&amp;hvrand=2539491115643693835&amp;hvpone=&amp;hvptwo=&amp;hvqmt=&amp;hvdev=c&amp;hvdv425062943033&amp;pvc=1</a>
			144.06	



# Final Design Components

GABRIELLE SNYDER - Dec 08, 2020, 4:50 PM CST

**Title:** Some Design Components

**Date:** 12.8.20

**Content by:** Gabby (with help of Emma and rest of team)

**Present:** team

**Goals:** To illustrate some of the design components we ordered and their role in the design.

**Content:**

design components

1. *Adafruit Soundboard.*

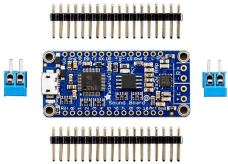

~The soundboard is used to store the sounds and easily switch between different sounds

2. Raspberry Pi Zero

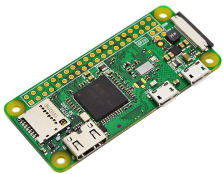

~The Raspberry Pi controls the sounds boards and which sounds are being played by each speaker and allows for controller input.

3. Speaker



Speakers will be placed around the vest to produce the heart and lung sounds.

4. Weight Vest



This weight vest features pockets for easy placement of speakers close to desired position and adjustable sides due to flexible cords.

link: [https://www.roguefitness.com/hyper-vest-elite-weight-vest?160=3529&287=3581&gclid=CjwKCAiA8Jf-BRB-EiwAWDtEGuU2LEooie-NRG\\_3MOTCp2Tq8ohTWPt-dAy-Rfdv\\_CFXsTwtcae8CRoCuW0QAvD\\_BwE](https://www.roguefitness.com/hyper-vest-elite-weight-vest?160=3529&287=3581&gclid=CjwKCAiA8Jf-BRB-EiwAWDtEGuU2LEooie-NRG_3MOTCp2Tq8ohTWPt-dAy-Rfdv_CFXsTwtcae8CRoCuW0QAvD_BwE)

**Conclusions/action items:**

Our materials unfortunately arrived too late this semester in order for use to begin any kind of fabrication. Hopefully, some of us will be able to continue this project next semester, allowing us the opportunity to begin fabrication right at the beginning of the semester.

# Final Design Illustration

GABRIELLE SNYDER - Dec 08, 2020, 4:41 PM CST

**Title:** Final Design Illustration

**Date:** 12.2.20

**Content by:** illustration by Gabby and Emma. Rest of team helped with certain aspects of the description

**Present:** team was present (Gabby and Emma created the illustration)

**Goals:** To create a drawing of what we would have attempted to fabricate this semester, given different circumstances.

**Content:**

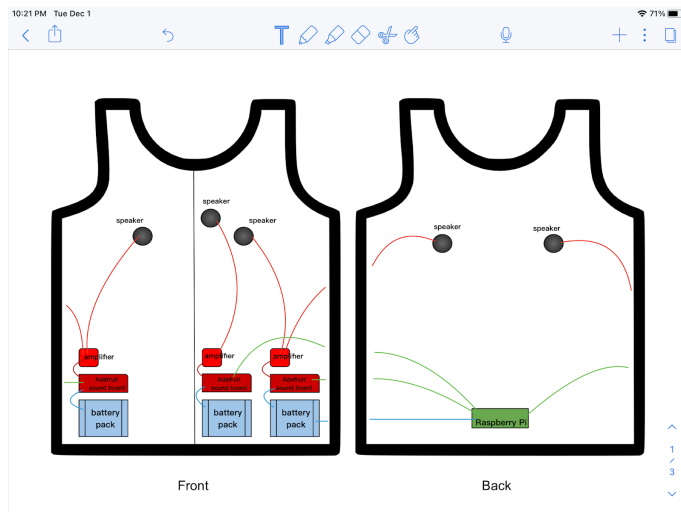

- all of the electronic components would be placed within the pockets that the vest would come with
  - we could add holes and then sew them back up
- in theory, the wires connecting the components would be run between the layers of the vest
  - want to avoid wires hanging off of the vest because these could get in the way and become a safety hazard
- In our design we placed the raspberry pi on the back of the vest
  - to avoid having to run wires all around the zipper
  - figured that putting the raspberry pi on the back would better allow the wires coming from it to connect to the adafruit sound boards
- the raspberry pi sends the signal to the sound boards and "tells" them which heart/lung sound should be produced
- the sound boards (powered by the battery packs) then send the signal through the amplifier, which helps make sure the sound that is produced sounds okay
- then, the sound is emitted from the vest via the speakers
  - the speaker located on the middle front of the vest produces the heart sound
  - the other 4 speakers produce lung sounds
    - left/right side of body and front/back side of body
- the person acting out the specific simulation would wear our vest with the electronic components
- additional ideas:
  - we may need to move the raspberry pi to the front of the vest if it is uncomfortable to the wearer located on the back side
  - we could 3D print smaller plastic "containers" that we could place our electronic components inside of in order to protect them during the simulations and prevent them from getting damaged

## Conclusions/action items:

Hopefully, next semester Emma and I (Gabby), possibly others, will be able to continue with this project and actually be able to fabricate our ideas to create a working design. All of the materials we ordered with the hope of being able to fabricate something before final presentations have arrived. Therefore, next semester we would be able to start right away with fabrication.

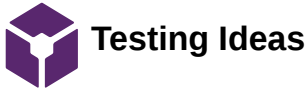

GABRIELLE SNYDER - Dec 08, 2020, 4:01 PM CST

**Title:** Testing Ideas

**Date:** 12.2.20

**Content by:** Gabby (the content was written by for our presentation Emma, I am just putting what Emma wrote into our notebook)

**Present:** team

**Goals:** To come up with ideas of how we would test our design if we had had the materials and time for fabrication.

**Content:**

Due to COVID and our materials not arriving on time we were never able to actually fabricate our ideas for the design. As a result, we were unable to perform any testing since we had no design to test. However, we did come up with some ideas for that type of testing we would have performed

1. Functioning Circuitry

1. Run code without errors
2. Play different sounds on different speakers at once
3. Speakers output sounds

2. Sound Accuracy

1. Be able to identify heart and lung sounds
2. Be able to locate the heart and lung sounds
3. Be able to differentiate the sounds from each speaker

3. Ability to Manipulate and Interact

1. Controller can change the sound outputs of each individual speaker
2. Quantify the time it takes from command to output

4. Vest

1. Comfortable for extended periods of time
2. Adjusts to different body types

5. Statistical Analysis

1. Null Hypothesis: The multimeter will detect no difference from output of speaker to actual heart sounds, will measure mean amplitude and use 1-sample T-test.
2. Alternative Hypothesis: The multimeter has detected a difference from the output of the speaker to a heart.

**Conclusions/action items:**

These are our initial ideas for testing our design. Some ideas may need to be edited, added, or removed when/if we actually ever get to do testing on the design.





## Link to Project Description

---

RUSHABH TOLIA - Sep 09, 2020, 8:05 PM CDT

<https://bmedesign.engr.wisc.edu/selection/projects/bb3bbfa9-9dee-42f9-97f8-46e7d19a7421>



# 10/1/2020 Preliminary Design Presentation

EMMA NEUMANN - Oct 06, 2020, 10:58 PM CDT

**Title:** Preliminary Design Presentation

**Date:** 10/1/2020

**Content by:** Emma, Gabby, Rushabh, Tim, Elijah, Caroline

**Present:** Emma, Gabby, Rushabh, Tim, Elijah, Caroline

**Goals:** Present our preliminary designs to our advisor and client to get feedback.

**Content:**

slides are linked below

video: [https://drive.google.com/file/d/1YwJlgyPfyKMKXHofQyJTz\\_Nv5SWpvhmZ/view?usp=sharing](https://drive.google.com/file/d/1YwJlgyPfyKMKXHofQyJTz_Nv5SWpvhmZ/view?usp=sharing)

**Conclusions/action items:**

finish the preliminary report

EMMA NEUMANN - Oct 06, 2020, 10:55 PM CDT



[Preliminary\\_Design\\_Presentation\\_Slides.pdf\(2 MB\) - download](#)

EMMA NEUMANN - Oct 06, 2020, 10:59 PM CDT



[Preliminary\\_Design\\_Presentation.mp4\(47.8 MB\) - download](#)



# Product Design Specifications

*Wearable Simulator for Enhanced Realism*

Updated: 10/7/2020

Client: Dr. Michael Lohmeier [mtlohmei@medicine.wisc.edu](mailto:mtlohmei@medicine.wisc.edu)

Advisor: Dr. Ed Bersu [etbersu@wisc.edu](mailto:etbersu@wisc.edu)

Team: Emma Neumann [ekneumann@wisc.edu](mailto:ekneumann@wisc.edu) (Leader)

Gabby Snyder [gesnyder@wisc.edu](mailto:gesnyder@wisc.edu) (Communicator)

Rushabh Tolia [rtolia@wisc.edu](mailto:rtolia@wisc.edu) (BWIG)

Elijah McCoy [epmccoy@wisc.edu](mailto:epmccoy@wisc.edu) (BSAC)

Caroline Gervolino [gervolino@wisc.edu](mailto:gervolino@wisc.edu) (Co-BPAG)

Tim Tran [ttran28@wisc.edu](mailto:ttran28@wisc.edu) (Co-BPAG)

## Function:

Simulations have become a prominent tool in the medical industry to train students and staff in a safe environment on infrequent and risky scenarios. However, mannequins remain inanimate objects that can be hard to interact with in a realistic way. This project aims to create a wearable simulation vest that a human could wear to create a more realistic interpretation of these events. The vest would be equipped with audible and electrical body function simulators able to be manipulated and detected for different scenarios similar to mannequin simulators. The vest wearer would then be able to more accurately act out scenarios and interact with the medical students and staff to better portray specific medical conditions, emotions, and body positions.

## Client requirements:

- No more than \$500
- Must be a wearable simulator of reasonable weight and size to fit the average person
- Can be used 4-5 times a month
- Outputs can be modified during simulation to respond to interventions
- Simulates heart sounds and pulses
- Simulates lung sounds

## Design requirements:

### 1. Physical and Operational Characteristics

1. *Performance Requirements:* This design should be something that can be worn comfortably on the upper body of a person and can produce varied heart sounds and pulses. It should be able to be used about four to five times a month and able withstand the force exerted by the user each time. The device should also be adjustable to fit the various builds of the user.

2. *Safety*: This product will contain electrical equipment that will be properly enclosed, grounded, and equipped with a kill switch. The edges of the vest will be soft and rounded to prevent injury, and it will be designed to keep as full of a range of motion as possible. Anyone wearing the vest, will need to be trained on how to properly use it. Proper labeling on the vest will warn users of the electrical components present and the thermal risk of wearing the vest for extended periods of time to avoid overheating. There will also be a disclaimer reminding users that the vest is a simulation of medical conditions, but does not perfectly mimic all conditions or all aspects of those conditions. All labeling will adhere to FDA Labeling Regulatory Requirements for Medical Devices [1].
3. *Accuracy and Reliability*: This product will have two components, the wearable vest component and the electronic components. The vest will be built with strong materials so that it is reliable, accurate, and will not rip or break when worn by an actor of the correct size. The electronic portion will be based on current simulator technology. With high quality technology installed in the vest, it should be able to produce reliable results almost every time.
4. *Life in Service*: This product will be made of sturdy materials similar to those in a kevlar vest, which uses sail cloth and polyethylene fibers [2]. With these strong materials and the vest being used about 8-12 hours a week, the vest should be able to be worn for multiple years in a medical education setting before needing to be replaced or repaired. The vest simulator will also have an electronic component for measurements including heart sounds, pulse, and a speaker system, These features will be similar to the technology used in the current simulators and mannequins, which have been used in medical practice for many years, and have proven to be durable and provide accurate information.
5. *Shelf Life*: The vest itself will mostly be made from polyethylene fibers, which has an indefinite longevity [3]. The batteries for the electronics, that will be needed to moderate the heart and breathing sounds, will need to be changed/charged once every few months depending on usage, which is the only potential corrosive aspect of the device.
6. *Operating Environment*: The device will mostly be used by EMTs and medical students as a training model for real-life patients. The training with the device will mostly occur in special simulator training areas. The device will need outlets and a table for the electronic kits included with the vest and will require an environment that has no contact with any aqueous solutions.
7. *Ergonomics*: The vest itself will be easily portable with the various electronic kits that will be sized into a well balanced tool kit. The vest itself will be reasonably weighted and sized to avoid weighing down the user and to maintain as much range of motion as possible.
8. *Size*: The design for this product should be created to be comfortably worn by a 6ft, 185lb male. It should not be overly heavy and bulky or restrict movement of the waist, shoulders, and neck.
9. *Weight*: This product will be worn by actors for potentially long periods of time; therefore, to maximize comfort and functionality, the vest, including the electrical components, will be a maximum of 5-6 pounds, similar to the weight of a kevlar vest [4].
10. *Materials*: For a balance between strength, weight, comfort, and affordability, the vest will be made out of canvas and strong fibers such as polyethylene and sail cloth [3].
11. *Aesthetics, Appearance, and Finish*: It is important that there are no sharp edges on the design and that the material chosen does not cause excess irritation or pain to the skin. There should be no loose wires or anything sticking out. The device should be pleasing to look at and all parts should be attached cleanly.

## 2. Production Characteristics

1. *Quantity*: A single prototype vest will be created. Ideally more vests would be created and at a lower cost in the future.
2. *Target Product Cost*: There is an initial budget of no more than \$500, but if more money is needed Dr. Lohmeier can be contacted about receiving more funding.

### 3. Miscellaneous

1. *Standards and Specifications*: INACSL Standards of Best Practice: Simulation<sup>SM</sup> outlines eleven design criteria, two outcomes and objectives, five facilitation, five debriefing, four participant evaluation, four professional integrity, four simulation interprofessional education, and six operations criteria that will need to be satisfied for the vest to be used in an educational/training setting [5].
  2. *Customer*: The client, Dr. Lohmeier, would like a wearable device with speakers to mimic heart and lung sounds. He would like it to be comfortable, manipulatable, customizable, and be sturdy enough to last over time.
  3. *Patient-Related Concerns*: Since a person will be wearing the vest, we need to make sure the inside of the vest is comfortable enough to be worn without discomfort. The device will need to be sterilized between uses if different people intend to use the vest, especially in the current pandemic, sterilization will be necessary. All materials will need to be safe for human use.
  4. *Competition*: There is currently no competition for this exact product on the market. Components from the present medical simulators will be used as a part of our design. This product is being created to make a more real and educational experience for students when working in medical simulation. The current medical mannequins make it hard for students to get a real feel for what patient to medical worker interaction is actually like. This product will add to the learning experience and hopefully be used and implemented into hospitals and sim labs.
1. *Simulaid's Smart STAT Basic with iPad*: Includes advanced airway management, emergent lung sounds, emergent heart sounds, pulse points, bilateral chest decompressions, bilateral chest tube insertion, and virtual capnography and oximetry. It costs \$13,365 [6].
  2. *Gaumard Gaumard Scientific Co. Inc.*: A full size adult mannequin with movable joints as well as soft fingers and toes for training of important basic nursing skills such as surgical draping, bathing and bandaging, oral and denture hygiene (movable jaw with removable dentures), ophthalmic exercises, ear irrigation and application of otic drops, and I.M. injection (arm and buttock). It costs \$695 [7].

### References:

- [1] US Department of Health and Human Services (1997, February). Good Guidance Practices: Labeling Regulatory Requirements for Medical Devices. *HHS Publication FDA 89-4203*. <https://www.fda.gov/files/medical%20devices/published/Labeling---Regulatory-Requirements-for-Medical-Devices-%28FDA-89-4203%29.pdf>
- [2] National Institute of Justice, "Current and Future Research on Body Armor," January 1, 2010, [nij.ojp.gov:https://nij.ojp.gov/topics/articles/current-and-future-research-body-armor](https://nij.ojp.gov/topics/articles/current-and-future-research-body-armor)
- [3] Bally Ribbon Mills. n.d. Polyethylene | Bally Ribbon Mills <https://www.ballyribbon.com/fibers/polyethylene>
- [4] Total Security Solutions. 2016. Today's Police Body Armor: Overt, Lighter, Smaller. - Total Security Solutions <https://www.tssbulletproof.com/blog/todays-police-body-armor-overt-lighter-smaller>

[5] INACSL Standards Committee (2016, December). INACSL standards of best practice:

Simulation<sup>SM</sup>. *Clinical Simulation in Nursing, 12(S), S5-S47*. <https://www.inacsl.org/INACSL/document-server/?cfp=INACSL/assets/File/public/standards/SOBPEnglishCombo.pdf>.

[6] “Simulaid<sup>SM</sup> SMART STAT Basic with iPad.” *Universal Medical*, [www.universalmedicalinc.com/simulaid-smart-stat-basic-with-ipad.html?campaignid=1049828359](http://www.universalmedicalinc.com/simulaid-smart-stat-basic-with-ipad.html?campaignid=1049828359).

[7] “Simple Simon Patient Care Manikin, Medium Skin.” *1005807 - W45070 - Gaumard Scientific Co. Inc. - S205.M - Adult Patient Care - 3B Scientific*, [www.a3bs.com/simple-simon-patient-care-manikin-medium-skin-1005807-w45070-gaumard-scientific-co-inc-s205m,p\\_153\\_5293.html?utm\\_source=google](http://www.a3bs.com/simple-simon-patient-care-manikin-medium-skin-1005807-w45070-gaumard-scientific-co-inc-s205m,p_153_5293.html?utm_source=google).



**Wearable Simulator for Enhanced Realism**

BME 200/300

October 7A, 2020

**Client:** Dr. Michael Lohmeier

**Advisor:** Dr. Edward Berau

**Team Members:**

Emma Neumann (Team Leader), Gabby Snyder (Communicator),

Rushabh Tolia (BWIG), Elijah McCoy (BSAC),

Tin Tran (Co-BPAC), Caroline Geroldino (Co-BPAC)

[Wearable\\_Simulator\\_Preliminary\\_Report.pdf\(1.2 MB\) - download](#)

**Wearable Simulator for Enhanced Realism**

BME 200/300

*October 7th, 2020***Client:** Dr. Michael Lohmeier**Advisor:** Dr. Edward Bersu**Team Members:**

Emma Neumann (Team Leader), Gabby Snyder (Communicator),

Rushabh Tolia (BWIG), Elijah McCoy (BSAC),

Tim Tran (Co-BPAC), Caroline Gervolino (Co-BPAC)

## Abstract

Simulations are an incredibly useful tool for training medical personnel on high-risk and infrequent scenarios [1]. Although there are many high fidelity simulations on the market, all of them are based around plastic mannequins that lack the ability to interact and move the way a real human could thus breaking a sense of realism for the medical personnel [2]. Therefore, the team proposes a wearable simulation vest that can be worn by an actor or instructor. This will enhance the authenticity of the experience between the medical personnel trainee and the patient by allowing the trainee to interact with someone that can talk, act, and move the way a real patient would. The vest will include speakers that emit heart and lung sounds that are hearable through a stethoscope. The vest will be controlled remotely through an app that will allow either the user or an instructor in a nearby room to control the vest and adjust the sounds to create different scenarios and respond to interventions applied. Ultimately, the goal is to have a functional simulation vest that has heart and lung sounds, and can be used to assist doctors, residents, and nurses in training by providing the most realistic interpretation of any given scenario.

## Table of Contents

<b>Abstract</b>	<b>1</b>
<b>Table of Contents</b>	<b>2</b>
<b>I. Introduction</b>	<b>4</b>
a. Problem Statement	4
b. Impact	4
c. Existing Devices	5
<b>II. Background</b>	<b>8</b>
a. Research	8
b. Client Information	9
c. Design Specification	10
<b>III. Preliminary Designs</b>	<b>11</b>
a. Garment Designs	11
1. The Breast Plate	11
2. Long Sleeves	11
3. The Vest	12
b. Electronics Designs	13
1. Wireless Speakers	13
2. Dial-Controlled Speakers	13
3. AC Generator	14



**IV. Preliminary Design Evaluation 15**

Proposed Final Design 18

**V. Fabrication/Development Process 19**

a. Materials 19

b. Methods 19

c. Final Prototype 20

d. Testing 20

**VI. Results 20****VII. Discussion 20**

a. Sources of Error 20

**VIII. Conclusions 21**

a. Overview 21

b. Future Work 21

**IX. References 22****Appendix 24**

A: Product Design Specifications 24

Function: 24

Client requirements: 24

Design requirements: 25

Physical and Operational Characteristics 25

Production Characteristics 26

Miscellaneous 26

PDS References: 27

## I. Introduction

### a. Problem Statement

Simulations have become a prominent tool in the medical industry to train students and staff in a safe environment on infrequent and risky scenarios [1]. However, mannequins remain inanimate objects that can be hard to interact with in a realistic way. This project aims to create a wearable simulation vest that a human could wear to create a more realistic interpretation of these events. The vest would be equipped with audible heart and lung sounds able to be manipulated and detected for different scenarios similar to mannequin simulators. The vest wearer would then be able to more accurately act out scenarios and interact with the medical students and staff to better portray specific medical conditions, emotions, and body positions.

### b. Impact

The current market for mid-fidelity healthcare simulators is limited due to high prices and limited functionality for purposes of training with an actual patient. For instance, many of the models in the current market are focused on providing training with mannequins that, though designed to be very accurate humanoids, do not provide the needed comprehension when working with a real life being. The idea behind the team's design is to allow actual people to put on the simulation and see how healthcare professionals orient themselves in those scenarios, since working with mannequins rarely allows emotional constructs that are present in real life situations. In addition, the model designed by the team is fairly inexpensive and mobile, compared to many of the available simulators in the market. For example, the SimMan 3G, a high fidelity simulator, costs over \$66,000 for a non-upgraded model, compared to the team's model which has a budget of \$500 [3]. This design is especially important as the simulation market has generated over 2.5 billion dollars in revenue throughout the world [4]. In addition, the model designed by the team will be wearable and simulate many different conditions and ailments a patient may be affected with, thus allowing for a plethora of different scenarios for a healthcare provider to learn from. The individual wearing it can also convey symptoms from a certain condition through acting. For instance, if a patient is suffering from a heart attack, the individual wearing the device can visually display the feelings of pain they would be going through if they were experiencing such a condition.

Practicing on a simulation can improve reaction time and technique for physicians [5]. For example, when an individual suffers from a heart attack they have only 90 minutes from Door-to-Balloon time which is the amount of time after symptoms of a heart attack come up to the time it takes for an angioplasty to take place, a surgical intervention where a balloon is placed into an artery to move aside the cholesterol [6]. As soon as an individual experiences myocardial infarction, the timer starts on how fast they can be saved. The team's simulator will allow for the

optimal timing for the transfer of a patient in an ambulance, with the ambulatory team, to the nurses and physicians waiting at the emergency room entrance, as it will be easily mobile. In addition, since it will be worn by an individual, it will allow for the most optimal setting to learn how to deal with the situation at hand. For instance, the ambulatory team will learn how to properly place a person into a stretcher without causing further discomfort and will learn how to properly analyze the situation and act accordingly in a high pressure situation.

### c. Existing Devices

There are currently a large number of medical mannequins with a variety of fidelities on the market. Some of the most popular mannequins that excel in medical simulation include: “Medical Manekin,” “Simulaid,” and the “SimMan 3G” by Laerdal (Figure 1) [7-9]. The common goal of all the medical mannequins/patient simulators is to mimic life-like and real patient scenarios to train healthcare professionals. They are designed to have medical specialists bring and test their knowledge from inside and outside the classroom, to earn valuable “real-life experiences” so that they are better adapted for the situations they trained for in their specified fields [5]. Healthcare professionals come in contact with the sim-mannequins to comprehend more about certain real life situations and learn from potential errors that can be fixed before interacting with real patients.



**Figure 1:** The SimMan 3G, a high fidelity mannequin intended to accurately represent a human being's symptoms and presentation [9].

The fidelity of these mannequins depend on different models, but most mid- to high-fidelity mannequins are capable of breathing, producing life-like sounds, heart tones, and palpable pulses. They may also connect to an EKG or oscilloscope monitor, pulse oximeter, arterial waveform, pulmonary artery waveform, and anesthetic gases monitor [4]. Many of these mannequins are touch sensitive and provide immediate feedback depending on different interactions from individuals testing with them. Each mannequin has different internal programmable settings depending on the situation they are placed into and are tailored to a specific area of medical expertise for the health professional's comprehension.

The SimMan 3G is the most comprehensive mannequin of the three listed above and is an advanced patient simulator that can display neurological symptoms as well as physiological (Figure 1). It is simple to operate and features innovative technology such as automatic drug recognition, POC ultrasound, advanced ventilation management and patient monitoring. It is controlled via a software called LLEAP, which unifies the operation of all PC operated Laerdal simulators by providing a shared user interface, interchangeable hardware options, and a cohesive simulation experience. It is also remotely controlled, wireless and self-contained, and includes rechargeable batteries which last about four hours. The mannequin's features are extensive in that it has a controllable open/closed airway; automatically or manually controlled, a transtracheal jet ventilation, need/surgical cricothyrotomy, four settings for variable lung and airway compliance and/or resistance, simulated spontaneous breathing, bilateral and unilateral chest rise and fall, oxygen saturation with carbon dioxide exhalation, and lastly normal and abnormal breathing sounds through five anterior auscultation sites and six posterior auscultation sites [9].

## II. Background

### a. Research

The medical mannequin currently used in the UW Hospital Simulation lab is designed by a company called Laerdal. This product includes a silicone skin, air compressors for pulse points, wire hookups to connect to EKG machines, and ultrasound capabilities. The mannequin has the ability to be wireless, but is usually used while plugged in. The mannequin has the ability to produce a pulse at several points, including the neck/throat, hip, wrist, upper arm, and heart. There are pre-programmed noises and phrases that the mannequin can make and say, along with the ability to connect to a microphone where an outside party can relay information. Other major features include crying, bowel sounds (normal, gurgling, constipation), IV setup and injection, Ultrasound probe, EKG hookup, and defibrillator hookup.

Lung and heart sounds are one of first things a medical professional will evaluate during a physical examination. Techniques for listening and diagnosing lung noises include auscultation, which is the process of listening to breathing sounds with a stethoscope; percussion, which involves tapping on the chest to analyze bodily structures; and tactile fremitus, which assesses the vibrations traveling through the chest [10]. Internal breathing sounds are produced in the vocal cords, whereas external signals are results of the chest percussion and airway insonification. Some internal breathing sounds to listen for include, crackles, wheezes, squawks, rhonchus, stridor, and bronchioles [11]. Crackles are short high pitched noises caused by air passing through fluid in the lungs. Wheezes are high pitched whistling noises correlated with asthma or chronic obstructive pulmonary disease. Rhoncus is a low pitched wheeze when breathing out, caused by mucus in the bronchial tubes. Stridor are harsh squeaking noises caused by a blockage in the airway. Lastly, bronchioles are hollow sounding breaths caused by mucus build up in the airways.

Heart sounds can also be extremely useful diagnostically to recognize different problems in the heart. The heart has four distinct sounds that are spaced in a predictable pattern as shown in Figure 2 [12]. Deviation from the norm could signify an abnormality such as a murmur, block, stenosis, or hypertension [12]. Additional heart sounds a doctor could hear and diagnose are bradycardia, the heart beats too slow; tachycardia, heart beats too fast; fibrillation, heart quivers; and premature contraction, an early heartbeat [13].

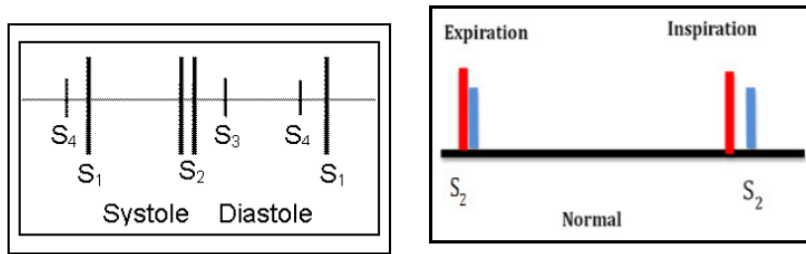

**Figure 2:** Normal Heart Sound. This is a visual representation of the four heart sounds detectable through a stethoscope [12].

To guide the simulation design process, the International Nursing Association for Clinical Simulation and Learning Simulation (INACSL) has implemented standards for medical simulations. These standards include design requirements for foundational evidence, measurable objectives, purpose, theory modality, scenarios, cases, modality, fidelity, prebriefing, debriefing, and pilot test simulation. These design requirements under the INACSL standards ensure that all medical simulators uphold professional integrity, are ethical, and provide valuable learning opportunities [14].

## b. Client Information

The client, Dr. Michael Lohmeier is an emergency medicine doctor for the University of Wisconsin School of Medicine and Public Health. His responsibilities include EMS, prehospital care, mass casualty preparedness, fireground rehab, and resident education. He plays a large role in teaching and assisting students and medical professionals in the University of Wisconsin Simulation Lab. Therefore, he has tasked the team with creating a wearable vest with Sim Man features, including pulse rates and heart sounds while he or another professional can act out situations and communicate with the patients for a more comprehensive learning experience.

## c. Design Specification

The simulation vest design should be a wearable and functional item to be used by the University of Wisconsin-Madison Hospital Simulation Lab and Emergency Department. The vest should be adjustable so that it can be worn by an average sized male. For the most part it will be used by a 6ft 180 lb male, so it should be the length of an average male torso. The vest will have a wearable component as well as an electronic component. Imbedded in the vest there will be a speaker system, which can simulate breathing and heart sounds. The heart sound, pulses, and breathing features should have multiple leads. Pulse sounds should be found on the arms, heart and neck. Breathing should be able to be heard on the front of the vest as well as the back. The vest will be lightweight so that it can be worn for extended periods of time during educational training. For this design, there will be a bluetooth component embedded which will control the speaker and the state of the heart and lungs. The bluetooth component will be connected to an app which can simulate different conditions such as cardiac arrest and murmurs. The sim-vest will be controlled by a second operator at a separate workstation who could manipulate the heart and lung sounds. The vest material will also be made of a cleanable cloth, so that it can be sanitized easily between uses. The vest should be sturdy and withstand years of use when used approximately 8-12 hours a week.

# III. Preliminary Designs

## a. Garment Designs

### 1. The Breast Plate

The breast plate design is the smallest garment design. The breast plate will be a plastic capsule that houses all of the electronics (Figure 3). It will be secured to the actor with adjustable criss cross elastic straps wrapping around the front and back of the actor. This design is the most lightweight and will be easy to sterilize. However, its small size hinders the design's ability to add additional elements in the future and would be restricted to a single touch point.

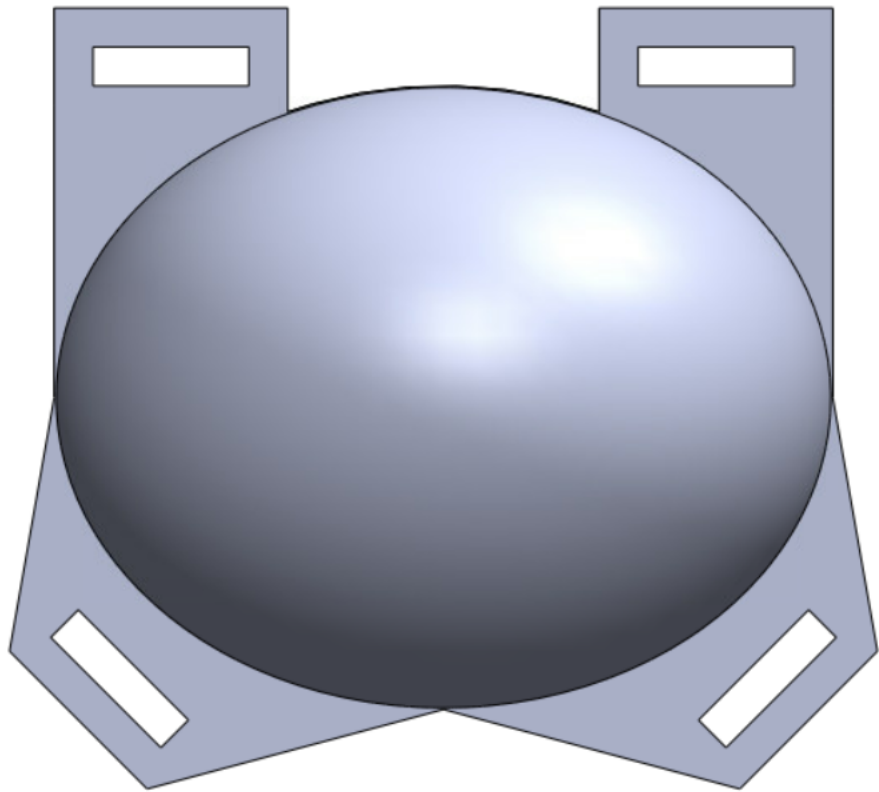
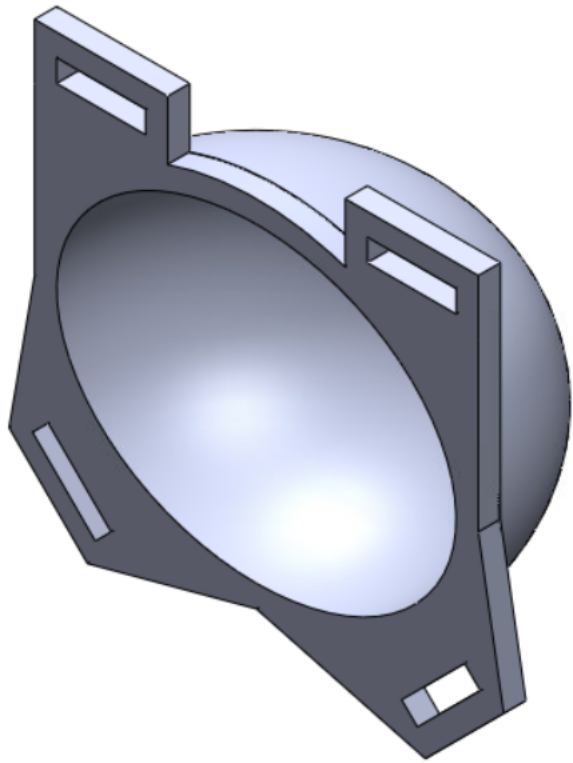

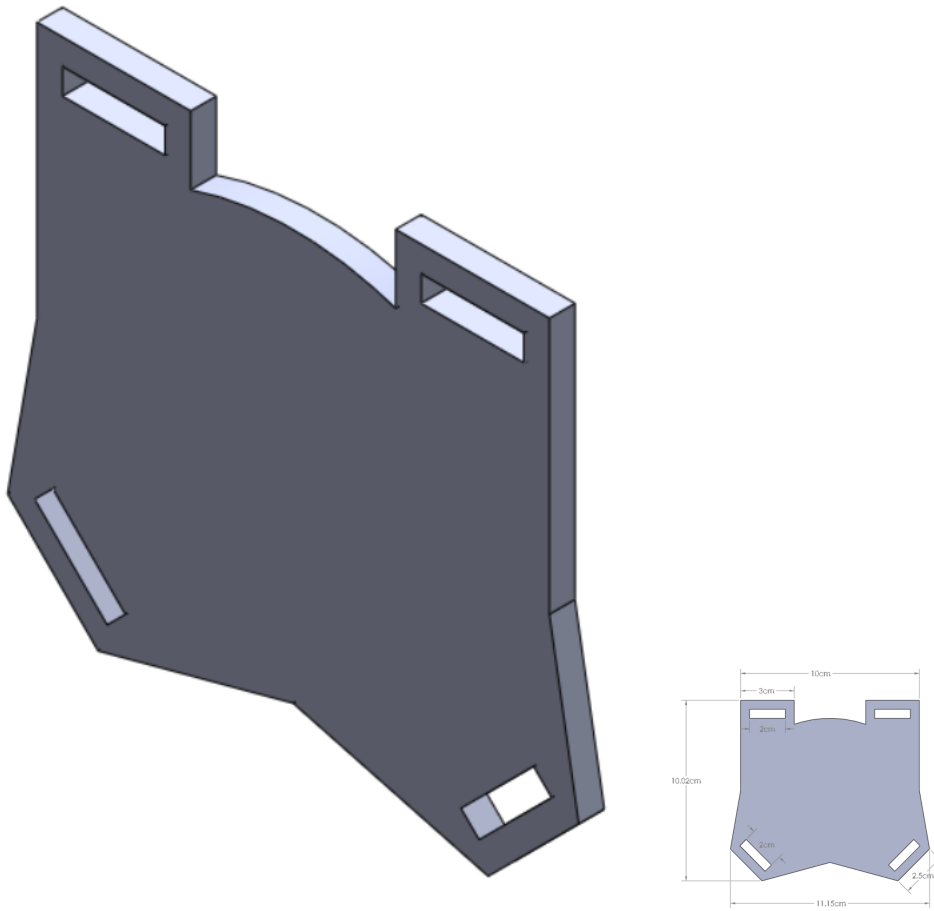

**Figure 3: The Breast Plate.** The first two images depict the front of the capsule. The last two images depict the back of the capsule. The two parts would be joined with fabric straps through the four attachment points in the corners.

## 2. Long Sleeves

The long sleeves design is a full upper body suit. This suit will have a similar form to a vest combined with a turtleneck sweater (Figure 4). The suit will have a zipper in the front which will allow actors to easily put it on. The full upper body design allows for wires to be run to the arms and neck for additional pulse points and speakers. The extra space is also good for the adaptability of the product.



**Figure 4: Long Sleeves.** The long sleeves design would consist of a slim fitting vest and long sleeve, turtleneck. The images depicted are inspiration from which the design would be created from [15,16].

## 3. The Vest

The vest design is the middle ground between the two previous designs. This design has a form similar to life jackets and kevlar vests (Figure 5). The vest will feature a side mesh to allow for better airflow and buckles in the front to allow for adjustability. The vest will be more adaptable than the breastplate and will be easier to sanitize than the long sleeve design.

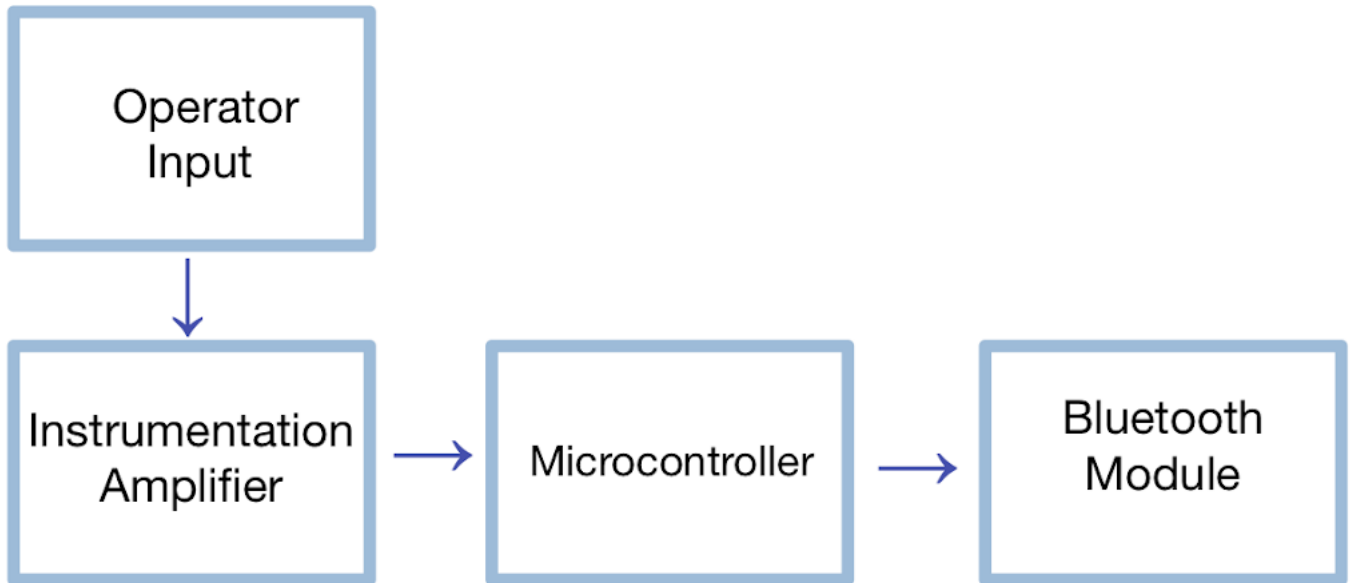

**Figure 5: The Vest.** This design would be made of a waterproof material and be fully adjustable. It would be modeled after a lifejacket similar to the one depicted in this image with pockets, adjustable straps, adjustable waistline, and a zipper [17].

## b. Electronics Designs

### 1. Wireless Speakers

This design will use a programmable app, which will connect via bluetooth, to control the speakers on the vest. This design will eliminate loose wires and allow the vest wearer to move freely. The app increases the functionality of the product, as it could be programmed to run additional scenarios. One drawback of this design will be that it cannot produce electrical waves to simulate heart or lung signals.



**Figure 6:** Wireless speaker block diagram. The wireless speaker system would be run by an external operator. The operator's commands would go through an amplifier, interpreted by a microcontroller, read through a bluetooth module, and emitted through a speaker system.

### 2. Dial-Controlled Speakers

This design will utilize a remote controller connected to the vest that will be accessible by the vest wearer. The remote will be able to flip through pre-programmed scenarios and sounds. Since the vest is controlled by the actor, this cuts out the need for additional people needed for training, which in turn reduces confusion and hassle.

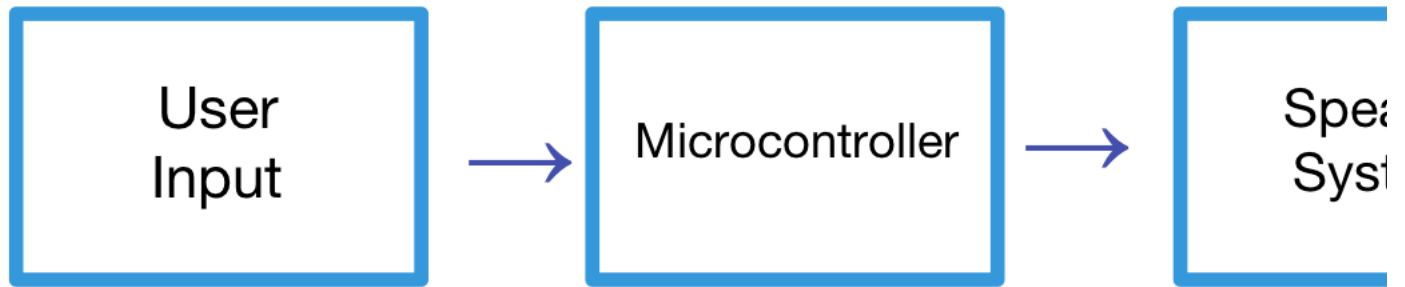

**Figure 7:** Dial-controlled speaker block diagram. This system is a simple three step process where a dial would be directly connected to the microcontroller which would then emit signals to turn the speaker system on and off.

### 3. AC Generator

The AC generator design looks to implement an AC wave generator into the vest in order to produce sounds and electrical signals to mimic the heart and lungs. The drawback of this design is the expense of AC generators and the reduced mobility of the design.

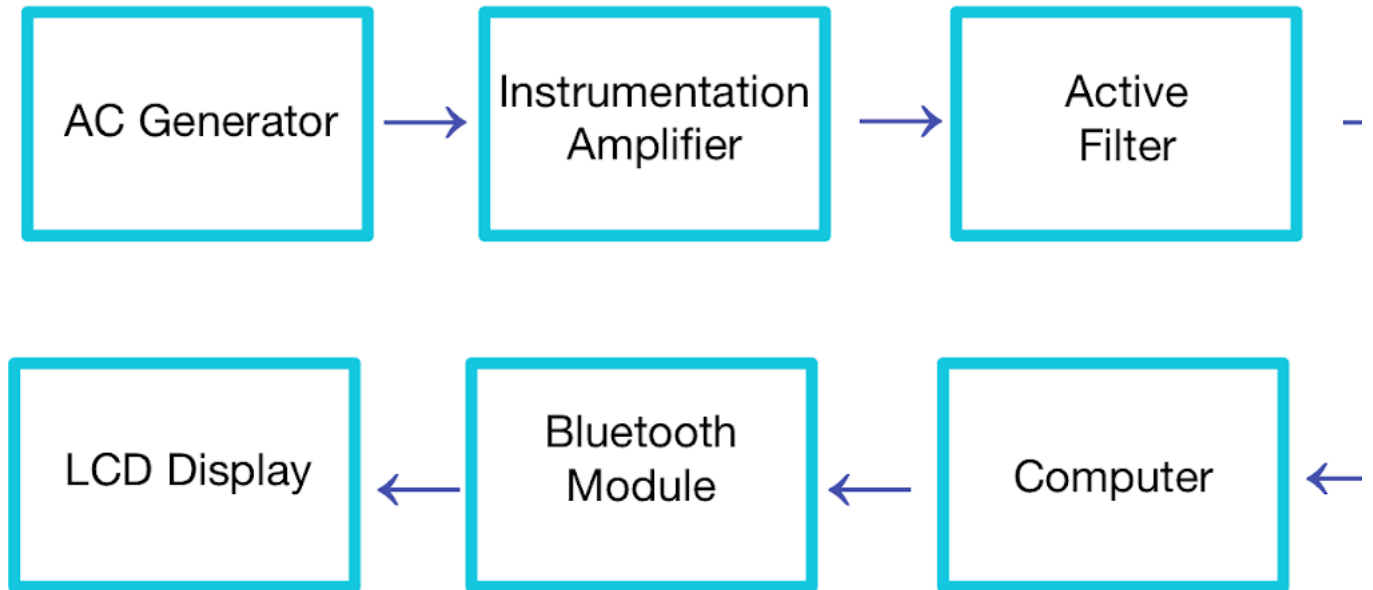

**Figure 8:** AC generator block diagram. This design would require an AC plug-in to the wall. This would be attached to an amplifier which would need to be filtered and shifted to the microcontroller. The microcontroller would be able to interact with the AC wave and would be modulated by the computer and would communicate with the user through a bluetooth and computer connection.

## IV. Preliminary Design Evaluation

### 1. Design Matrices

*Table 1:* The wearable garment design matrix.

Criteria	Weight	Breast Plate	Long Sleeves	The Vest
Adaptability/Fidelity	30	1	5	4
Ease of Manufacturing	20	5	1	3
Comfort	15	4	3	4
Sterilizability	15	4	1	4
Cost	15	5	2	3
Safety	5	5	5	5
<b>Total</b>	<b>100</b>	<b>70</b>	<b>57</b>	<b>74</b>



Table 2: Electronic component design matrix.

Criteria	Weight	Wireless Speakers	Dial-Controlled Speakers	AC Generator
Ease of Manufacturing	25	2	4	1
Safety	20	5	4	2
Accuracy of Output	15	4	4	5
Adaptability	15	4	2	3
Motility	15	5	3	1
Cost	10	4	3	1
<b>Total</b>	<b>100</b>	<b>77</b>	<b>69</b>	<b>42</b>

## 2. Justification of Criteria

*Adaptability/Fidelity:* The adaptability/fidelity of both products is determined by the ability to add more components to it and for it to produce more data. This weighed the highest (30%) for the garment design because a goal for this design would be for it to be used instead of a manikin during simulations. “Long Sleeves” scored the highest, with “The Vest” very close because both of these designs have a larger total area of fabric, meaning there is more area for additional components to be attached. For the electronic design this category weighted 15%, as it is important for the electronic component to be able to produce multiple different types of data (ie sounds, pulses). “Wireless Speakers” scored the highest in this category as the use of an app or bluetooth device would allow multiple data components to be incorporated into the design.

*Ease of Manufacturing:* The ease of manufacturing for both the garment and electronic designs is based on the perceived fabrication ability of the team and the ability to use various resources on campus. The ability of the team to produce effective prototypes is important to determine the effectiveness of the design and ability for the design to be used in live simulations. This received the second highest weight for the garment design (20%) and the highest weight for the electronics design (25%) because if the components cannot be properly fabricated by the team, the overall design will be flawed and unable to be used.

*Comfort:* The comfort of the garment product is determined based on how comfortable the user is while wearing it. This is important because any discomfort will decrease the likelihood of someone wanting to wear the design. Due to the lightweight plastic chest component and the use of thin stretch straps the “Breast Plate” scored the highest in this category.

*Sterilizability:* The sterilizability of the garment design is based on ability for the design to be properly sterilized between each use. This is important, especially given the increase in sanitization protocols due to COVID-19, because this design will be used in clinical settings many different people will be practicing with the device. Both the “Breast Plate” and “The Vest” scored the highest in this category because both designs have an outer layer of some type of plastic coating, making them easy to sanitize.

*Cost:* The cost of both product designs includes the price of the individual components of each design and the total cost of production. A lower cost would be ideal since it would help make the device more marketable to consumers. “Breast Plate” scored the highest and the main component of this design could be 3D printed, which usually has a low fabrication cost. “Wireless Speakers” scored the highest on the electronic side as the creation of an app would be at a zero or very low cost.

*Safety:* If users do not feel safe or are putting themselves in danger while using this product, they will not want to use it, and there could be a high risk of injury. Safety was ranked the lowest in the garment design matrix as all designs were developed to be safe for one to wear. However, safety was ranked second highest (20%) for the electronics components as the likelihood of being electrocuted should be determined for each design. “AC Generator” scored the lowest in this category because, if the wiring is off, there would be a chance the user could be electrocuted while using the device.

*Accuracy of Output:* Accuracy of output of the electronics designs is based on how well the output of the signal corresponds to an individual experiencing similar conditions. This is important because the electronics must generate accurate sounds and pulses during the given scenario or else the entire design would be useless. Since the purpose of the product would be to simulate certain medical situations, if the design cannot accurately produce data for the certain situation, then the person practicing on the design would not benefit or learn how to accurately assess and treat the situation. “AC Generator” scored the highest, by one point, in this category because it would not rely on multiple equations to generate the output data like the “Wireless Speakers” and “Dial Controlled Speakers” would require.

*Motility:* Motility of the electronics designs refers to the ability to remove the circuitry from the garment design, move the circuitry to different positions on the garment, and whether it can be remotely controlled. This is important because the ability to have all of the electronic components fit within the garment design, the easier it would be for the user to wear during simulations. “AC generator” scored the worst in this category because this design would require the user to carry around an AC generator to plug into the wall during use. “Wireless Speakers”

scored the highest in this category as all the electronic circuitry components would be able to be stored within the garment. The wirelessness would allow for a second person to control the output data during use, which is something that the client would like to see in the design.

### 3. Proposed Final Design

The proposed final design will be “The Vest” garment design with the “Wireless Speakers” electronic design. The garment part will have side mesh to allow for breathability and buckles around the midsection to allow for size adjustments. The vest will have an outer layer made of some type of plastic material in order to allow for the design to be easily sterilized in between uses. There will be additional padding used around the shoulder area and other potential areas to provide additional support and comfort for the wearer. Speakers will be placed within both the front and back sides of the vest in order for the design to generate more consistent sounds throughout. These speakers will be used to generate both heart and lung sounds which will correspond to each other and to what one would hear from a living person based on the situation being simulated. These speakers will ideally also be able to be controlled remotely via a bluetooth module, allowing for a second person to make changes to the heart and lungs sounds be generated based on how the person wearing the vest is being treated during the given situation. However, it may be more beneficial for the vest wearer to be able to change the output sounds throughout the scenario as it would eliminate the need for an additional person to be present during the practice of the scenario.

## V. Fabrication/Development Process

### a. Materials

The vest will need to be made of a fabric material that is waterproof, functional, and comfortable. To ensure that the vest is waterproof to protect the electronics and allow for sterilizability, the fabric will need to be coated in a plastic-based film or be chemically treated. The outside of the vest needs to allow for sound to travel through it easily without being overly muffled and needs to be relatively quiet to reduce external noise. The inside of the vest should be made of polyester, cotton, nylon, or a combination of the three to make it comfortable for the wearer while also being durable. The electronics within the vest will comprise of speakers, a microcontroller such as a Raspberry Pi or Arduino, and any additional circuitry required to enable communication between the speakers, microcontroller, and user.

### b. Methods

The team will execute the following tasks to create the final design:

1. Finalize circuit design for internal electronics and order parts.
2. Build circuitry and develop code.
  1. Troubleshoot any challenges that may arise.
  2. Reevaluate design if necessary.
3. Finalize vest design.
4. Either build a complete vest or modify a vest off the market.
5. Integrate the circuitry and vest.
  1. Make any necessary adjustments to seamlessly integrate.
6. Test the prototype for functionality and comfort.
  1. Modify as necessary.
7. If time, or in the future, add pulses, electrical waves, and wireless modalities to design.

### c. Final Prototype

To be completed later in the semester.

### d. Testing

To be completed later in the semester.

## VI. Results

To be completed later in the semester.

## VII. Discussion

### a. Sources of Error

To be completed later in the semester.

## VIII. Conclusions

### a. Overview

Our team has been tasked with creating a wearable, simulation vest for training medical staff. Current simulations have many complex functions and abilities, but lack realism since they are simply mannequins. By creating a vest that an actor or instructor can wear, the simulation becomes much more realistic and beneficial. Upon analyzing different garment and electronic designs, the team has decided on a vest and wireless speaker design. This vest will feature a comfortable, waterproof design with speakers that will play heart and lung sounds. These speakers will be controlled wirelessly via bluetooth.

This section will be expanded upon as the design process and semester progresses.

### b. Future Work

Our future work includes finalizing our design, and moving forward into fabrication. This will involve additional research on circuitry and wireless adaptability to create a circuit that will be safe and effective. For the vest, we need to decide whether we are going to adapt a pre-made vest or create one ourselves.

After fabrication, we will move to integration and testing which will combine the garment and electronic designs and evaluate the functionality, validity, and efficacy of the final prototype. This may lead to alteration in the fabrication process.

Future work design elements could entail more complex breathing and heart mechanisms, motion sensor modeling, and circuitry that could interact with an EKG machine to measure actual electrical signals within the circuitry of the vest.

## IX. References

- [1] S. Barry Issenberg, William C. MCGaghie, Emil R. Petrusa, David Lee Gordon & Ross J. Scalese  
(2005) Features and uses of high-fidelity medical simulations that lead to effective learning: a BEME systematic review, *Medical Teacher*, 27:1, 10-28, DOI: 10.1080/01421590500046924
- [2] Zoë Paskins & Ed Peile (2010) Final year medical students' views on simulation-based teaching:  
A comparison with the Best Evidence Medical Education Systematic Review, *Medical Teacher*, 32:7, 569-577, DOI: 10.3109/01421590903544710
- [3] Laerdal Medical Corp. July 29 2014. Pricelist Update PC62203. [https://www.ogs.state.ny.us/purchase/spg/pdfdocs/3823219745PL\\_Laerdal.pdf](https://www.ogs.state.ny.us/purchase/spg/pdfdocs/3823219745PL_Laerdal.pdf)
- [4] High Fidelity Simulation: Healthcare Simulation. (2019, March 21). Retrieved September 24, 2020, from <http://www.healthysimulation.com/high-fidelity-simulation/>
- [5] Yasuharu Okuda, et al. (2009) The Utility of Simulation in Medical Education: What is the Evidence? *Mount Sinai Journal Of Medicine*, V76:14, <https://doi.org/10.1002/msj.20127>
- [6] What is Door-to-Balloon Time? – Penn Medicine. (n.d.). Retrieved from <https://www.pennmedicine.org/updates/blogs/heart-and-vascular-blog/2017/january/door-to-balloon>
- [7] "Medical Manikin: Healthcare Simulation." *HealthySimulation.com*, 1 Oct. 2019, [www.healthysimulation.com/medical-manikin/](http://www.healthysimulation.com/medical-manikin/).
- [8] "Simulaid's SMART STAT Basic with iPad." *Universal Medical*, [www.universalmedicalinc.com/simulaid-s-smart-stat-basic-with-ipad.html?campaignid=1049828359](http://www.universalmedicalinc.com/simulaid-s-smart-stat-basic-with-ipad.html?campaignid=1049828359).
- [9] SimMan® 3G. (n.d.). Retrieved October 06, 2020, from <https://www.laerdal.com/us/doc/85/SimMan-3G>
- [10] A. Rao, E. Huynh, T. J. Royston, A. Kornblith, and S. Roy, "Acoustic Methods for Pulmonary Diagnosis," *NCBI*, 2019. [Online]. Available: <https://www.ncbi.nlm.nih.gov/pmc/articles/PMC6874908/>. [Accessed: 23-Sep-2020].
- [11] Kahn, A. (2019, September 18). Breath Sounds: Types, Causes, and Treatments. Retrieved from <https://www.healthline.com/health/breath-sounds>
- [12] "Pediatric Cardiology." (2020) Cardiac Cycle, [www.utmb.edu/Pedi\\_Ed/CoreV2/cardiology/Cardiology3.html](http://www.utmb.edu/Pedi_Ed/CoreV2/cardiology/Cardiology3.html).

- [13] "Abnormal Heart Rhythms & Arrhythmia | MemorialCare", *Memorialcare.org*, 2020. [Online].  
<https://www.memorialcare.org/services/heart-vascular-care/abnormal-heart-rhythms-arrhythmias>. [Accessed: 17- Sep- 2020].
- [14] INACSL Standards Committee (2016, December). INACSL standards of best practice: SimulationSM. *Clinical Simulation in Nursing*, 12(S), S5-S47.  
<https://www.inacsl.org/INACSL/document-server/?cfp=INACSL/assets/File/public/standards/SOBPEnglishCombo.pdf>.
- [15] "2021 Ronix Supreme Athletic Cut Comp Vest." *WakeMAKERS Wakeboard Ballast and Wakesurf Store*, [www.wakemakers.com/ronix-supreme-athletic-cut-comp-vest.html](http://www.wakemakers.com/ronix-supreme-athletic-cut-comp-vest.html).
- [16] Sharon, et al. "KOGMO - KOGMO Womens Long Sleeve Solid Basic Fitted Turtleneck Shirt." *Walmart.com*, 11 Sept. 2020, [www.walmart.com/ip/KOGMO-Womens-Long-Sleeve-Solid-Basic-Fitted-Turtleneck-Shirt/715973613](http://www.walmart.com/ip/KOGMO-Womens-Long-Sleeve-Solid-Basic-Fitted-Turtleneck-Shirt/715973613).
- [17] "NRS Chinook OS Fishing Lifejacket (PFD)." *OutdoorPlay*, [www.outdoorplay.com/nrs-fishing-lifejacket-pfd](http://www.outdoorplay.com/nrs-fishing-lifejacket-pfd).

## Appendix

### A: Product Design Specifications

*Wearable Simulator for Enhanced Realism*

Updated: 10/7/2020

Client: Dr. Michael Lohmeier [mtlohmei@medicine.wisc.edu](mailto:mtlohmei@medicine.wisc.edu)

Advisor: Dr. Ed Bersu [etbersu@wisc.edu](mailto:etbersu@wisc.edu)

Team: Emma Neumann [ekneumann@wisc.edu](mailto:ekneumann@wisc.edu) (Leader)

Gabby Snyder [gesnyder@wisc.edu](mailto:gesnyder@wisc.edu) (Communicator)

Rushabh Tolia [rtolia@wisc.edu](mailto:rtolia@wisc.edu) (BWIG)

Elijah McCoy [epmccoy@wisc.edu](mailto:epmccoy@wisc.edu) (BSAC)

Caroline Gervolino [gervolino@wisc.edu](mailto:gervolino@wisc.edu) (Co-BPAG)

Tim Tran [ttran28@wisc.edu](mailto:ttran28@wisc.edu) (Co-BPAG)

#### Function:

Simulations have become a prominent tool in the medical industry to train students and staff in a safe environment on infrequent and risky scenarios. However, mannequins remain inanimate objects that can be hard to interact with in a realistic way. This project aims to create a wearable simulation vest that a human could wear to create a more realistic interpretation of these events. The vest would be equipped with audible and electrical body function simulators able to be manipulated and detected for different scenarios similar to mannequin simulators. The vest wearer would then be able to more accurately act out scenarios and interact with the medical students and staff to better portray specific medical conditions, emotions, and body positions.

#### Client requirements:

- No more than \$500
- Must be a wearable simulator of reasonable weight and size to fit the average person
- Can be used 4-5 times a month
- Outputs can be modified during simulation to respond to interventions
- Simulates heart sounds and pulses
- Simulates lung sounds

#### Design requirements:

##### 1. Physical and Operational Characteristics

1. *Performance Requirements*: This design should be something that can be worn comfortably on the upper body of a person and can produce varied heart sounds and pulses. It should be able to be used about four to five times a month and able withstand the force exerted by the user each time. The device should also be adjustable to fit the various builds of the user.

2. *Safety*: This product will contain electrical equipment that will be properly enclosed, grounded, and equipped with a kill switch. The edges of the vest will be soft and rounded to prevent injury, and it will be designed to keep as full of a range of motion as possible. Anyone wearing the vest, will need to be trained on how to properly use it. Proper labeling on the vest will warn users of the electrical components present and the thermal risk of wearing the vest for extended periods of time to avoid overheating. There will also be a disclaimer reminding users that the vest is a simulation of medical conditions, but does not perfectly mimic all conditions or all aspects of those conditions. All labeling will adhere to FDA Labeling Regulatory Requirements for Medical Devices [1].
3. *Accuracy and Reliability*: This product will have two components, the wearable vest component and the electronic components. The vest will be built with strong materials so that it is reliable, accurate, and will not rip or break when worn by an actor of the correct size. The electronic portion will be based on current simulator technology. With high quality technology installed in the vest, it should be able to produce reliable results almost every time.
4. *Life in Service*: This product will be made of sturdy materials similar to those in a kevlar vest, which uses sail cloth and polyethylene fibers [2]. With these strong materials and the vest being used about 8-12 hours a week, the vest should be able to be worn for multiple years in a medical education setting before needing to be replaced or repaired. The vest simulator will also have an electronic component for measurements including heart sounds, pulse, and a speaker system. These features will be similar to the technology used in the current simulators and mannequins, which have been used in medical practice for many years, and have proven to be durable and provide accurate information.
5. *Shelf Life*: The vest itself will mostly be made from polyethylene fibers, which has an indefinite longevity [3]. The batteries for the electronics, that will be needed to moderate the heart and breathing sounds, will need to be changed/charged once every few months depending on usage, which is the only potential corrosive aspect of the device.
6. *Operating Environment*: The device will mostly be used by EMTs and medical students as a training model for real-life patients. The training with the device will mostly occur in special simulator training areas. The device will need outlets and a table for the electronic kits included with the vest and will require an environment that has no contact with any aqueous solutions.
7. *Ergonomics*: The vest itself will be easily portable with the various electronic kits that will be sized into a well balanced tool kit. The vest itself will be reasonably weighted and sized to avoid weighing down the user and to maintain as much range of motion as possible.
8. *Size*: The design for this product should be created to be comfortably worn by a 6ft, 185lb male. It should not be overly heavy and bulky or restrict movement of the waist, shoulders, and neck.
9. *Weight*: This product will be worn by actors for potentially long periods of time; therefore, to maximize comfort and functionality, the vest, including the electrical components, will be a maximum of 5-6 pounds, similar to the weight of a kevlar vest [4].
10. *Materials*: For a balance between strength, weight, comfort, and affordability, the vest will be made out of canvas and strong fibers such as polyethylene and sail cloth [3].
11. *Aesthetics, Appearance, and Finish*: It is important that there are no sharp edges on the design and that the material chosen does not cause excess irritation or pain to the skin. There should be no loose wires or anything sticking out. The device should be pleasing to look at and all parts should be attached cleanly.

## 2. Production Characteristics

1. *Quantity*: A single prototype vest will be created. Ideally more vests would be created and at a lower cost in the future.
2. *Target Product Cost*: There is an initial budget of no more than \$500, but if more money is needed Dr. Lohmeier can be contacted about receiving more funding.

## 3. Miscellaneous

1. *Standards and Specifications*: INACSL Standards of Best Practice: Simulations<sup>SM</sup> outlines eleven design criteria, two outcomes and objectives, five facilitation, five debriefing, four participant evaluation, four professional integrity, four simulation interprofessional education, and six operations criteria that will need to be satisfied for the vest to be used in an educational/training setting [5].
2. *Customer*: The client, Dr. Lohmeier, would like a wearable device with speakers to mimic heart and lung sounds. He would like it to be comfortable, manipulatable, customizable, and be sturdy enough

to last over time.

3. *Patient-Related Concerns*: Since a person will be wearing the vest, we need to make sure the inside of the vest is comfortable enough to be worn without discomfort. The device will need to be sterilized between uses if different people intend to use the vest, especially in the current pandemic, sterilization will be necessary. All materials will need to be safe for human use.
  4. *Competition*: There is currently no competition for this exact product on the market. Components from the present medical simulators will be used as a part of our design. This product is being created to make a more real and educational experience for students when working in medical simulation. The current medical mannequins make it hard for students to get a real feel for what patient to medical worker interaction is actually like. This product will add to the learning experience and hopefully be used and implemented into hospitals and sim labs.
1. *Simulaids Smart STAT Basic with iPad*: Includes advanced airway management, emergent lung sounds, emergent heart sounds, pulse points, bilateral chest decompressions, bilateral chest tube insertion, and virtual capnography and oximetry. It costs \$13,365 [6].
  2. *Gaumard Gaumard Scientific Co. Inc.*: A full size adult mannequin with movable joints as well as soft fingers and toes for training of important basic nursing skills such as surgical draping, bathing and bandaging, oral and denture hygiene (movable jaw with removable dentures), ophthalmic exercises, ear irrigation and application of otic drops, and I.M. injection (arm and buttock). It costs \$695 [7].

#### PDS References:

- [1] US Department of Health and Human Services (1997, February). Good Guidance Practices: Labeling Regulatory Requirements for Medical Devices. *HHS Publication FDA 89-4203*. <https://www.fda.gov/files/medical%20devices/published/Labeling---Regulatory-Requirements-for-Medical-Devices-%28FDA-89-4203%29.pdf>
- [2] National Institute of Justice, "Current and Future Research on Body Armor," January 1, 2010, [nij.ojp.gov:https://nij.ojp.gov/topics/articles/current-and-future-research-body-armor](https://nij.ojp.gov/topics/articles/current-and-future-research-body-armor)
- [3] Bally Ribbon Mills. n.d. Polyethylene | Bally Ribbon Mills <https://www.ballyribbon.com/fibers/polyethylene>
- [4] Total Security Solutions. 2016. Today's Police Body Armor: Overt, Lighter, Smaller. - Total Security Solutions <https://www.tssbulletproof.com/blog/todays-police-body-armor-overt-lighter-smaller>
- [5] INACSL Standards Committee (2016, December). INACSL standards of best practice: Simulations<sup>SM</sup>. *Clinical Simulation in Nursing, 12(S), S5-S47*. <https://www.inacsl.org/INACSL/document-server/?cfp=INACSL/assets/File/public/standards/SOBPEnglishCombo.pdf>.
- [6] "Simulaids SMART STAT Basic with iPad." *Universal Medical*, [www.universalmedicalinc.com/simulaids-smart-stat-basic-with-ipad.html?campaignid=1049828359](http://www.universalmedicalinc.com/simulaids-smart-stat-basic-with-ipad.html?campaignid=1049828359).
- [7] "Simple Simon Patient Care Manikin, Medium Skin." 1005807 - W45070 - *Gaumard Scientific Co. Inc.* - S205.M - *Adult Patient Care - 3B Scientific*, [www.a3bs.com/simple-simon-patient-care-manikin-medium-skin-1005807-w45070-gaumard-scientific-co-inc-s205m\\_p\\_153\\_5293.html?utm\\_source=google](http://www.a3bs.com/simple-simon-patient-care-manikin-medium-skin-1005807-w45070-gaumard-scientific-co-inc-s205m_p_153_5293.html?utm_source=google).



# Final Poster and Presentation

EMMA NEUMANN - Dec 09, 2020, 10:26 AM CST



Wearable\_Sim\_Poster.pdf(810.7 KB) - [download](#)

GABRIELLE SNYDER - Dec 09, 2020, 6:02 PM CST



Wearable\_Sim\_Final\_Presentation.mp4(34.9 MB) - [download](#)



**Wearable Simulator for Enhanced Realism**

BME 200/300

*December 9th, 2020*

**Client:** Dr. Michael Lohmeier

**Advisor:** Dr. Edward Berna

**Team Members:**

Emma Neumann (Team Leader), Gabby Snyder (Communicator),

Rishabh Tolia (BWIG), Elijah McCoy (BSAC),

Tim Tran (Co-BPAC), Caroline Gervolino (Co-BPAC)

**Final\_Report.pdf(1.4 MB) - [download](#)**



# The Cardiac Cycle and Heart Sounds

EMMA NEUMANN - Sep 23, 2020, 8:04 AM CDT

**Title:** The Cardiac Cycle Heart Sounds

**Date:** 9/23/2020

**Content by:** Emma Neumann

**Present:** Emma Neumann

**Goals:** Learn more about the heart and what would need to be simulated in our design.

**Content:**

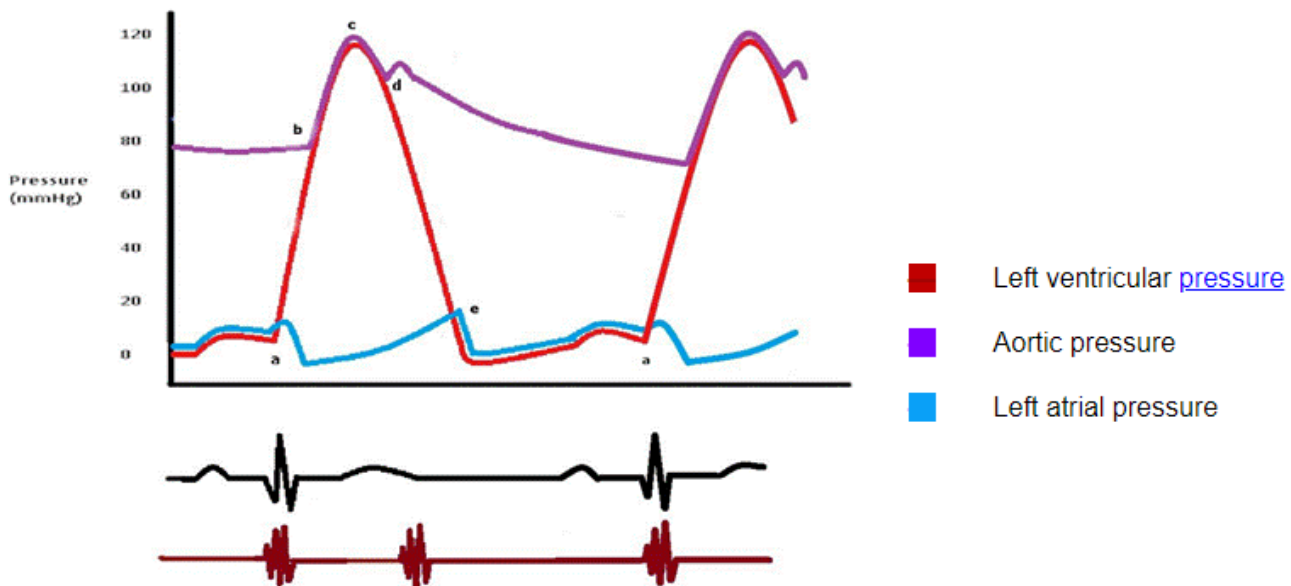

- phases

- a-b: isovolumetric ventricular contraction
  - beginning of systole
  - AV valve closes at a
  - ventricle gains positive pressure w/o changing volume to overcome semilunar valve resistance at b
  - lasts 6% of cycle
- b-c: rapid ejection
  - semilunar valves open at b
  - rapid ejection of blood
  - arterial pressure increases until maximum at c
  - lasts 13% of cycle
- c-d: reduced ejection
  - start of ventricular repolarization
  - start of T wave
  - ventricular pressure decreases
  - some blood flow continues due to remaining KE
  - lasts 15% of cycle
- d-e: isovolumetric relaxation
  - ventricular pressure below diastolic aortic and pulmonary pressures
  - aortic and pulmonary valves close which produces the heart sound at d
  - beginning of diastole
  - ventricular pressure is less than atrial
  - lasts 8% of cycle
- e-a: ventricular filling
  - av valves open at e

- ventricular starts filling
- pressure increases in ventricle until equal to atrial and then av valve closes at a
- lasts 44% of cycle
- atrial contraction
  - end of ventricular diastole
  - atrial contraction adds 10% of ventricular filling volume
  - p wave
  - lasts 14% of the cycle

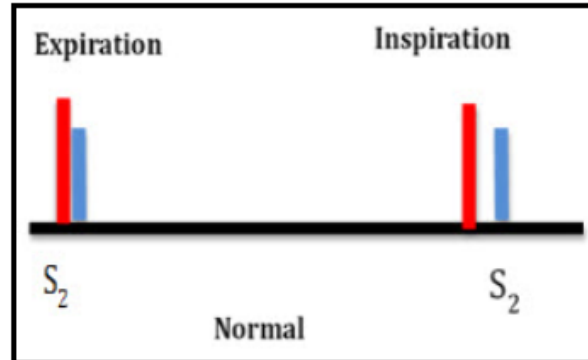
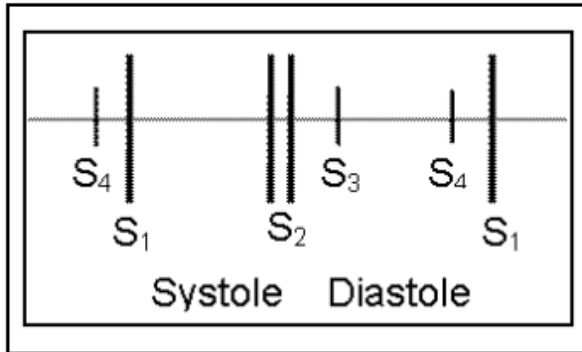

- heart sounds
  - S<sub>1</sub>: first heart sound
    - closure of mitral and tricuspid valves
    - single sound because they happen simultaneously
    - corresponds to the pulse
  - S<sub>2</sub>: second heart sound
    - closure of aortic and pulmonary valves
    - usually split because A<sub>2</sub> is slightly before P<sub>2</sub>
    - more noticeable with slower heart rates
    - can have abnormally wide splitting
      - RV overload w/ atrial septal defect
      - RV outflow obstruction w/ pulmonary stenosis
      - delayed RV depolarization w/ complete right bundle branch block
    - can have narrow splitting
      - pulmonary hypertension as pulmonary valves closes early
      - mild to moderate aortic stenosis as the A<sub>2</sub> is delayed
    - can have single S<sub>2</sub>
      - one of the semilunar valves is missing w/ pulmonary/aortic valve atresia and truncus arteriosus
      - both valves close simultaneously w pulmonary hypertension or large VSD
      - posterior displacement of pulmonary valve away from chest wall w/ d-TGA
    - can have paradoxical splitting (P<sub>2</sub> before A<sub>2</sub>)
      - severe aortic stenosis
      - left bundle branch block
  - S<sub>3</sub>: third heart sound
    - transition from fast to slow ventricular filling in early diastole
    - heart in normal children
  - S<sub>4</sub>: fourth heart sound
    - abnormal late diastolic sound from forcible atrial contraction when decreased ventricular compliance
- heart murmurs
  - additional sounds from turbulent blood flow
  - can be systolic, diastolic, or continuous
  - grading
    - I/VI: barely audible
    - II/VI: faint but easily audible
    - III/VI: loud murmur w/o palpable thrill
    - IV/VI: load murmur w/ palpable thrill
    - V/VI: very loud murmur heart w/ stethoscope lightly on chest
    - VI/VI: very loud murmur heart w/o stethoscope

<b>Table showing the common systolic, diastolic and continuous heart murmurs</b>	
<b>Systolic</b>	<ul style="list-style-type: none"> <li>SEM: Innocent murmurs, obstructive lesions*, ASD</li> <li>Holosystolic: VSD, MR, TR (mitral and tricuspid insufficiency)</li> <li>Decrescendo: usually with small VSDs (as VSD almost closes by the end of systole)</li> </ul>
<b>Diastolic</b>	<ul style="list-style-type: none"> <li>Early: AI, PI (aortic and pulmonary insufficiency)</li> <li>Mid: relative mitral stenosis (VSD) or relative tricuspid stenosis (ASD)</li> <li>Late: Rheumatic MS (mitral stenosis)</li> </ul>
<b>Continuous</b>	<ul style="list-style-type: none"> <li>Usually vascular in origin when a high-pressure vessel communicates with a low-pressure vessel e.g. PDA (beyond the neonatal period), BT shunt, AV malformation anywhere in the body (heart, lungs, brain, liver or pregnant uterus)</li> </ul>
*Obstructive lesions include AS, PS, Coarctation of the aorta, TOF, etc.	

<b>Table showing the common heart murmurs audible at different age</b>	
Immediately after birth	PDA or obstructive lesions*
Shortly after birth (a few hours to few weeks)	VSD, PDA, PPS (peripheral pulmonary stenosis)
1-4 years	Innocent murmurs, ASD
Teenage	Innocent murmur, HOCM or MVP/MR
*Obstructive lesions include AS, PS, Coarctation of the aorta, TOF, etc	

[https://www.utmb.edu/Pedi\\_Ed/CoreV2/cardiology/Cardiology3.html](https://www.utmb.edu/Pedi_Ed/CoreV2/cardiology/Cardiology3.html)

#### **Conclusions/action items:**

find recordings of all these sounds to add to the simulation and label them with their appropriate type



## Heart Sounds Video

---

EMMA NEUMANN - Sep 23, 2020, 8:14 AM CDT

**Title:** Heart Sounds Video

**Date:** 9/23/2020

**Content by:** Emma Neumann

**Present:** Emma Neumann

**Goals:** Hear what different heart sound actually sound like

**Content:**

- healthy heart
  - lub dub sound
- mitral regurgitation, tricuspid regurgitation
  - maintain sound through systole
- aortic stenosis, pulmonic stenosis
  - crescendo/decrescendo during systole
  - has a quick click right before
- aortic regurgitation, pulmonic regurgitation, mitral stenosis, tricuspid stenosis
  - decreases through diastole
- also shows you where to best hear all of the sounds

<https://www.youtube.com/watch?v=dBwr2GZCmQM>

**Conclusions/action items:**

create a map of the sounds and where each can be best heard to most accurately place the sounds on the vest



EMMA NEUMANN - Sep 23, 2020, 7:38 AM CDT

**Title:** SimMan 3G**Date:** 9/23/2020**Content by:** Emma Neumann**Present:** Emma Neumann**Goals:** Find out what is on the market and what features it has.**Content:**

- fully automated mannequin
- can be used for:
  - POC ultrasound
  - advanced ventilation management
  - patient monitoring
- controlled with LLEAP
  - can be remotely controlled
  - wireless and self-contained
  - rechargeable batteries
  - lasts about 4 hrs
  - can control multiple manikins with one interface
- features
  - multiple airway features and complications
  - breathing features and complications
  - cardiac features
  - circulation features
  - vascular access
  - cpr
  - eyes
  - seizure
  - bleeding
  - bowel sounds
  - patient voice
  - instructor communication
  - pharmacology
- certifications: UL, CE, FCC, CSA, HMR

<https://www.laerdal.com/us/products/simulation-training/emergency-care-trauma/simman-3g/>

**Conclusions/action items:**

Find out what those certifications all mean and if we need to follow them.

Determine which of these features we want to include.



## FDA Labeling Requirements

---

EMMA NEUMANN - Sep 16, 2020, 5:28 PM CDT

**Title:** FDA Labeling Regulatory Requirements for Medical Devices

**Date:** 9/16/2020

**Content by:** Emma Neumann

**Present:** Emma Neumann

**Goals:** Find out what types of labeling will be required on our simulation.

**Content:**

- the labeling cannot be false or misleading
- we need to include a disclaimer that it is a simulation and may not be a fully accurate or a replacement for real world exposure
- need to include a label about the electronics involved
  - have a label about electrocution if in water
- need to include directions
- need to include a label warning people about overheating since it is a heavy device worn
- there are exemptions if the device is strictly for educational purposes (which ours would be)

US Department of Health and Human Services (1997, February). Good Guidance Practices: Labeling Regulatory Requirements for Medical Devices. *HHS Publication FDA 89-4203*. <https://www.fda.gov/files/medical%20devices/published/Labeling---Regulatory-Requirements-for-Medical-Devices-%28FDA-89-4203%29.pdf>

**Conclusions/action items:**

This may not have been the best document, but it was closest thing I could find to our device, but it does not specifically mention simulations since it is a bit outdated. The main ones we need though are the electronics, thermal, and simulation warnings.



**Title: INACSL Standards of Best Practice: Simulation**

**Date:** 9/16/2020

**Content by:** Emma Neumann

**Present:** Emma Neumann

**Goals:** Find out if there are any standards for medical educational simulations

**Content:**

1. Simulation Design

1. Perform a needs assessment to provide the foundational evidence of the need for a well-designed simulation-based experience.
2. Construct measureable objectives.
3. Structure the format of a simulation based on the purpose, theory, and modality for the simulation-based experience.
4. Design a scenario or case to provide the context for the simulation-based experience.
5. Use various types of fidelity to create the required perception of realism.
6. Maintain a facilitative approach that is participant-centered and driven by the objectives, participant's knowledge or level of experience, and the expected outcomes.
7. Begin simulation-based experiences with a prebriefing.
8. Follow simulation-based experiences with a debriefing and/or feedback session.
9. Include an evaluation of the participant(s), facilitator(s), the simulation-based experience, the facility, and the support team.
10. Provide preparation materials and resources to promote participants' ability to meet identified objectives and achieve expected outcomes of the simulation-based experience.
11. Pilot test simulation-based experiences before full implementation

2. Outcomes and Objectives

1. Determine expected outcomes for simulationbased activities and/or programs.
2. Construct Specific, Measurable, Achievable, Realistic, Time-phased objectives based on expected outcomes.

3. Facilitation

1. Effective facilitation requires a facilitator who has specific skills and knowledge in simulation pedagogy
2. The facilitative approach is appropriate to the level of learning, experience, and competency of the participants.
3. Facilitation methods prior to the simulationbased experience include preparatory activities and a prebriefing to prepare participants for the simulation-based experience.
4. Facilitation methods during a simulationbased experience involve the delivery of cues (predetermined and/or unplanned) aimed to assist participants in achieving expected outcomes.
5. Facilitation after and beyond the simulation experience aims to support participants in achieving expected outcomes.

4. Debriefing

1. The debrief is facilitated by a person(s) competent in the process of debriefing.
2. The debrief is conducted in an environment that is conducive to learning and supports confidentiality, trust, open communication, self-analysis, feedback, and reflection.
3. The debrief is facilitated by a person(s) who can devote enough concentrated attention during the simulation to effectively debrief the simulation-based experience.
4. The debrief is based on a theoretical framework for debriefing that is structured in a purposeful way.
5. The debrief is congruent with the objectives and outcomes of the simulation-based experience.

5. Participant Evaluation

1. Determine the method of participant evaluation prior to the simulation-based experience.
2. Simulation-based experiences may be selected for formative evaluation.
3. Simulation-based experiences may be selected for summative evaluation.
4. Simulation-based experiences may be selected for high-stakes evaluation.

6. Professional Integrity

1. Foster and role model attributes of professional integrity at all times.
2. Follow standards of practice, guidelines, principles, and ethics of one's profession.

3. Create and maintain a safe learning environment (See INACSL Standard: Facilitation).
  4. Require confidentiality of the performances and scenario content based on institutional policy and procedures.
7. Simulation-Enhanced interprofessional Education (Sim-IPE)
1. Conduct Sim-IPE based on a theoretical or a conceptual framework.
  2. Utilize best practices in the design and development of Sim-IPE.
  3. Recognize and address potential barriers to Sim-IPE.
  4. Include an appropriate evaluation plan.
8. Operations
1. Implement a strategic plan that coordinates and aligns resources of the SBE program to achieve its goals.
  2. Provide personnel with appropriate expertise to support and sustain the SBE program.
  3. Use a system to manage space, equipment, and personnel resources.
  4. Maintain and manage the financial resources to support stability, sustainability, and growth of the SBE program's goals and outcomes.
  5. Use a formal process for effective systems integration.
  6. Create policies and procedures to support and sustain the SBE program

INACSL Standards Committee (2016, December). INACSL standards of best practice: Simulations<sup>SM</sup>. *Clinical Simulation in Nursing*, 12(S), S5-S47. <https://www.inacsl.org/INACSL/document-server/?cfp=INACSL/assets/File/public/standards/SOBPEnglishCombo.pdf>.

**Conclusions/action items:**

There are eleven design criteria, two outcomes and objectives, five facilitation, five debriefing, four participant evaluation, four professional integrity, four simulation interprofessional education, and six operations criteria we need to consider in our design. Not all of them are relevant to our project, but we should definitely go through all of them when we create our design.





## 10/6/2020 Breast Plate Solidworks

EMMA NEUMANN - Oct 06, 2020, 10:59 PM CDT

**Title:** Breast Plate Solidworks

**Date:** 10/6/2020

**Content by:** Emma Neumann

**Present:** Emma Neumann, Gabby Snyder

**Goals:** Create a 3D mockup of the breast plate capsule

**Content:**

\*solidworks files are below

**Conclusions/action items:**

Add into report

EMMA NEUMANN - Oct 06, 2020, 10:59 PM CDT



breastplatefront.SLDPRT(180.5 KB) - [download](#)

EMMA NEUMANN - Oct 06, 2020, 10:59 PM CDT



breastplateback.SLDPRT(109.2 KB) - [download](#)



## 9/23/2020 Initial Design Ideas

EMMA NEUMANN - Sep 23, 2020, 8:37 AM CDT

### Title: Removable Electronics Idea

Date: 9/23/2020

Content by: Emma Neumann

Present: Emma Neumann

Goals: come up with 3 designs to bring to the group for ideas for the preliminary designs

### Content:

\*picture below

### Conclusions/action items:

discuss pros and cons of these designs and other designs with team members

come up with more detailed electronic design ideas

EMMA NEUMANN - Sep 23, 2020, 8:35 AM CDT

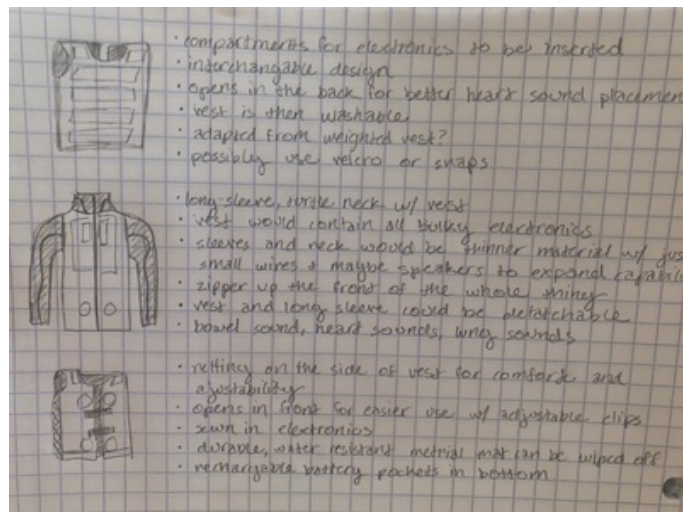

Initial\_Designs.jpg(323.4 KB) - [download](#)



## 10/6/2020 Heart and Lung Sounds Library

---

EMMA NEUMANN - Oct 06, 2020, 11:07 PM CDT

Title: Heart and Lung Sounds Library

Date: 10/6/2020

Content By: Emma Neumann

Present: Emma Neumann

Goal: Find a bank of open-sourced heart and lung sounds we could potentially pull from for our speakers to use.

Content:

Thinklabs One Digital Stethoscope has a huge library of sounds. They have it available on their youtube channel and through an app. We may be able to pull from their app to integrate into our design.

[youtube.com/c/Thinklabs1/videos](https://www.youtube.com/c/Thinklabs1/videos)

<https://www.thinklabs.com/heart-sounds>

Conclusion/Action Items:

Find out if we could actually use these sounds.

Find out how muffled these sounds are behind fabric.



## Adafruit Audio FX Sound Board

---

EMMA NEUMANN - Oct 26, 2020, 8:14 AM CDT

**Title:** Adafruit Audio FX Sound Board

**Date:** 10/26/2020

**Content by:** Emma Neumann

**Present:** Emma Neumann

**Goals:** Investigate this sound board as a potential for the design since it was a recommendation from Dr. Numinkar.

**Content:**

- no microcontroller needed - although we would need one to regulate the buttons unless we did a dial
- 1.9" x 0.85"
- 16MB storage
- takes compressed Ogg files or uncompressed WAV files
- 44.1Hz 16 bit stereo
- 11 triggers
- 5 trigger effects
  - basic: play when connected to ground momentarily
  - hold: play when trigger is held down
  - latching: plays when pressed and stops when pressed again
  - play: play up to 10 files in consecutive order each time you press
  - random: play up to 10 files at random when pressed

<https://learn.adafruit.com/adafruit-audio-fx-sound-board>

**Conclusions/action items:**

This is a cool board, but I worry it won't have enough input options because we will probably want more than 11 sound files. Additionally, this would require an external bluetooth module to interact with an app, etc.



## DROK Bluetooth Audio Receiver

---

EMMA NEUMANN - Oct 26, 2020, 8:31 AM CDT

**Title:** DROK Bluetooth Audio Receiver

**Date:** 10/26/2020

**Content by:** Emma Neumann

**Present:** Emma Neumann

**Goals:** Find an audio board that can have more audio files than the Adafruit sound board and has a bluetooth capability

**Content:**

- audio inputs
  - bluetooth receiver up to 10-15 meters
  - USB decoding play
  - TF card decoding play
- DC5V
- operations
  - mode: switch between three audio inputs
  - next: play next sound, long press to increase volume
  - back: play previous sound, long press to decrease volume
  - eq: sound effect manager for USB or TF
  - audio output: for headphones, speaker, or amplifier

<https://www.droking.com/Bluetooth-Stereo-3.5mm-Audio-Receiver-Module-with-USB-TF-card-decoding-playback-preamp-output-for-MP3-WMA-WAV-FLAC>

[https://www.amazon.com/Bluetooth-DROK-Receiver-Electronics-Headphone/dp/B07P94Z9XR/ref=sr\\_1\\_5?dchild=1&keywords=Audio+Board&qid=1603717196&sr=8-5](https://www.amazon.com/Bluetooth-DROK-Receiver-Electronics-Headphone/dp/B07P94Z9XR/ref=sr_1_5?dchild=1&keywords=Audio+Board&qid=1603717196&sr=8-5)

**Conclusions/action items:**

This could solve the problem of not having enough audio files available, but I worry about the quality and reliability of using bluetooth.



EMMA NEUMANN - Mar 05, 2020, 9:51 AM CST



CBB635FE-2807-4187-AEAB-3F9BDE21EEB8.jpg(526.8 KB) - download

EMMA NEUMANN - Mar 05, 2020, 9:51 AM CST

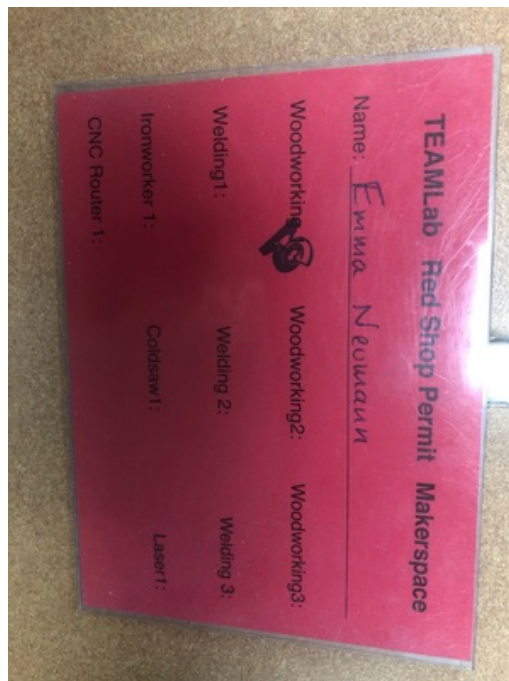

841EF188-C8E6-4025-995C-EBF231E0D312.jpg(514.9 KB) - download



EMMA NEUMANN - Apr 10, 2020, 5:17 PM CDT

410288 Certificate of Completion for EMMA NEUMANN

University of Wisconsin-Madison

This certifies that EMMA NEUMANN has completed training for the following course(s):

Course Name	Certificate or Quiz Name	Completion Date	Expiration Date
BIOSAFETY TRAINING A: SECURITY TRAINING	EMMA NEUMANN COURSE A: SECURITY TRAINING	04/10/2020	
BIOSAFETY TRAINING B: SECURITY TRAINING	EMMA NEUMANN COURSE B: SECURITY TRAINING	04/10/2020	
BIOSAFETY TRAINING C: SECURITY TRAINING	EMMA NEUMANN COURSE C: SECURITY TRAINING	04/10/2020	
BIOSAFETY TRAINING D: SECURITY TRAINING	EMMA NEUMANN COURSE D: SECURITY TRAINING	04/10/2020	
BIOSAFETY TRAINING E: SECURITY TRAINING	EMMA NEUMANN COURSE E: SECURITY TRAINING	04/10/2020	
BIOSAFETY TRAINING F: SECURITY TRAINING	EMMA NEUMANN COURSE F: SECURITY TRAINING	04/10/2020	
BIOSAFETY TRAINING G: SECURITY TRAINING	EMMA NEUMANN COURSE G: SECURITY TRAINING	04/10/2020	
BIOSAFETY TRAINING H: SECURITY TRAINING	EMMA NEUMANN COURSE H: SECURITY TRAINING	04/10/2020	
BIOSAFETY TRAINING I: SECURITY TRAINING	EMMA NEUMANN COURSE I: SECURITY TRAINING	04/10/2020	
BIOSAFETY TRAINING J: SECURITY TRAINING	EMMA NEUMANN COURSE J: SECURITY TRAINING	04/10/2020	
BIOSAFETY TRAINING K: SECURITY TRAINING	EMMA NEUMANN COURSE K: SECURITY TRAINING	04/10/2020	
BIOSAFETY TRAINING L: SECURITY TRAINING	EMMA NEUMANN COURSE L: SECURITY TRAINING	04/10/2020	
BIOSAFETY TRAINING M: SECURITY TRAINING	EMMA NEUMANN COURSE M: SECURITY TRAINING	04/10/2020	
BIOSAFETY TRAINING N: SECURITY TRAINING	EMMA NEUMANN COURSE N: SECURITY TRAINING	04/10/2020	
BIOSAFETY TRAINING O: SECURITY TRAINING	EMMA NEUMANN COURSE O: SECURITY TRAINING	04/10/2020	
BIOSAFETY TRAINING P: SECURITY TRAINING	EMMA NEUMANN COURSE P: SECURITY TRAINING	04/10/2020	
BIOSAFETY TRAINING Q: SECURITY TRAINING	EMMA NEUMANN COURSE Q: SECURITY TRAINING	04/10/2020	
BIOSAFETY TRAINING R: SECURITY TRAINING	EMMA NEUMANN COURSE R: SECURITY TRAINING	04/10/2020	
BIOSAFETY TRAINING S: SECURITY TRAINING	EMMA NEUMANN COURSE S: SECURITY TRAINING	04/10/2020	
BIOSAFETY TRAINING T: SECURITY TRAINING	EMMA NEUMANN COURSE T: SECURITY TRAINING	04/10/2020	
BIOSAFETY TRAINING U: SECURITY TRAINING	EMMA NEUMANN COURSE U: SECURITY TRAINING	04/10/2020	
BIOSAFETY TRAINING V: SECURITY TRAINING	EMMA NEUMANN COURSE V: SECURITY TRAINING	04/10/2020	
BIOSAFETY TRAINING W: SECURITY TRAINING	EMMA NEUMANN COURSE W: SECURITY TRAINING	04/10/2020	
BIOSAFETY TRAINING X: SECURITY TRAINING	EMMA NEUMANN COURSE X: SECURITY TRAINING	04/10/2020	
BIOSAFETY TRAINING Y: SECURITY TRAINING	EMMA NEUMANN COURSE Y: SECURITY TRAINING	04/10/2020	
BIOSAFETY TRAINING Z: SECURITY TRAINING	EMMA NEUMANN COURSE Z: SECURITY TRAINING	04/10/2020	

See a list of all courses at [https://www.wisc.edu/biosafety](#)

Print this certificate at [https://www.wisc.edu/biosafety](#)

Neumann\_BiosafetyTraining.pdf(136.2 KB) - [download](#)



# Abnormal Heart Rhythms

GABRIELLE SNYDER - Sep 17, 2020, 12:25 PM CDT

**Title:** Abnormal Heart Rhythms

**Date:** 9.17.20

**Content by:** Gabby

**Present:** me

**Goals:** To better understand what abnormal heart rates may look like

**Content:**

- normal heart rate = 60-100 bpm (beats per minute)
  - for athletic people it may be more close to 40-60 bpm

abnormal heart rhythms= arrhythmias

- signs:
  - skipping of a heart beat
  - fluttering sensation
  - or beating too slow (<60 bpm)
  - beating too fast (>100 bpm)
- caused when electrical impulses in heart are too fast, too slow, or irregular
- heart may pump blood inefficiently leading to poor blood circulation
  - result in organ damage
    - less oxygen reaching parts of body
- usually harmless
- some may produce symptoms
  - dizziness, palpitations, pounding in chest, fainting, shortness or breath, weakness, fatigue
- others may lead to sudden cardiac death if untreated
- **TYPES**
  - **Bradycardia**
    - heart beats too slow
      - <60 bpm
      - this may not cause problems or athletic people though
    - cause: disruption of electrical impulses from heart
    - factors:
      - aging,
      - hypothermia,
      - damage from heart attack or heart disease
  - **Tachycardia**
    - heart beats too fast
      - >100 bpm
    - cause: disruption of electrical impulses from heart
    - factors:
      - damage from heart attack or heart disease
      - congenital heart disease
      - high blood pressure
      - smoking
    - Atrial or Supraventricular Tachycardias
      - occurs in atria (upper chambers) or middle region
    - Sinus Trachycardia
      - heart functions properly but just has a faster heart rate
    - Ventricular Tachycardias
      - occurs in ventricles (lower chambers) of heart
      - may be life-threatening
  - **Fibrillation**
    - = heart quivers
    - Atrial Fibrillation
      - common abnormal heart rhythm
      - manageable



- Ventricular Fibrillation
  - life-threatening abnormal heart rhythm
- **Premature Contraction**
  - = early heart beat
  - Premature Atrial Contractions
    - PACs
    - occurs in artia
  - Premature Ventricular Contraction
    - PVCs
    - occurs in ventricles
- sometimes abnormal heart rhythms can be cured through medication however that is usually not the case
  - may be able to be controlled through use of medications

**Conclusions/action items:**

There are many different types of abnormal heart rhythms. Now that I have a better understanding of what different abnormal heart rates are, I can begin to research what they look like graphically and what they sound. I also like to know which kinds of heart rates are commonly found/used during mannequin simulations so we, as a team, can decide which/if any of these heart rates are ones we should consider for our design.

source: "Abnormal Heart Rhythms & Arrhythmia | MemorialCare", *Memorialcare.org*, 2020. [Online]. Available: <https://www.memorialcare.org/services/heart-vascular-care/abnormal-heart-rhythms-arrhythmias>. [Accessed: 17- Sep- 2020].



# How the Heart Works

GABRIELLE SNYDER - Sep 17, 2020, 1:06 PM CDT

**Title:** How the Heart Works

**Date:** 9.17.20

**Content by:** Gabby

**Present:** me

**Goals:** To develop a better understanding of how the heart works and how blood flows through the heart.

**Content:**

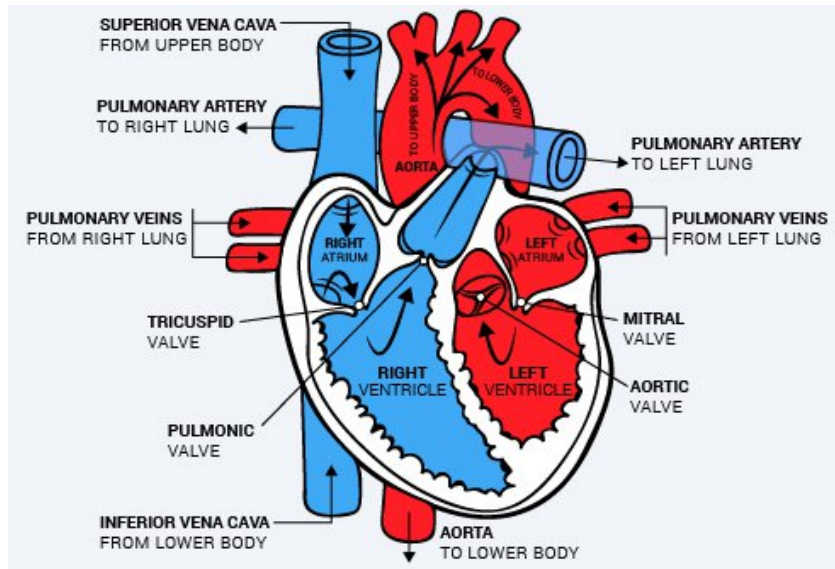

- **heart**
  - located under rib cage
  - 2/3 of it is to the left of the breastbone (sternum), between lungs and above diaphragm
  - size of closed fist, somewhat cone-shaped
  - about 10.5 oz
  - covered by pericardial sack (pericardium)
  - 4 chambers
- **heart arteries & their function**
  - septum (muscular wall) that divides heart into right and left side
  - atria= two top chambers (right & left atrium)
    - receive blood
    - then pump blood to ventricles
  - ventricles = two bottom chambers (right & left ventricles)
    - receive blood from atria
    - then pump blood to the lungs and body
  - coronary arteries
    - on heart surface
    - make up heart's mini-circulatory system
    - the two major coronary arteries branch off the aorta (near where aorta and left ventricle meet)
  - right coronary artery
    - supplies the right atrium and right ventricle with blood
    - branches to posterior descending artery
      - posterior descending artery supplies bottom portion of left ventricle and back of septum with blood
  - left main coronary artery
    - branches to circumflex artery and left anterior descending artery
      - circumflex artery - supplies blood to left atrium, and side and back of left ventricle
      - left anterior descending artery - supplies front and bottom of left ventricle and front of septum with blood

- these arteries supply blood to all parts of heart muscle
- **heart valves**
  - heart needs atria and ventricles to work sequentially
  - contracting and relaxing to pump blood out of heart and then allowing chamber to refill
  - there are 4 valves ,which prevent back flow of blood
    - Mitral valve
      - between left atrium and left ventricle
    - Tricuspid valve
      - between right atrium and right ventricle
    - Aortic valve
      - between left ventricle and aorta
    - Pulmonic valve (pulmonary valve)
      - between right ventricle and pulmonary artery
  - endocardium
    - membrane of epithelial cells
    - line heart chambers and valves
    - it a slick surface which prevents red blood cells, platelets, and other substances in blood from sticking to the inner surface of the heart
    - also contains Purkinje fibers
      - specialized muscle cells that can transmit electrical impulses
      - cause heart muscle contraction
  - SA (sinoatrial node)
    - or pacemaker
    - clusters of cells in upper right atrium
    - generate electrical impulses
  - AV node
    - atrioventricular node
    - cluster of cells at center of heart between bottom of right atria and top of ventricles
    - where the electrical impulses from the SA move toward after being generated
    - it pauses the electrical impulse to allow the atria to fully contract (ie squeeze blood out into ventricles)
    - then allows the impulse "to go into cells termed the bundle of His to the ventricles that split into the right and left bundle branches in the ventricles"
    - the signal then reaches the Perkinje fibers and causes the ventricles to contract and push blood into the lungs and aorta
  - ventricular contractions generate heart rates (pulse) and blood pressures
    - body's nervous system controls the impulse rate in the SA node

## THE HEART (cont)

### How blood flows through heart

- veins carry deoxygenated blood to the heart
- arteries carry oxygenated blood away from the heart
- RIGHT SIDE
  - inferior and superior vena cava (both veins) carry deoxygenated blood to the right atrium
  - right atrium contracts
  - blood flows into right ventricle through tricuspid valve
    - when ventricle is full, valve shuts (right atrium contract again)
  - right ventricle contracts
  - blood flows through pulmonic valve into pulmonary artery and lungs
  - blood oxygenated in the lungs ("CO<sub>2</sub> released and O<sub>2</sub> absorbed")
- LEFT SIDE
  - oxygen-rich blood enters left atrium through the pulmonary vein
  - left atrium contracts
  - blood flows into left ventricle through mitral valve
    - when ventricle is full, valve shuts (left atrium contracts again)
  - left ventricle contracts
  - oxygenated blood leaves heart through aortic valve, into the aorta and to arteries , distributed to rest of body
  - blood eventually enters veins to repeat this process and complete blood circulation in body

### Conclusions/action items:

Having a better understanding of the different parts and functions of the heart as well as how the heart functions and the way blood flows through the heart will be beneficial in understanding how heart rates/pulses are created. It could also help me be able to identify what issues in the functioning occur to cause arrhythmias. More research will need to be done of what specifically occurs in the heart functions that causes the different arrhythmias.

source: "How the Heart Works: Diagram, Anatomy, Blood Flow", *MedicineNet*, 2020. [Online]. Available:

[https://www.medicinenet.com/heart\\_how\\_the\\_heart\\_works/article.htm#which\\_drugs\\_or\\_supplements\\_interact\\_with\\_evolocumab](https://www.medicinenet.com/heart_how_the_heart_works/article.htm#which_drugs_or_supplements_interact_with_evolocumab). [Accessed: 17-Sep- 2020].



## Sterilizable Materials

GABRIELLE SNYDER - Sep 23, 2020, 12:15 AM CDT

**Title:** Sterilizable Materials for a vest design

**Date:** 9.22.20

**Content by:** Gabby

**Present:** me

**Goals:** To try to find different materials that could be used to create our design idea out of.

**Content:**

fabrics

- magnafabrics.com
  - maxima ESD
    - high density polyester static dissipative fabric
    - fabric repels fluid and bacteria
    - recommended for: aseptic environments, pharmaceutical, biotechnical, biological and food processing
    - Mean Size: 5-6 microns
    - Weight: 2.53 oz/yd<sup>2</sup>
    - Air Permeability: 1.21 cfm/ft<sup>2</sup>
    - Moisture Vapor Transmission: 1350 g/m<sup>2</sup>/24 hr
    - Carbon: Stripe Surface Resistivity: 4.85×10<sup>7</sup> ohms/sq
    - Static Decay: 0.01 sec Static
    - machine washable autoclavable
    - grade 2
  - maxima (medical barrier)
    - Mean Pore Size: 5-6 microns
    - Weight: 2.53 oz/yd<sup>2</sup>
    - Air Permeability: 1.21 cfm/ft<sup>2</sup>
    - Moisture Vapor Transmission: 1350 g/m<sup>2</sup>/24 hr
    - machine washable, autoclavable, gamma compatible
    - grade 2

**Conclusions/action items:**

I am not sure it would actually be feasible to create our design completely out of these sterilizable plastics. However, it could possibly work for us to create our design, say a vest, out of polyester or some kind of more comfortable fabric and then just create a second, outer layer of some kind of sterilizable plastic that would go on top of the other material. This would make our design more durable and probably more comfortable to wear too and it would also provide a way to easily clean the device between each use.

fabrics citation: "Medical Barrier Fabrics for Surgical Gowns, Isolation Gowns, Surgical", *Magna Fabrics*, 2020. [Online]. Available: <https://www.magnafabrics.com/collections/medical-barrier-fabrics/autoclavable-fabric>. [Accessed: 23- Sep- 2020].



# Sterilizable Plastics

GABRIELLE SNYDER - Sep 23, 2020, 12:43 AM CDT

**Title:** Sterilizable Materials for a vest design

**Date:** 9.22/23.20

**Content by:** Gabby

**Present:** me

**Goals:** To try to find different plastic materials that could be used to create our design.

**Content:**

- polymer used should be a thermoplastic material
- thermoplastic
  - type of synthetic polymer
  - can be reheated and remodeled without irreversible degradation
  - undergo physical changes, not chemical
  - can be reused and recycled
  - good for plastic injection molding
- medical grade polymers
  - must be biocompatible
  - temperature, impact, and corrosion resistant
- types thermoplastic materials
  - polycarbonates
    - impact resistance properties
    - withstand high-temperature ranges
      - good heat resistant properties
    - used for plastic lenses, car components, protective gear
    - pliable and can be formed at room temp without cracking or breaking
  - polypropylene
    - used when steam-sterilized devices are needed
    - chemical/corrosion resistant
    - durable
      - high strength to weight ratio
      - high impact strength
    - recyclable
  - polyethylene
    - high impact resistance
    - high resistance to chemicals
    - low moisture absorption
    - does not fade
    - does not retain dangerous bacteria
    - can withstand cleaning agents

**Conclusions/action items:**

These are potential plastics that we could look into using in our design if there needs to be an aspect that would be best if made out of plastic. The center circle plate in my second design could potentially be created out of one of these plastics too. We need to use materials that are sterilizable because many different people would be practicing scenarios on the same design so it is imperative (especially now with COVID) that the device can be adequately cleaned between each use.

source: B. MEDICAL, "What are the Best Types of Plastic for Medical Equipment or Devices?", *BMP Medical*, 2020. [Online]. Available: <https://www.bmpmedical.com/news/what-plastics-are-used-in-medical-devices/>. [Accessed: 23- Sep- 2020].



**Title:** Manikin Research

**Date:** 9.9.20

**Content by:** Gabby

**Present:** me

**Goals:** To understand the SimMan that is currently being used

**Content:**

- manikin (mannequin)
  - used in situations ranging from emergencies to military simulations to surgeries
  - simulate human anatomy and physiology
- fidelity = "degree to which a particular manikin can reproduce or mimic human physiology"
  - high fidelity --> those that most closely resemble human anatomy
    - expanding chests (breathe)
    - varying heart rates and tones
    - able to measure blood pressure
    - pulses
    - EKG displays
    - pulse oximeter
    - arterial and pulmonary artery wave forms
    - anesthetic gases
    - able to perform procedures on these types of manikins
      - bag-mask ventilation, intubation, defibrillation, chest tube placement, cricothyrotomy
    - usually contain hydraulics, compressors, external displays
    - may change color, speak, cry
    - undergo seizures
    - some are specialized
      - ie trauma manikins, birthing manikins, newborn and/or premature babies
    - usually operated by trained person from a separate room
      - another person may be in the room with the student to help them through the scenario
    - more than one company makes these
      - SimMan series
      - LucinaAR birthing simulator from CAE Healthcare
        - has hologram options
      - Victoria birthing manikin by Gaumard
  - low fidelity --> little resemblance to human anatomy
    - static manikins with limited functionality
    - aka task trainers
    - used for repeated practice
      - ex. catheter placement

**Conclusions/action items:**

There are many different elements that can be implemented into a manikin. However, as a team we would not be able to create/implement every single data piece and sound. We need to ask our client what the most important aspects of the manikin are and try to design all or some of those this semester and possibly adding other components in future semesters.

source: HealthySimulation.com. 2020. *High Fidelity Simulation | Healthcare Simulation | Healthysimulation.Com.* [online] Available at: <<https://www.healthysimulation.com/high-fidelity-simulation/>> [Accessed 10 September 2020].

 **Idea #1**

GABRIELLE SNYDER - Sep 22, 2020, 11:35 PM CDT

**Title:** Design Idea 1**Date:** 9.22.20**Content by:** Gabby**Present:** me**Goals:** Design and illustrate a rough sketch of my first design idea**Content:**

GABRIELLE SNYDER - Sep 22, 2020, 11:36 PM CDT

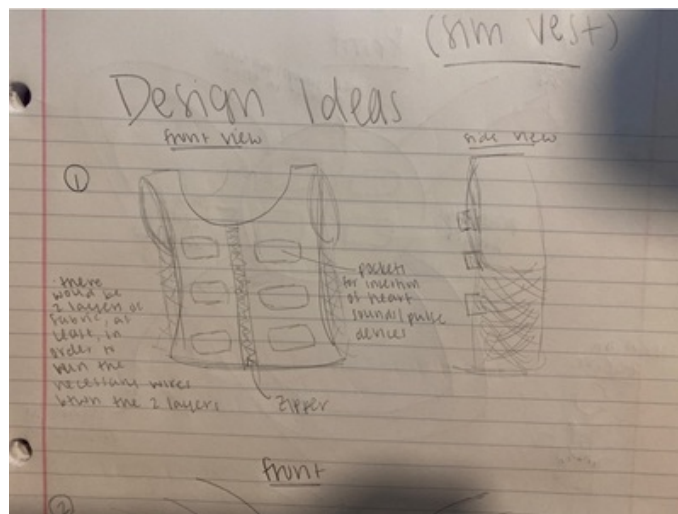
**design\_idea\_1.jpg(128.8 KB) - download**

GABRIELLE SNYDER - Sep 22, 2020, 11:40 PM CDT

**Conclusions/action items:**

This design uses the look and fit of a weighted vest. However, instead of weights in the pockets we could put the different sensors we want to use in them. There would be a double layer of fabric so if wires are needed we could run the wires between the two layers so they do not hang out and get in the way. The vest could be zipped up the front and there can also be straps on the side in order to make it adjustable.



 **Idea #2**

GABRIELLE SNYDER - Sep 22, 2020, 11:40 PM CDT

**Title:** Design Idea 2**Date:** 9.22.20**Content by:** Gabby**Present:** me**Goals:** Design and illustrate a rough sketch of my second design idea**Content:**

GABRIELLE SNYDER - Sep 22, 2020, 11:29 PM CDT

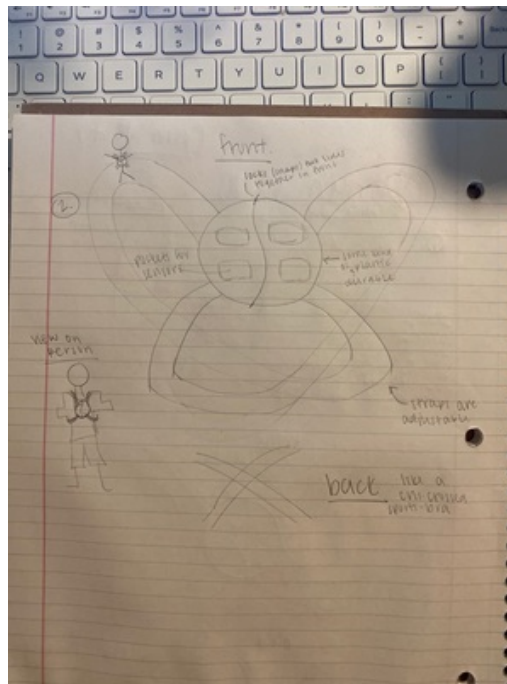
**Design\_idea\_2.jpg(128.3 KB) - [download](#)**

GABRIELLE SNYDER - Sep 22, 2020, 11:55 PM CDT

**Conclusions/action items:**

This design involves a "breastplate" (I'm not really sure exactly what to call it) but ideally it will sit right around the chest/pec/breast area of the wearer. The plastic piece would be made of two halves that can clasp together. The straps attach to the plastic circle piece, loop over the shoulder, and cross in the back. The straps can also be adjustable to allow for different sized wearers. The different sensors can be placed either inside the plastic piece or on the front facing face. My concern with this design is that there is not enough surface area of wearable device for a student to use/practice on. With this device the student would most likely have to directly touch the wearer to practice whereas in the other design the student would be touching the vest being worn.

GABRIELLE SNYDER - Oct 04, 2020, 10:25 PM CDT

**Title:** Sim Lab Manikin Photos**Date:** 10.4.20**Content by:** Gabby**Present:** Emma, Tim, and Caroline**Goals:** To see an adult manikin in person and to learn more about what they do and how they work**Content:**

GABRIELLE SNYDER - Oct 04, 2020, 10:34 PM CDT



**Neck\_Area\_Pulse\_.jpg(128 KB) - download** This is the neck/head area of the manikin. Emma's fingers are touching the air compressor which is the source of generating a pulse in the neck. While an air compressor may be difficult for us to implement, one option would be use to some type of spring loaded mechanism to generate pulses.

GABRIELLE SNYDER - Oct 04, 2020, 10:36 PM CDT



**Inside\_of\_skin\_flap.jpg(128.9 KB) - download** This is an image of the inside of the "skin" flap which covers all the electronic/inside parts of the manikin. The circular areas are where different chips can be inserted in order to practice ultrasounds (I believe).

GABRIELLE SNYDER - Oct 04, 2020, 10:43 PM CDT



**Chest\_Area\_of\_manikin.jpg(156.6 KB) - download** This is a picture of what is underneath the chest area of the manikin. Where the hand is in the picture is the chest piece of the manikin which rises and falls to simulate a normal (and abnormal) breathing. The manikin also generates breathing sounds which correlate to the rate of breathing occurring. There are also speakers on the breast plate which allow for one to listen the manikin's "heart" via a stethoscope. I do not think it can be seen in this picture but there are metal leads on the chest which also allow for the manikin to be connected to an AED and another device where one could actually change the different heart/lunge/pulse sounds/rates to correspond to a different situation; they specific wave and vital number are then displayed on the screen.

**Conclusions/action items:**

This adult manikin that we were shown is a very impressive piece of equipment and there are a lot of different things it can do. It does look very dead so I can see why Dr. Lohmeier would like us to create a vest for someone to wear in order to make running scenarios more realistic. For this semester, our main goal is to create a vest that can generate heart and lung sounds, as these two components seem to be the most important. Dr. Lohmeier did mention that it may be beneficial for the person wearing the vest to have the ability to adjust its "settings" instead of a second person controlled the vest. As a team, we need to figure out the exact design/layout of our vest, what material we want to make the vest out of, and what kinds of electronic components we need for our speaker systems/

# Block Diagrams for Prelim Designs

GABRIELLE SNYDER - Oct 07, 2020, 9:53 AM CDT

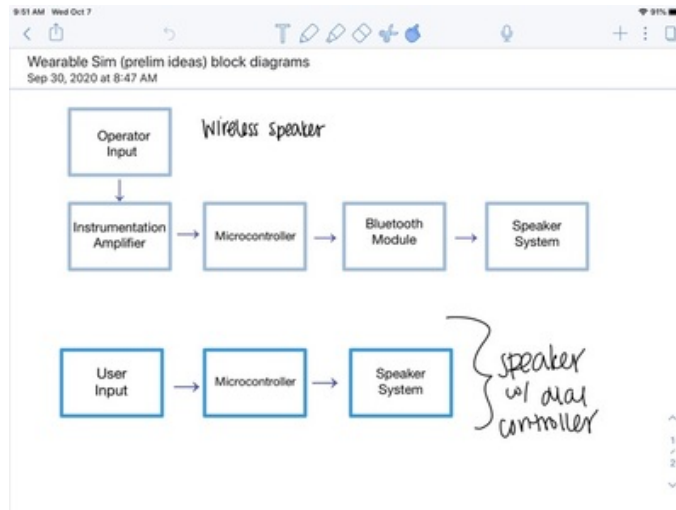

block\_diagrams\_1\_2.jpg(47.7 KB) - [download](#)

GABRIELLE SNYDER - Oct 07, 2020, 9:53 AM CDT

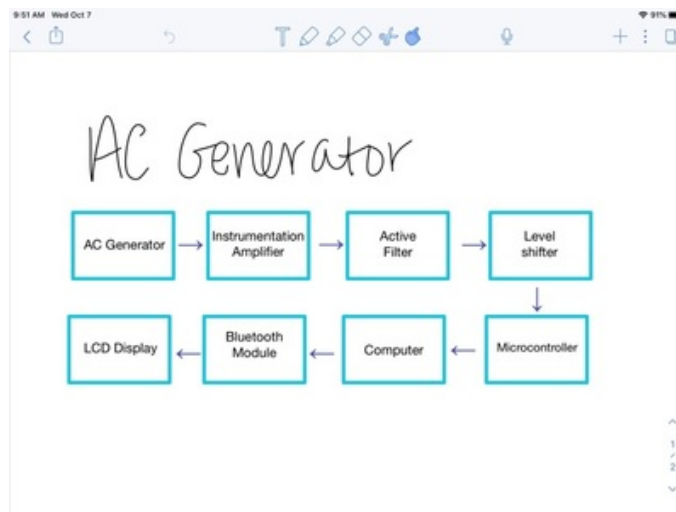

block\_diagram\_3.jpg(43.5 KB) - [download](#)

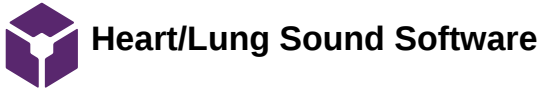

GABRIELLE SNYDER - Oct 15, 2020, 2:41 PM CDT

**Title:** Possible Software for Heart & Lung Sounds

**Date:** 10.15.20

- **Content by:** Gabby

**Present:** Gabby

**Goals:** To see if there is any downloadable software that will produce heart and lung sounds

**Content:**

- a term for this software is computer-aided auscultation (CAA)
- found a journal on a software called Computerized Lungs Auscultation- Sound Software (CLASS) but could not find any place to download it
  - I am not sure if this software is even on the market yet
- I did find a software by Gaumard
  - S182 Heart and Lung Sounds Software - Adult
  - cost = \$99
  - features include
    - normal and abnormal heart and lung sounds
    - 12 heart and 9 lung sounds for adults
    - 15 heart and 9 lungs sounds of children
    - virtual stethoscope
  - <https://www.gaumard.com/s182>
- there is also: 3M Littmann StethAssist Heart and Lung Sound Visualization Software
  - use to record, save, playback & view sounds
  - can transmit and receive heart and lung sounds using Bluetooth
  - sounds can be recorded directly by their model 3200 stethoscope downloaded from its memory
    - \*\*unclear if there are prerecorded sounds!
    - this could be an issue
  - [https://www.littmann.com/3M/en\\_US/littmann-stethoscopes/my-stethoscope/using-your-stethoscope/steth-assist/](https://www.littmann.com/3M/en_US/littmann-stethoscopes/my-stethoscope/using-your-stethoscope/steth-assist/)
- 

**Conclusions/action items:**

We could potentially download a software that will produce heart and lung sounds for us. However, I am still unsure if such a software exists that we could actually use to fit our needs. Future research should be done into these products, and we should also discuss as a team our thoughts about the software and if it will be of use.

 **Potential Speakers for Our Design**

GABRIELLE SNYDER - Oct 22, 2020, 2:41 PM CD1

**Title:** Speaker Ideas

**Date:** 10.22.20

**Content by:** Gabby

**Present:** me

**Goals:** To try to find different speakers that we could buy to use for our design.

**Content:**

- SP-1504



- - general purpose speaker top round
  - from digi-key
  - \$2.95
  - could use to connect to the Adafruit Audio FX Sound Board
  - 8 Ohm
  - 800 MW
  - top port 09 dB
  - 1000 Hz sound
  - would probably hook this up directly to the circuit board
  - <https://www.digikey.ca/en/products/detail/soberton-inc/SP-1504/3973690>

- CUI devices micro speakers
  - Compact sizes from 10 mm to 18 mm
  - Depths as low as 2 mm
  - Sound pressure levels (SPL) from 82 dB to 93 dB
  - Input power as low as 0.2 W
  - Mylar cone design
  - Wire lead, surface mount, spring terminal, PCB, and solder pad mounting configurations
  - <https://www.digikey.com/en/product-highlight/c/cui/micro-speakers>

- Black Mirco Dot Wireless Speaker



- - 1.5" diameter and 1" tall
  - this is wireless so we could set it up to connect to a computer and then place it in a vest pocket to produce sounds
  - only has a 1.5 hour play time through
  - \$15.99
  - [https://www.littleobsessed.com/black-micro-dot-wireless-speaker/?gclid=EAlaIqobChMljj35PLI7AIVa\\_7jBx05FQRrEAQYCSABEGkwvPD\\_BwE](https://www.littleobsessed.com/black-micro-dot-wireless-speaker/?gclid=EAlaIqobChMljj35PLI7AIVa_7jBx05FQRrEAQYCSABEGkwvPD_BwE)

- Ultra Slim Wireless Speaker



- - 4" W x 2" H x .5" D
  - up to 3 hours of play time
  - 250 mAh lithium ion battery
  - pairs from up to 25ft away
  - \$13.99
  - [https://www.ideastage.com/Ultra-Slim-Wireless-Speaker-355990588?gclid=EAlaIqobChMljiI06PXI7AIVCYizCh1zagcUEAQYECABEGl7p\\_D\\_BwE](https://www.ideastage.com/Ultra-Slim-Wireless-Speaker-355990588?gclid=EAlaIqobChMljiI06PXI7AIVCYizCh1zagcUEAQYECABEGl7p_D_BwE)

- Zulu Audio Alpha Wearable Speakers



- - Product dimensions: 1.83"W x 0.75"T x 25.68"L
  - Bluetooth
  - Range: class 2, up to 16.4ft
  - Frequency range: 2402-2480MHz
  - Operating temperature: 14°F - 140°F
  - Power input: 5V 1A
  - Rechargeable battery: 200mAh

- Charging time: 2.5 hours
- Battery life: 4 hours at 75% volume
- Total power output: 2W x 2
- Frequency response: 40Hz ~20kHz
- Water/splash resistance: IPX4
- \$42.99
- [https://shop.popsoci.com/sales/wearable-speakers-white?utm\\_source=google&utm\\_medium=cpc&utm\\_campaign=8754794779&utm\\_term=&gclid=EAlalQobChMijliO6PXI7AIVCYizCh1zagcUEAQYGyABEgLk7PD\\_BwE](https://shop.popsoci.com/sales/wearable-speakers-white?utm_source=google&utm_medium=cpc&utm_campaign=8754794779&utm_term=&gclid=EAlalQobChMijliO6PXI7AIVCYizCh1zagcUEAQYGyABEgLk7PD_BwE)
- this are kind of expensive, however I like how they look
- we could potentially buy two of these --> one for the front and one for the back of the vest

**Conclusions/action items:**

There are different options for speakers out there on the market. As a team we need to decide exactly what size of speaker we would like to use. I am thinking a Bluetooth speaker may make the most sense as the speaker could be put with the vest and then controlled remotely via a computer. However, Bluetooth do not seem to have super long battery lives meaning they will probably have to be charged very regularly, probably anytime the vest is not being used. It would not be very good if the speaker died during the simulations.





## Ideas for Potential Vests

GABRIELLE SNYDER - Nov 12, 2020, 3:41 PM CST

**Title:** Potential Vest Ideas

**Date:** 11.12.20

**Content by:** Gabby

**Present:** me

**Goals:** To research different vests on the market that we could buy to use as the vest the person acting out the scenario will wear for our design.

**Content:**

### hyper vest elite weight vest

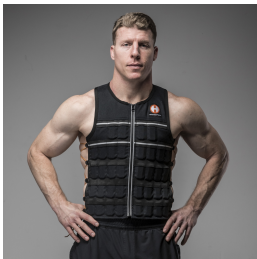

- this vest is very expensive
  - \$197.99
- however, I do like the design as it is form fitting and not very bulky
- has side lacing for adjustable fit
- it is a weight vest but in my mind we could place our speakers and circuit boards where the weights would normally go
- there are also spots on the back were we could add the speakers too
  - negative: would have to remove the weights that are already present in the design , which could also be a pain
- [https://www.hyperwear.com/product/weighted-vest/?attribute\\_size=X-Large&attribute\\_weight=10+LBS&gclid=CjwKCAiA17P9BRB2EiwAMvwNyOI\\_pScT0iLy\\_-keKjImXR5bYbfgso0U8AeuKbnfPpsdwGMxLyWMIRoC6ccQAvD\\_BwE](https://www.hyperwear.com/product/weighted-vest/?attribute_size=X-Large&attribute_weight=10+LBS&gclid=CjwKCAiA17P9BRB2EiwAMvwNyOI_pScT0iLy_-keKjImXR5bYbfgso0U8AeuKbnfPpsdwGMxLyWMIRoC6ccQAvD_BwE)

### Peregrine Field Gear Trekker Dog Handler's Vest V2.0



- this vest has front and back pockets
- is lightweight
- \$169.99
- however, it is only available on this website in small and medium
  - large and x-large are sold out which could be an issue
- <https://www.peregrinefieldgear.com/store/p/1140-NEW-Peregrine-Field-Gear-Trekker-Dog-Handler-Vest.aspx>

### waterproof pisfun fishing vest outdoor photography hiking, hunting, multi-pocket vest (vest men's fishing jacket)



- currently \$38 on amazon
  - issue: it says will arrive between dec 4-28
  - maybe will come in sooner from a different website but I am currently not seeing anything
- lightweight
- could put our speak in the front pockets
- the back pocket looks very large but maybe we could somehow attach (sew?) the speakers/circuit boards to the back pocket
- <https://www.amazon.com/Berrykey-Waterproof-Fishing-Outdoor-Waistcoat/dp/B0819GRRRCQ>

**Conclusions/action items:**

These are some initial vest ideas. However, I do not really love any of these options so I will need to do some for vest research to see if I can find any better/more suitable vest designs. If I did have to choose, out of all of these, I like the hyper vest design the best as it as the most options for choosing which place we would like to place our speakers and it is also the least bulky design.

---

GABRIELLE SNYDER - Dec 01, 2020, 6:59 PM CST

additional link for hypervest from Rogue fitness: [https://www.roguefitness.com/hyper-vest-elite-weight-vest?160=3529&287=3581&gclid=CjwKCAiA8Jf-BRB-EiwAWDtEGuU2LEooie-NRG\\_3MOTCp2Tq8ohTWPt-dAy-Rfdv\\_CFXsTwtcae8CRoCuW0QAvD\\_BwE](https://www.roguefitness.com/hyper-vest-elite-weight-vest?160=3529&287=3581&gclid=CjwKCAiA8Jf-BRB-EiwAWDtEGuU2LEooie-NRG_3MOTCp2Tq8ohTWPt-dAy-Rfdv_CFXsTwtcae8CRoCuW0QAvD_BwE)

**Title:** Theoretical Final Design

**Date:** 12.3.20

**Content by:** Gabby

**Present:** me (Emma helped with the final design illustration)

**Goals:** To illustrate what our final design would have looked like if we had the time and materials to fabricate it

**Content:**

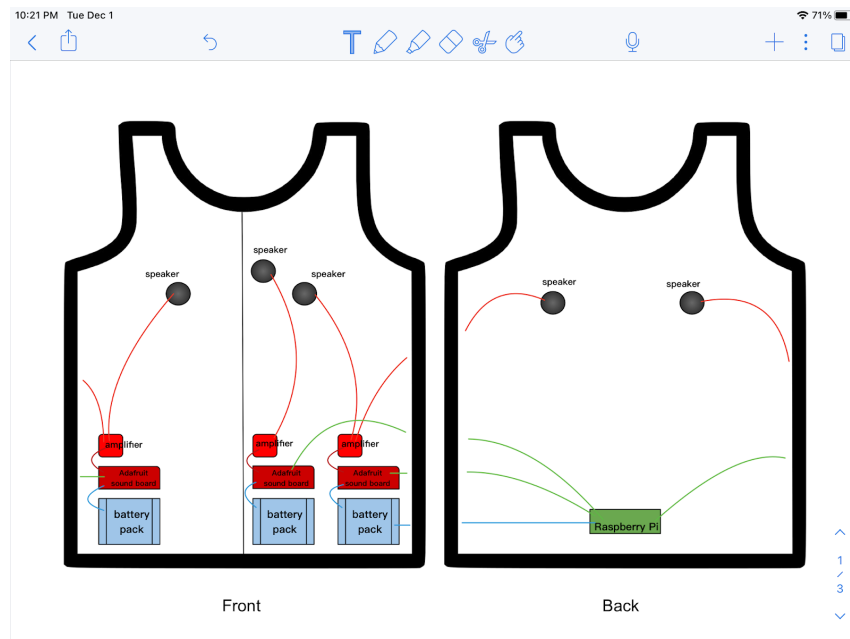

*Figure 7:* This is an illustration of the placement of the electronic components in the vest including the speakers, amplifiers, sound boards, battery packs, raspberry pi, and communication via connection wires.

**Conclusions/action items:**

This is our current final design idea that we in theory would have worked on fabricating if the materials came in and if this overall had been a different semester and we could have meet in person as a team. During the actual fabrication we may run into unforeseen issues that may cause us to slightly alter our design idea.



GABRIELLE SNYDER - Feb 02, 2020, 10:42 PM CST

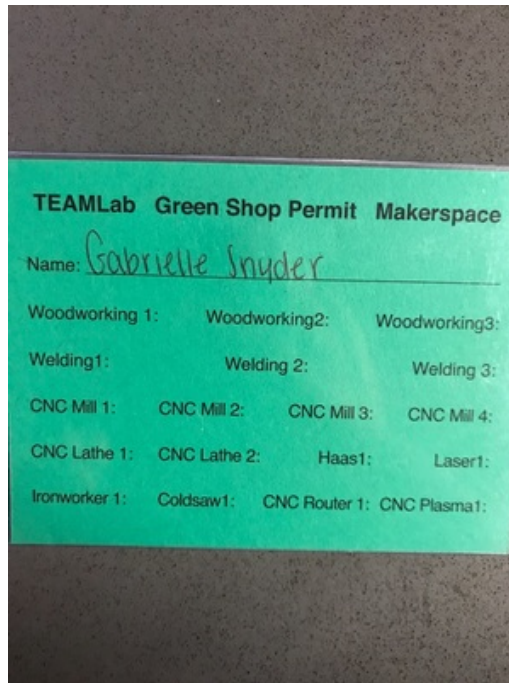

Gree\_Permit\_front\_.jpg(179.6 KB) - download

GABRIELLE SNYDER - Feb 02, 2020, 10:43 PM CST



Green\_Permit\_back.jpg(197.5 KB) - download



# BioSafety Training Cert

GABRIELLE SNYDER - Mar 20, 2020, 3:22 PM CDT

← → ↻ my.gradsch.wisc.edu/lookups/citi/courseList.pl?e=GESNYDER@WISC.EDU ☆ 6

## University of Wisconsin-Madison

This certifies that GABRIELLE SNYDER has completed training for the following course(s):

Course Name	Curriculum or Quiz Name	Completion Date	Expiration Date
BIOSAFETY REQUIRED TRAINING	BIOSAFETY REQUIRED TRAINING QUIZ	3/17/2020	

Data Effective: Tue Mar 17 23:52:52 2020  
Report Generated: Fri Mar 20 15:08:35 2020



## 10/04/20 Heart Rhythms and Signals

RUSHABH TOLIA - Oct 04, 2020, 1:21 AM CDT

**Title:** Heart Rhythms and Signal Strength

**Date:** 10/04/20

**Content by:** Rushabh Tolia

**Present:** N/A

**Goals:** To understand the functions of the heart, abnormal heart findings, and how the sounds and signals are attenuated.

**Content:**

- The heart has four chambers:
  - The right atrium receives blood from the veins and pumps it to the right ventricle.
  - The right ventricle receives blood from the right atrium and pumps it to the lungs, where it is loaded with oxygen.
  - The left atrium receives oxygenated blood from the lungs and pumps it to the left ventricle.
  - The left ventricle (the strongest chamber) pumps oxygen-rich blood to the rest of the body. The left ventricle's vigorous contractions create our blood pressure.
- **Coronary artery disease:** Over the years, cholesterol plaques can narrow the arteries supplying blood to the heart. The narrowed arteries are at higher risk for complete blockage from a sudden blood clot (this blockage is called a heart attack).
- **Stable angina pectoris:** Narrowed coronary arteries cause predictable chest pain or discomfort with exertion. The blockages prevent the heart from receiving the extra oxygen needed for strenuous activity. Symptoms typically get better with rest.
- **Unstable angina pectoris:** Chest pain or discomfort that is new, worsening, or occurs at rest. This is an emergency situation as it can precede a heart attack, serious abnormal heart rhythm, or cardiac arrest.
- **Myocardial infarction (heart attack):** A coronary artery is suddenly blocked. Starved of oxygen, part of the heart muscle dies.
- **Arrhythmia (dysrhythmia):** An abnormal heart rhythm due to changes in the conduction of electrical impulses through the heart. Some arrhythmias are benign, but others are life-threatening.
- **Congestive heart failure:** The heart is either too weak or too stiff to effectively pump blood through the body. Shortness of breath and leg swelling are common symptoms.
- **Cardiomyopathy:** A disease of heart muscle in which the heart is abnormally enlarged, thickened, and/or stiffened. As a result, the heart's ability to pump blood is weakened.
- **Myocarditis:** Inflammation of the heart muscle, most often due to a viral infection.
- **Pericarditis:** Inflammation of the lining of the heart (pericardium). Viral infections, kidney failure, and autoimmune conditions are common causes.
- **Pericardial effusion:** Fluid between the lining of the heart (pericardium) and the heart itself. Often, this is due to pericarditis.
- **Atrial fibrillation:** Abnormal electrical impulses in the atria cause an irregular heartbeat. Atrial fibrillation is one of the most common arrhythmias.
- **Pulmonary embolism:** Typically a blood clot travels through the heart to the lungs.
- **Heart valve disease:** There are four heart valves, and each can develop problems. If severe, valve disease can cause congestive heart failure.
- **Heart murmur:** An abnormal sound heard when listening to the heart with a stethoscope. Some heart murmurs are benign; others suggest heart disease.
- **Endocarditis:** Inflammation of the inner lining or heart valves of the heart. Usually, endocarditis is due to a serious infection of the heart valves.
- **Mitral valve prolapse:** The mitral valve is forced backward slightly after blood has passed through the valve.
- **Sudden cardiac death:** Death caused by a sudden loss of heart function (cardiac arrest).
- **Cardiac arrest:** Sudden loss of heart function.

### Heart Tests

- **Electrocardiogram (ECG or EKG):** A tracing of the heart's electrical activity. Electrocardiograms can help diagnose many heart conditions.
- **Echocardiogram:** An ultrasound of the heart. An echocardiogram provides direct viewing of any problems with the heart muscle's pumping ability and heart valves.
- **Cardiac stress test:** By using a treadmill or medicines, the heart is stimulated to pump to near-maximum capacity. This may identify people with coronary artery disease.

- **Cardiac catheterization:** A catheter is inserted into the femoral artery in the groin and threaded into the coronary arteries. A doctor can then view X-ray images of the coronary arteries or any blockages and perform stenting or other procedures.
- **Holter monitor:** If a doctor suspects an arrhythmia, a portable heart monitor can be worn. Called a Holter monitor, it records the heart's rhythm continuously for a 24 hour period.
- **Event monitor:** If a doctor suspects an infrequent arrhythmia, a portable heart monitor called an event monitor can be worn. When you develop symptoms, you can push a button to record the heart's electrical rhythm.

**Conclusions/action items:**

The point of this article was to understand the components of the heart and know if a failure in a part of an artery or vein in heart signifies what type of action. For our project it will be very important to go in depth into how different functions of the heart may be altered because of an irregular beating of the heart and what it may signify for a patient. In addition, it will be very important to know how the electrocardiogram will map those heart signals, so the group understands the distribution of electrical signals. From this article it was found to be important that our vest must be designed to display symptoms of heart murmurs, arrhythmia and atrial fibrillation, as our vest will need to output irregular and regular heart signals. Also, the intensity of those sounds will be important, because in some patients, those sounds will be easier to hear than in others. In addition, it will be worth to look into how a circuit can be used to make electrical signals that a monitor can read.

Hoffman, M. (2019, May 17). Human Heart (Anatomy): Diagram, Function, Chambers, Location in Body. Retrieved October 04, 2020, from <https://www.webmd.com/heart/picture-of-the-heart>



# 10/05/20 Lung Sounds and Irregular Breathings

RUSHABH TOLIA - Oct 05, 2020, 11:59 PM CDT

## Title: Lung Sounds and Irregular Breathing Problems

**Date:** 10/05/20

**Content by:** Rushabh Tolia

**Present:** N/A

**Goals:** How lung sounds tell whether a lung is being affected by an ailment.

### Content:

Breath sounds come from the lungs when you breathe in and out. These sounds can be heard using a stethoscope or simply when breathing.

- Breath sounds can be normal or abnormal. Abnormal breath sounds can indicate a lung problem, such as
- obstruction
- inflammation
- infection
- asthma
- fluid in lungs

A normal breath sound is similar to the sound of air. However, abnormal breath sounds may include:

- rhonchi (a low-pitched breath sound)
- crackles (a high pitched breathing sound)
- wheezing (a high-pitched whistling sound caused by narrowing of the bronchial tubes)
- stridor (a harsh, vibratory sound caused by narrowing of the upper airway)

Abnormal breath sounds are usually indicators of problems in the lungs or airways. The most common causes of abnormal breath sounds are:

- pneumonia
- heart failure
- chronic obstructive pulmonary disease (COPD), such as emphysema
- asthma
- bronchitis
- foreign body in the lungs or airways

The doctor will order one or several tests to determine what's causing the abnormal sound. These tests can include:

- CT scan
- chest X-ray
- blood tests
- pulmonary function test
- sputum culture

Your doctor can use a pulmonary function test to measure:

- how much air you inhale and exhale
- how efficiently you inhale and exhale

A sputum culture is a test for detecting foreign organisms in the mucus of the lungs, such as abnormal bacteria or fungi. For this test, your doctor asks you to cough and then collects the sputum you cough up. This sample is then sent to a lab for analysis.

### Conclusions/action items:

There are many different conditions that affect breathing sounds, however some of these conditions affect breathing in the same way, but it is possible to increase or decrease its sound to make it be more apparent that a certain condition is present in the vest. Next research needs to be done on how breathing sounds can come out of the vest from a circuit. It is possible to use sounds already made by these patients have a circuit relay those sounds to make it be as most realistic as possible. It may be possible to convert those sounds to mp3 files and then have them connected via a circuit to an output device, a speaker, that will then have those sounds come out.

Kahn, A. (2019, September 18). Breath Sounds: Types, Causes, and Treatments. Retrieved from <https://www.healthline.com/health/breath-sounds>







## 09/18/20 Lateral SimMan 3G

RUSHABH TOLIA - Oct 06, 2020, 6:50 PM CDT

**Title:** Technical components concerning current patient medical simulators

**Date:** 09/09/20

**Content by:** Rushabh Tolia

**Present:** n/a

**Goals:** To understand possible components that can be integrated into our proposed design from other advanced models of medical simulators.

**Content:**

- Laerdal has a SimMan 3G which is an advanced patient simulator that can display neurological symptoms as well as physiological. It is simple to operate and features innovative technology such as automatic drug recognition.



- The above pic is a very realistic model for a simulator by having human characteristics
- Using SimMan 3G alone, or together with more advanced training options such as ultrasound, or ventilation management, a clinical patient monitor and video debriefing systems
- LLEAP unifies the operation of all PC operated Laerdal simulators by providing a shared user interface, interchangeable hardware options, and a cohesive simulation experience. You are in full control to plan, run and assess simulation sessions
- Completely wireless and self-contained
- Internal electrical and pneumatic power
- Supplemental wired connectivity and power
- Wirelessly integrates with existing computer networks
- Swappable, rechargeable batteries
- Approximately 4 hours continuous operation in wireless mode
- Rugged and reliable for use in multiple environments
- Controllable open/closed airway; automatically or manually controlled
- Transtracheal jet ventilation
- Needle cricothyrotomy
- Surgical cricothyrotomy
- Variable lung compliance
  - 4 settings
- Variable airway resistance
  - 4 settings
- Simulated spontaneous breathing
- Bilateral and unilateral chest rise and fall

- CO2 exhalation
- Normal and abnormal breath sounds
  - 5 anterior auscultation sites
  - 6 posterior auscultation sites
- Oxygen saturation and waveform
- Extensive ECG library
- Heart sounds - four anterior locations
- ECG rhythm monitoring (4 wire)
- 12 lead ECG display
- Defibrillation and cardioversion
- Pacing

**Conclusions/action items:**

This simulator has a lot of complex features associated with it, acting basically a human simulator, but with all these features its very expensive and only useful for for classes teaching about all of the human function, rather than one specific subsection. Our, simulator will not have all of these features and will mostly be focused on the breathing and heart rate capabilities. Also, we plan to make our simulator wearable rather than one that is a mannequin and life like, so its easy to move around and does not require proper conditions like the one above is used in. Also, the design above brought up valid points like having a rechargeable battery setting, so that the simulator can be used wirelessly, we can use a capacitor within our circuit to make this happen. In addition, we will need leads to display ECG signals, either we can fabricate signals to display, or if we want to develop a band pass or band stop filter, we can take up frequencies of a certain AC signal and display those as well. Overall, this project can go in two directions, either fabricate data and have that be displayed for more accuracy, or to have data that matches real life situations and have it be more practical.

SimMan® 3G. (n.d.). Retrieved October 06, 2020, from <https://www.laerdal.com/us/doc/85/SimMan-3G>



## 09/23/20 Fidelity Simulator Requirements

---

RUSHABH TOLIA - Sep 23, 2020, 7:26 PM CDT

**Title:** Fidelity Simulator Requirements

**Date:** 09/23/20

**Content by:** Rushabh Tolia

**Goals:** To understand what the fidelity with respect to simulators mean and what is the objective of the simulator.

**Content:**

- the degree to which a particular manikin can reproduce or mimic human physiology is known as fidelity
- . The 2.5 billion dollars generated worldwide by the companies that manufacture and develop human simulators speaks to the spread of their use around the globe.
- The level of fidelity identifies the degree to which the manikins can replicate various human physiological functions. Low fidelity manikins or task trainers are simple, static models which are often used for repetitive task training such as inserting urinary catheters or starting IVs
- Basic cardiopulmonary resuscitation manikins are used extensively to train professionals and public how to perform chest compressions and rescue breathing (CPR training)
- Mid-fidelity manikins are more complex. Many contain electrical components that mimic basic body functions such as cardiac and respiratory function
- Simple simulations where the learner needs practice assessing vital signs or they can be used in simple scenarios where interpretation of complex physiological functions is not required
- First assess the manikin and then make an independent decision about whether it is safe for them to give or hold a medication. These decisions build clinical competence and expertise
- At the highest end of the scale, whole body manikins, like the SimMan3D, can simulate (mimic) multiple complex body systems
- During a scenario the manikin's anatomy can be modified (from the control room) to show changes in the patient's condition or responses to an intervention
- This is an interactive simulator created in collaboration with the American Academy of Pediatrics to meet the training requirements of the Neonatal Resuscitation Program (NRP)
- Mid-level fidelity simulators are designed to perform many of the same functions as their high-fidelity counterparts, but are simpler and therefore require less training to operate. Being less complex, these manikins often come at a lesser price
- One type of mid-level fidelity Human Patient Simulator is the VitalSim, including Anne, Kelly and Kid. These Laerdal manikins, which simulate ECGs, heart sounds, breath sounds, bowel sounds, blood pressure and pulse
- This manikin is additionally programmed with 30 cardiac conditions and more than 200 different bedside findings.
- Touch-Sensitive technology provides objective and measurable feedback to learners and instructors alike.



- The image above shows the training that occurs with the mannequin and how it occurs

#### Conclusions/action items:

In the text above it talks about how fidelity for simulators work and that low fidelity simulators are ones that work with CPR and IV systems and are not complex, mid fidelity will work with breathing and cardiac scenarios limited complexity, and high fidelity works with mannequin models that allow direct communication and more advanced methods of patient analysis. For our project, the fidelity of the project will be mid level because we are not looking for the high complexities or low complexities, this can be used as a category for our design matrix as some of our designs will have more advanced fidelity systems than other ones. In addition, now we can begin research on how we can get the electrical components to work with our mid level fidelity system in a way that will optimally set up our design.

High Fidelity Simulation: Healthcare Simulation. (2019, March 21). Retrieved September 24, 2020, from <http://www.healthysimulation.com/high-fidelity-simulation/>



## 09/23/20 Design Ideas for Design Matrix

RUSHABH TOLIA - Sep 23, 2020, 7:48 PM CDT

**Title:** Design Ideas for Design Matrix

**Date:** 09/23/20

**Content by:** Rushabh Tolia

**Present:** N/A

**Goals:** Come up with potential designs for the electrical analysis part of the project for the design matrix that needed to be done.

**Content:**

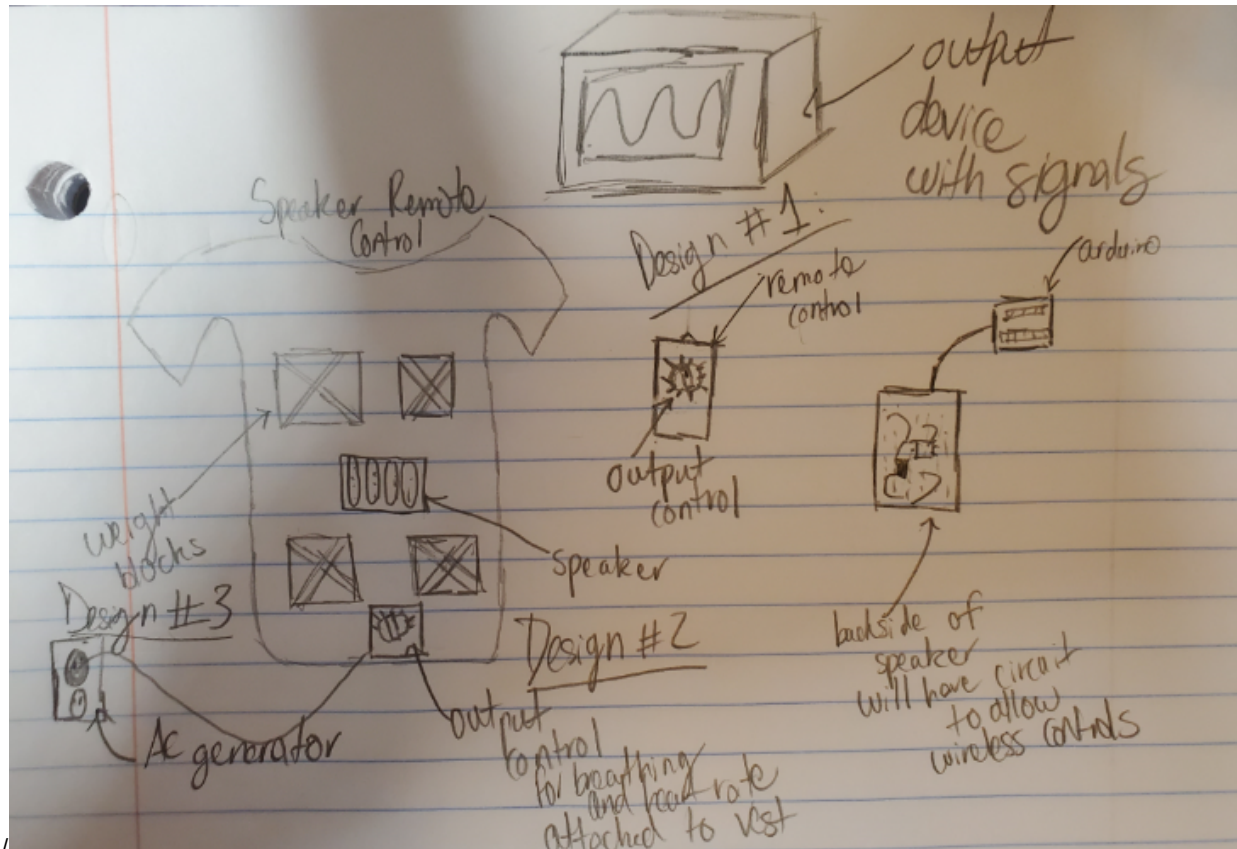

Design #1: Remote Control that can control output of the breathing and heart rates

Design #2: Output control that will be on the vest and will control breathing and heart rates

Design #3: The output will directly be sent to a screen that has a low pass/high pass circuit and will control the breathing and heart rate controls as an AC generator

**Conclusions/action items:**

From the design #1 the vest breathing and heart rate controls will be controlled remotely as it will be more optimal for the results needed by the client as the client has stated movement of the vest will be crucial and having an external device for controls will be optimal for them. The second design places the output control on the vest itself and will allow more easier wire action and will not be as complex as making a remote control that will change the breathing and heart rates in the vest itself, from the manufacturing point of view this design would be very optimal. Lastly, the third design will connect from a circuit to an ac outlet that will send signal information to an output device, like a laptop, that will allow for the most accurate results, as the signals will be connected via a high pass and low pass and a differential operational amplifier that will filter unnecessary signals out, however this design would fail in the motility aspect unless a voltage capacitor is used to store up the voltage necessary to power the device.



## 10/04/20 Circuitry Designs for Heart Functions

RUSHABH TOLIA - Oct 05, 2020, 10:11 PM CDT

**Title:** Circuitry used For Heart Signal Attenuation

**Date:** 10/05/20

**Content by:** Rushabh Tolia

**Present:** N/A

**Goals:** Understand possible circuits that can be used to develop an electrical signal that simulates a heart.

**Content:**

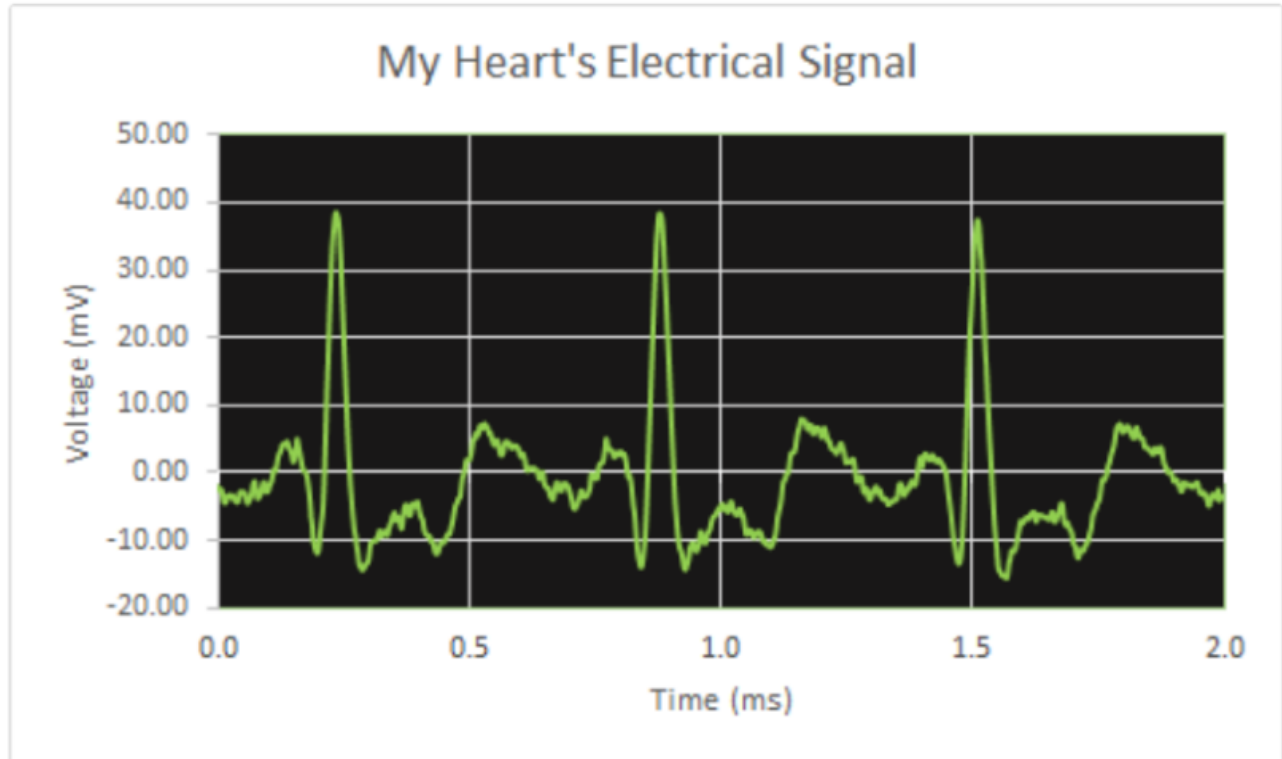

- 
- The above image shows an example of heart signal and the variables being measured are voltage over time
- measure heart rate using labVIEW software
- ECG is a useful diagnostic tool for medical professionals. It can be used to diagnose a multitude of heart conditions, from the basic heart attack (myocardial infarction), all the way to more advanced cardiac disorders, such as atrial fibrillation, that people may go a majority of their life without noticing
- electrical signals to the heart, which travel from the SA node to the AV node, and then to the left and right ventricles synchronously, and finally from the endocardium to the epicardium and purkinje fibers, the hearts last line of defense
- For Circuit Design:
  - Breadboard
  - OP Amps x 5
  - Resistors
  - Capacitors
  - Wires
  - Alligator Clips, or other methods of stimulating and measuring
  - BNC cables
  - Function Generator
  - Oscilloscope
  - DC Power Supply, or batteries if you're handy
- For Heart Rate Detection:
  - LabView
  - DAQ Board

- For Biological Signal Measurement\*
  - Electrodes
  - Alligator Clips, or electrode leads
- The instrumentation amplifier will be the first stage in the circuit. This versatile tool buffers signal, reduces common mode noise, and amplifies signals
- Need to *buffer* the signal we are interested in measuring
- use a difference amplifier to reduce common-mode noise
- Power lines in the U.S. produce a "mains hum" or "power line noise" at exactly 60 Hz. In other countries this occurs at 50 Hz.

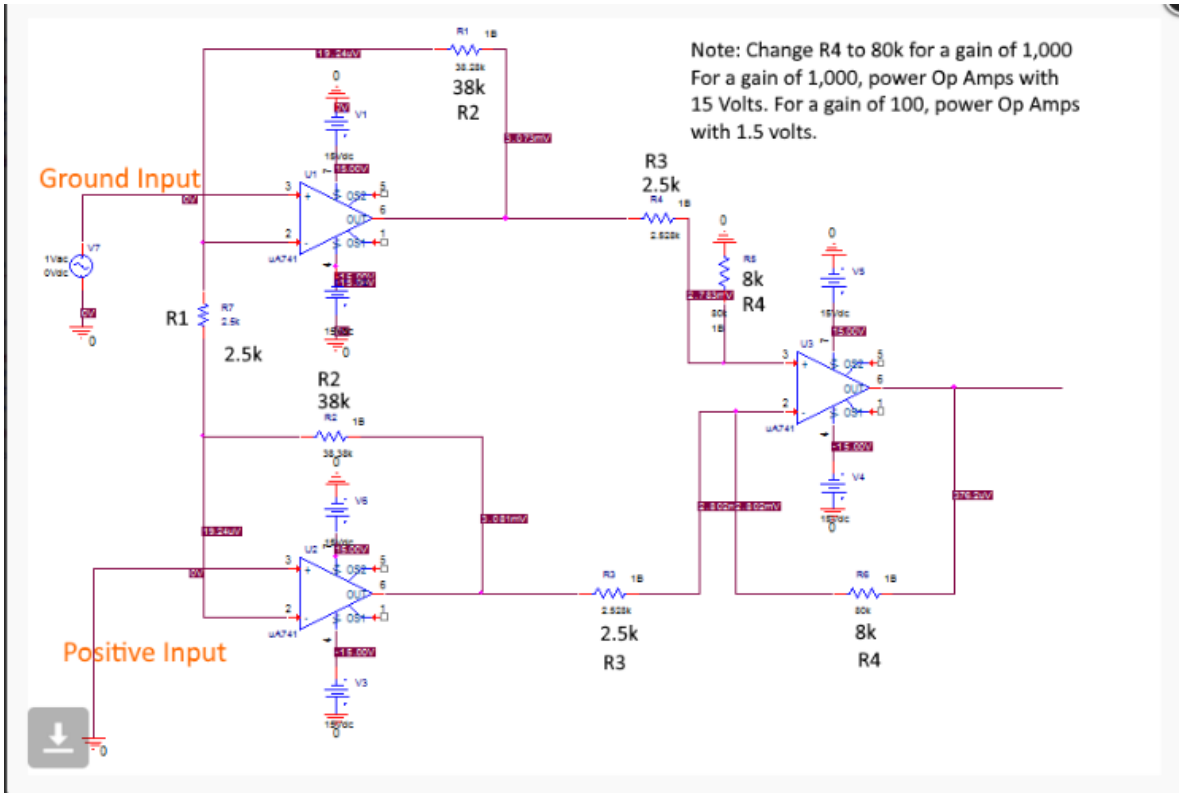

Stage 1 Gain:  $K_1 = 1 + \frac{2R_2}{R_1}$

Stage 2 Gain:  $K_2 = -\frac{R_4}{R_3}$

- The above circuit diagram shows the first step of constructing an instrumentation amplifier
- LabVIEW will allow us to measure heart-rate using a logic-block diagram. Given more time, I would have preferred to digitize the data myself and create code that would determine heart-rate, as it wouldn't require computers with labVIEW installed and a hefty DAQ board

#### Conclusions/action items:

The article focuses on how signals can be read from a human being, however our project is supposed to make "fake" heart signals, rather than develop actual ones from a human body. For this reason, the above circuits are not as practical, however the application LabVIEW can be very useful to test how signal output is coming for our speakers. Since, we are not using actual signals from a human body, it may be possible to produce diagrams that show heart signals that have different heart issues, as it's more practical to get that application to work, rather than to build a fully functioning circuit that will measure heart signal from a human being, as there may be an issue with short circuits affecting a person. This circuit could be possible in the future if the client wants the vest to be warn and take heart EKG signals.





## 10/07/2020 Circuitry for Lung and Heart Sounds

RUSHABH TOLIA - Oct 07, 2020, 1:44 PM CDT

**Title:** Circuitry for Lung and Heart Sounds

**Date:** 10/07/20

**Content by:** Rushabh Tolia

**Present:** N/A

**Goals:** To understand the mechanisms to develop a circuit that can output breathing and heart beating sounds.

**Content:**

- For heart sounds measurement must operate the frequency response between 20 – 800 Hz, and lung sounds measurement must operate the frequency response between 160 – 4,000 Hz
- designed PZT piezoelectric ceramics for both frequency response in the same PZT sensor
- converts a signal from aural vital sign form to voltage signal
- suitably amplified and re-filtered in band pass frequency band
- converted to digital signal by an analog to digital conversion circuitry developed for the purpose
- results were that all signals can fed to personal computer through the sound card port
- data of each patient call dot pcg (.pcg) for drawing graph and dot wave (.wave) for sound listening or automatic sending via electronic mail to the physician for later analysis of interpreting the sounds on the basis of their time domain and frequency domain representation to diagnose heart disorders
- Although not everyone agrees as to what extent a stethoscope should be used, the aural vital signs sounds (such as heart and lung sounds) radiated by diseased heart and lungs are regarded by most clinicians as information of important diagnostic value
- measure aural vital signs sound (second 2). In section 3 we describe the fundamental interpretation of aural vital signs are consist heart and lung sounds

**Table 1.**

Compare with heart and lung sounds.

	Sound	Frequency (Hz)
<b>Heart</b>	Low pitched heart murmurs	400
	High pitched heart murmurs	660
	Systolic and Diastolic	120-660
<b>murmurs</b>	Presystolic murmurs	140
	Pericardial rub	140-660
<b>Lungs</b>	Rales	120-1,000
	Amphonic breathing	240-660
	Bronchial	240-1,000

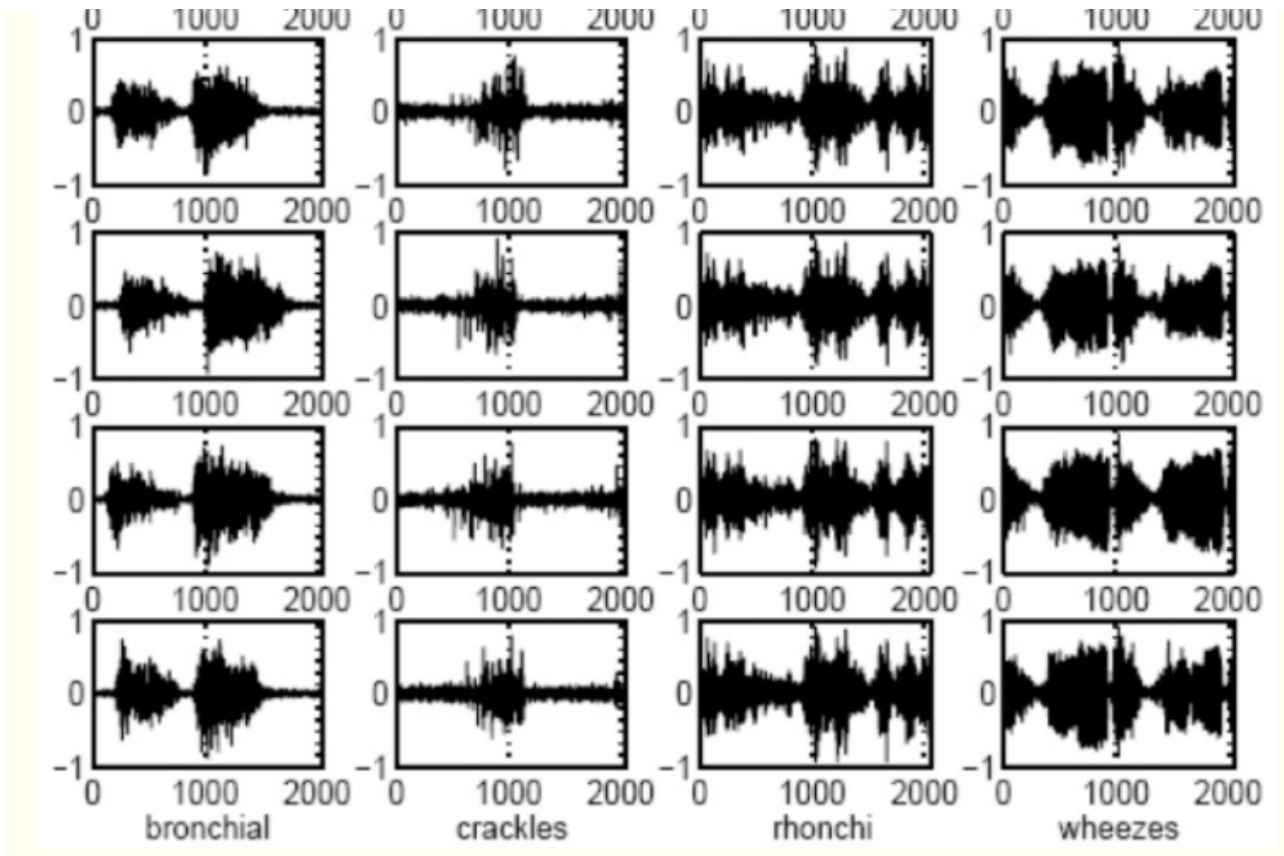

- Lung sounds shown above for indicating which signals mean different conditions



[Figure 14.](#)

Prototype of aural vital signs system.

#### Conclusions/action items:

The article went into depth on how to take in signals of patients heart sounds and breathing sounds and what frequencies and wavelengths each signal meant for the condition the patient was currently in. Though this article was very descriptive, it is not ideal for the team because we are not accessing actual patient sounds, but rather generating fake signals that simulate the patient breathing/heart sounds and signals. For this reason,

we can use the sounds that have previously generated from patients before and use those specific sounds and signals for the purposes of teaching healthcare professionals what specific signals and sounds mean.

Noimanee, S., Tunkasiri, T., Siriwitayakorn, K., & Tantrakoon, J. (2007, November 11). Design Considerations for Aural Vital Signs Using PZT Piezoelectric Ceramics Sensor Based on the Computerization Method. Retrieved October 07, 2020, from <https://www.ncbi.nlm.nih.gov/pmc/articles/PMC3841890/>



## 2020/12/08- Arudino Uno Soundboard Multiple Design

RUSHABH TOLIA - Dec 08, 2020, 6:18 PM CST

**Title:** Raspberry Pi Zero Sound Board

**Date:** 12/08/20

**Content by:** Rushabh Tolia

**Present:** N/a

**Goals:** To look into different potential soundboard designs that can adequately match what the client is looking for when it comes to sound outputs.

**Content:**

- Devon's build uses a 12v 10 amp power supply controlled via a DC/DC converter. This supply powers the Raspberry Pi 3B+ and four \$15 audio amplifiers, which in turn control simple non-powered speakers designed for use in laptops. As the sound is only required in mono, the four amplifiers can provide two audio tracks each, each track using a channel usually reserved for left or right audio output.



- The code is based on the sound device library for python, whose documentation is pretty sparse. This script will find the audio files, and then play them on as many devices as there are attached. For example, if you have 3 sound devices it will play 1.wav, 2.wav and 3.wav on devices 1-3. If you have any questions, feel free to ask
- It is worth it to give a simple example of how to play multiple files on multiple audio devices using python. I couldn't find an examples on how to do this online and had to spend some time experimenting to make it all come together



- The following illustrates the different components of the circuitry involved

**Conclusions/action items:**

In conclusion, the design we found was very interesting in the fact that multiple outputs could come out of one board and each one has one has their own individual sound associated with that specific usb device that holds the wav file. However, the issue with this design is that for us we need to change the output sounds to different sounds, so at one point you can hear normal heart rates and at another point you can hear a faster heart rate sound. For this reason, the design would not work unless we switch usb devices every time a change in heart sound is made which would require the user to change the usb device manually and be unnaturally difficult. From this design, we found that the arduino uno that was used would work well as it would allow users to use it from outside the device.

<https://www.raspberrypi.org/blog/multiple-sounds-simultaneously-raspberry-pi/>



## 2020/12/08- Arduino Uno

RUSHABH TOLIA - Dec 08, 2020, 8:16 PM CST

**Title:** Arduino Uno/ Arduino Zero

**Date:** 12/8/20

**Content by:** Rushabh

**Present:** N/A

**Goals:** To understand how arduino uno/zero works and see how it can be integrated into the wireless feature of the project.

**Content:**

### Arudino Uno

- It has 14 digital input/output pins (of which 6 can be used as PWM outputs), 6 analog inputs, a 16 MHz ceramic resonator (CSTCE16M0V53-R0), a USB connection, a power jack, an ICSP header and a reset button. It contains everything needed to support the microcontroller; simply connect it to a computer with a USB cable or power it with a AC-to-DC adapter or battery to get started

Microcontroller	ATmega328P
Operating Voltage	5V
Input Voltage (recommended)	7-12V
Input Voltage (limit)	6-20V
Digital I/O Pins	14 (of which 6 provide PWM output)
PWM Digital I/O Pins	6
Analog Input Pins	6
DC Current per I/O Pin	20 mA
DC Current for 3.3V Pin	50 mA
Flash Memory	32 KB (ATmega328P) of which 0.5 KB used by bootloader
SRAM	2 KB (ATmega328P)
EEPROM	1 KB (ATmega328P)
Clock Speed	16 MHz
LED_BUILTIN	13
Length	68.6 mm
Width	53.4 mm
Weight	25 g

- The module can use 125 different channels which gives a possibility to have a network of 125 independently working modems in one place. Each channel can have up to 6 addresses, or each unit can communicate with up to 6 other units at the same time
- The power consumption of this module is just around 12mA during transmission, which is even lower than a single LED. The operating voltage of the module is from 1.9 to 3.6V, but the good thing is that the other pins tolerate 5V logic, so we can easily connect it to an Arduino without using any logic level converters.
- Three of these pins are for the SPI communication and they need to be connected to the SPI pins of the Arduino, but note that each Arduino board has different SPI pins. The pins CSN and CE can be connected to any digital pin of the Arduino board and they are used for setting the module in standby or active mode, as well as for switching between transmit or command mode. The last pin is an interrupt pin which doesn't have to be used

- It's worth noting that **power supply noise** is one of the most common issues people experience when trying to make successful communication with the NRF24L01 modules. Generally, RF circuits or radio frequency signals are sensitive to power supply noise. Therefore, it's always a good idea to include a decoupling capacitor across the power supply line. The capacitor can be anything from 10uF to 100uF

### Arduino Zero

- The Zero is a simple and powerful 32-bit extension of the platform established by the UNO. The Zero board expands the family by providing increased performance, enabling a variety of project opportunities for devices, and acts as a great educational tool for learning about 32-bit application development
- The board is powered by Atmel's SAMD21 MCU, which features a 32-bit ARM Cortex® M0+ core. One of its most important features is Atmel's Embedded Debugger (EDBG), which provides a full debug interface without the need for additional hardware, significantly increasing the ease-of-use for software debugging

Microcontroller	ATSAMD21G18, 32-Bit ARM Cortex M0+
Operating Voltage	3.3V
Digital I/O Pins	20
PWM Pins	All but pins 2 and 7
UART	2 (Native and Programming)
Analog Input Pins	6, 12-bit ADC channels
Analog Output Pins	1, 10-bit DAC
External Interrupts	All pins except pin 4
DC Current per I/O Pin	7 mA
Flash Memory	256 KB
SRAM	32 KB
EEPROM	None. See documentation
LED_BUILTIN	13
Clock Speed	48 MHz
Length	68 mm
Width	53 mm
Weight	12 gr.

- VIN. The input voltage to the board when it's using an external power source (as opposed to 5 volts from the USB connection or other regulated power source). You can supply voltage through this pin, or if supplying voltage via the power jack, access it through this pin

The Zero has a 32-bit ARM core that can outperform typical 8-bit microcontroller boards. The most significant differences are:

- 32-bit core that allows operations on 4 byte wide data within a single CPU clock. (For more information see the [int type](#) page)
- CPU Clock at 48MHz

12 channels DMA controller that can relieve the CPU from doing memory intensive tasks  
32 bit Real Time Counter (RTC) with clock/calendar function  
32 bit CRC generator  
Two-channel Inter IC Sound (I2S) interface  
Peripheral Touch Controller (PTC)

**Conclusions/action items:**

In conclusion, the arduino uno can be used to test the device and make sure the right sounds are being outputted from the adafruit soundboard, similarly the arduino zero can be used to have inputs be put in from a mobile device and have the output sounds be changed. Luckily for us, all BME students have access to an arduino uno, so the testing project will be easily done with the resources we currently have. However, the arduino zero will need to be bought, and more programming will be needed to get the system to work as expected. In addition, the arduino programming involved will be very minimal and be easily accessible.

<https://store.arduino.cc/usa/arduino-uno-rev3>

<https://howtomechatronics.com/tutorials/arduino/arduino-wireless-communication-nrf24l01-tutorial/>

<https://store.arduino.cc/usa/arduino-zero>





# 11/30/20 Circuit Adafruit design

RUSHABH TOLIA - Nov 30, 2020, 12:40 AM CST

**Title:** Circuit Adafruit Design Diagram

**Date:** 11/30/20

**Content by:** Rushabh

**Present:** N/a

**Goals:** Develop a circuit diagram that properly illustrates how to design the speaker adafruit design.

**Content:**

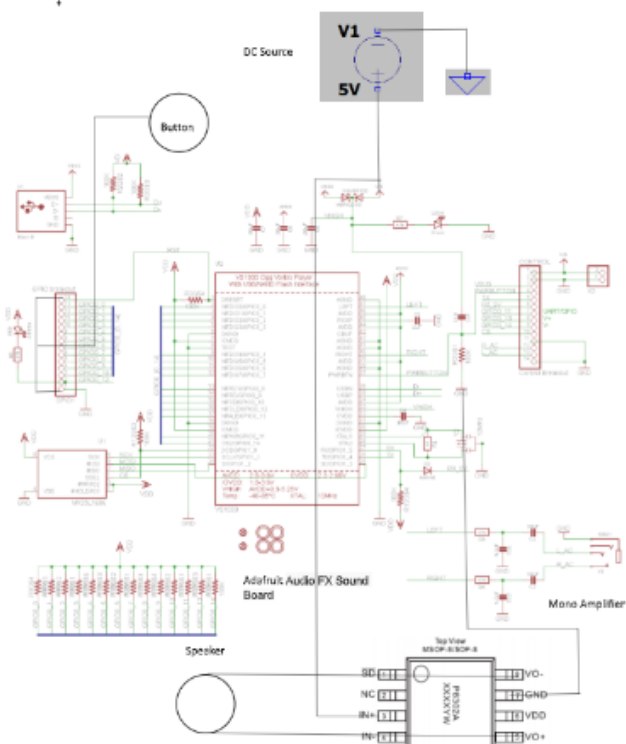

**Conclusions/action items:**

I developed a circuit diagram that clearly illustrates how to put all the input and output terminals in order. The point of this design is to help our group come together and make the design fully functioning for the project deadline. From this circuit design, I hope to add a few other parts that may be integral in the future, for instance an arduino uno that can change the outputs of the heart rates in the simulator.



# 11/30/20 Adafruit Speaker Details

RUSHABH TOLIA - Nov 30, 2020, 1:29 AM CST

**Title:** Adafruit Speaker Design Details

**Date:** 11/30/20

**Content by:** Rushabh Tolia

**Present:** N/A

**Goals:** To understand how the adafruit speaker setup and operational amplifiers will work together to reach the final product design.

**Content:**

- No Arduino or other microcontroller required! It is completely stand-alone, just needs a 3 to 5.5VDC battery
  - Small - only 1.5" x 0.9"
  - Built in storage - yep! you don't even need an SD card, there's 2MB of storage on the board itself. Good for a few minutes of compressed stereo, and maybe half a minute of uncompressed stereo. Double that if you go with mono instead of stereo. [If you need more space we have a 16MB version here](#)
  - Built in Mass Storage USB - Plug any micro USB cable into the Sound Board and your Windows computer, you can drag and drop your files right on as if it were a USB key
  - Compressed or Uncompressed audio - Go with compressed Ogg Vorbis files for longer audio files, or uncompressed WAV files
  - High Quality Sound - You want 44.1KHz 16 bit stereo? Not a problem! The decoding hardware can handle any bit/sample rate and mono or stereo
  - 8 Triggers - Connect up to 8 buttons or switches, each one can trigger audio files to play
  - Stereo line out - Right and Left, AC-coupled audio out. Use headphones, powered speakers or even wire up one of our amplifiers to make loud sounds. [We also have a version with built-in stereo speaker amplifier](#)
  - Five different trigger effects - by changing the name of the files, you can create five different types of triggers which will cover a large range of projects *without* any programming
  - Control over UART (9600 Baud) via any microcontroller, we have an Arduino Library for basic control over playback and volume.
- What do we mean by trigger effects? Well, depending on your project you may need to have audio play in different ways. We thought of the five most common needs and built it into the Sound Board so you just rename the file to get the effect you want. [See the product tutorial for more details](#)
    1. Basic Trigger - name the file Tnn.WAV or Tnn.OGG to have the audio file play when the matching trigger pin nn is connected to ground momentarily
    2. Hold Looping Trigger - name the file TnnHOLDL.WAV or .OGG to have the audio play only when the trigger pin is held low, it will loop until the pin is released
    3. Latching Loop Trigger - name the file TnnLATCH.WAV or .OGG to have the audio start playing when the button is pressed momentarily, and repeats until the button is pressed again
    4. Play Next Trigger - have up to 10 files play one after the other by naming them TnnNEXT0.WAV thru TnnNEXT9.OGG. Will start with #0 and each one on every momentary button press until it gets through all of them, then go back to #0
    5. Play Random Trigger - just like the Play Next trigger, but will play up to 10 files in random order (TnnRAND0.OGG thru TnnRAND9.OGG) every time the button is pressed momentarily

The sound board is designed to be simple: it does not have polyphonic ability, can't play MP3's (MP3 is patented and costs \$ to license, so this board uses the similar but not-patented OGG format, there's tons of free converters that will turn an MP3 into OGG), isn't reprogrammable or scriptable, and you can't have any other kind of trigger type. However, there's a good chance the project you want to make will work great.

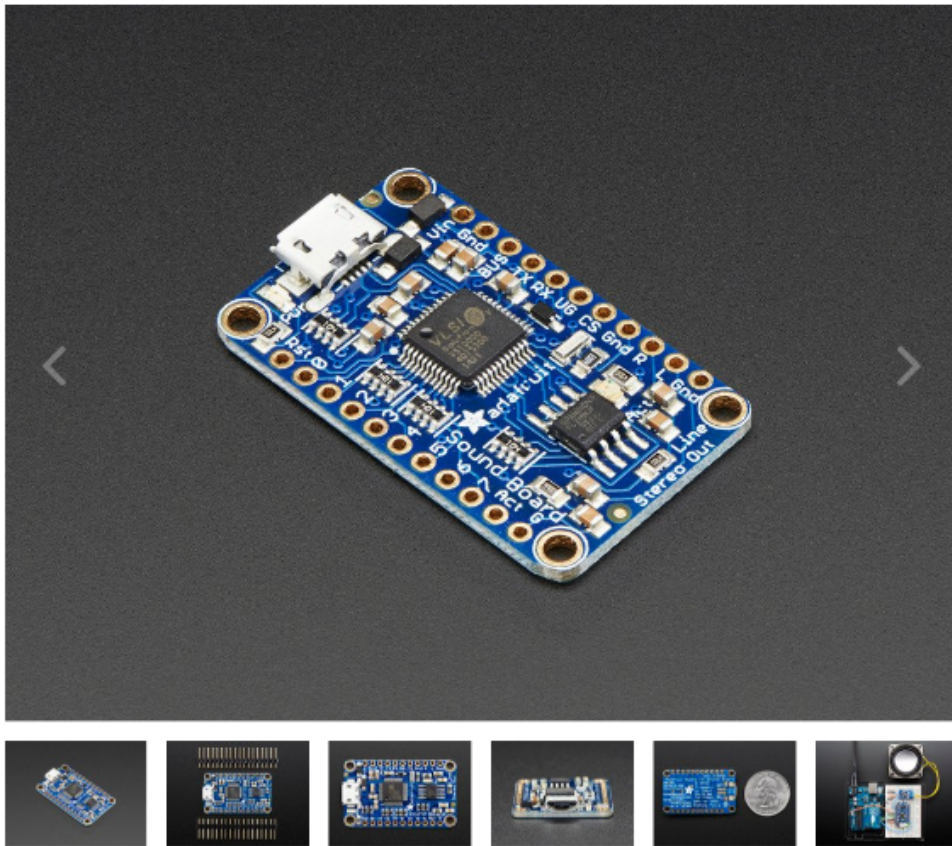

This super small mono amplifier is surprisingly powerful - able to deliver up to 2.5 Watts into 4-8 ohm impedance speakers. Inside the miniature chip is a class D controller, able to run from 2.0V-5.5VDC. Since the amp is a class D, its very efficient (over 90% efficient when driving an 8Ω speaker at over half a Watt) - making it perfect for portable and battery-powered projects. It has built in thermal and over-current protection but we could barely tell it got hot. There's even a volume trim pot so you can adjust the volume on the board down from the default 24dB gain. This board is a welcome upgrade to basic "LM386" amps!

The A+ and A- inputs of the amplifier go through 1.0uF capacitors, so they are fully 'differential' - if you don't have differential outputs, simply tie the Audio- pin to ground. The output is "Bridge Tied" - that means the output pins connect directly to the speaker pins, no connection to ground. The output is a high frequency 250KHz square wave PWM that is then 'averaged out' by the speaker coil - the high frequencies are not heard. All the above means that you can't connect the output into another amplifier, it should drive the speakers directly.

Comes with a fully assembled and tested breakout board. We also include header to plug it into a breadboard and a 3.5mm screw-terminal blocks so you can easily attach/detach your speaker. You will be ready to rock in 15 minutes! Speaker is not included, use any 4 ohm or greater impedance speaker.

Output Power: 2.5W at 4Ω, 10% THD, 1.5W at 8Ω, 10% THD, with 5.5V Supply 50dB PSRR at 1KHz  
 Filterless design, with ferrite bead + capacitors on output. Fixed 24dB gain, onboard trim potentiometer for adjusting input volume. Thermal and short-circuit/over-current protection Low current draw: 4mA quiescent and 0.5mA in shutdown (due to pullup resistor on SD pin)

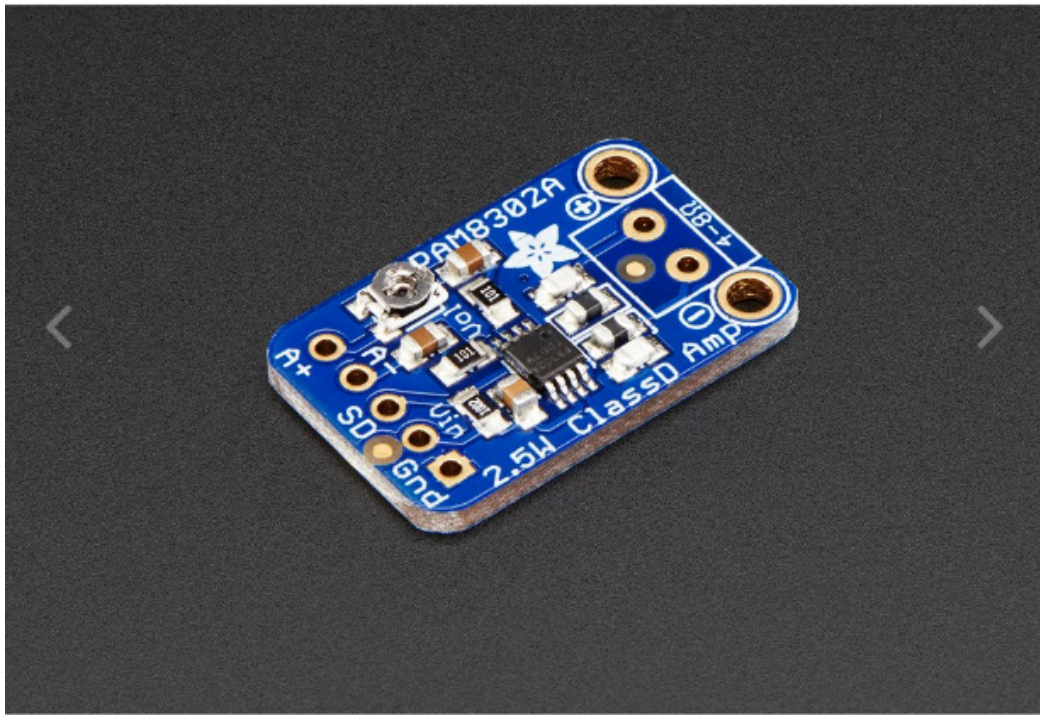
**Conclusions/action items:**

The adafruit design setup was given to us by Dr. Nimunkar and as a team we decided this speaker layout would work very well for the expected design. The reason for this was because the other soundboards are more expensive and are more complex when it comes to have multiple outputs per speaker, while this adafruit design has set number outputs, but has the necessary number that client needs to relay all the outputs needed. The idea is to have three adafruit speakers and three relays one for the heart and two for the lung sounds. The total cost of materials will be very minimal, and we plan to start off with a cheaper speaker and see how the output compares to one that is more expensive and can later choose for the higher end model if the need arises. The next step is to ask the client to purchase the materials and make the circuitry to have the relay be present.



RUSHABH TOLIA - Mar 05, 2020, 2:15 AM CST



20200305\_012945.jpg(926 KB) - [download](#)



## Meeting #1

---

CAROLINE GERVOLINO - Sep 09, 2020, 7:56 PM CDT

**Title:** Meeting #1 9/4/2020 (Friday)

**Date:** 9/4/2020 (Friday)

**Content by:** Caroline Gervolino

**Present:** Elijah McCoy, Tim Tran, Emma Nuemann, Gabrielle Snyder, Rushabh Tolia

**Goals:** To meet each other and discuss our plans for our project

**Content:**

On microsoft teams, we introduced ourselves. We set up a time to meet with our project advisor, which is most likely Friday during the normal classtime slot. Some student will be meeting in person and some will have to meet virtually.

**Conclusions/action items:** We will reconvene with new research, ideas, prepare for our client meeting and work on our progress report 1.



## Meeting #2

---

CAROLINE GERVOLINO - Sep 09, 2020, 8:37 PM CDT

**Title:** Meeting #2 9/9/20 (Wednesday)

**Date:** 9/9/20

**Present:** Elijah McCoy, Tim Tran, Emma Nuemann, Gabrielle Snyder, Rushabh Tolia

**Content by:** Caroline Gervolino

**Content:**

We have meeting with our advisor at 1pm on Friday, probably not in-person, have to send a follow up email. Talked about contact meeting, doing more research and adding to progress report 1.

**Conclusions/action items:** Update PDS, after advisor meeting on Friday. Assign roles in the PDS



## 9/9/20 Research of Medical Mannequins for Education

---

CAROLINE GERVOLINO - Sep 09, 2020, 7:49 PM CDT

**Title:** Research of Medical Mannequins for Education

**Date:** 9/9/2020

**Content by:** Caroline Gervolino

**Present:** N/A

**Goals:** To understand the current technology used in medicine education and identify what useful parts of this invention we can use.

**Content:**

A Medical Mannequin is a patient simulator that is suppose to be life-like and mimic real patient scenarios. The goal of these mannequins is to have student bring their knowledge outside the classroom, and get "real experiences" so that they are better prepared for these situations as they arise in the field.

Advanced mannequins are capable of breathing, producing life-like sounds and heart tones and a palpable pulses. They can also connect to a EKG monitor, pulse oximeter, arterial waveforms, pulmonary artery waveforms, and anesthetic gases monitor.

The mannequins are linked to a computer and they have the technology to give back feedback and react to situations. The goal is to have students develop "muscle memory" when performing procedures, and allow for errors to be noticed and fixed before interacting with real patients. There are many different designs with different specialties and functions in mind.

Each medical professional setting comes with different demands, simulation tailor to each kind of position for more comprehensive learning.

For example, to simulate nursing and emergency concepts mannequins include patient positioning and transfer techniques, intramuscular injection sites, bathing techniques, blood pressure training, urinary catheterization, NG tube placement, injection and more. As well as, airway during CPR, check blood pressure, carotid pulse and auscultate them.

On the other hand clinically-focused Medical mannequins focus more on actions such as bathing, transferring and skin inspection. In general, they will relay the basic clinical skills, cognitive thinking and behavioral communication needed to examine patients in a professional healthcare setting.

This technology is a hands on approach, to prepare for everyday patients in real time.

Reference: <https://www.healthysimulation.com/medical-manikin/>

**Conclusions/action items:** These medical mannequins and simulators are used to make for a real life situation for students. There are many different types of mannequins for different parts of the medical world. I will meet with my group to discuss more about our ideas, and questions for our client.





## 9/7/20 Basic Outline of the Project

---

CAROLINE GERVOLINO - Sep 09, 2020, 7:32 PM CDT

**Title:** Basic Outline of the Project

**Date:** 9/7/2020

**Content by:** Caroline Gervolino

**Present:** N/A

**Goals:** To deepen my understanding of the project, and begin basic research to help me form ideas for designs

**Content:**

Objective: to develop a vest that can be worn to aid medical students and education medicine in a more real and beneficial way

Project Description: to use the technology already used in mannequins/ sims to create a vest that an actual human wear, so make the experience more real. The person will be able to interact while a second person can control the vest, through wireless technology. The vest will make human noises and have a pulse.

"References" : <https://bmedesign.engr.wisc.edu/selection/projects/bb3bbfa9-9dee-42f9-97f8-46e7d19a7421>

**Conclusions/action items:**

This project is meant to enhance the learning project for student, where the actor and the person controlling the vest are educators there to help the students. The current issue is that, the technology makes it hard for students to feel like they are actually performing on a patient. This way medical professionals can be more prepared for real life work. My goal this week is to do some of my own background research on the current mannequins/sims and start brainstorming designs with my lab group.



# 9/17/20 Simple Simon Patient Care Manikin

EMMA NEUMANN - Dec 09, 2020, 6:13 PM CST

**Title:** 9/17/20 Simple Patient Care Manikin

**Date:** 9/17/20

**Content by:** Caroline Gervolino

**Present:** Caroline Gevolino

**Goals:** To do research and understand some designs and technology already implemented in medical mannequins.

**Content:**

Full-size adult manikin with movable joints as well as soft fingers and toes for training of important basic nursing skills such as:

- Surgical draping
- Bathing and bandaging
- Oral and denture hygiene (movable jaw with removable dentures)
- Ophthalmic exercises
- Ear irrigation and application of otic drops
- I.M. injection (arm and buttock)

Weight	31.97 lb
Brand	Gaumard Scientific Co. Inc.

Item No.	Susie Simon® Nursing Care Simulator	Susie Simon® Nursing Care Simulator	Simple Simon® Nursing Care Simulator	Simple Simon® Nursing Care Simulator	3B Scientifici c® Patient Care Manikin PRO
	without ostomy: 1017535 male and female	with ostomy: 1005785 male and female	without ostomy: 1005803 female	without ostomy: 1005807 male	1018816 male and female
Wig for hair care	✓	✓	✓	-	✓
Movable jaw with tongue	✓	✓	✓	✓	✓
Removable dentures	✓	✓	✓	✓	✓
Ear irrigation	✓	✓	✓	✓	✓
Nasogastric lavage and gavage	✓	✓	-	-	✓
Tracheotomy care	-	-	-	✓	✓
IM sites at upper arm and in buttock	✓	✓	✓	✓	✓
IM site at the uper legs	-	-	-	-	✓
Enema administration	✓	✓	-	-	✓
Catheterization	✓	✓	-	-	✓
Realistic vagina and cervix	✓	✓	✓	-	-
Vaginal douching and pap smear	✓	✓	-	-	-
Sculpted stomas	-	✓	✓	-	✓
Surgical & amputation wound	-	-	-	-	✓
Diabetic foot & decubitus ulcers	-	-	-	-	✓
Laceration wound	-	-	-	-	✓
Detachable and removable internal tanks	✓	✓	-	✓	✓
Transverse colostomy, ileostomy, and suprapubic stoma	-	✓	-	-	only colostomy

[www.3bscientific.co.uk/susie-simon-patient-care-simulator-without-ostomy-1017535-w45010-s200m,p\\_153\\_5233.html](http://www.3bscientific.co.uk/susie-simon-patient-care-simulator-without-ostomy-1017535-w45010-s200m,p_153_5233.html)

[www.3bscientific.co.uk/susie-simon-patient-care-manikin-with-ostomy-1005785-w45011-s201m,p\\_153\\_5234.html](http://www.3bscientific.co.uk/susie-simon-patient-care-manikin-with-ostomy-1005785-w45011-s201m,p_153_5234.html)

[www.3bscientific.co.uk/simple-susie-patient-care-simulator-female-1005803-w45057-s206m,p\\_153\\_5280.html](http://www.3bscientific.co.uk/simple-susie-patient-care-simulator-female-1005803-w45057-s206m,p_153_5280.html)

[www.3bscientific.co.uk/simple-simon-patient-care-manikin-medium-skin-1005807-w45070-gaumard-scientific-co-inc-s205m,p\\_153\\_5293.html](http://www.3bscientific.co.uk/simple-simon-patient-care-manikin-medium-skin-1005807-w45070-gaumard-scientific-co-inc-s205m,p_153_5293.html)

[www.3bscientific.co.uk/3b-scientific-patient-care-manikin-pro-1018816-p101-3b-scientific,p\\_153\\_27025.html](http://www.3bscientific.co.uk/3b-scientific-patient-care-manikin-pro-1018816-p101-3b-scientific,p_153_27025.html)

“Simple Simon Patient Care Manikin, Medium Skin.” *1005807 - W45070 - Gaumard Scientific Co. Inc. - S205.M - Adult Patient Care - 3B Scientific*, [www.a3bs.com/simple-simon-patient-care-manikin-medium-skin-1005807-w45070-gaumard-scientific-co-inc-s205m,p\\_153\\_5293.html?utm\\_source=google](http://www.a3bs.com/simple-simon-patient-care-manikin-medium-skin-1005807-w45070-gaumard-scientific-co-inc-s205m,p_153_5293.html?utm_source=google).

**Conclusions/action items:** Many of these different aesthetics features do not apply to our design because it is a vest and not an actual mannequin. So our group is more closely looking at the features that the mannequins can preforms. The most important ones we found were the pulse rate and heart sounds. We will attempt to figure out a way to implement these technological features into a vest with our designs



## 9/17/20 Simulaids SMART STAT Basic with iPad Research

CAROLINE GERVOLINO - Sep 17, 2020, 12:21 PM CDT

**Title:** 9/17/20 Simulaids SMART STAT Basic with iPad Research

**Date:** 9/17/20

**Content by:** Caroline Gervolino

**Present:** Caroline Gervolino

**Goals:** To understand the component of our design where a remote or in this case an Ipad is used by an external party to operate the machine.

**Content:**

This affordable patient simulator takes ALS training into the students' environment. Instructors can evaluate student knowledge, skill levels, and critical thinking abilities by utilizing the applications via the iPad®\*. This simulator can function in the lab and in the field for ascertaining diagnostic ability. Student performance records can be transferred to a computer, and chronological scenario event logs can be printed. SMART STAT Basic has an on-board air compressor, includes a free app on the iTunes Store®\* (SMART STAT), storage for students' performances, spontaneous breathing, pulses, blood pressure, carotid and femoral pulses, normal and emergent heart and lung sounds, 12 pulse points synchronized with the heart, EKG interpretation and cardiac treatment, IV catheterization and infusion, tension pneumothorax treatment, chest tube insertion with simulated drainage, and advanced difficult airway maintenance. Comes with an iPad®\*, USB cable, blood pressure cuff, hard carry case, shorts, and a supply of replacement parts.

### Advanced Airway Management

- STAT Deluxe Airway Management Head
- Tongue edema
- Laryngospasm
- Cricothyrotomy
- Breakout teeth
- Designed for LT, ET, LMA, and Combitube
- ECG
- 4-lead recognition of 17 rhythms
- Defibrillation and cardio conversion
- Variable rates
- Pacing

### Emergent Lung Sounds (anterior and posterior)

#### Emergent Heart Sounds

- BP Arm
- Independently vary systolic and diastolic pressures
- Korotkoff sound changes
- Vary the amplitude of the sound

#### Pulse Points

- 12 locations in pairs: carotid, femoral, popliteal, pedal (dorsal arch), radial, brachial (IV arm-antecubital, BP arm biceps pressure point)
- Distal pulses drop off under 70 mm Hg systolic
- Vary according to ECG rhythm

#### Bilateral Chest Decompression

- Right- or left-sided, partial or complete pneumothorax
- Audible air discharge upon proper catheterization, no repair necessary

#### Bilateral Chest Tube Insertion

- Auxiliary fluid bag allows for simulated discharge
- Practice maintenance

#### Virtual Capnography and Oximetry

#### Printable Chronological Student Session Reports & Scenarios

- Easy to establish
- Start up library includes samples
- Print out for convenience

#### Replacement Parts Included

- 10 neck skins
- 4 IM injection pads
- 6 pneumothorax pads
- 3 sets of teeth
- IV vein kit

\*iPad® and iTunes Store® are trademarks of Apple Inc., registered in the U.S. and other countries

“Simulaids SMART STAT Basic with iPad.” *Universal Medical*, [www.universalmedicalinc.com/simulaids-smart-stat-basic-with-ipad.html?campaignid=1049828359](http://www.universalmedicalinc.com/simulaids-smart-stat-basic-with-ipad.html?campaignid=1049828359).

**Conclusions/action items:** This type of design/ product is interesting because it uses an app on the i-pad instead of say having a remote that is linked to the device. This way the software could have the possibility of being updated and the same Ipad could be used among multiple mannequins or vests. In the future the group should consider using an app to operate the vest.



## 10/23/2020 Audio Libraries

EMMA NEUMANN - Dec 09, 2020, 6:26 PM CST

**Title:** Audio Libraries Research

**Date:** 10/23/2020

**Content by:** Caroline Gervolino

**Present:** Everyone

**Goals:** To get a deeper understanding of the possible sounds that will be implemented into the speaker, and to decide how accurate certain websites and the copyrights associated with each sound.

**Content:**

Although we may not be doing that extensive of sounds we should decide what the most basic and necessary sounds are. According to Littmann Library, sounds are split into six categories, aortic, Erb's point, mitral area, pulmonic area, tricuspid area, and lung sounds.

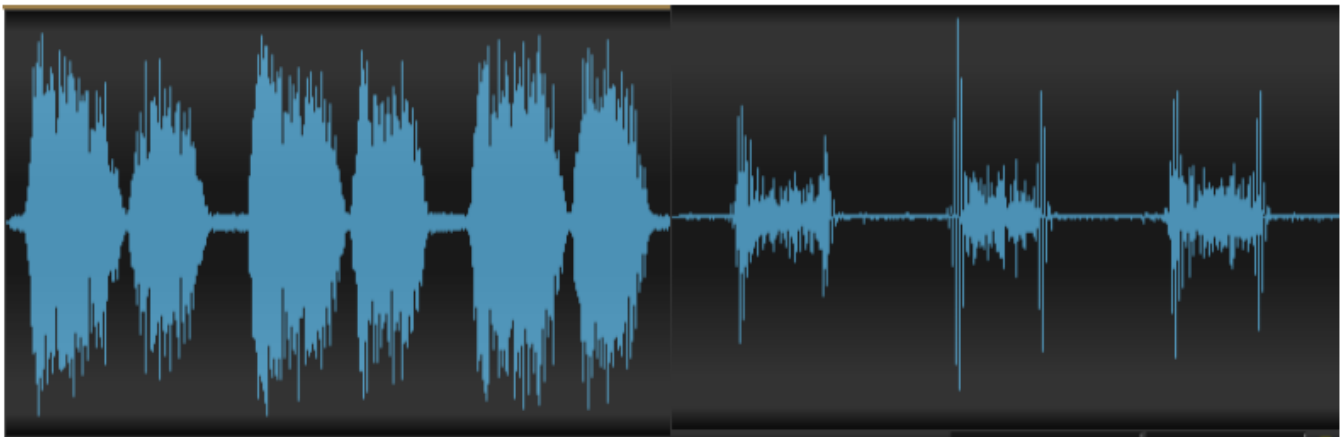

Bronchial

Murmur

**Bronchial:** [www.3m.com/healthcare/littmann/pn76.html](http://www.3m.com/healthcare/littmann/pn76.html)

**innocent Systolic Ejection Murmur - Standing:** [www.3m.com/healthcare/littmann/pn128.html](http://www.3m.com/healthcare/littmann/pn128.html)

**Conclusions/action items:**! Decide which sounds we want and how we can implement them.

<http://www.3m.com/healthcare/littmann/mmm-library.html>



# 9/23/20 Initial Design Idea

CAROLINE GERVOLINO - Sep 23, 2020, 5:04 PM CDT

**Title:** Initial Design Idea

**Date:** 9/23/20

**Content by:** Caroline Gervolino

**Goals:** to as a group come up with 3 preliminary designs and then vote on the best one

**Content:**

below

**Conclusions/action items:** meet with group on wednesday night go over designs

CAROLINE GERVOLINO - Sep 23, 2020, 5:07 PM CDT

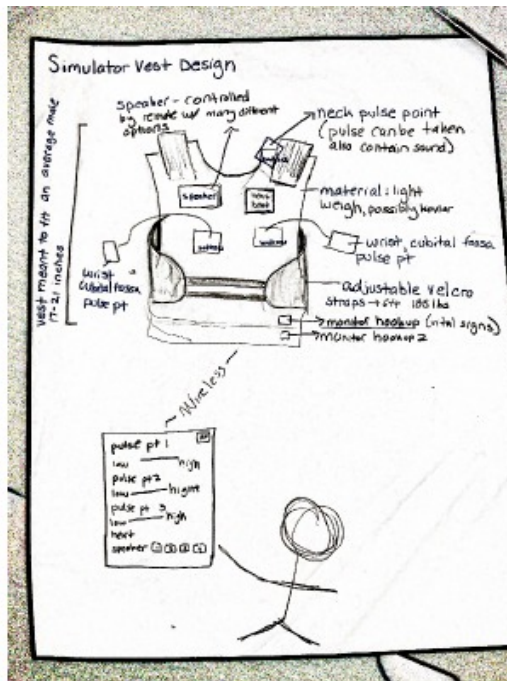

Doc\_09-23-2020\_17-00-49.pdf(896.6 KB) - download



## 10/6/20 Heart and Lung Sounds Reference Guide

---

ELIJAH MCCOY - Oct 06, 2020, 2:27 PM CDT

**Title:** Heart and Lung Sounds Reference Guide

**Date:** 10/06/2020

**Content by:** Elijah

**Present:** Elijah

**Goals:** To get heart and lung sounds examples

**Content:**

- On this website there are a lot of heart and lung sounds associated with lessons on how to determine what problems the patient may have based on the sounds
- These sounds could be played in the speakers to simulate these heart and lung sounds
- The sounds are a little hard to hear
- lots of different sounds from diseases that I am not sure of
  - may have to research more into these conditions

<https://www.practicalclinicalskills.com/heart-lung-sounds-reference-guide>

**Conclusions/action items:** These heart and lung sounds could be used in our design to be displayed through the speakers, or these sounds could serve as a reference for the sounds we may use in the future.





## 9/17/20 Research of S-Vest

ELIJAH MCCOY - Sep 17, 2020, 1:06 AM CDT

**Title:** Research of S-Vest

**Date:** 9/17/20

**Content by:** Elijah

**Present:** Elijah

**Goals:** To look for competing designs

**Content:**

Notes on S-Vest

- the S-Vest is a novel hybrid method to allow standardized patients to put on the objective physical examination findings of a disease
- this device is a vest with a set of speakers placed in an anatomical manner to produce sounds
  - sounds are played from a multitrack audio player with real sounds from a patient with real disease findings
- The vest is worn by a simulated patient to create a hybrid of real-life actors and speakers.



Here is an image of their simulator vest

**Conclusions/action items:** This vest is pretty similar to the vest we were thinking about creating. I think we could make ours different by focusing on the heart rate/pulse aspects of the vest.

<https://innovations.bmj.com/content/5/2-3/78.info>

Berg D, Berg K S-Vest: a novel hybrid method to allow standardised patients to put on the objective physical examination findings of a disease *BMJ Innovations* 2019;**5**:78-81.



## 9/22/20 Design Idea

---

ELIJAH MCCOY - Oct 06, 2020, 2:13 PM CDT

**Title:** Initial Design Idea

**Date:** 9/23/20

**Content by:** Elijah

**Present:** Elijah

**Goals:** To create initial designs

**Content:**

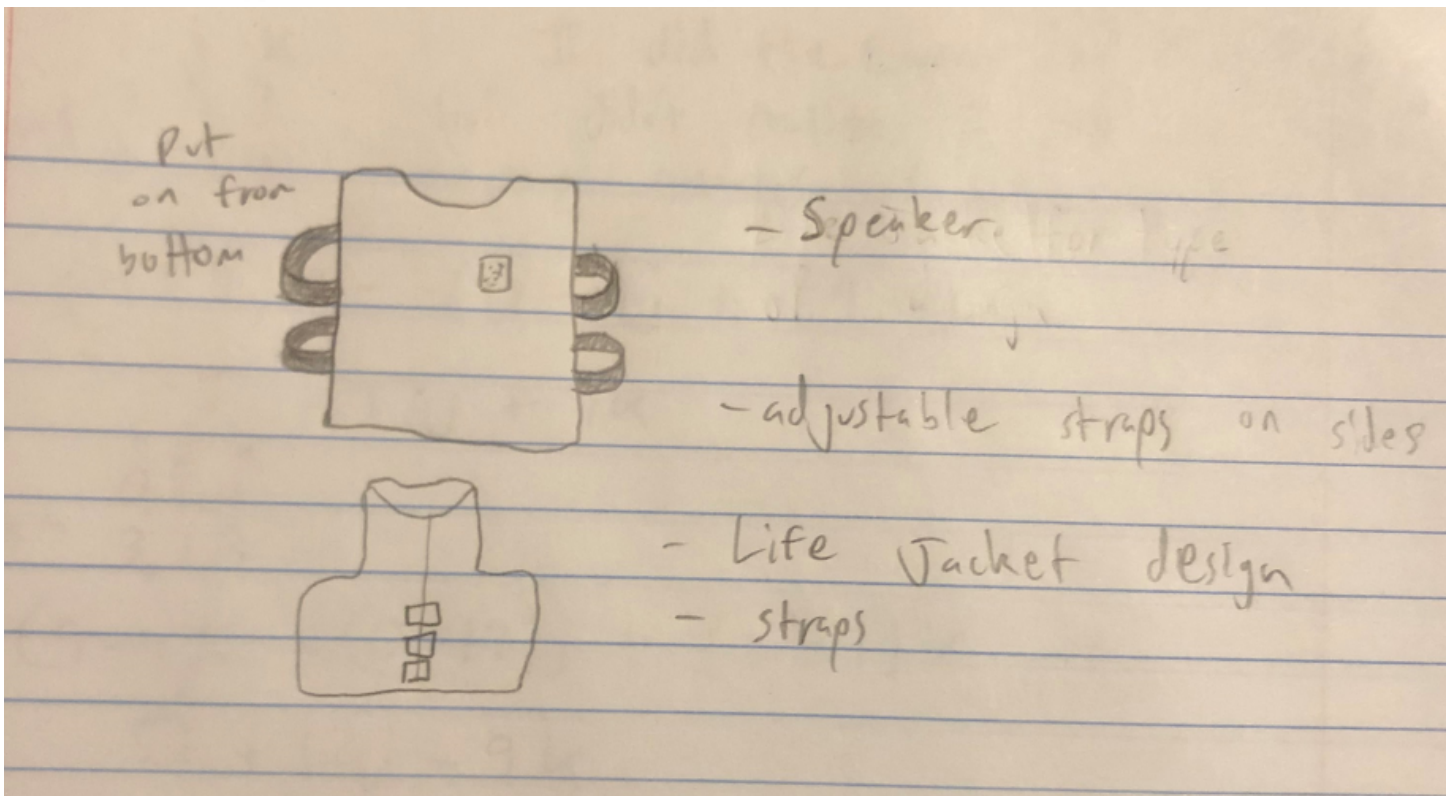

Life jacket design, adjustable, waterproof, thick for allowance of electronics to be installed, comfortable.

**Conclusions/action items:** This is a life jacket design, action: create a better version of this design and incorporate it with others



## 10/23/20 Research on speakers

---

ELIJAH MCCOY - Oct 23, 2020, 1:31 AM CDT

**Title: Research on Speakers****Date:** 10/23/20**Content by:** Elijah**Present:** Elijah**Goals:** to find speakers that would be suitable for our vest design**Content:**

Adafruit mini metal speaker w/ wires

<https://www.adafruit.com/product/1890>

- 1 inch diameter
- lightweight
- simple
- 0.5 W or less of power
- adafruit has a lot of other speakers as well
- just under 2 dollars so cheap

adafruit oval speaker with short or long wires

<https://www.adafruit.com/product/4227>

- much like the other adafruit speaker
- small, lightweight, and simple
- 1 W or less power
- easy to plug into a board

Sena technologies slim speakers

<https://www.jpcycles.com/product/400-3067/sena-technologies-smh10r-slim-speakers>

- meant for cycling
- small and slim
- 32 mm diameter
- speaker adhesives included
- 25 dollars
- 2 speakers connected

Zulu Audio Alpha wearable speakers

<https://shop.popsoci.com/sales/wearable-speakers-white>

- 43 dollars so more expensive
- bluetooth
- more of a consumer product
- attach using magnets connected to clothing
- built in rechargeable battery
- 4 hours of playtime
- pairable to a computer or phone

Rockler Single Wireless Speaker Kit

<https://www.rockler.com/rockler-wireless-speaker-kit-with-playback-volume-controls>

- kit to make speaker
- a bit bulky may not fit in vest
- 20 dollars for 1 speaker
- bluetooth
- internal rechargeable battery

**Conclusions/action items: a few speakers that may be used in our design, action item will be to present to group and see if we need to research more speakers, also need to know what the quality of speakers needs to be**



## 10/29/20 Adafruit

---

ELIJAH MCCOY - Oct 29, 2020, 2:09 PM CDT

**Title:** Adafruit

**Date:** 10/29/20

**Content by:** Elijah McCoy

**Present:** Elijah McCoy

**Goals:** To find boards to be used in our vest design

**Content:**

Adafruit Audio FX Sound Board

- 16 mb flash
- 11 triggers
- no arduino required
- very small 2 by 1 inch roughly
- high quality sound
- 25 dollars each

this seems like a very good option for our project, we would probably get 3 of these, 1 for heart sounds, 1 for left lung sounds, and 1 for right lung sounds.

**Conclusions/action items:** Buy the boards/figure out circuitry and how we will work with them



## 11/12/20 Vest Research

ELIJAH MCCOY - Nov 12, 2020, 3:11 PM CST

**Title:** Vest Research

**Date:** 11/12/20

**Content by:** Elijah

**Present:** Elijah

**Goals:** To find a vest that would be suitable for our electronics

**Content:**

Flygo Men's Vest

[https://www.amazon.com/Flygo-Lightweight-Outdoor-Fishing-Pockets/dp/B07S2DT838/ref=sr\\_1\\_14?dchild=1&keywords=hunting-vests&qid=1605210908&sr=8-14](https://www.amazon.com/Flygo-Lightweight-Outdoor-Fishing-Pockets/dp/B07S2DT838/ref=sr_1_14?dchild=1&keywords=hunting-vests&qid=1605210908&sr=8-14)

- Has a decent amount of pockets
- Would require some cuts and holes
- Zipper
- mesh for comfort
- 30 bucks
- nylon fabric
  - not waterproof

Gihuo Vest

[https://www.amazon.com/Gihuo-Leisure-Outdoor-Pockets-Journalist/dp/B073SVT78C/ref=zg\\_bs\\_19562678011\\_4?\\_encoding=UTF8&psc=1&refRID=SE9AKMZ8EXBPYVJJJKJH](https://www.amazon.com/Gihuo-Leisure-Outdoor-Pockets-Journalist/dp/B073SVT78C/ref=zg_bs_19562678011_4?_encoding=UTF8&psc=1&refRID=SE9AKMZ8EXBPYVJJJKJH)

- good amount of pockets on the front
- no pockets on back
- zipper in front
- lightweight
- 27 dollars
- cotton and polyester
- mild waterproof

ULINE Vest

[https://www.uline.com/Product/Detail/S-23373G-4X/High-Visibility-Clothing/Class-2-Solid-Vest-Lime-4XL-5XL?pricode=WB9547&gadtype=pla&id=S-23373G-4X&gclid=CjwKCAiA17P9BRB2EiwAMvwNyc2NiHfzHgvNKjRhWnWY2BHLWU5W53nGCyS0dMPYRQv7j7qTOe-IABoCufsQAvD\\_BwE&gclsrc=aw.ds](https://www.uline.com/Product/Detail/S-23373G-4X/High-Visibility-Clothing/Class-2-Solid-Vest-Lime-4XL-5XL?pricode=WB9547&gadtype=pla&id=S-23373G-4X&gclid=CjwKCAiA17P9BRB2EiwAMvwNyc2NiHfzHgvNKjRhWnWY2BHLWU5W53nGCyS0dMPYRQv7j7qTOe-IABoCufsQAvD_BwE&gclsrc=aw.ds)

- no pockets
- would have to add pockets
- 10 dollars
- lightweight
- basically a baseline vest that we could add stuff to
- polyester
- machine washable

**Conclusions/action items:** Find a vest that can hold all the electronics while still being able to be sterilized



# Most Common Lung Problems

---

Tim TRAN - Sep 17, 2020, 7:23 PM CDT

## **Title: Most Common Lung Problems**

**Date:** 9 / 17 / 2001

**Content by:** Tim Tran

**Present:** Tim

**Goals:** To better understand what sort of conditions the vest will have to simulate.

**Content:**

### **Asthma**

- Inflammation of the airways leads to difficulty breathing
- Symptoms
  - Dry cough
  - Wheezing
  - Chest tightness
  - Shortness of breath

### **Chronic Obstructive Pulmonary Disease (COPD)**

- The general term for several respiratory illnesses
- Symptoms
  - Breathlessness
  - Inability to breathe out
  - Cough up mucus from lungs
- The disease shows up when people are in their 30s and 40s
- The disease peaks during ages 50 and beyond
- Associated with smoking
- Irreversible
- The third leading cause of death in the U.S

### **Chronic Bronchitis**

- Form of COPD
- Symptoms
  - Cough up mucus from lungs, common occurrence during mornings
  - Chronic cough

### **Emphysema**

- Form of COPD
- The most common cause is smoking
- Symptoms
  - Trouble exhaling air
- Leads to respiratory failure
- Evolves slowly over the years and is incurable

### **Lung Cancer**

- Uncontrolled growth of abnormal cells (tumor) preventing the function of lungs
- Symptoms
  - Chronic coughing
  - Changes in voice
  - Harsh breathing sounds
  - Coughing up blood
- Lung cancer is the leading cause of cancer death in the U.S

### **Cystic Fibrosis/Bronchiectasis**

- Defective gene - genetic respiratory disease
- Symptoms



- Thick and sticky mucus clogs up passageways
- Mucus leads to repeat lung infections
- The mucus creates blockages in the pancreas which prevents enzymes from breaking up nutrients in the body
- Salty skin
- Chronic cough
- Poor growth rate
- Wheezing
- Shortness of breath

### **Pneumonia**

- Infection in air sacs of lungs
  - Can be bacterial, viral, or fungal
- Severity range from 1-3 week recovery time to life-threatening
- Symptoms
  - Fever
  - Chills
  - Cough
  - Mild to severe shortness of breath

### **Conclusions/action items:**

There are many commonly found lung problems with many sharing the same symptoms. Now that I have learned about some lung problems, I can now research how to diagnose each symptom based on cough sounds. This will be important for the vest as it will have to simulate lung conditions. I will also research how the current sim-man simulates lung conditions.

source: Unitypoint.org. n.d. *The Top 8 Respiratory Illnesses And Diseases*. [online] Available at: <<https://www.unitypoint.org/homecare/article.aspx?id=2448b930-1451-43e4-8634-c0c16707c749>> [Accessed 17 September 2020].



# Acoustic Methods for Pulmonary Diagnosis

Tim TRAN - Sep 23, 2020, 4:53 PM CDT

**Title:** Acoustic Methods for Pulmonary Diagnosis

**Date:** 9/23/2020

**Content by:** Tim Tran

**Present:** Tim Tran

**Goals:** Hearing and being able to diagnose different lung diseases

**Content:**

## Techniques

- Auscultation: listening to breath sounds
- Percussion: tapping of chest
- Tactile Fremitus: assessment of vibrations traveling through the chest

All these techniques are commonly used for preliminary diagnosis of lung diseases because they are quick and inexpensive. However, these techniques suffer from subjectivity and the high amounts of training required to effectively analyze the signals to make a diagnosis.

## Categories

- The lung can be abnormally occupied by fluid or air

## Pneumonia

- Accumulation of fluid in the lungs
  - Results in abnormal breath sounds and dullness to percussion

## Asthma and COPD

- Traps air in the chest
  - Wheezes

## Types of Acoustic Signals

- Internal signals
  - sounds produced during breathing and vocal cords
- External signals
  - results from chest percussion and airway insonification (flooding the lungs with sound waves for imaging)

We should focus on internal signals for the vest as external signals came from machinery.

## Internal: Breath Sounds

- **Crackles (Rales)**
  - short, high-pitched crackling sound caused by air passing through fluid, pus, or mucus
  - can be coarse or fine
    - coarse crackles are louder and lower in pitch and the sound lasts longer
  - correlated to COPD, pneumonia, fibrosis, and bronchiectasis
  - <https://www.youtube.com/watch?v=aSor2XBc9K8> (coarse)
  - <https://www.youtube.com/watch?v=LHqqvrm2j6g> (fine)
- **Wheezes**
  - high pitched whistling noise when breathing in or out
  - correlated to asthma and COPD
  - <https://www.youtube.com/watch?v=T4qNgi4Vrvo>
- **Rhonchi**
  - low pitched wheezing when breathing out
    - sounds like snoring
  - sign that bronchial tubes are thickening because of mucus
  - correlated to bronchitis and COPD
  - <https://www.youtube.com/watch?v=YgDiMpCZo0w>
- **Stridor**
  - harsh, noisy, squeaking sound that comes with every breath

- can be high or low pitched
- sign that something is blocking airway
- <https://www.youtube.com/watch?v=JSdEK79J4dw>
- **Squawks**
  - mixture of a crackle followed by a wheeze
  - correlated to fibrotic pulmonary disorder
- **Bronchial**
  - hollow sounding breaths present in both inhale and exhale
  - loud
  - <https://www.youtube.com/watch?v=WfkWMfE9VTY>

**Conclusions/action items:**

Now that we have a small understanding of lung diseases and scratched the surface on being able to identify them based on sounds, we can now make design decisions on how these lung sounds will be implemented.

The article has another section of internal signals dealing with vocal sounds which will be another entry in the notebook.

A. Rao, E. Huynh, T. J. Royston, A. Kornblith, and S. Roy, "Acoustic Methods for Pulmonary Diagnosis," *NCBI*, 2019. [Online]. Available: <https://www.ncbi.nlm.nih.gov/pmc/articles/PMC6874908/>. [Accessed: 23-Sep-2020].



## Heart and Lungs Sound Library

---

Tim TRAN - Oct 21, 2020, 9:54 PM CDT

**Title:** Heart and Lung Sound Library

**Date:** 10/21/2020

**Content by:** Tim Tran

**Present:** Tim Tran

**Goals:** Find a library of sounds for which our vest speakers can output.

**Content:**

<https://www.medzcool.com/auscultate>

This is the link to the information page of a medical sound library. The library is created by Medzcool. It is \$20 for the library of sounds along with many extra features meant for learning. The sounds include normal heart and lung sounds and many abnormal heart and lung sounds due to various diseases.

**Conclusions/action items:**

I am unsure if we will be able to download and use the audio found in this library the way we want to, but the library would provide us with most of the sounds we would need/want.



## Tips for running wire through garments

---

Tim TRAN - Dec 09, 2020, 11:07 AM CST

**Title:** Tips for running wire through garments

**Date:** 12/9/2020

**Content by:** Tim Tran

**Present:** Tim Tran

**Goals:** Learning about techniques and helpful tips for running wires through our sim vest.

**Content:**

The best approach for most clothing items is to "hand-sew the wire to the fabric with fishing line." We should tie an extra knot in the fishing line every 5-6 inches, so if one part breaks, the rest of the stitching will not unravel.

Another approach to running the wires could be to sew on a casing for the wires made out of fabric. (This approach might be more useful for our vest, as we must be able to sanitize the vest. The casing could be made out of water repellent material to protect the wiring left in the vest.)

We must stitch anchor points where the wire bends such as the armpits in order to allow the wires some slack to move back and forth ensuring the wearer of the vest can move freely without being pulled by the wiring.

The battery pocket should be close to the size of the battery, so the battery is not bouncing around when the vest is in motion. The wires should be passed through a slit cut into the pocket that will be resown so the pocket's integrity is maintained.

**Conclusions/action items:**

**We now have a solid starting point and a few techniques to learn about when building our vest.**

**Title:** Initial design

**Date:** 9/23

**Content by:** Tim Tran

**Present:** Tim Tran

**Goals:** Brainstorm ideas for the vest

**Content:** Sketch of vest idea

**Conclusions/action items:**

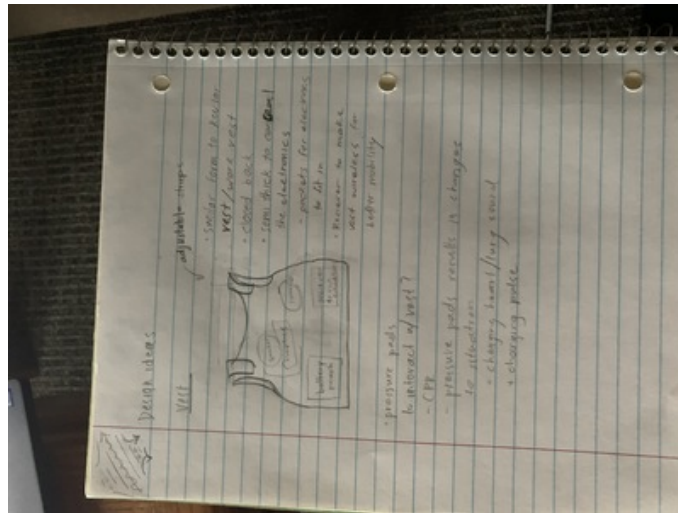

File\_000.jpeg(2.5 MB) - [download](#)



## 2014/11/03-Entry guidelines

---

John Puccinelli - Sep 05, 2016, 1:18 PM CDT

Use this as a guide for every entry

- Every text entry of your notebook should have the **bold titles** below.
- Every page/entry should be **named starting with the date** of the entry's first creation/activity, subsequent material from future dates can be added later.

You can create a copy of the blank template by first opening the desired folder, clicking on "New", selecting "Copy Existing Page...", and then select "2014/11/03-Template")

**Title:** Descriptive title (i.e. Client Meeting)

**Date:** 9/5/2016

**Content by:** The one person who wrote the content

**Present:** Names of those present if more than just you (not necessary for individual work)

**Goals:** Establish clear goals for all text entries (meetings, individual work, etc.).

**Content:**

Contains clear and organized notes (also includes any references used)

**Conclusions/action items:**

Recap only the most significant findings and/or action items resulting from the entry.



**Title:**

**Date:**

**Content by:**

**Present:**

**Goals:**

**Content:**

**Conclusions/action items:**