



# Microscope Low-Cost Motorized Stage

**Team members:** Mateo Silver (Leader), Shreya Godishala (Communicator), Darshigaa Gurumoorthy (BSAC), Emily Wadzinski (CO-BWIG), Nikhil Chandra (CO-BWIG), Sam Tan (BPAG)

**Advisors:** Dr. Kip Ludwig, Dr. James Trevathan

**Client:** Dr. John Puccinelli

**Date:** October 7, 2022

# Presentation Overview

- Problem Statement
- Background Material
- Product Design Specifications
- Competing Designs
- Preliminary Designs
- Design Matrix
- Future Work
- Acknowledgements

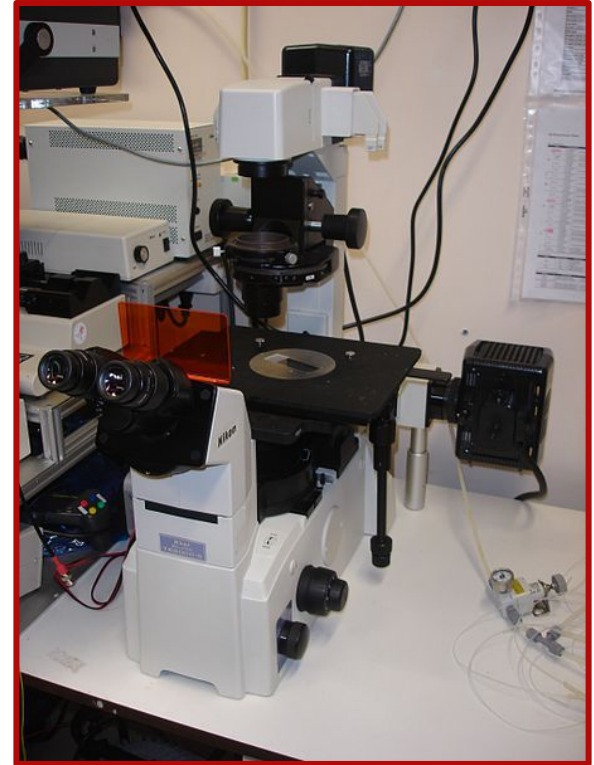

Inverted Fluorescence  
Microscope [1]  
Wikimedia.org

# Client & Problem Statement

- Client
  - Dr. John Puccinelli (Associate Chair of the Undergraduate Program and Associate Teaching Professor)
  - Needs a low-cost effective motorized stage for use in the teaching labs.
- Problem Statement
  - The current inverted fluorescent microscopes have fixed stages only movable by manual knobs which is difficult to imaging and control. The new designed stage should add features such as automatic controls to lower the difficulty of using the microscope while keeping precise and low cost.



Dr. John Puccinelli [2]  
bmedesign.engr.wisc.edu

# Background Material

- Inverted fluorescent microscopes have a light source and a condenser on the top
- The stage of an inverted microscope is usually fixed and the focus is adjusted by moving the objective lens
- These microscopes are useful for studying biological samples with high magnification

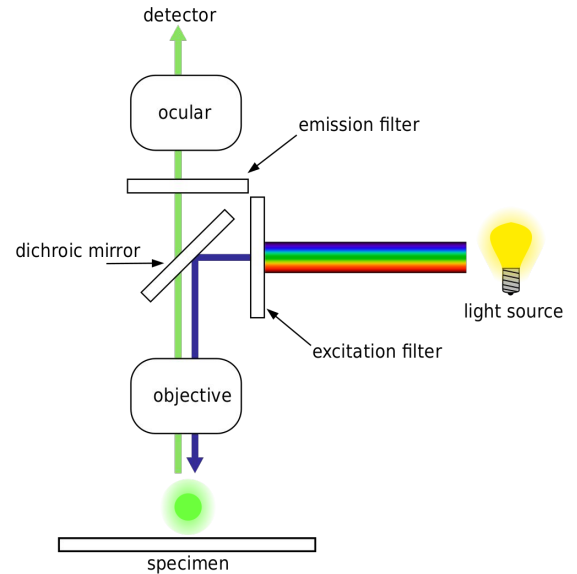

Fluorescence Microscope  
Diagram [3]

Wikimedia.org

# Product Design Specifications

- **Client Requirements:**
  - A motorized stage that is compatible with rest of the microscope
  - Cost of the product to be within \$100.
  - Use 3D printing and laser cutting.
  - Capable with Nikon Elements imaging software.
  - Resolution of the movement is around 1  $\mu\text{m}$ .

# Competing Designs

- **Nikon TI-U Motorized [4]**
  - Current lab microscope - Nikon TI-U
  - Base vs Motorized model
  - Base: \$16k used [5]
  - Motorized: ~\$70k new, \$19k used [4]
- 
- **Openstage [6]**
  - Open source design
  - Under \$1,000
  - 1 $\mu$ m accuracy in x and y axes



Motorized Version of  
Current Teaching Lab  
Microscope [7]

Nikon.com

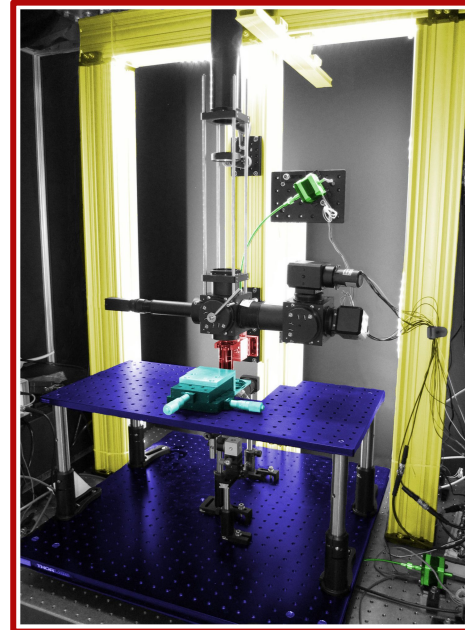

Openstage [6]

PLOS One

# Design 1: Previous Design

- Design from Spring 2022
- Worm gears interfacing with control knobs
- Slides on track
- Bulky and less accurate

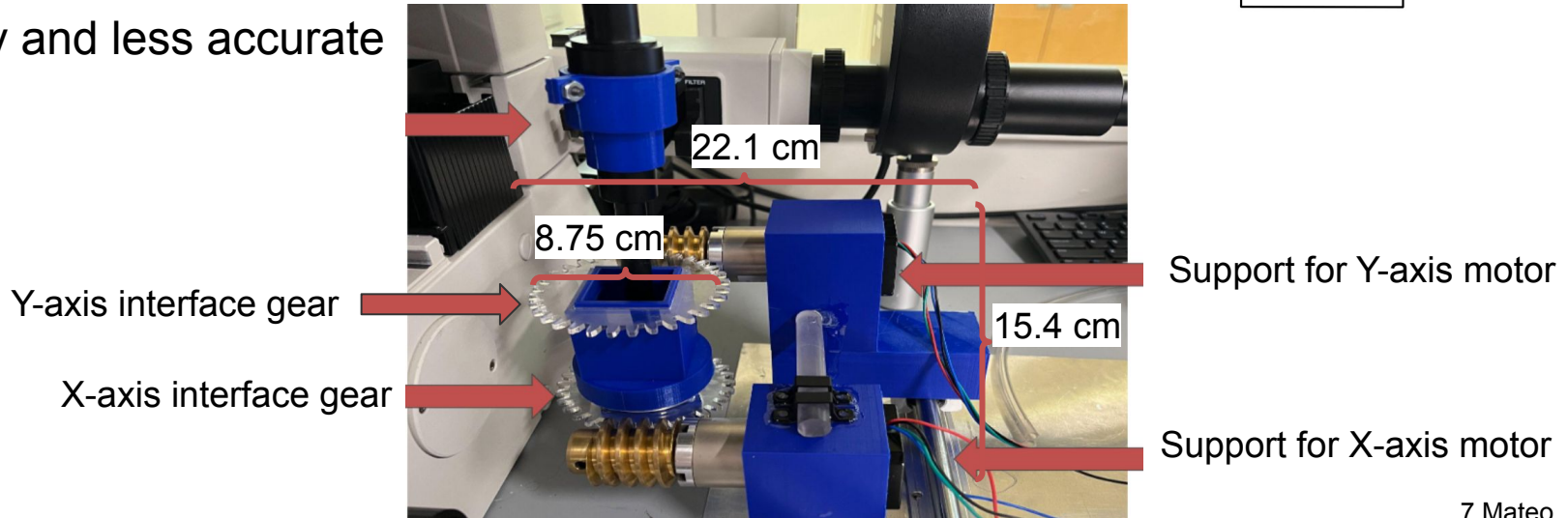
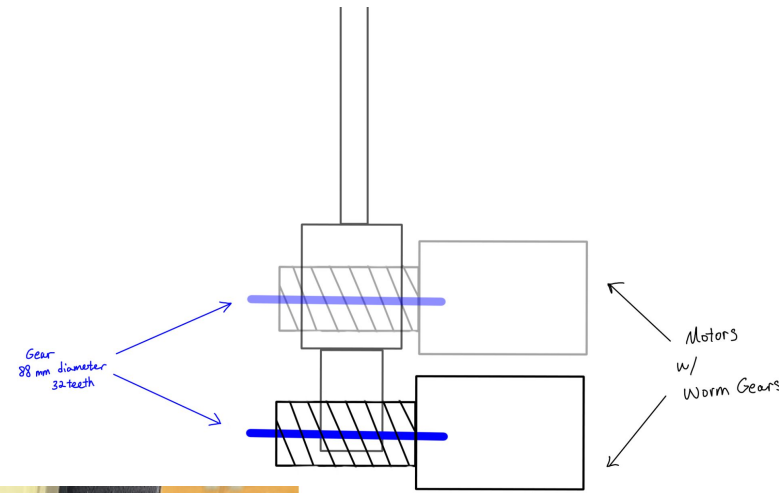

# Design 2: Chain Drive

- This design implements two chains to move gears connected to the x and y knobs, which are then connected to two motors on a rail.
  - Expected Length of Chain: 12-15cm
  - Gear Specifications: 88mm diameter with 32 teeth
  - Motor: Two Planetary 100:1 Gearbox Nema 17 Stepper Motors from Stepperonline
- Chain is used to avoid direct contact between the gears on the motor and the gears on the knob to achieve less interaction.

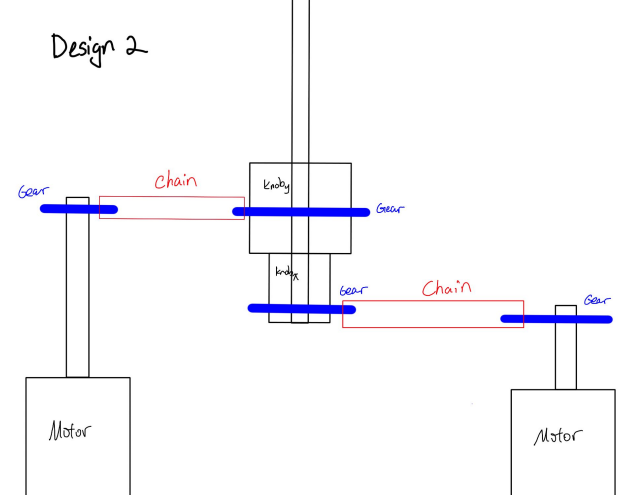

Design 2

Gear ratio  
88mm diameter : 32 teeth

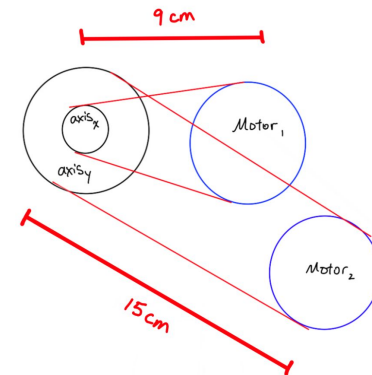



# Design 3:

- Similar to chain sprocket design, 2 motors, 4 gears
- Gears meshed directly to knob gears
- Lower cost without chains, however potential for misalignment

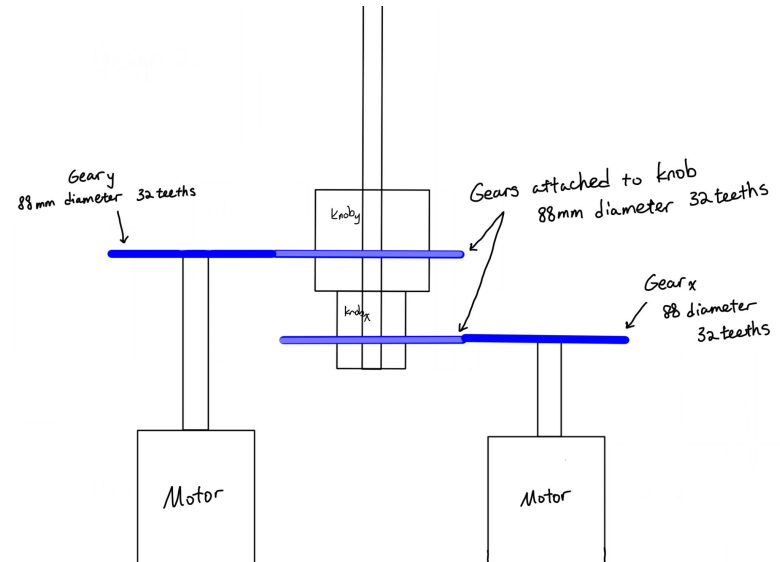

# Design Matrix

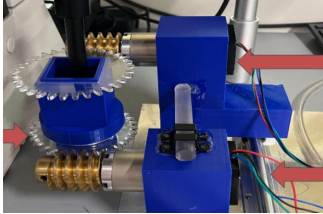
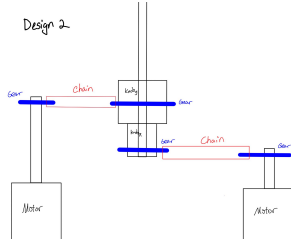
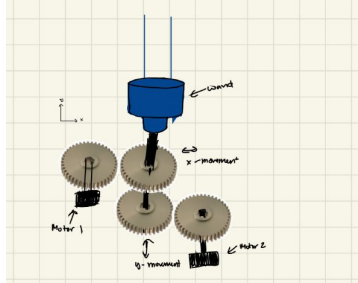
Criteria	Design 1: Previous Design	Design 2: Chain Drive	Design 3: Gear to gear
			
Functionality (25)	$4/5 * 25 = 20$	$3/5 * 25 = 15$	$4/5 * 25 = 20$
Size (25)	$2/5 * 25 = 10$	$4/5 * 25 = 20$	$5/5 * 25 = 25$
Ease of Fabrication (20)	$5/5 * 20 = 20$	$3/5 * 20 = 12$	$4/5 * 20 = 16$
Cost (20)	$5/5 * 20 = 20$	$3/5 * 20 = 12$	$4/5 * 20 = 16$
Aesthetics (5)	$4/5 * 5 = 4$	$5/5 * 5 = 5$	$3/5 * 5 = 3$
Safety (5)	$5/5 * 5 = 5$	$4/5 * 5 = 4$	$5/5 * 5 = 5$
Total = 100	<b>79 / 100</b>	<b>69 / 100</b>	<b>85 / 100</b>

# Conclusion & Future Work

- Design 3: Gear to Gear was chosen to move forward with.
  - Scored highest in design matrix.
  - Potential to be more compact and accurate.
- Start development of Design 3.
  - Calculate its potential resolution of the movement.
    - Compare to Previous Design 1's accuracy to see if Design 3 will be more precise.
  - Buy materials needed.
  - Work on connecting Nikon Elements Software to device.

# Acknowledgements

- To our advisors
- To our client
- To our peers



Left - Dr. Kip Ludwig  
Center- Dr. John Puccinelli  
Right - Dr. James Trevathan [2]  
[bmedesign.engr.wisc.edu](http://bmedesign.engr.wisc.edu)

# References

- [1] N. Nogueira , "File:Inverted microscope.jpg," Wikimedia, 25-Sep-2007. [Online]. Available: [https://commons.wikimedia.org/wiki/File:Inverted\\_microscope.jpg](https://commons.wikimedia.org/wiki/File:Inverted_microscope.jpg). [Accessed: 05-Oct-2022].
- [2] "Advisors," BME Design UW Madison. [Online]. Available: <https://bmedesign.engr.wisc.edu/course/advisors>. [Accessed: 06-Oct-2022].
- [3] Henry Mühlpfordt, "File:FluorescenceFilters 2008-09-28.svg," Wikimedia, 28-Sep-2008. [Online]. Available: [https://commons.wikimedia.org/wiki/File:FluorescenceFilters\\_2008-09-28.svg](https://commons.wikimedia.org/wiki/File:FluorescenceFilters_2008-09-28.svg). [Accessed: 07-Oct-2022].
- [4] "Nikon TI-u inverted fluorescence motorized microscope pred ti2 - AV," Boston Industries, Inc. [Online]. Available: <https://www.bostonind.com/nikon-ti-u-inverted-fluorescence-motorized-microscope-pred-ti2-av>. [Accessed: 05-Oct-2022].
- [5] "Nikon Ti-U Inverted Fluorescence Microscope Pred Ti2," Boston Industries, Inc. [Online]. Available: <https://www.bostonind.com/nikon-ti-u-inverted-fluorescence-microscope-pred-ti2>. [Accessed: 05-Oct-2022].
- [6] R. A. A. Campbell, R. W. Eifert, and G. C. Turner, "Openstage: A low-cost motorized microscope stage with sub-micron positioning accuracy," PLOS ONE, 26-Feb-2014. [Online]. Available: <https://journals.plos.org/plosone/article?id=10.1371%2Fjournal.pone.0088977>. [Accessed: 05-Oct-2022].
- [7] "Eclipse Ti2 Series," Nikon Instruments Inc. [Online]. Available: <https://www.microscope.healthcare.nikon.com/products/inverted-microscopes/eclipse-ti2-series>. [Accessed: 05-Oct-2022].
- [8] W. B. P. E. E. H. E. J. P. JM; "Free and open-source automated 3-D microscope," *Journal of microscopy*. [Online]. Available: <https://pubmed.ncbi.nlm.nih.gov/27571224/>. [Accessed: 06-Oct-2022]
- [9] Dinesh Jackson Samuel R;Rajesh Kanna B; "A programmable microscopic stage: Design and development," *Microscopy research and technique*. [Online]. Available: <https://pubmed.ncbi.nlm.nih.gov/30575202/>. [Accessed: 06-Oct-2022].
- [10] "Electrothermal fluid manipulation of high-conductivity samples for ..." [Online]. Available: <https://journals.sagepub.com/doi/10.1016/j.jala.2010.05.004>. [Accessed: 06-Oct-2022].