

# **SmHeart Headphones Final Report**

December 14, 2022

BME 200/300

Leader: Ethan Hannon

BSAC: Rachel Nossen

BPAG: Mark Rice

BPAG: Mustafa Al-Sakhbouri

Communicator: Carson Endries

BWIG: Kyle Everson

Advisor: Dr. Justin Williams

Client: Dr. Jeffrey Koziol

## **Abstract**

The team was given the task to properly monitor and record the pulse wave velocity and pulse transit time of an individual in order to properly determine their blood pressure and overall cardiovascular health. Current devices, such as the blood pressure cuffs, already exist to measure blood pressure but require manual use and do not continuously measure blood pressure over long periods of time. Smart watches alone are capable of tracking pulse, but they tend to remain inaccurate in their overall tracking analysis. The proposed solution would be an over the ear headphone design that utilizes a microphone to listen to the user's heartbeat. This device would be capable of measuring the pulse transit time via the time between the recording of the heartbeat and the pulse being picked up by a connected smartwatch via bluetooth. Initial testing of the prototype would utilize three methods. The first would track the microphone's ability to cancel out outside noises in order to focus on the sound of the heartbeat. The second test would then see how accurate the data collection is compared to a blood pressure cuff. The intended results should thus display the headset being capable of ignoring outside noise and being able to listen and track blood pressure levels in a similar accuracy to that of blood pressure cuffs. Intended results should show little to no variance data blood pressure tracking between headphones and existing devices as well as efficiently ignoring outside noises.

## Table of Contents

<b>Abstract</b>	<b>2</b>
<b>Table of Contents</b>	<b>3</b>
<b>I. Introduction</b>	<b>4</b>
<b>II. Background</b>	<b>4</b>
Physiology and Biology	4
Explaining Blood Pressure	5
Current Styles of Measuring Blood Pressure	5
Clinical Significance	6
Client	6
Product Design Specifications	6
<b>III. Preliminary Designs</b>	<b>7</b>
Design #1 Headband	7
Design #2 Wrap Around	8
Design #3 Gamer Headphones	9
<b>IV. Preliminary Design Evaluation</b>	<b>10</b>
Design Matrix	10
Proposed Final Design	12
<b>V. Fabrication/Development Process</b>	<b>12</b>
Arduino Materials	12
Headphone Materials	12
Methods	13
Final Headphones Prototype	13
Final Smartwatch Prototype	14
Microphone Testing	15
Data Testing	16
LED Arduino Circuit Testing	16
<b>VI. Results</b>	<b>17</b>
LED Arduino Circuit Results	17
LED Arduino Circuit Discussion	19
<b>VIII. Conclusion</b>	<b>22</b>
<b>IX. References</b>	<b>23</b>
<b>X. Appendix</b>	<b>24</b>
Appendix A: Product Design Specifications (PDS)	24
Appendix B: Final Expenses and Materials List	27
Appendix C: Final Arduino HRM Circuit Code	34

## **I. Introduction**

Over the past couple of years, since the outbreak of COVID-19, high blood pressure has been on the rise for much of the U.S. population [1]. In order to properly track and identify cases of high blood pressure, tools such as blood pressure cuffs and pulse tracking technologies (smart watches, phones, etc.) are used to tackle this problem. However, such devices tend to be unable to provide constant, accurate tracking of blood pressure over a prolonged period of time. Many smart watches in this case are only about 34% accurate when tracking pulse [2]. Moreover, blood pressure cuffs that are most often seen in clinical settings aren't practical for constant tracking throughout the day. This project will focus on developing an accurate, easy-to-use headphone device that is capable of continuously measuring blood pressure while providing statistical representation of their data through an app. The cost effective design of this device will also provide practical usage for much of the population.

There currently exist no on the market products that measure PTT and PWV using a microphone, however some smart headphones measure pulse using a LED sensor similar to the one used in the circuit in Figure 9. Using a LED sensor is more cost effective, less susceptible to outside interference and generally easier to implement. Using a microphone instead provides the benefit of being able to hear the actual heart sound, but at the cost of susceptibility to background noise especially in headphones where music will be played at the same time. Low frequency microphones are also more expensive, it would be recommended for a project like this in the future to look into fabrication of a custom low frequency microphone for this application.

The team has been tasked by the client to design and develop headphones to record a cardiac pulse signal and pair this with a smart watch to measure PTT and PWV. The design of the headphones should be small and portable with a microphone that would be attached instead of a speaker. A bluetooth link to the user's watch and phone with the headphones will be required. Both the headphone and the user's watch will create a pulse that should thus measure the Pulse Transit Time and Pulse Wave Velocity of the body. This data will be recorded and shown on an app that can be accessed by the user on their phone or smart watch. The design of the headphones should be similar to that of Apple airpods and should work with ios systems.

## **II. Background**

### *Physiology and Biology*

The most relevant biology to this project is the circulatory system since the purpose of the project is to measure information related to blood circulation. The most accessible sites near where headphones could be worn would be the temples or the carotid artery. If a microphone is in use the carotid artery would be the best site to hear as the pulse passes through, however due to its proximity to the esophagus there may be interference with the sounds of breathing or speaking. If a LED sensor were to be used the temples would be the most ideal site near the ears since blood travels very close to the surface of the skin there.

### *Explaining Blood Pressure*

Blood pressure is defined as the pressure exerted on a person's arterial walls. This can be split into two types of pressure, systolic and diastolic. Systolic pressure is the pressure your blood exerts against one's artery walls when the heart beats. During this time, blood pressure is at a peak pressure value. Diastolic is the opposite of systolic, this value indicates how much pressure your blood exerts against your artery walls while the heart is between beats [3]. A general range for blood pressure ranges from less than 120 mm Hg over less than 80 mmHg ( $\approx 16\text{kPa}/10.7\text{kPa}$ ) [4] with the first number being the systolic pressure and the second one being diastolic. High blood pressure is

### *Pulse Wave Velocity and Pulse Transit Time*

Pulse wave velocity is the speed at which blood travels from one arterial node of the body to the other. It can be utilized in blood pressure applications for its direct correlation between the two as the higher the blood pressure, the higher the pulse wave velocity [5]. This correlation is due to the same amount of blood being pushed through an increasingly smaller tubular space thus causing pressure to increase. Pulse transit time is the time blood takes to travel from one arterial node to the other. To track this, it is possible to simply listen or feel for the heartbeat and then track how long it takes to feel that same pulse somewhere else in the body. To connect these two measurements, a simple equation can be used [5]:

$$PWV = \frac{\text{Distance between nodes}}{PTT}$$

### *Current Styles of Measuring Blood Pressure*



Figure 1. Blood Pressure Cuff

Currently, blood pressure is commonly measured by a blood pressure cuff (Figure 1). However, this method is considered uncomfortable by most. It requires someone else to operate the device and record the measurements. Because of its accuracy, it is used by professionals in a clinical setting. There are far significantly more smart watches on the market that are able to measure pulse than those that are able to measure blood pressure. Current digital cuffs on the market still lack comfortability and are far less accurate than those found in a clinical sound.

### *Clinical Significance*

A constant measurement of blood pressure would give a better idea into one's own heart health and would provide more insight into when high blood pressure situations occur. PTT and PWV are both good indicators of blood pressure and being able to have convenient measurement of this data could provide an earlier insight into worrying circulatory health conditions.

### *Client*

Dr. Jeffrey Koziol is an ophthalmologist with 48 years of experience in the medical field [6]. He is interested in creating smart headphones for patients with elevated blood pressure to help them monitor their own health.

### *Product Design Specifications*

The client had asked that headphones be designed and fabricated that would be capable of pairing with a second device and measuring the user's Pulse Wave Velocity and Pulse Transit Time through a microphone. Because the measurements are taken by a microphone, background noise must be blocked out. The headphones must also contain speakers, so that the user can use them like ordinary headphones. When designing these headphones, it is important that the headphones should have similar mass and size to that of average headphones on the market. The measurements taken should be recorded on an app or program for the user to reference. For more information, see the Full PDS in Appendix A.

### III. Preliminary Designs

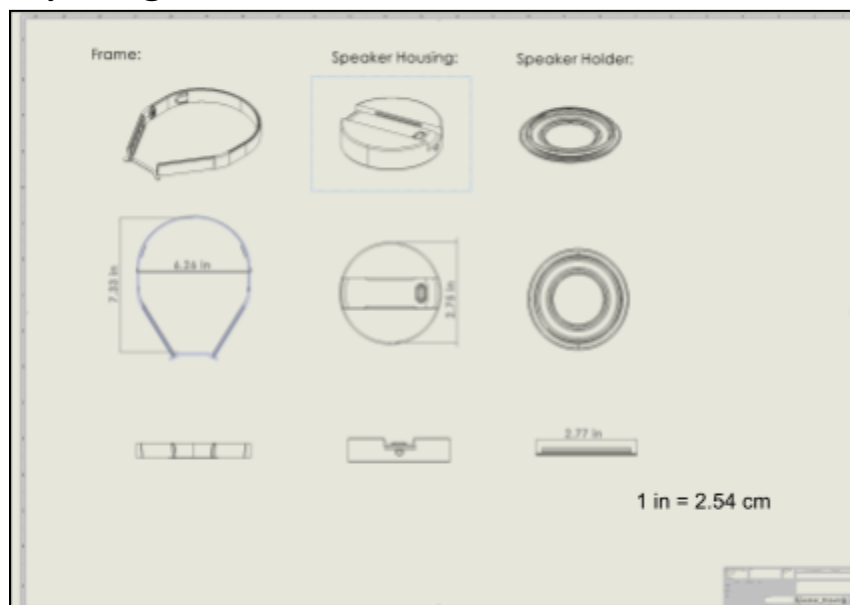

Figure 2. Drawing of Design #1

#### *Design #1 Headband*

The headband design is an addition onto a pair of traditional style over the ear headphones that would have a microphone attached near the base of the padding around one of the ears. This would allow an auditory input to be taken along the carotid artery. This digital signal could be transmitted via bluetooth to the smartphone where calculations would be done to calculate the PTT and PWV.

An advantage of using this design is that it would allow the microphone signal to be encased within the sound canceling barrier. This would allow a minimized need for algorithms used to isolate the heart beat signal. It is also a commonly used design on the market, so it is known that this design is comfortable and safe.



Figure 3. Drawing of Design #2

#### *Design #2 Wrap Around*

The wrap around design is a modified version of in-ear earbuds that wrap around the ear. A microphone would be installed to the tip of the earbud and would be used to capture the user's heartbeat. An LED would also be added to the earbud that would be used in combination with a smartwatch to record the user's heart rate using a PPG signal.

This lightweight design would provide comfort and security to the user. However, the small, complex parts would result in a more difficult fabrication process. The in-ear design instead of over-the-ear would also result in more interference from outside noise, possibly making it difficult for the microphone to pick up the heartbeat.



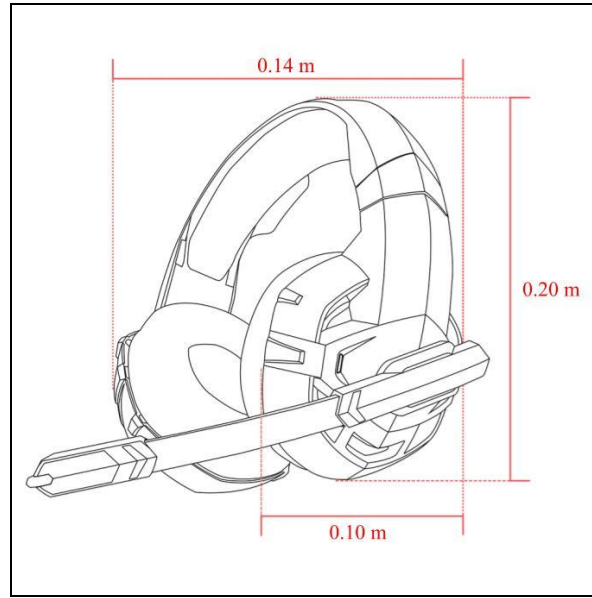

Figure 4. Drawing of Design #3

### *Design #3 Gamer Headphones*

The gamer headphones design is a depiction of gaming headsets in shape and parts. The microphone that comes out from the left side of the headphone should be easily adjusted and reaches the artery area in the neck. The team will alter the programming system of a normal gaming headphone to add different modes. First mode will be the default mode such that the user would be able to use the microphone for inputting audio. Second mode would be the pulse hearing in which the microphone is adjusted next to the artery to record pulse sound. In the pulse hearing mode, the team will use computer algorithms to eliminate background noises and convert sound waves into PTT and PWV measurements.

The idea of this design is simple but it would be hard to implement due to the need to rely on algorithms. In addition, it would not be comfortable for the user to keep adjusting the microphone around different modes.

## IV. Preliminary Design Evaluation

### Design Matrix

		Design 1 - Headband		Design 2 - Wrap Around		Design 3 - Gamer Headphones	
							
Criteria	Weight	Score (10 max)	Weighted Score	Score (10 max)	Weighted Score	Score (10 max)	Weighted Score
Effectiveness of measurements	25	10	25	10	25	7	18
Ease of fabrication	20	10	20	6	12	10	20
Ease of use	20	7	14	10	20	6	12
Comfort	15	9	14	8	12	10	15
Cost	10	5	5	7	7	8	8
Safety	10	10	10	10	10	10	10
<b>Sum</b>	<b>100</b>	<b>Sum</b>	<b>88</b>	<b>Sum</b>	<b>86</b>	<b>Sum</b>	<b>83</b>

Table 1: Completed Design Matrix of the three preliminary designs

**Criteria 1: Effectiveness of measurements**

This was given the highest weight (25) because it was highly stressed by the client. It is extremely important that the design is able to measure the user's heart accurately. Design 1 was given a perfect score for this. This can be explained by the placement of the microphone inside the speaker housing. This location would allow the microphone to experience little to no disturbance from background noise which would tamper with the recordings. Design 2 was also given a perfect score because of the microphone's proximity to a spot on the ear that is responsible for highly accurate measurements. Design 3 was given a weighted score of 18/20 because of the microphone's susceptibility to exposure of background noise

**Criteria 2: Ease of fabrication**

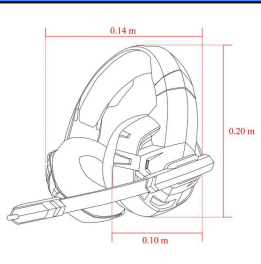
This was given a high valued weight (20) because it is an essential design requirement. Because of the amount of components that are involved in these headphones, it will be easier to start with headphones larger in size than ones that are smaller in size. This is why a perfect score was given to both Design 1 and Design 3. These designs are relatively similar in size; therefore, its fabrication process will be similar. Design 2 was given a lower score because of its smaller size. This could pose a problem because fitting many components in a smaller skeleton is difficult to perfect.

**Criteria 3: Ease of use**

This was given a relatively high weight of 20 due to its importance towards gathering accurate data. One of the main motivations for this project was to create a way of measuring blood pressure that is simple and can be done quickly. Also, due to the age range of the projected users, it is important that the technology be easy to understand. The wrap-around design was given a perfect score in this category because it would automatically connect and start gathering data as soon as it is placed in the ear. The headband design was given a lower score because it needs to be manually connected by the user. Finally, the gamer design was given the lowest score due to the complications with the different modes.

**Criteria 4: Comfort**

This was given a weight of 15 due to the criteria's importance for the user's experience while wearing the headphones. It is crucial that the user is still comfortable wearing the device while completing daily activities. However, this design aspect is less important than the overarching goal of obtaining accurate numbers. Design 2 was scored the lowest in this field because

**Criteria 5: Cost**

This was tied for the lowest weighted category because the team was given a high budget of \$5,000 for this project, so the difference in cost for each design would be relatively negligible. The gamer design was given the highest score in this category (8) because it involves simply modifying an already existing headset rather than starting from scratch. The wrap-around design

was given a slightly lower score for similar reasons, however the use of more complex parts combined with smaller design may result in more fabrication errors, thus driving the cost up. Finally, the headband design was given the lowest score of 5 because of the material cost of 3d printing the headset.

#### **Criteria 6: Safety**

This was tied for the lowest weighted category because, due to the nature of the project, none of the designs have any aspects that could really be considered unsafe. For that reason, each design was given a perfect score in this category.

#### *Proposed Final Design*

Due to its highest score on the design matrix, the proposed final design is the headband. Out of the three, this design has the best ability to reduce background noise which is imperative for getting proper measurements. It also will be comfortable for the user to complete daily activities with. Lastly, this design will be relatively easy to fabricate making it feasible for project completion.

## **V. Fabrication/Development Process**

### **Materials:**

#### *Arduino Materials*

For testing with an arduino a few types of microphones were used in order to finalize what kind will work best for minimizing background noise. Along with this a breadboard was used with wires, resistors, capacitors, operational amplifier and an auxiliary port for testing, wiring and listening to the microphone input or displaying the signal via the arduino.

Upon testing it was discovered that more types of microphones would be needed in order to find one that worked. The design also required LED heart rate sensors for simulating the data from a smart watch. For future development, research into low frequency (20 - 75 Hz) microphones is recommended.

#### *Headphone Materials*

The preliminary design of the headphones was 3D printed using TPU, thermoplastic polyurethane. This material was chosen due to its flexibility and elasticity [11]. The second design of the headphones was 3D printed using ABS, acrylonitrile butadiene styrene. This is because it is widely accessible and fairly inexpensive compared to other plastics [10]. It also is stronger, more durable than TPU. The speaker/microphone housing will be covered with standard ear cushions compatible with average sized headphones. This will block out background noise and make the user's experience with these headphones as comfortable as possible.

### *Methods*

The methods for collecting will consist of 2 major sensors, the microphone in the headphones and the already in use heart rate sensor inside of the user's smart watch. Since the headphones will be designed with implementation with a variety of smart watches, much more freedom of data collection is possible with the microphone. The microphone is planned to be implemented inside the noise canceling cuff of the headphones such that effort put into isolating the heart rate signal is minimized. Any computing should be done within the program so the signal from the microphone input should be broadcast via bluetooth to the smartphone where it will do the calculations.

An LED heart rate sensor is used instead of connectivity with a smart watch for ease of use while testing. Using an LED sensor board shown in Figure 7, the design should be able to read the heart rate at the wrist using that circuit and using an on the market heart rate monitor on the other wrist be able to compare the amount of beats sensed on either in a given minute.

### *Final Headphones Prototype*

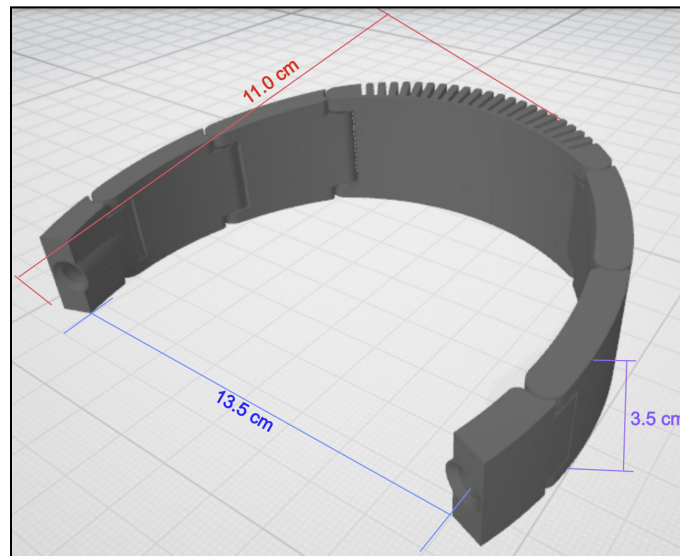

*Figure 5. 3D model of the Final Headphones' headband with dimensions*

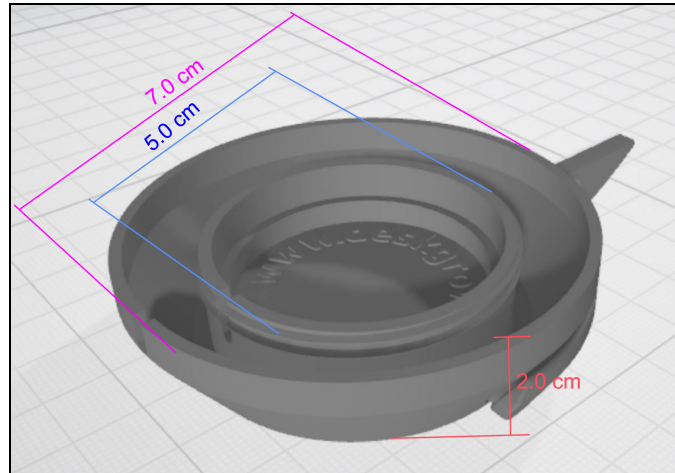

Figure 6. 3D model of the Final Headphones' cup with dimensions

As seen in Figure 5 and 6 is the final design for the headband and speaker cups for the headphones. The parts for the headphones included the headband, two cups (to house the electronics), two grills (to cover the electronics), two adjusters (to maximize user comfortability), two rotators, and two plugs (which connect the cup to the adjuster). All pieces were fabricated using a 3d printer with ABS filament. The prototype was unable to house the microphone due to its size; however, in future work it will be able to house a more compact system within its cup. In addition to the printed parts, soft ear pads were attached to the exterior of the grill to ensure comfort while wearing the headphones.

#### *Final Smartwatch Prototype*

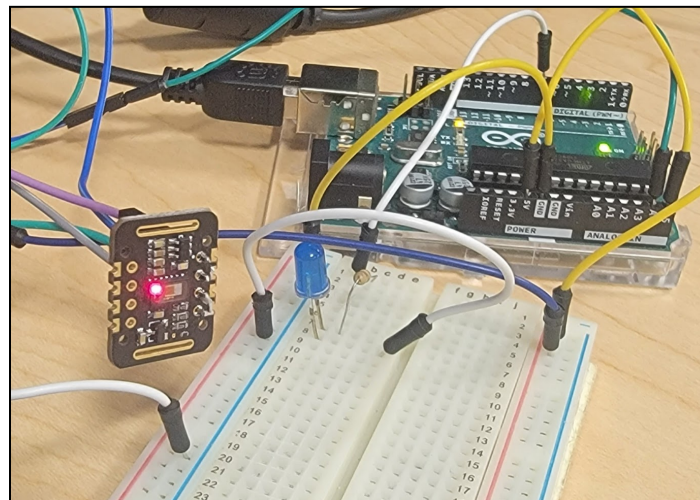

Figure 7. Photo of final Smartwatch Heart Rate Monitor Circuit

As seen in Figure 7 is the final circuit used to represent the smartwatch. Using data directly from a smartwatch was beyond the scope of this project for one semester so instead the circuit used in Figure 9 will represent heart rate data theoretically received from a smartwatch.

This used code (found in Appendix C) to light up a LED when it sensed a beat and had a beat counter for testing. Eventually this code would be adapted in conjunction with code from the smart headphones such that when the headphones sensed a beat it would start a timer, and when this smart watch sensed that same beat later it would end the timer. This time would be an estimate of PTT. Since this would be measuring a pulse traveling in two separate directions this uses the assumption that the arteries from the heart to the neck would have a similar PTT and PWV to the arteries going towards the wrist. This timer would give a PTT from the theoretical point equal distance from the heart to the neck instead of from the heart towards the wrist to the wrist. This would then take a measurement from user input estimating the distance from the heart to the wrist and multiply it by some constant found through testing to find the distance traveled between the theoretical PTT point and the wrist. It would divide that distance by PTT to get PWV. For the real PTT that is shown in the app it may be helpful to multiply it by a constant to get a value closer to the PTT from the heart to the wrist since this value can be compared with existing methods of measuring PTT and PWV.

### **Testing:**

Testing will occur in several stages, finding a suitable microphone in order to pick up heartbeat signals, designing the headphone enclosure such that it will comfortably sit in the location that will pick up this signal reliably, taking that input and estimating the PTT and PWV to estimate blood pressure and comparing that to a reading from a blood pressure cuff. Once all of these steps are proven to revise the design or calculations in order to make the final reading more accurate until it is within an acceptable range.

### *Microphone Testing*

The microphone's capability to accurately pick up and track the heartbeat will be tested by carrying out a series of tests involving the placement of the microphone on the neck and chest to record the heartbeat frequencies over the course of 30 seconds. This timeframe was chosen for the purpose of giving enough disparity in sound recording for heartbeat occurrences to be picked up more commonly when compared to background noise. The null hypothesis for this test will be that the microphone is incapable of accurately recording the heartbeat frequencies.

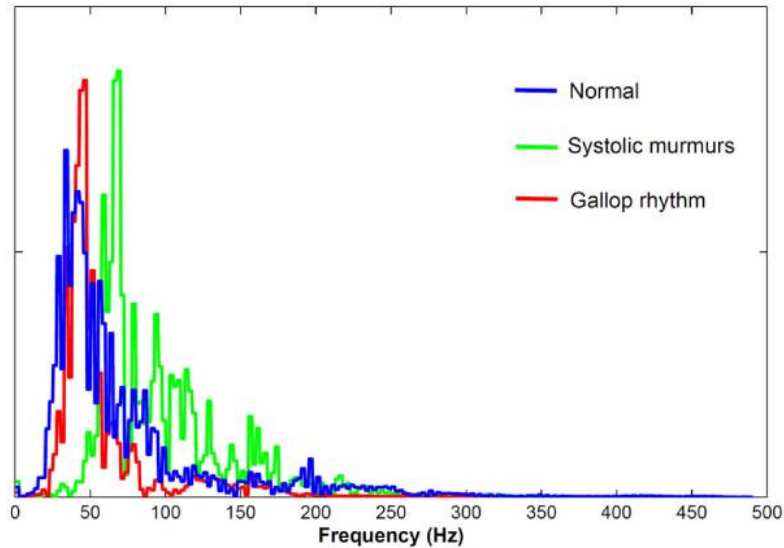

Figure 8. Expected rate of frequency curve for Normal, Systolic, and Gallop (Running) Heartbeats. (Note: the high curve around 20-75 Hz is the most common heartbeat frequency in all cases)

[12]

To minimize the background noise that the microphone will pick up, the tests will take place in quiet areas where high frequency noise can be kept at a minimum. When the test is running, movement of the microphone will be kept at a minimum in order to keep a close distance to the internal sounds of the chest and neck.

#### *Data Testing*

The accuracy of the data gathered with the prototype will be determined by comparing the calculated blood pressure from the headphones with the blood pressure found by using a blood pressure cuff similar to those used by physicians.

#### *LED Arduino Circuit Testing*

The accuracy of using a LED sensor instead of connecting to a smart watch will need to be tested in order to make sure it is suitable for other testing purposes. The method of data collection is similar to the majority of smart watches with heart rate capability, so it is expected to see comparable results in beats per minute from each method of data collection.



## VI. Results

The data from the testing will be analyzed by firstly collecting baseline data utilizing instruments such as a stethoscope and a blood pressure cuff. The testing data can be statistically tested against the baseline data allowing for standard deviation, ANOVA, and variance calculations to determine the best performing setup and equipment for the proto-type.

### *LED Arduino Circuit Results*

Comparison of beats in one minute from the Arduino circuit (Figure 9) to beats measured by the Powr Labs heart rate monitor provided the data shown in Figure 10 provided the following results.

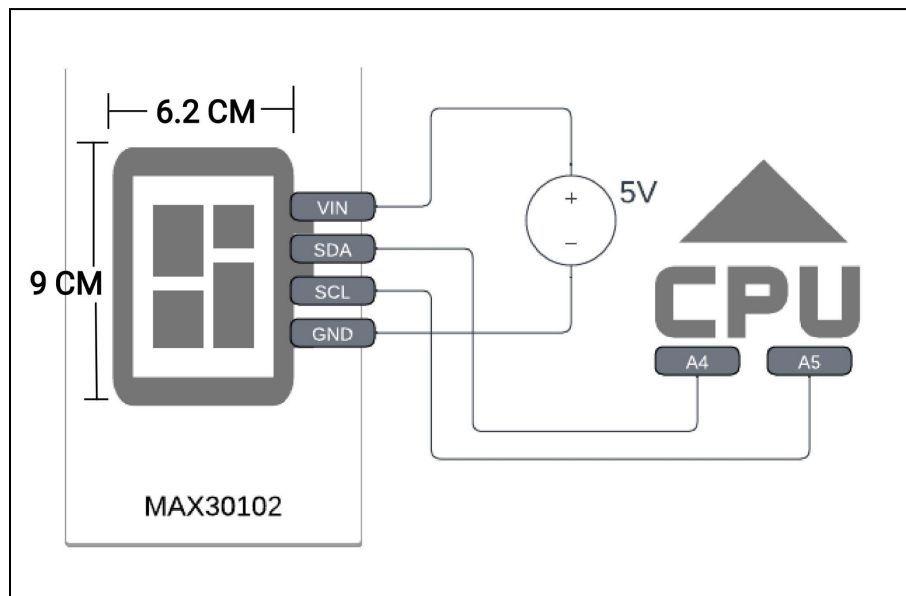

*Figure 9. Arduino Circuit of Heart Rate Monitor*

Not shown is the circuit for code from appendix C that adds another loop on the arduino going from pin 7, through a LED and a resistor to the ground.

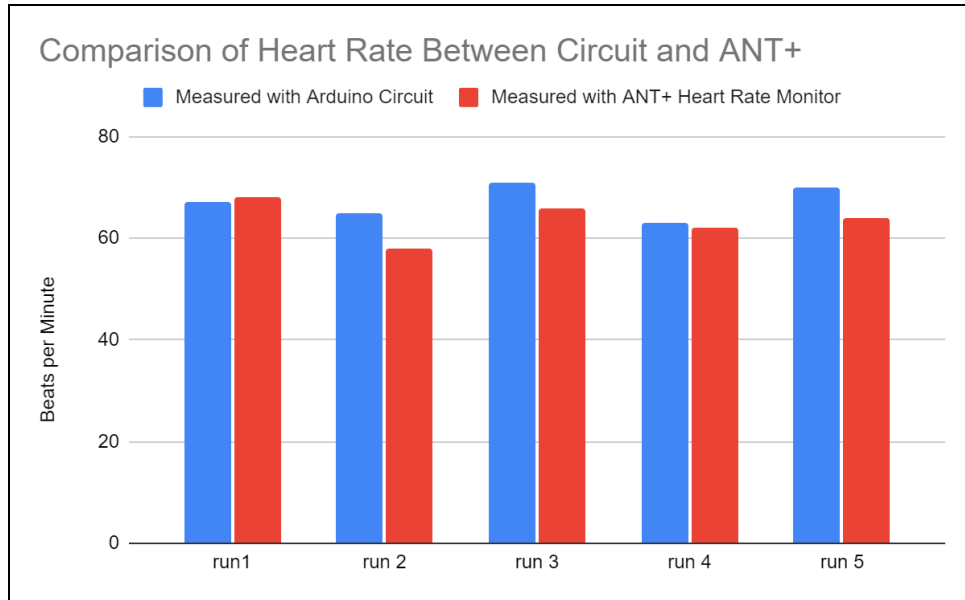

Figure 10. Comparison of Heart Rate Between Circuit and ANT+

The circuit had a mean of 67.2 BPM (beats per minute) over the 5 trials with a standard deviation of 3.35 BPM, while the Powr Labs heart rate monitor had an average BPM of 63.6 and a standard deviation of 3.85 BPM. Both of these results are within reasonable error given the method of collection, however some error may have occurred due to inconsistent pressure of the sensor area with the arduino circuit.

Over the course of one min	Beats from circuit	Beats from ANT+ Heart Rate Monitor
run1	67	68
run 2	65	58
run 3	71	66
run 4	63	62
run 5	70	64
mean	67.2	63.6
Standard Dev	3.35	3.85
Standard Error of the Mean	1.5	1.72
N	5	5

t	1.5787	
Degrees of freedom	8	
standard error of difference	2.28	

Table 2: Comparison of Heart Rate Between Circuit and ANT+ Results

Table 2 shows the data gathered from comparison of heart rate between the circuit shown in Figure 9 and the Powr Labs heart rate monitor. Including the results from an unpaired t test result. The standard error of the mean was slightly higher 1.72 from the heart rate monitor over 1.5 from the circuit. Each had 5 runs. The t value was relatively small meaning that the groups had similar results, however due to the small sample size, larger testing should be completed for more accurate results. The results showed 8 degrees of freedom.

## VII. Discussion

### *LED Arduino Circuit Discussion*

The fabricated arduino circuit shown in Figure 9 based on the results from Table 2 show that this is a reasonable alternative to use for testing instead of integration with an on the market smart watch running ANT+. Results from using the heart rate monitor circuit (Figure 9) could be improved by fabricating a way to more securely attach the sensor to the user. From physical use of watching when the circuit depicted a beat and when beats were felt by placing the fingers over the arteries it was obvious that the circuit sometimes misses beats. This could be fixed in a final product by having values of PTT that are approximately double or more that of recent measurements to be ignored. It was also concluded that for the sake of testing it is reasonable to use a LED heart rate monitor to represent a typical smart watch. Having connectivity with smart watches to receive heart rate data is beyond the scope of this project as it is more of an advanced programming project than a BME project.

This circuit, without a protective casing is not prepared for public use of the device. Having exposed wires that are prone to disconnecting sometimes leads to connecting them in the wrong way, causing the board to short circuit and overheat. Additionally most sensors used in smartwatches have a layer of transparent material between the sensor and the wrist for comfort, applying this sensor directly to the skin can cause discomfort in the user which is not ideal for extended use. If this were to be used for extended testing or in a final product the above mentioned issues must be addressed.

Some error in the results found in Table 2 could have come from inconsistent pressure from both devices and human error in starting each sensor at the same time. Like mentioned in the introduction, smart watch LED sensors are inconsistent already, so it would be recommended that in a final product where PTT is measured to automatically search for values that are over double the expected value coming from the sensor missing a beat to be ignored.

### *Microphone Testing Results*

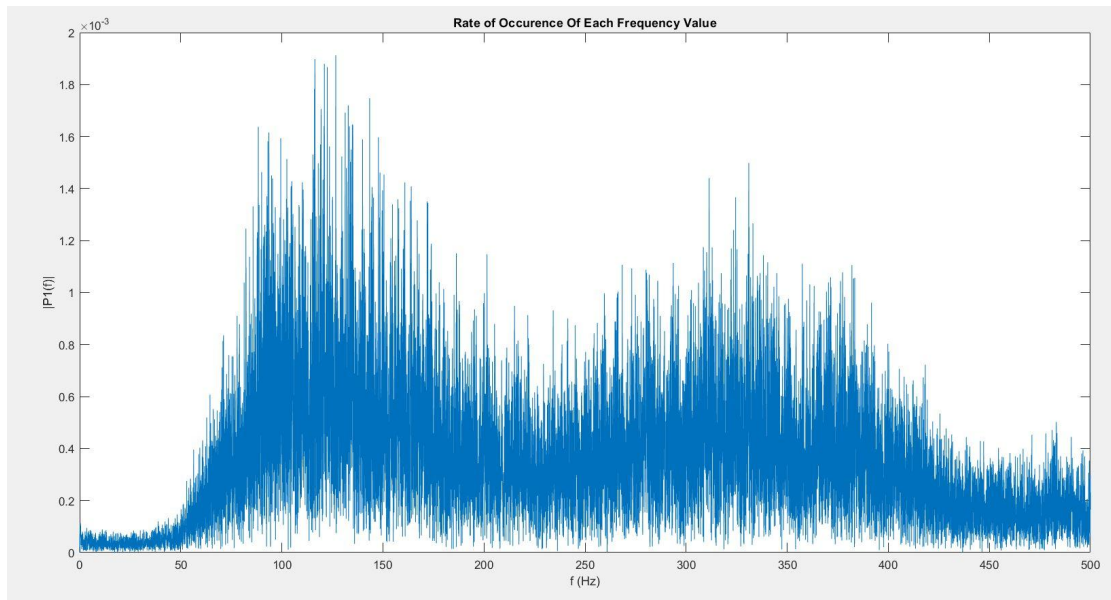

*Figure 11. Microphone Fast Fourier Transformation Results on Chest*

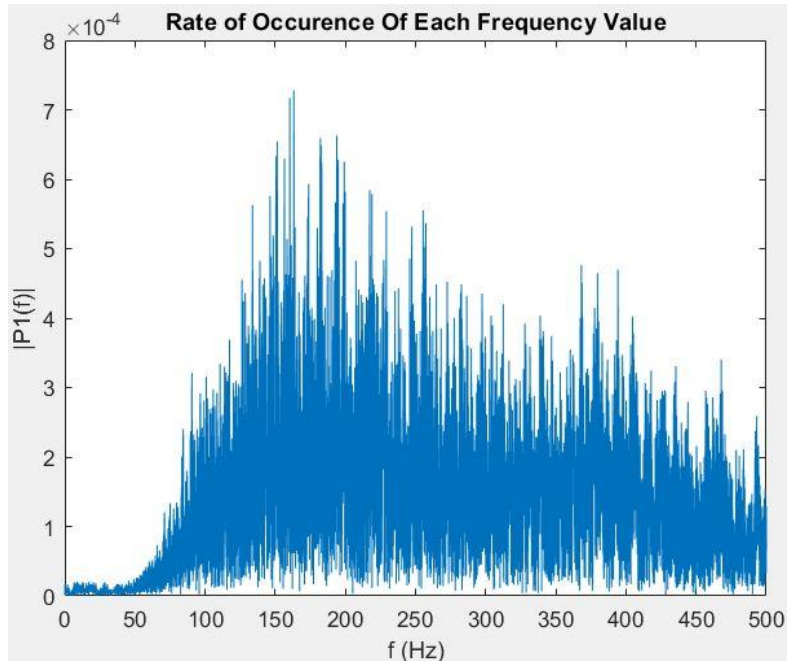

Figure 12. Microphone Fast Fourier Transformation Results on Neck

Figures 11 and 12 showcase the results for the microphone testing on the chest and neck respectively. The null hypothesis for this experiment was that the microphone would not be capable of properly listening to and recording the heartbeat frequency accurately for further design analysis. What can be seen on the ideal curve (Figure 8) is that the most common rate for the three heartbeat types (normal, systolic murmurs, and gallop/running rhythm) have a common frequency of about 20 to 75Hz. However, what can be seen on the chest and neck recording is the actual outputs had the highest frequency occurrences around 75 to 150Hz. Having the commonality of the frequency magnitudes at the higher frequencies is the result of the microphone itself not being as sensitive to lower frequency sizes that would be common for a heartbeat. This is problematic to the design of the headphones as the microphone test fails to reject the null hypothesis indicating it is incapable of accurately recording Pulse Transit Time as it cannot accurately gauge the starting point of the heart's palpitations.

In order to produce more accurate results, it is recommended that a lower frequency microphone would be capable of providing more accurate results as it would prioritize the intended lower frequencies of 20-75 Hz while cutting off the higher, unnecessary background frequencies.

## **VIII. Conclusion**

The client wants a device that will be able to be paired with a smartwatch in order to estimate blood pressure from an auditory input. This device should add minimal weight to a traditional style of headphones, make accurate measurements, be able to be in use over extended periods, and be comfortable for the user. The team plans to propose a design that will prove this idea possible and refine the design in order to make it as accurate as possible. This device also should pair with an app or program that can display and record a record of blood pressure over time. In the future it is planned to pair the design with a rudimentary program that can display the results that would be able to be refined into a more polished product later.

In testing it was found that even when testing in quiet environments, the microphone was not sensitive enough to low-frequency sounds such as the heartbeat. As shown in figure 6, the most common frequency of heartbeats is around 20-75 Hz. However, figures 8 and 9 show that, during testing, the microphone was picking up the majority of sounds around the 75-150 Hz range, with almost nothing comparatively in the 20-75 Hz range. Due to this, future work should prioritize finding a microphone that is more responsive to low frequencies.

The arduino circuit testing revealed that using the circuit to measure heart rate would be an accurate substitution for an on-the-market smartwatch such as the Powr Labs heart rate monitor. One problem that was consistently run into, however, was that the circuit seemed to occasionally miss heartbeats. It was concluded that this was due to unstable pressure of the sensor against the skin. As such, future work should design a way to maintain consistent, yet comfortable, contact between the sensor and the user's wrist.

## **IX. References**

[1]“Blood pressure up? covid-19 pandemic could be to blame,” *National Heart Lung and Blood*

*Institute*, 01-Feb-2022. [Online]. Available:

<https://www.nhlbi.nih.gov/news/2022/blood-pressure-covid-19-pandemic-could-be-blame#:~:text=The%20study%20found%20that%20the,bottom%20number%20%E2%80%93%20also%20rose%20slightly.> [Accessed: 13-Dec-2022].

[2] E. J. Shiffer, “How accurate is the Apple Watch's heart rate monitor for detecting afib? it can't replace medical-grade devices,” *Insider*, 03-Mar-2020. [Online]. Available:

<https://www.insider.com/guides/health/fitness/how-accurate-is-apple-watch-heart-rate#:~:text=The%20Apple%20Watch%20heart%20rate%20monitor%20may%20be%20accurate%20for,rate%20monitor%20is%20most%20useful.>

[3] “Understanding blood pressure readings,” *www.heart.org*, 31-Oct-2022. [Online]. Available: <https://www.heart.org/en/health-topics/high-blood-pressure/understanding-blood-pressure-readings>. [Accessed: 12-Dec-2022].

[4] “Facts about hypertension,” *Centers for Disease Control and Prevention*, 12-Jul-2022. [Online]. Available: <https://www.cdc.gov/bloodpressure/facts.htm>. [Accessed: 02-Sep-2022].

[5] J. M. J. Huttunen, L. Kärkkäinen, and H. Lindholm, “Pulse transit time estimation of aortic pulse wave velocity and blood pressure using machine learning and simulated training data,” *PLoS Comput Biol*, vol. 15, no. 8, p. e1007259, Aug. 2019, doi: 10.1371/journal.pcbi.1007259.

[6] “Jeffrey Edward Koziol ophthalmologist Arlington Heights, il medicinenet,” *MedicineNet*. [Online]. Available: [https://www.medicinenet.com/doctors/ba256dba-35fd-4808-b16d-3bb53767273b/jeffrey-koziol/arlington-heights-il\\_doctor.htm#location](https://www.medicinenet.com/doctors/ba256dba-35fd-4808-b16d-3bb53767273b/jeffrey-koziol/arlington-heights-il_doctor.htm#location). [Accessed: 11-Oct-2022].

[7] J. T. Kare, L. McKnight, and L. Wood, “(72) Inventors: Roderick A. Hyde, Redmond, WA (US);,” p. 41.

[8] “High blood pressure symptoms and causes,” *Centers for Disease Control and Prevention*, 18-May-2021. [Online]. Available: <https://www.cdc.gov/bloodpressure/about.htm>. [Accessed: 19-Sep-2022].

[9] “Safe Listening Devices and Systems.” World Health Organization and International Telecommunication Union, Geneva, 2019. [Accessed: 23-Sep-2022].

[10] “What is ABS plastic?,” *TechTalk Blog*, 07-Jan-2021. [Online]. Available: <https://www.polycase.com/techtalk/materials/abs-plastic.html#:~:text=ABS%20plastic%20is%20also%20one,close%20eye%20on%20material%20costs.> [Accessed: 11-Oct-2022].

[11] N. Söderquist, “TPU – thermoplastic polyurethane,” *BIBS*, 26-Oct-2022. [Online].

Available:

<https://bibsworld.com/en-us/blogs/guides/tpu-thermoplastic-polyurethane#:~:text=TPU%20stands%20for%20'Thermoplastic%20Polyurethane,is%20extremely%20durable%20and%20strong.>  
[Accessed: 12-Dec-2022].

[12]F. Arvin, S. Doraisamy, and E. Safar Khorasani, “Frequency shifting approach towards textual transcription of Heartbeat sounds,” *Biological Procedures Online*, vol. 13, no. 1, 2011.

## **X. Appendix**

### *Appendix A: Product Design Specifications (PDS)*

#### **Problem Statement:**

The team has been tasked by the client to design and develop headphones to record a cardiac pulse signal and pair this with a smart watch to measure PTT and PWV. The design of the headphones should be small and portable with a microphone that would be attached instead of a speaker. A bluetooth link to the user’s watch and phone with the headphones will be required. Both the headphone and the user’s watch will create a pulse that should thus measure the Pulse Transit Time and Pulse Wave Velocity of the body. This data will be recorded and shown on an app that can be accessed by the user on their phone or smart watch. The design of the headphones should be similar to that of Apple airpods and should work with ios systems.

#### **Function:**

Heart disease and high blood pressure are a rising phenomenon that has been affecting the U.S. The need to track and monitor such issues has thus become a much more important goal for many to ensure their cardio health is properly monitored. This device will cover such issues by utilizing a highly receptive microphone that is attached to the headphones that will be capable of listening and recording the rate of the pulse. The headphones will be paired with a smartwatch via bluetooth and will track the pulse rate from the wrist node of the artery to the arterial node the headphones are listening to and thus be capable of calculating and recording the Pulse Transit Time (PTT) and Pulse Wave Velocity (PWV). An app will also be provided where the recorded data will be stored and showcased to the user in an informative and graphical manner.

#### **Client Requirements:**

- The device must be able to connect via bluetooth to phone
  - Headphones should be linked to an app
  - Data recording should be continuous and stored on the app
- Headphones should be able to work like regular headphones (i.e. able to play music)



- Headphones and accompanying devices should be capable of gathering and calculating Pulse Wave Velocity (PWV) and Pulse Transit Time (PTT)
- App should be capable of displaying user's cardio health and statistics

## Design Requirements:

### 1. Physical and Operational Characteristics

#### a. *Performance Requirements:*

- i. The device should be able to function for everyday use.
- ii. Block out noise so that the heart measurements are not tampered with.

#### b. *Safety:*

- i. Ensure that material will not be invasive to the ear.
- ii. The audio levels (decibels) should be within range of comparable items on the market.

#### c. *Accuracy and Reliability:*

- i. It is expected that the blood pressure measurements from the headphones should mirror that from a typical blood pressure cuff device.
  1. For healthy individuals: The diastolic should be within the range of 50-80. The systolic should be within the range of 100-120[1].
  2. For individuals with heart problems, these values should be either significantly higher or lower than these ranges.

#### d. *Life in Service:*

- i. Lifespan is approximately two years.

#### e. *Operating Environment:*

- i. The headphones will be exposed to a variety of conditions.
  1. The device will pick up measurements under heavy background noise.
  2. When used outside, the device will withstand environmental conditions such as severe humidity.

#### f. *Ergonomics:*

- i. The headphones should be portable and easy to wear for the user with little to no weight difference to regular headphones.
  1. Exercise and most daily activities with this device should feel comfortable.

#### g. *Size:*

- i. The headphones should not be too bulky on the head/ear.
- ii. The size will be similar to that of an average headphone.

#### h. *Weight:*

- i. Mass and weight of the smart headphones shouldn't exceed 20% more than the mass and weight of normal air-pods or headphones

1. A singular air-pod weighs 4.00 grams
2. An average headphone weighs about 0.65 lbs

*i. Materials:*

- i. The material should be smooth for the inner ear. The materials that can be used for this include several types of plastic, rubber, and bendable metals
- ii. To detect signals, a microphone and/or an LED will be used.

**2. Production Characteristics**

*a. Target Product Cost:*

- i. The research, development, and initial production should be within a \$5,000 budget.

*b. Quantity:*

- i. One set of headphones will be created for this project.

**3. Miscellaneous**

*a. Standards and Specifications:*

- i. A user must not exceed over 80dB of sound over 48 hours[3]

*b. Customer:*

- i. Adults from the age of 40 to 80 years old

*c. Patient Related Concerns:*

- i. The user's data will be stored on the app.

*d. Competition:*

- i. No known competing designs found.

*Appendix B: Final Expenses and Materials List*

Item	Descripti	Manufac	Part	Date	QTY	Cost	Total	Link
------	-----------	---------	------	------	-----	------	-------	------

	on	urer	Number			Each		
<b>Category 1 - Circuit Materials</b>								
ANT+ receiver	Allows for data collection from most fitness marketed smart watches	CooSpo	N/A	10/20/2022	1	\$9.99	\$9.99	<a href="https://www.amazon.com/CooSpo-Cycle-Ops-Train-Road-Extension-Included/dp/B07CB4328P/ref=sr_1_1_sspa?keywords=ant%2Bdongle&amp;qid=1663620132&amp;sr=8-1-spons&amp;th=1">https://www.amazon.com/CooSpo-Cycle-Ops-Train-Road-Extension-Included/dp/B07CB4328P/ref=sr_1_1_sspa?keywords=ant%2Bdongle&amp;qid=1663620132&amp;sr=8-1-spons&amp;th=1</a>
MAX9814 Microphone	Microphone design #1 for testing for heart signal pickup.	Dorhea	MAX9814	10/20/2022	10	\$2.50	\$24.99	<a href="https://www.amazon.com/DORHEA-Microphone-Amplifier-Electret-Programmable/dp/B09N92M6V5">https://www.amazon.com/DORHEA-Microphone-Amplifier-Electret-Programmable/dp/B09N92M6V5</a>
Microphone	Microphone design #2 for testing for heart signal pickup.	CUI Devices	CMA-4544PF-W	10/20/2022	2	\$0.76	\$1.52	<a href="https://www.arrow.com/en/products/cma-4544pf-w/cui-devices?gclid=Cj0KCOjwhY-aBhCUARIsALNIC07JSq7yDiOaUO1hdJ8">https://www.arrow.com/en/products/cma-4544pf-w/cui-devices?gclid=Cj0KCOjwhY-aBhCUARIsALNIC07JSq7yDiOaUO1hdJ8</a>

								<a href="https://www.amazon.com/PoP-voice-Microphone-Omnidirectional-Smartphones/dp/B075VQ7VG7/ref=asc_df_B075VQ7VG7/?tag=hyprod-20&amp;linkCode=df0&amp;hvadid=312118595187&amp;hvpos=&amp;hvnetw=&amp;hvrnd=17228464567582278820&amp;hvptwo=&amp;hvqmt=&amp;hvdev=c&amp;hvdcmdl=&amp;hvlocint=&amp;hvlocphy=9018948&amp;hvtargid=pla-524514360">x6vj20FWGdvyH0Y CJ_AMp7 ItenRbUp 6mk-N8a Ave_EAL w_wcB&amp; gclsrc=aw .ds</a>
Microphone for stethoscope	Will use the stethoscope to convert the physical sound into a digital aux output that can be used.	PoP Voice	PPV041	11/19/2022	1	\$10.99	\$10.99	<a href="https://www.amazon.com/PoP-voice-Microphone-Omnidirectional-Smartphones/dp/B075VQ7VG7/ref=asc_df_B075VQ7VG7/?tag=hyprod-20&amp;linkCode=df0&amp;hvadid=312118595187&amp;hvpos=&amp;hvnetw=&amp;hvrnd=17228464567582278820&amp;hvptwo=&amp;hvqmt=&amp;hvdev=c&amp;hvdcmdl=&amp;hvlocint=&amp;hvlocphy=9018948&amp;hvtargid=pla-524514360">https://www.amazon.com/PoP-voice-Microphone-Omnidirectional-Smartphones/dp/B075VQ7VG7/ref=asc_df_B075VQ7VG7/?tag=hyprod-20&amp;linkCode=df0&amp;hvadid=312118595187&amp;hvpos=&amp;hvnetw=&amp;hvrnd=17228464567582278820&amp;hvptwo=&amp;hvqmt=&amp;hvdev=c&amp;hvdcmdl=&amp;hvlocint=&amp;hvlocphy=9018948&amp;hvtargid=pla-524514360</a>

							<a href="#">158&amp;psc=1</a>	
3.5mm Jack	For arduino wiring, it will allow testers to listen directly to the microphone input so it can tell how distorted our input signal is while testing.	Gikfun	AE1223	2	3	\$2.66	\$7.98	<a href="https://www.amazon.com/Gikfun-Breakout-Headphone-Arduino-AE1223/dp/B01KFP0HBG/ref=sr_1_2?keywords=arduino+aux+input&amp;qid=1666032203&amp;qu=eyJxc2MiOiIwLjAwLjwicXNhIjoiMC4wMCIslnFzcCI6IjAuMDAifQ%3D%3D&amp;srefix=arduino+aux%2Caps%2C109&amp;sr=8-2">https://www.amazon.com/Gikfun-Breakout-Headphone-Arduino-AE1223/dp/B01KFP0HBG/ref=sr_1_2?keywords=arduino+aux+input&amp;qid=1666032203&amp;qu=eyJxc2MiOiIwLjAwLjwicXNhIjoiMC4wMCIslnFzcCI6IjAuMDAifQ%3D%3D&amp;srefix=arduino+aux%2Caps%2C109&amp;sr=8-2</a>
Heart Rate Sensor	Will allow it to wire it in such a way that it can collect heart rate, pulse and blood oxygen data for testing.	AITRIP	MAX3102	2	2	\$4.65	\$9.29	<a href="https://www.amazon.com/AITRIP-MAX30102-Detection-Concentration-Arduino/dp/B08NFY97SC/ref=sr_1_2?keywords=arduino">https://www.amazon.com/AITRIP-MAX30102-Detection-Concentration-Arduino/dp/B08NFY97SC/ref=sr_1_2?keywords=arduino</a>

								<a href="#">+heart+rate+sensor&amp;qid=1666042540&amp;qu=eyJxc2MiOiIzLjcyIiwicXNhIjoIMy40NiIsInFzcCI6IjMuNTIifQ%3D%3D&amp;sprefix=arduino+heart+%2Caps%2C126&amp;sr=8-2</a>
Contact Microphone	Designed for picking up audio from acoustic instruments it will be tested to see how well it may be able to pick up heart rate when placed on the neck.	traderplus	4334251431	11/19/2022	1	\$14.69	\$14.69	<a href="https://www.amazon.com/TradePlus-Contact-Microphone-Mandolin-Ukulele/dp/B07795XHLH/ref=sr_1_1_sspa?crd=3QNHK80MU6YOO&amp;keywords=contact+microphone&amp;qid=1668463835&amp;sprefix=contact%2520microphone%2Caps%2C124&amp;sr=8-1-spons&amp;">https://www.amazon.com/TradePlus-Contact-Microphone-Mandolin-Ukulele/dp/B07795XHLH/ref=sr_1_1_sspa?crd=3QNHK80MU6YOO&amp;keywords=contact+microphone&amp;qid=1668463835&amp;sprefix=contact%2520microphone%2Caps%2C124&amp;sr=8-1-spons&amp;</a>

								<a href="#">sp_csd=d2lkZ2V0TmFtZT1zcF9hdGY&amp;pse=1</a>
<b>Category 2 - Headphone Materials</b>								
3D Printed Parts	Includes the frame, speaker housings, speaker covers	N/A	N/A	10/24/2022	5	\$45.00	\$50.00	<a href="#">N/A</a>
3D Printed Parts #2	Includes the frame, speaker housings, speaker covers, adjustable wrenches, and pins	Makerspace	N/A	10/31/2022	1	\$27.50	\$27.50	<a href="#">N/A</a>
Speaker Cushions	Professional Replacement Earpads Cushions for Bose QuietComfort	SoloWit			1	\$19.95	\$19.95	<a href="https://www.amazon.com/Professional-Bose-QC35-Cushions-Replacement/dp/B07TZJ1CMC/ref=sr_1_7?c=ts&amp;keywords=Headphone+Earpads&amp;qid=1666042180&amp;qu=eyJxc2MiOiI2LjMzIiwicXNhIjoibWZlc2E4MzIiLCJ1aWQiOiJlIiwiaW50IjoiMSJ9">https://www.amazon.com/Professional-Bose-QC35-Cushions-Replacement/dp/B07TZJ1CMC/ref=sr_1_7?c=ts&amp;keywords=Headphone+Earpads&amp;qid=1666042180&amp;qu=eyJxc2MiOiI2LjMzIiwicXNhIjoibWZlc2E4MzIiLCJ1aWQiOiJlIiwiaW50IjoiMSJ9</a>

								<a href="#">kifQ%3D%3D&amp;s=electronics&amp;sr=1-7&amp;ts_id=13880181</a>
<b>Category 3 - Testing Materials</b>								
Heart Rate Monitor	ANT Compatible so should be able to be used for gathering the general "smart watch" signal from this.	POWR LABS	N/A`	10/20/2022	1	\$59.99	\$59.99	<a href="https://www.amazon.com/Powr-Labs-Bluetooth-Monitor-Armband/dp/B088RMK1GX/ref=sr_1_3?crid=SC5GCSXI6W87&amp;keywords=ant%2B+watch&amp;qid=1663624060&amp;sprefix=ant%2B+watch%2Caps%2C94&amp;sr=8-3">https://www.amazon.com/Powr-Labs-Bluetooth-Monitor-Armband/dp/B088RMK1GX/ref=sr_1_3?crid=SC5GCSXI6W87&amp;keywords=ant%2B+watch&amp;qid=1663624060&amp;sprefix=ant%2B+watch%2Caps%2C94&amp;sr=8-3</a>
Wireless Blood Pressure Cuff	This will allow the team to compare to a baseline of what our blood pressure should be within a +- 5% accuracy. This also allows it	A&D Medical	UA-1200 BLE	10/20/2022	1	\$99.99	\$99.99	<a href="https://medicalonline.com/product/ultraconnect-premium-wireless-blood-pressure-monitor-ua-1200ble/#tab-id-4">https://medicalonline.com/product/ultraconnect-premium-wireless-blood-pressure-monitor-ua-1200ble/#tab-id-4</a>



	to store data over long periods of time and can export data directly to excel for comparison to what data to collect from the design.							
Stethoscope	For testing a proven way to pick up the heart sound by converting it to a digital output for our testing.	BP MEDICAL SUPPLIES	\$143,212.00	11/18/2022	\$1.00	\$6.95	\$6.95	<a href="https://www.amazon.com/Everdixie-Dual-Head-Stethoscope-Pink/dp/B000FSIV6M?th=1">https://www.amazon.com/Everdixie-Dual-Head-Stethoscope-Pink/dp/B000FSIV6M?th=1</a>
						<b>TOTAL:</b>	<b>\$343.83</b>	

*Appendix C: Final Arduino HRM Circuit Code*

/\*

- \* -5V = 5V (3.3V is allowed)
- GND = GND
- SDA = A4 (or SDA)
- SCL = A5 (or SCL)
- INT = Not connected

\*/

```
#include <Wire.h>
```

```
#include "MAX30105.h"
```

```
#include "heartRate.h"
```

```

MAX30105 particleSensor;
//MAX30105 particleSensor2;

const byte RATE_SIZE = 4; //Increase this for more averaging. 4 is good.
byte rates[RATE_SIZE]; //Array of heart rates
byte rateSpot = 0;
long lastBeat = 0; //Time at which the last beat occurred

void setup() {
  Serial.begin(115200);
  Serial.println("Initializing...");

  // Initialize sensor
  if (!particleSensor.begin(Wire, I2C_SPEED_FAST)) //Use default I2C port, 400kHz speed
  {
    Serial.println("MAX30105 was not found. Please check wiring/power. ");
    while (1);
  }

  Serial.println("Place your index finger on the sensor with steady pressure.");

  particleSensor.setup(); //Configure sensor with default settings
  particleSensor.setPulseAmplitudeRed(0x0A); //Turn Red LED to low to indicate sensor is
running
  particleSensor.setPulseAmplitudeGreen(0); //Turn off Green LED

  pinMode(7, OUTPUT);
}

void loop() {
  long irValue = particleSensor.getIR();
  //long irValue2 = particleSensor2.getIR();

  if (checkForBeat(irValue) == true)
  {
    digitalWrite(7, LOW);
    Serial.println("beat");
  } else {
    digitalWrite(7, HIGH);
  }
}

```

```
}
}
```

### *Appendix D: Microphone Matlab Testing Code*

```
L= 30*10000; %Recording Length
Fs = 10000; %Sample Rate (Hz)
dev = audiodevinfo;
rec = audiorecorder(Fs, 16, 1, -1); %setting up recorder for audio length, bit
rate, number of channels, and channel ID
disp('start speaking');
recordblocking(rec,L/10000); %Recording begins with type chosen (rec) and
amount of time in seconds
disp('Stop recording');
play(rec);
y = getaudiodata(rec);
figure(1);
plot(y);
x = fft(y); %fast fourier transformation program
P2 = abs(x/L);
P1 = P2(1:L/2+1);
P1(2:end-1) = 2*P1(2:end-1);
f = Fs*(0:(L/2))/L;
figure(2);
plot(f, P1);
title("Rate of Occurence Of Each Frequency Value");
xlabel("f (Hz)"); %frequency magnitude in Hz
ylabel("|P1(f)|"); %relative rate of frequency occurrences (unitless)
xlim([0,500]);
```

### *Appendix E: Testing Protocols*

#### Microphone:

1. Place microphone up to the user's neck or chest firmly to keep pressure on contact with body to ensure closed audio
2. Begin program (found below) in Matlab
3. Stay quiet when "Recording started" has is shown until "Recording ended" is seen
4. Matlab will calculate the results and output the testing graph data for the user to see in fast fourier transformation for proper analysis
5. Repeat steps 1-4 on different areas of the body to test for different results

#### Arduino Circuit and Powr Labs:

1. Begin Arduino code from "11/18 Editing Arduino Code" and place sensor on finger with constant pressure, works best with a rubber band.
2. Begin simulation in Antware 2 software, be sure to use settings found in "10/31 ANT+ HRM Pairing", tighten heart rate monitor with a comfortable pressure on forearm or wrist.
3. Begin timer for 60 seconds, once it is complete record total beats sensed, not average beats per minute.
4. Repeat 1-3 for at least 5 trials.