

# BME Design-Fall 2023 - Zac Mayhew Complete Notebook

PDF Version generated by

Megan Finell

on

Dec 13, 2023 @09:13 PM CST

## Table of Contents

Project Information	2
Team contact Information	2
Project description	3
Team activities	4
Client Meetings	4
2023/9/14 - Client Meeting 1	4
2023/10/10 - Client Meeting 2	8
2023/11/12 - Client Meeting 3	11
Advisor Meetings	14
2023/9/22 Advisor Meeting 1	14
2023/09/29 Advisor Meeting 2	17
2023/10/20 Advisor Meeting 3	18
2023/11/10 Advisor Meeting	19
2023/12/1 Advisor Meeting	20
Materials and Expenses	21
Material Expenses Table	21
Original Receipts of Purchases	22
Fabrication	24
Final Prototype Fabrication	24
Testing and Results	27
Protocols	27
Show and Tell Survey	27
Preliminary Force Testing Protocol	28
Solidworks Strength Simulation Protocol	31
Experimentation	32
Show and Tell Survey Data	32
Show and Tell Survey Results	35
Preliminary Force Testing Data- Second Prototype	38
Solidworks Strength Simulation results	39
MTS Testing Protocol	43
Meeting Notes	44
2023/9/8 - Team Meeting 1	44
2023/9/22 - Team Meeting 2	46
2023/10/13 - Team Meeting 3	47
2023/10/27 - Team Meeting 4	48
2023/10/31- TEAM lab consultation	49
2023/11/10 - Team Meeting 5	52
Annika Rossebo	55
Research Notes	55
Biology and Physiology	55
10/27/23 Skin Mimetics for Testing	55
Competing Designs	58
Rusch QuickTrach Cricothyroidotomy Kit	58
STATForce Adult Deluxe and Pediatric Field Cric Kit	59
The Quick Fix Adult Cric Kit and The Quick Fix Jr.	60
US Patent US4677978A- Emergency Cricothyrotomy System and Cricothyrotomy Kit	61

US Patent US4438768A- Emergency Cricothyroidotomy Instrument	66
US Patent US4291690A- Means for Performing an Emergency Cricothyrotomy	67
Ethics	71
10/12/23 Good Samaritan Law	71
Design Ideas	72
9/27/23 Idea 1	72
9/27/23 Idea 2	74
9/27/23 Idea 3	77
10/12/23 Design/Manual Considerations	80
10/12/23 Design Interface with BVM	81
Tong Lecture 11/10	82
Katerina Smereka	83
Research Notes	83
PDS Research	83
9/20/2023--Code of Federal Regulations for Anesthesiology Devices	83
9/20/2023--Code of Federal Regulations for Anesthesiology Devices, Needles	84
9/20/2023--Code of Federal Regulations for Otolaryngeal Devices	85
9/20/2023--Surgical Anatomy of Cricothyroid Membrane w Reference	86
9/20/2023--Cricothyroidotomy	87
9/20/2023--Prehospital Trauma Scene and Transport Times	88
Biology and Physiology	89
2023/9/10--Ultrasound for airway management: An evidence-based review for the emergency clinician	89
2023/9/10--Retention of emergency cricothyroid skills: A multicenter randomized controlled trial	93
2023/9/10--Cricothyroidotomy-The Emergency Surgical Airway	95
Preliminary Report Research	98
10/10/2023--Biocompatible Plastics in the Medical Field	98
10/10/2023--PVC Properties	99
10/10/2023--Gastric Perforation	100
research 6	101
10/10/2023--Study of Survival Rate After CPR in Hospitals	102
10/10/2023--Accuracy of indentifying the cricothyroid membrane by anesthesia trainees	103
Mathematical Backing of Device Sizing	104
11/7/2023-It's in the Bag:Tidal Volumes of BVM	104
11/7/2023--EMS Pocket Mask	105
11/7/2023--LSP Gooseneck BVM	109
11/7/2023-BVM patent	110
11/7/2023-CPAP Mask valve	111
Design Ideas	112
The Device	112
11/7/2023--Updated Hole Puncher Design	112
11/7/2023--Mathematically Calculating Device Air Velocity	115
11/7/2023--Mathematically Calculating Device Size	116
9/26/2023--The Japanese Soda Handle	117
9/26/2023--The Tampon	119
The Handle	122
11/9/2023--Overall Apperance,	122
11/9/2023--Connection of Handle to Device	126
Holder For MTS Machine	130
12/1/2023--Holder for MTS	130
Testing	131
10/24/2023--Testing Protocol, Skin	131
10/27/2023--Testing Protocol, Force	132
10/31/2023--Show and Tell Survey	133
10/27/2023--Testing Protocol, Air Velocity	134
Mateo Silver	138
Research Notes	138
Biology and Physiology	138
2023/9/14 - Initial Research	138
2023/9/14 - PDS Research	139
2023/9/25 - Ideas for Device Testing	142
Competing Designs	143

2023/10/19 - Competing Design Quicktrach	144
2023/10/19 - Competing Design LifeStat	147
2023/10/19 - Competing Device LifeStat Patent	150
Manufacturing	153
2023/10/19 - Biocompatible materials	153
2023/10/19 - Makerspace/TEAM Lab Resources	154
2023/10/25 - Fabrication Research	155
2023/10/25 - Preliminary Fabrication Protocol	158
2023/11/22 - Fabrication Process	162
2023/12/10 - Final Fabrication Protocol	168
Testing/Usage	174
2023/11/9 - Device Instructions v1	174
Design Ideas	175
2023/9/26 - Individual Design #1	175
2023/9/26 - Individual Design #2	176
2023/9/26 - Individual Design #3	177
Training Documentation	178
2023/10/19 - Biosafety and Chemical Training	178
2023/10/19 - Green Permit Training	179
2023/11/10 - Tong Lecture Notes	180
Outreach Project	181
2023/12/13 - Outreach Proposal Research	181
Intellectual Property	182
2023/12/13 - WARF Innovation Disclosure	182
Megan Finell	183
Research Notes	183
Biology and Physiology	183
2023/09/13 - Anatomy and Physiology of Cricothyroidotomy	183
2023/09/13 - Complications of Cricothyroidotomy	186
2023/10/19 - Tracheal Anatomy	187
2023/10/26 - Cartilage notes from BME 615	189
Competing Designs	192
2023/09/26- Surgicric Cricothyroidotomy Device	192
Materials	195
2023/10/12- Plastics with outstanding mechanical properties	195
2023/10/27 - Skin model materials	196
2023/10/27 - Common Metals found in Surgical Instruments	197
Design Ideas	199
2023/09/27- Design 1	199
2023/09/27- Design 2	201
2023/09/27- Design 3	203
2023/12/13- Drawings for Instructions	206
Training Documentation	210
9/26/2023 - Chemistry and Biohazard Safety Training	210
9/26/2022 - Green Permit Training	211
Fabrication/Testing	212
2023/12/13- Fabrication on Lathe	212
2023/12/13- MTS use notes	216
2023/12/13- Pictures from MTS testing	220
Zac Mayhew	224
Research Notes	224
Biology and Physiology	224
2023/9/18 Emergency Airway Research	224
2023/9/18 Choking Background Research	225
2023/9/18 CPR research	226
2023/9/20 Anatomy of Cricothyroid Membrane	227
2023/10/1 EMS Response	228
2023/10/5 BVM adapter size	229
2023/10/9 Cricothyroidotomy Indications/Contraindications	230
2023/10/26 Locating Cricothyroid Membrane notes	231
Design Ideas	232

2023/9/27 Hand Stabber Design .....	233
2023/9/27 Spring Loaded Design .....	234
2023/9/27 Hook Design .....	235
2023/10/4 Hole Puncher SolidWorks V1 .....	236
2023/10/5 Captain Hook SolidWorks .....	237
2023/10/15 Hole Puncher SolidWorks V2 .....	238
2023/10/26 Hole Puncher V3 .....	239
2014/11/03-Entry guidelines .....	242
2014/11/03-Template .....	243



## Team contact Information

Mateo Silver - Sep 08, 2023, 1:23 PM CDT

Last Name	First Name	Role	E-mail	Phone	Office Room/Building
Dr. Suarez-Gonzalez	Darilis	Advisor	dsuarez@wisc.edu		1003 Engineering Centers Building
Markman	Lenard	Client	lenmarkman@gmail.com		
Zac	Mayhew	Leader	zmayhew@wisc.edu	608-669-4433	
Smereka	Katerina	Communicator	ksmereka@wisc.edu	262-832-4740	
Rossebo	Annika	BSAC	rossebo@wisc.edu	920-257-6877	
Silver	Mateo	BWIG	mnsilver@wisc.edu	608-622-5392	
Finell	Megan	BPAG	finell@wisc.edu	262-388-2350	



## Project description

---

John Puccinelli - Aug 14, 2013, 12:01 PM CDT

**Course Number:**

**Project Name:**

**Short Name:**

**Project description/problem statement:**

**About the client:**



## 2023/9/14 - Client Meeting 1

---

**Title:** Client Meeting 1

**Date:** 9/14/2023

**Content by:** Mateo

**Present:** Megan, Mateo, Annika

**Goals:** Address questions we have about the device and our client's goals

**Content:**

**Questions to ask the client:**

1. Do we have to worry about local anesthesia to apply for the device?
2. Who will use the device? The general joe? Or someone who is trained?
3. Size of the device? Is this going to be stored in a first aid kit?
4. How far should the device puncture?
5. What materials and supplies does our client have for testing purposes?
6. What is our budget?
7. Is this going to be designed particularly for kids?
8. What is our client's role at the hospital?
9. Should this device be single use?
10. How does this compare to current devices on the market? Where is the novelty?
11. Why does the market need this type of device?
12. Is this only used in emergency situations?
13. Will this be used in the hospital or in the field?
14. Do you only have 'one shot' to use this device?
15. Have you worked with BME design students before?
16. Are there any resources that you puke be particularly helpful for us to learn about this topic?
17. What is the best way to contact you?
18. Which days/times would be the best for you to meet?

**Client contact information for meeting:**

715-498-1834

Dr. Lenard Markman

**Notes during client meeting:**

Met with client over the phone to answer our questions about the device.

We discussed why each of us were interested in pursuing the device.



**Why is this device important:** There are 5325 deaths each year from choking. It is important to have a device that can be used quickly in emergency situations. The client has personal connections to the issue, and is very invested in solving this problem.

**When would the device be used:** It would be used on an unconscious patient who has a complete airway obstruction. Either from choking or as a result of anaphylaxis. If the obstruction is caused by choking, the heimlich maneuver can be performed first. A complete airway obstruction can be recognized by the inability to speak. Once the airway is obstructed, there are only 3-5 minutes before brain death begins. "If a person isn't breathing, you can't do any more harm."

**Use case of the device:** Ideally the device would be in every first aid/cpr kit (similar to how AEDs are present in buildings), and by members of the public who would like to be prepared. Ideally, the person using the device should have some training in how to use it. Laypeople could potentially use the device, but positioning may be difficult. The device should come with instructions for use. Once the device is placed into the patient, if they are not breathing the person providing care should be able to breathe into the device to provide oxygen to the patient. Once first responders arrive, a bag valve mask could be attached to the device for easier use.

**Dr. Markman's Prototype:** Dr. Markman carries a prototype of the device wherever he goes. It is fashioned from an insulin syringe, with the end carved to a point. The text on the syringe reads: "3/10 mL U100 insulin single use only syringe." Our device may be similar in size/scale to this prototype. He carries the device for both spontaneous pneumothorax and cricothyroidotomy purposes.

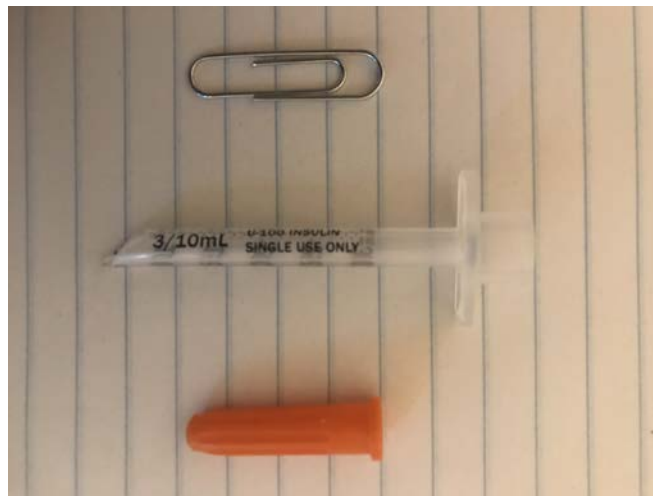

**Device Specifications:** Something easy to use, nothing to think about and go wrong. "Cheaper and easier than what is on the market now. No stylette to remove, nothing to inflate, just the [available] airway."

- The device should be non-ferrous (can go through an airport metal detector), for easy transportation.
  - Client prefers a sharp plastic or ceramic tip vs the metal tips on the market
- The device should be sterile (required if marketed commercially).
- The device should be single use, no requirements of resterilization after usage.
- The piercing end of the device should be sharp.
- The end of the device that sticks out should be adaptable to a bag valve mask and/or facilitate a person breathing into it.
  - At least 500mL of air must be exchanged every 3 seconds
- A marking should be present on the device to indicate if it has been placed at the correct depth. Consider having multiple markings for different patient populations (pediatric vs adult).
- Ideally the device would be inexpensive to manufacture, so it can easily be added to first aid kits.

**Current Devices on the market:** Dr. Markman's concern about the current devices available are increased cost and difficult usage. Most purchasable devices are \$60-80, made of metal/metal tip, awkward/challenging to use, and for use in a controlled environment.

**Budget for device:** Can be discussed later. It seems like there is a good budget for development costs. Manufacturing costs should be kept as low as possible.

**Usage/anatomical information:** First, anatomical landmarks are recognized. The device punctures through the membrane, until a pop is heard. Next, point the device downwards (inferiorly). The device is inserted to a certain depth depending on patient age (pediatric vs adult).

**Client information:** Dr. Markman is located in Amherst, WI (2.5 hour drive from Madison). He has worked with BME design before, on the dissolvable epinephrine tablet project. The best way to get in touch with him is over email. Phone reception is spotty where he lives/works. For a recurring meeting time, tuesdays or thursdays would work best.

**Client personal story:** Dr. Markman graduated from UW Madison as a PA in 1978. After graduation, he worked on a menominee tribal reservation. Came back to Madison working in preventative oncology. Taught emergency medicine course for med school. Went to med school and did his residency in CO. Professionally, he has worked in rural medicine. Worked in Amherst with wife for 25 years. Now retired, but working on epinephrine legislation.

**Client personal connection with device:** Has done an emergency cricothyroidotomy on a dog before, but wants to be completely prepared.

**Potential Legal concerns:** None. The good samaritan law should cover usage, as long as no harm is intended. But in law there are always liability issues.

**Extra information:** In the past a 14 gauge needle has been used in emergency situations. But this diameter may not be big enough to get good enough oxygen exchange. Our device should be wider than 14 gauge.

Crikey tube vs trach tube. A trach is for longer term use.

Naming the device: Emergency cricothyroidotomy device (ECD)

Placement is easy once trained, easier than starting an IV once a landmark is established.

**Aside, law that allows laypeople to carry epinephrine:** A law has passed that allows laypeople to get legally get trained and have permission to carry epinephrine. EMTs can take the course and then be able to teach the course. American red cross course also can give a certificate. Dr. Markman runs a course, which is more hands-on compared to the red cross course.

**Conclusions/action items:**

Establish a reoccurring meeting with Dr. Markman. Follow up with him if we have new questions that come up.



**2023/10/10 - Client Meeting 2**

---

**Title:** Client Meeting 2

**Date:** 10/10/23

**Content by:** Annika

**Present:** Kat, Zac, Mateo, Megan, Annika

**Goals:** Our goal is to run our final design by our client and discuss how to finance the project.

**Content:**

- Client agrees that our proposed design is similar to his prototype
- Design can be used with both right and left handed people
- We can change the dimensions if needed
- Client asked if it will attach to a BVM
  - The answer is yes
- Client wants another hole on the bevel side incase it gets clogged on top
  - As you ventilate, air will be coming out of that little tube
  - Blood or tissue might clog the bevel side
  - On the 10mm side, not the 15mm side
  - Bevel inserting down towards the lungs
  - Need to make sure it wouldn't weaken shaft
  - Multiple holes for increased air exchange?
  - Flow rate equations with air going through small tube
  - Could do one or two extra holes
- Design "looks good" and "non-threatening"
- How will we be financing the project?
  - We could email him what we need and have the client send the packages to us
  - OR we could buy things on our own and have him reimburse him at the end
  - Client is on a tight budget
  - University covered his last team's expenses
  - He said he wants to know what we will be purchasing
- Client agrees with 3D printing
- Mass production: mold fabrication
- \$100 budget for the whole year
  - Client thinks there may be other funding options available
- Client suggests that if we have contacts in the ENT department we should run this design by them
  - They can pick up red flags right away
- Would the device be used by the average joe or by a trained professional? Client answer:
  - Liability wise: trained professional
  - Instructions need to be simple so theoretically anyone could use this
- Does our device meet the requirements in our client's eyes for a tension pneumothorax?
  - 14 gauge needles commonly used
  - Not sure if it hits the depth requirement
  - Maybe if we make our device 2cm instead of 1.5cm it could work for a tension pneumothorax
  - We don't have to make it a tension pneumothorax device
    - If it was dual purpose, that would be great, but not needed
  - Client thinks there are more deaths from choking than tension pneumothorax in the US
- Client will be in Madison on Sunday 10/22 (~3-5pm)

**Conclusions/action items:**

Overall, our client approved of our proposed design. Our client proposed adding a hole to the shaft of the design to increase airflow incase of blood or tissue blockage of the bevel hole. Our team will need to incorporate this hole into our design as well as

decide on final measurements. Our team is also working on the preliminary design report that is due this week. We will discuss the possibility of having a working prototype for our client on 10/22.



## 2023/11/12 - Client Meeting 3

---

**Title:** Client Meeting 3

**Date:** 11/12/23

**Content by:** Mateo

**Present:** Zac, Mateo, Megan

**Goals:** Discussing our current prototype and manufacturing plans with our client.

**Content:**

- Showed client our current prototypes, discussed our previous design ideas
- Client showed us his current prototype
- **Design:**
  1. Client doesn't think a handle is needed, it doesn't take much force to puncture the cricothyroid membrane. His solution is to place his thumb inside the BVM attachment point of the device.
  2. On top of our device being packaged sterilely, the needle should stay relatively clean between opening the package and placing the device, as the user does not come into contact with the needle end of the device
  3. Potential design change, making the BVM attachment piece deeper. This could help facilitate breathing into the device, before a BVM is available.
- **Testing:**
  1. The client believes our current skin model is about same thickness as the skin and the membrane
- **Fabrication:**
  1. The client agrees that fabrication in aluminum would help with the sharpness of the needle and durability of the device. "The sharper the better"
  2. The client raised concerns about higher cost of manufacturing, compared to a polymer, as well as ability to be passed through a metal detector
- **Device Instructions:**
  1. The device should be inserted at angle, tilted backwards towards head, with the beveled end down
  2. Once the membrane is punctured, a "pop" should be heard
  3. Who is our audience, who will be using the device? EMTs, paramedics, doctors
    - The device could be taught alongside Narcan, epinephrine devices, etc.
  4. The client likes the idea of a sheet which could be placed on top of the patient to guide proper placement. However, the anatomy differs between patients, and you wouldn't be able to see landmarks easily
  5. Zac proposed using a QR code with instructions
- **Device Packaging:**
  1. Instructions could be included on top of the sterile packaging, and/or as an additional manual with the device packaging.
  2. Client brought up adding braille to the packaging, consider other populations when designing packaging
  3. Consider transparent package to make device seem more accessible
  4. Needle cap makes the device looks less threatening
- **Long Term Goals:**
  1. Client would like us to submit our idea to WARF at the end of the project
    - Would give us experience with filing paperwork
    - WARF can work out legal details of usage, liability
- **Further research:**
  1. The client has done some research about where in the upper airway choking obstructions occur. Currently he is unsure.
  2. When obstructions occur due to Anaphalxis, 25% of cases are an obstruction of the upper airway, a case where our device could be used

**Conclusions/action items:**

Continue manufacturing device as planned, sending weekly progress reports.





**2023/9/22 Advisor Meeting 1**

---

**Title:** Advisor Meeting 1- 9/22/23

**Date:** 9/22/23

**Content by:** Mateo, Zac, Katerina, Annika, Megan

**Present:** Mateo, Zac, Katerina, Annika, Megan

**Goals:** Our goal is to have a weekly meeting with Dr. Suarez for the first time. We hope to go over our PDS.

**Content:**

PDS feedback from Dr. Suarez

- Need more numerical/qualitative analysis
  - Size of the device
- Kat emailed the client about the size of the incision
  - Our client wants a single puncture device to be used in one fluid motion
  - Need to make sure blood will not occlude device
  - Need to change this on the PDS
- Lightweight- can we get a weight from other market items as a goal for our device?
- No major red flags□

Project overview to Dr. Suarez- including perspective from the client

- Device will be used when heimlich cannot remove airway obstruction
- Client carries this makeshift device on him

General notes

- Challenge- testing the device
  - Option: reaching out to veterinary places on campus to get canine cadaver tissue
  - Client says testing with mannequin is not ideal
  - If we did animal/human testing, we would need an IRB
- Need to go through 2 layers- skin and trachea
  - Research skin models/mimics for testing
  - Tiered testing- skin, then cartilage
  - Search "skin" on design website- mastectomy project, spring 2023
- Project budget
  - Client has not provided a budget yet
  - We need to clarify this with him
  - We can research skin mimics and 3D printing to give the client an estimate of initial expenses
- Fabrication ideas
  - 3D printing
  - Molding? Like on Annika's last project
- Grading
  - Dr. Suarez does all the grading
  - If we are tight on time just let her know- she will determine if it is reasonable
- Notebook checks
  - She will check our notebooks next meeting
  - Each team member will share their own notebook for ~3 minutes
    - Research
    - Design sketches
  - This will take the place of the preliminary notebook check/grade
  - We won't do this every week but will do it often
    - She will give us a week warning

- Level of training for use of the device
  - Do not worry about this for now
- Look into sharp plastic devices for puncturing
  - Ex: puncturing an IV bag
  - Ex: drawing blood on infants
- If we don't get a response from her in a day over email and we need something urgently, reach back out

**Conclusions/action items:**

We will be revising our PDS and submit it this afternoon. Our goals for the weekend are to each create a design idea for the project and have it ready to present to the team by Monday.

**Action items:**

- Each create a design idea
- PDS edits
  - Need a weight
  - Need size of device
  - Need to revise puncture/incision size
  - Submit PDS
- Clarify/solidify budget with client
- Keep individual design notebooks updated for individual presentation next week
- Research sharp plastic devices as ideas for our design
- Complete design matrix



## 2023/09/29 Advisor Meeting 2

---

ANNIKA ROSSEBO - Sep 29, 2023, 1:01 PM CDT

**Title:** Advisor Meeting 2

**Date:** 9/29/23

**Content by:** Annika

**Present:** Mateo, Zac, Annika, Kat, Megan

**Goals:** Our primary goal during this meeting is to go through out individual notebooks to show our progress. If we have time, we will go over our PDS.

**Content:**

- Next week- preliminary presentations in person, in ECB as of now
- Dr Suarez will be at the BMES conference the week after next and will not be checking email/canvas on Wednesday and Thursday of that week
- Dr Suarez wanted us to clarify the portability section of the design matrix
- Individual notebook check scores will be posted on canvas
- We briefly discussed a team bonding activity- six flags? Corn maze?
- Design matrix feedback
  - Harder time visualizing why designs 2 and 3 scored lower for portability
    - We verbally explained our thinking behind this
  - Dr Suarez likes idea 3 because it is similar to an EpiPen. She could most visualize herself using this
    - However, she is aware this design will cost more, which goes against what the client wants
  - She suggested we show our client the designs
  - Suggested that we should look at the materials used for the cheaper market devices to see if we can use that material too

**Conclusions/action items:**

Our preliminary presentations are next week. We will assign each team member some slides and then meet as a team to edit them and practice our presentation. Following that week, our initial design deliverables are due, so we need to focus on all of our goals ahead, not just for this week. This week, we need to reach out to our client and have a conversation about our designs and if he agrees with our top device.



## 2023/10/20 Advisor Meeting 3

---

ANNIKA ROSSEBO - Oct 20, 2023, 1:33 PM CDT

**Title:** 2023/10/20 Advisor Meeting 3

**Date:** 10/20/23

**Content by:** Annika

**Present:** Kat, Zac, Megan, Mateo, Annika

**Goals:** Our goal is to show Dr. Suarez our prototype, discuss our preliminary presentation and report, and discuss next steps for our project.

**Content:**

- something to cover sharp tip so you dont stab yourself
- also need a way to secure it so a single provider can grab a BVM
- notebook check next week
- is there a way to make sure the anatomy is chosen correctly for insertion?
- thinks the testing during show and tell is a good idea
- patch to visualize blood vesseles
- next steps: making instructions
- dr suarez doesnt think this could be used by the average person- she thinks this would be used by a trained professional
- look at standards for current devices- can anyone use it?
- next steps: testing protocols
- next steps: metal construction- controlling sharpness of tip
- research tracheotomy tubes- soft tip
- dr suarez has expired trach tube at home
- talk to the biopsy punch team during show and tell

**Conclusions/action items:**

Next steps for our team include meeting with/at the team lab for metal fabrication, creating testing protocols, and making instructions for use of the device. Our team will also start brainstorming contacts for outreach.



## 2023/11/10 Advisor Meeting

---

ANNIKA ROSSEBO - Nov 16, 2023, 10:03 AM CST

**Title:** Advisor Meeting 11/10

**Date:** 11/10/23

**Content by:** Annika, Megan

**Present:** Annika, Megan, Kat, Zac

**Goals:** Our goal is to update Dr. Suarez on how show and tell went. We also want to discuss plans for fabrication and testing.

**Content:**

- Talked about show and tell feedback
  - Showed her data that mean and median from questions 1-4 was 3 (in the middle)
- Asked about metal prototype
  - We 3d printed to start
- How to make the device sharp enough
  - No specific feedback during show and tell
  - We talked with the kidney biopsy group- can share ideas
- Are we starting testing?
  - Yes, wanting to start on it soon
  - Didn't want to break prototype before client meeting this Sunday (11/12)
  - She suggested solidworks testing
    - LinkedIn learning tutorials? License through UW
    - <https://it.wisc.edu/services/online-training-linkedin-learning/>
- Budget limit
  - She suggested looking into the Makerspace, but they may only have sheet metal
  - Look into how expensive the materials are looking and bring that up to Dr. P
  - About \$100, when ordering parts we have to consider the budget (that we currently have)

**Conclusions/action items:**

Dr. Suarez suggested that we look into Solidworks testing for our prototype. She also provided a link to LinkedIn learning and said that UW has an account where we may be able to find Solidworks testing tutorials. She said she envisioned us doing some preliminary testing this semester, but probably doing the bulk of the testing next semester so that we can focus on fabricating a solid prototype this semester. She is not sure if she will be able to meet next week, but will update us.



## 2023/12/1 Advisor Meeting

---

Zac Mayhew - Dec 13, 2023, 2:10 PM CST

**Title:** Advisor Meeting Notes

**Date:** 12/1/2023

**Content by:**

**Present:** Whole group

**Goals:** The goal of this document is to outline the advice from Dr. Suarez during our advisor meeting.

**Content:**

- Prototype is light and sharp
- We got pig trachea
- Rudimentary force testing- sources of error
- MTS testing consultation with Dr Wille- Kat made a 3D print for grip
- Monday- meeting at 315 office hours to MTS test
- Do skin and larynx testing separately
- Asian market on park street- pig skin meat cut- connect with skin marking team
- Putting BME posters on the resume- how do we do it?
  - Project experience section
  - Highlight specific skills
- Solidworks testing- working on it
- If we can't do MTS testing, just do some sort of data- like us puncturing through skin and rating it
- Take pictures of hole during testing
- Airflow- next semester
- Put thumb in top of design- may not even need a handle
- Dr Suarez thinks it would be best to work on a way to secure the device
- Send her the poster before we print it- tuesday
- Extra meeting with Dr Suarez after final posters- the following friday
- Dr Suarez doesnt think having an exact measurement/placement map won't be as useful because anatomy is so different
- Test trachea too on MTS
- Why is the cricothyroid membrane used as opposed to the regular trachea?
- Talk to WARF next semester

**Conclusions/action items:**

Following this advice, the group will move forward with testing this semester. Next semester we have a decent start on a plan of what we want to accomplish.



## Material Expenses Table

Zac Mayhew - Dec 13, 2023, 2:16 PM CST

**Title:** Material Expenses Table

**Date:** 12/12/2023

**Content by:** Whole Group

**Present:** n/a

**Goals:** The goal of this document is to outline all of the expenses from this semester.

**Content:**

Item	Description	Supplier	Part/Model #	Date	QTY	Cost Each	Total	Link
PLA Print of Design	3D printed prototype that will be utilized in initial testing.	UW-Makerspace		10/16	1	\$0.16	\$0.16	<a href="#">Link</a>
3D Print of Trachea	3D printed representation of trachea for modeling purposes.	UW-Makerspace		10/27	1	\$6.24	\$6.24	<a href="#">Link</a>
3D Print of Larynx	3D printed representation of larynx for modeling purposes.	UW-Makerspace		10/27	1	\$10.41	\$10.41	<a href="#">Link</a>
PLA Print of Prototype	3D printed re-dimensioned prototype to be used in testing.	UW-Makerspace		11/8	1	\$0.38	\$0.38	<a href="#">Link</a>
PLA Print of Prototype	3D printed re-dimensioned prototype to be used in testing.	UW-Makerspace		11/17	1	\$0.48	\$0.48	<a href="#">Link</a>
Porcine Larynx	Fresh porcine larynx used in testing on the MTS machine.	USDA Meat Plant		11/28	1	\$10	\$10	<a href="#">Link</a>
3D printed grips for the MTS machine	3D printed grips to be used in testing on the MTS machine.	UW-Makerspace		12/1	3	\$0.67	\$2	<a href="#">Link</a>
<b>TOTAL:</b>							\$29.67	





Megan Finell - Dec 13, 2023, 9:06 PM CST



[Download](#)

**IMG\_5853.HEIC (2.71 MB)**

Megan Finell - Dec 13, 2023, 9:06 PM CST



[Download](#)

**IMG\_5852.HEIC (2.63 MB)**

Megan Finell - Dec 13, 2023, 9:06 PM CST



[Download](#)

**IMG\_5851.HEIC (2.43 MB)**

Megan Finell - Dec 13, 2023, 9:06 PM CST



[Download](#)

**IMG\_5855.HEIC (2.35 MB)**



## Final Prototype Fabrication

---

**Title: Final Prototype Fabrication****Date:** 12/10/2023**Content by:** Zac, Mateo, Megan**Present:** Zac, Mateo, Megan**Goals:** The goal of this document is to outline the fabrication protocol so in the future we can follow it to make multiple devices.**Content:**

## Machining on Lathe

1. **Setting up the lathe:** Measure the diameter of the aluminum stock. Place the aluminum stock in the chuck with approximately 2 inches hanging out. Insert the cutting tool into the tool post, and set the machine into high gear. Make sure to rotate the chuck while changing gears to allow them to mesh. Pull the spindle lever upwards to start the lathe. Adjust the RPM of the machine to approximately 1000 RPM. If machining the part out of a different material, consult the RPM tool to determine the correct RPM. The chuck should be spinning counterclockwise.
2. **Zeroing the Z-axis:** Do this by moving the tip of the cutting tool towards the face of the part. Once light contact is made, use the x-axis handwheel to move the tool off the face of the part. Stop the machine and zero the z-axis on the DRO. Turn the z-axis handwheel until the DRO reads -0.015". Zero the DRO again, and face off the part. Make sure to only move the x-axis handwheel when facing off.
3. **Setting the X-axis diameter:** Move the cutting tool along the z-axis until it is along the edge of the part. Slowly turn the x-axis handwheel clockwise until light contact is made against the diameter of the part. Turn the z-axis handwheel clockwise to move off of the part. Make sure not to move the x-axis handwheel at this time. Turn the machine off, and set the x-axis measurement on the DRO to the measured diameter of the stock.
4. **Cutting the major diameter:** Set the x-axis on the DRO to the outer diameter of the part, 0.990". Moving only the z-handwheel, take the cutting tool down the length of the part, stopping about 0.2" before the spindle. Stop the spindle and measure the diameter of the part. Update the DRO diameter reading if the numbers do not match. Make a final pass to create the actual outer diameter of 0.9843". Move slowly to ensure a good surface finish.
5. **Cutting the minor diameter:** While taking 0.03" cuts, move the cutting tool to -0.7800 in the z-axis. Continue cutting until a diameter of 0.25" is reached. This should take about 26 cuts. Now do the final pass. Set the x-axis to the final part diameter, 0.2362. Move the cutting tool down the length of the part until the final length is reached, -0.7874". Slowly turn the x-handwheel counterclockwise to remove the cutting tool from the face.
6. **Spot drilling the minor diameter channel:** Remove the cutting tool from the tool post. Place the keyless chuck into the tailstock. Secure the spot drill into the chuck. Move the tailstock towards the part, lock it in place. Touch the spot drill to the face of the part and zero the digital readout. Retract the chuck away from the material and turn the spindle on at approximately 800 RPM. Spot drill until a readout of -0.04" is reached.
7. **Drilling the minor diameter channel:** Next, the 0.1572" diameter channel will be drilled out. Use a 5/32" bit, or a more accurate drill bit if available. Turn the spindle on at 1000 RPM. Peck drill until a depth of approximately 1.000". Make sure to completely remove the bit out of the hole while drilling to remove debris.
8. **Cutting off excess stock:** Using the drop saw, cut the excess stock off of the part. For aluminum, the drop saw should run at 200 RPM. Leave an extra 0.1" or so the part can be machined to it's final length. For example, the final part length is 1.6929", so make the cut at 1.8"
9. **Cutting the part to its final length:** Measure the length of the major diameter section. Place the part back in the lathe chuck, with the major diameter facing outwards. Set the cutting tool into the tool post, and face off the part. Set the z-axis DRO to the measured length. Taking 0.03" cuts, cut the length of the part down to 0.92". On the final pass, take a cut at 0.9055", moving the x-handwheel slowly to ensure a good surface finish.
10. **Spot drilling the major diameter channel:** Remove the cutting tool and place the spot drill into the keyless chuck. As before, zero the spot drill against the face of the material. At 800 RPM, spot drill until a depth of -0.04".

11. **Drilling the major diameter channel:** Finally, the 0.8661" diameter channel will be drilled. Use a 5/64" bit, or a more accurate drill bit if available. Turn the spindle on at 275 RPM. Peck drill until a depth of approximately 0.7874". Make sure to completely remove the bit out of the hole while drilling to remove debris. Next, replace the bit with a flat end mill of the same diameter. At as slow an RPM as possible (~237 RPM), drill down to the same length as before. This creates the flat bottom of the channel
12. **Part Deburring:** Move the carriage away from the chuck. Then, at 300 RPM, use a file to knock off the sharp edges. File down all sharp edges, on both sides of the part. Use swivel head deburring tools to clean up the inside of the minor diameter channel.

### Machining on Mill

6. **Setting up the Mill:** Place the piece in a 63/64" collet block to secure it. Using a 45° angle block, clamp the piece down at an angle. Place a 1/2" 2-flute aluminum endmill in the collet, and load the collet into the spindle.
7. **Zeroing the z-axis:** Align the tip of the part with the drill bit. Turn the mill on at 1000 RPM. Raise the z-axis upwards until contact is made with the part. Zero the z-axis on the DRO.
8. **Creating angled edge:** Removing ten thousandths of material in each pass (0.01"), begin taking material off the end of the tip. Make sure to use cutting oil for lubrication and cooling. One may need to move the part in the x and y axes to ensure the entire tip is machined. Move more slowly as you begin taking off more material with each pass. Stop when a z depth of -0.167" is reached.
9. **Removing the endmill:** Remove the part from the clamp and turn it over so that the longer end of the needle is facing upwards. Reclamp the piece and lower the table. Ensure that the quill is all the way up and locked, then remove the collet and endmill. Load the keyless chuck into the spindle and place the edge finder into the chuck.
10. **Zeroing the y-axis:** Maneuver the table and quill until the edge finder is along the side of the shaft. Turn the mill on at 800 RPM. Slowly move the edge finder until it makes contact with the side of the shaft closest to you. Keep going until the edge finder begins to break the other way. Raise the quill and zero the y-axis on the DRO. Compensate for the radius of the edge-finder by setting the y-readout to 0.250", then zero again. Next, use the edge finder to locate the edge of the other side of the shaft. Make sure to compensate for the radius of the edge finder. Note the diameter of the shaft you just found. Zero the y-axis again, so that it is zero at the edge of the shaft. Move the y-axis the distance of the radius of the shaft and zero it one last time.
11. **Zeroing the x-axis:** Place the edge finder near the tip of the shaft, where the y-axis DRO reads 0.0000. Gradually turn the x-handwheel until the edge finder makes contact, then breaks the other way. Zero the x-axis on the DRO. Remove the edge finder from the keyless chuck.
12. **Spot drilling the additional hole:** Place the spot drill into the keyless chuck. Move the part until the DRO reads 0 in the y-axis and -0.345 in the x-axis. Bring the quill down until it touches the part, then zero the quill readout. Turn on the spindle at a speed of 1000 RPM. Tap the spot drill until it just makes contact. Make sure not to drill too far as to make a spot drill hole which is larger than the drilled hole. Remove the spot drill from the keyless chuck.
13. **Drilling the additional hole:** To create the additional hole, which has a 0.0787" diameter, use a 5/64" bit, or a more accurate drill bit if available. Lower the quill until the bit touches the part and zero the quill readout. At 1500 RPM, drill through only one side of the shaft, approximately a depth of 0.03935".
14. **Part Deburring:** Use a file to deburr the angled edge created. Use a swivel head deburring tool to reach the inner portion of the angled edge. Finally, use a countersink deburring tool to clean up the additional hole.

### Sharpening on Bench Grinder

1. **Creating a Beveled Edge:** Using a bench grinder or other sharpening tool, grind each side of the tip of the device to a 45° angle. This creates a sharp point similar to that of a hypodermic needle.

### Conclusions/action items:

Next semester we will refer to this document when we are creating more prototypes and possibly prototypes of different sizes.



## Show and Tell Survey

---

ANNIKA ROSSEBO - Nov 16, 2023, 10:10 AM CST

**Title:** Show and Tell Survey

**Date:** 11/10

**Content by:** Kat

**Present:** All

**Goals:** The goal of this document is to display the show and tell survey that we distributed.

**Content:**

1. On a scale of 1 to 5, how approachable is this device? (1 being completely intimidated by this device, 5 being able to slip into pocket and use comfortably) \_\_\_\_\_
2. On a scale of 1 to 5, how prepared do you feel to use this device? (1 being needing extensive/higher level education training, 5 being able to use this device within a minute's notice) \_\_\_\_\_
3. On a scale of 1 to 5, how much force do you imagine you would need to apply to use this device? (1 being immense force, needing to rely on a strong, muscular user, 5 being as much force to push a fluid out of a syringe) \_\_\_\_\_
4. On a scale of 1 to 5, how confident are you that you could identify the cricothyroid membrane using the directions provided (1 being extremely unconfident, 5 being extremely confident) \_\_\_\_\_
5. Using the directions provided, how long do you think it would take you to identify the cricothyroid membrane (please provide in minutes) \_\_\_\_\_

**Conclusions/action items:**

Please see separate LabArchives entries for the data and results of this survey.



# Preliminary Force Testing Protocol

---

**Title: Preliminary Force Testing Protocol****Date:** 11/15/23**Content by:** Annika**Present:** Annika**Goals:** The goal of this document is to state the protocol and setup used for preliminary force testing.**Content:****Materials**

- Dr. Meter ES-PS01 Force Gauge
- 3 clamps
- Plastic skin mimetic
- Cricothyroidotomy device(s)
- Embroidery floss

**Protocol**

1. Clamp skin mimetic between 2 tables using clamps, pull taught
2. Clamp force gauge onto the table
3. Create a loop of embroidery floss, double knotted
4. Connect the cricothyroidotomy device and the hook on the force gauge using the embroidery floss loop
5. Place the tip of the cricothyroidotomy device onto the surface of the skin memetic and pull taught
6. Zero force gauge
7. Cricothyroidotomy device pushed fully through the skin memetic, simultaneously record the max force needed to push the device through
8. Reset the cricothyroidotomy device at a different part of the skin mimetic for a new piercing
9. Repeat steps 5-8 for all trials
10. Convert lbs of force from force gauge to newtons

**Setup**





- Source of error: device error (5-10grams), also measured pulling force not pushing force

#### Sources of error

There are two main limitations of this testing. The first important limitation is that the Dr. Meter ES-PS01 force gauge can only measure pulling force, not pushing force. Ideally, the pushing force would be measured for this device. The current testing setup was designed to measure the force as accurately as possible without having a device that can measure pushing force. The second important limitation of this test is that the device is accurate to 5-10 grams which may introduce minor sources of error into the data.

#### Conclusions/action items:

Please note the important sources of error for this testing above. This force testing will be completed for the second cricothyroidotomy device, the client's prototype, and possibly future prototypes. This protocol and the corresponding data will be reported to the design team and the advisor.



## Solidworks Strength Simulation Protocol

---

Zac Mayhew - Dec 13, 2023, 1:51 PM CST

**Title:** Solidworks Strength Simulation Protocol

**Date:** 12/2/2023

**Content by:** Zac

**Present:** n/a

**Goals:** The goal of this document is to outline what was done to test the design in solidworks.

**Content:**

1. Apply a force to the tip of the piece equivalent to 2.5 N (force needed to penetrate skin).
2. Run the simulation in solidworks.
3. Get values for the max stress, strain and factor of safety.
4. Compare the results of the test for aluminum and plastic that is similar to PLA.
5. You have to create the PLA using a custom material and material properties from the internet.

**Conclusions/action items:**

Now the results of the two simulations need to be compared.



## Show and Tell Survey Data

---

**Title: Show and Tell Survey Data****Date:** 11/10/23**Content by:** Annika**Present:** Annika, Zac, Megan, Mateo, Kat**Goals:** The goal of this document is to display our data from the show and tell survey.**Content:**

<b>Student</b>	<b>Q1: How approachable is this device?</b>	<b>Q2: How prepared do you feel to use this device?</b>	<b>Q3: How much force do you imagine you would need to use the device?</b>	<b>Q4: How confident are you that you could identify the cricothyroid membrane?</b>	<b>Q5: How long do you think it would take you to identify the cricothyroid membrane? (minutes)</b>
1	3	3	2	3	2
2	4	3	3	2	1.5
3	5	3	2	2	1
4	5	3	3	4	1.5
5	4	3	4	5	1
6	3	3	4	4	0.5
7	5	2	2	3	1
8	2	2	3	2	0.5
9	2	3	3	3	1.5
10	2	4	4	2	0.5
11	3	2	2	3	1
12	3	4	4	3	1.5
13	3	2	3	3	1
14	4	2	3	5	1
15	3	3	2	4	1
16	3	2	3	4	2
17	2	2	2	3	1
18	1	4	2.5	5	1
19	1	2	4	2	2
20	2	2	4	2	2
21	4	3	5	3	3
22	2	3	2.5	2	2.5
23	2	3	4	2	4
24	2	3	1	2.5	1.5

**Conclusions/action items:**

The purpose of this survey was to gain honest feedback from our peers on how they felt about the possible use of this device. Please see a separate LabArchives entry for the results from this study.



# Show and Tell Survey Results

---

**Title: Show and Tell Survey Results****Date:** 11/16/23**Content by:** Annika**Present:** Annika**Goals:** The goal of this document is to display the results from the show and tell survey.**Content:**

Team members would give a ~1 minute elevator pitch for the product, including a brief explanation and demonstration of how to locate the cricothyroid membrane. Following the elevator pitch, the following survey results were collected.

**Total survey responses:** 24**Total questions:** 5

1. On a scale of 1 to 5, how approachable is this device? (1 being completely intimidated by this device, 5 being able to slip into pocket and use comfortably)

**Mean:** 2.92**Median:** 3**Range:** 1-5

2. On a scale of 1 to 5, how prepared do you feel to use this device? (1 being needing extensive/higher level education training, 5 being able to use this device within a minute's notice)

**Mean:** 2.75**Median:** 3**Range:** 2-4

3. On a scale of 1 to 5, how much force do you imagine you would need to apply to use this device? (1 being immense force, needing to rely on a strong, muscular user, 5 being as much force to push a fluid out of a syringe)

**Mean:** 3**Median:** 3**Range:** 1-5

4. On a scale of 1 to 5, how confident are you that you could identify the cricothyroid membrane using the directions provided (1 being extremely unconfident, 5 being extremely confident)

**Mean:** 3.06**Median:** 3**Range:** 2-5

5. Using the directions provided, how long do you think it would take you to identify the cricothyroid membrane (please provide in minutes)

**Mean:** 1.48

**Median:** 1.25

**Range:** 0.5-4

**Conclusions/action items:**

It is important to note that these results would likely be different if the survey was given to the general public. These survey responses were collected from seniors in Biomedical Engineering who have more knowledge of anatomy than the general public, which may introduce sources of error in this data. While these data show results in the middle, it is still conclusive.





## Preliminary Force Testing Data- Second Prototype

---

ANNIKA ROSSEBO - Nov 16, 2023, 10:41 AM CST

**Title:** Preliminary Force Testing Data- Second Prototype

**Date:** 11/15/23

**Content by:** Annika

**Present:** Annika

**Goals:** The goal of this document is to report the testing data for the second prototype.

**Content:**

### 2nd cricothyroidotomy device data (measured in lbs force)

Trial 1: 2.02

Trial 2: 1.99

Trial 3: 1.84

Trial 4: 2.80

Trial 5: 2.22

### Conclusions/action items:

Please note the important sources of error for this testing in the protocol document This force testing will also be completed for the client's prototype, and possibly future prototypes. This data will be reported to the design team and the advisor.



## **Solidworks Strength Simulation results**

---

### Title: Solidworks Strength Simulation Results

Date: 12/3/2023

Content by: Zac

Present: n/a

Goals: The goal of this is to document the results from the solidworks simulations done on the final prototype using PLA and aluminum.

Content:

Aluminum:

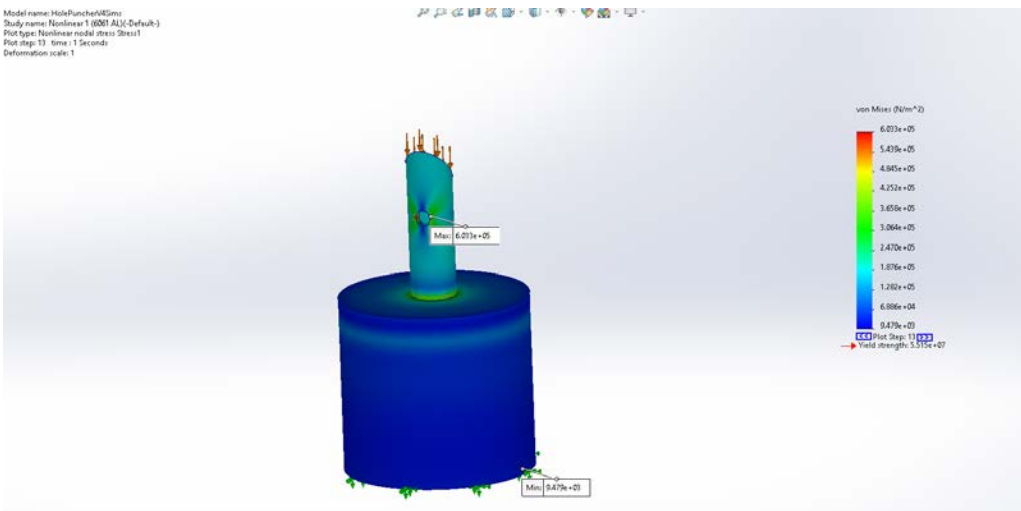

Stress:

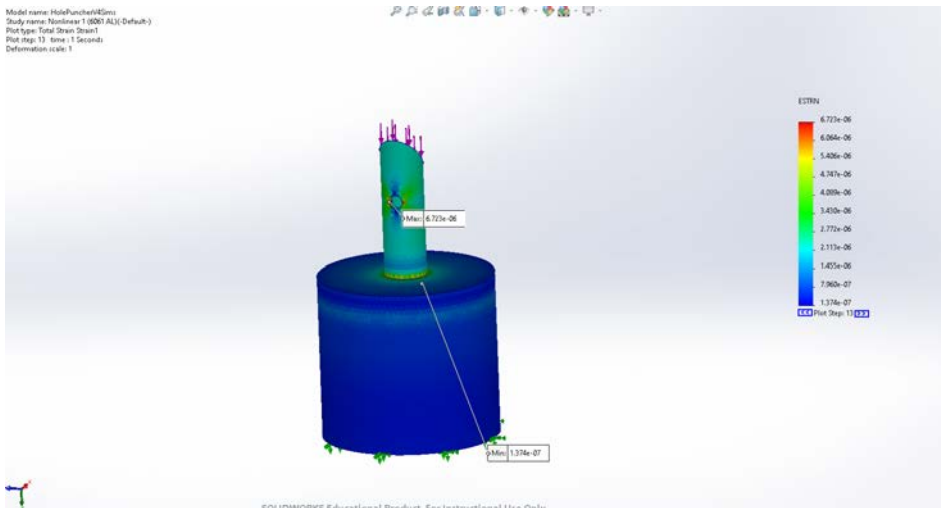

Strain:

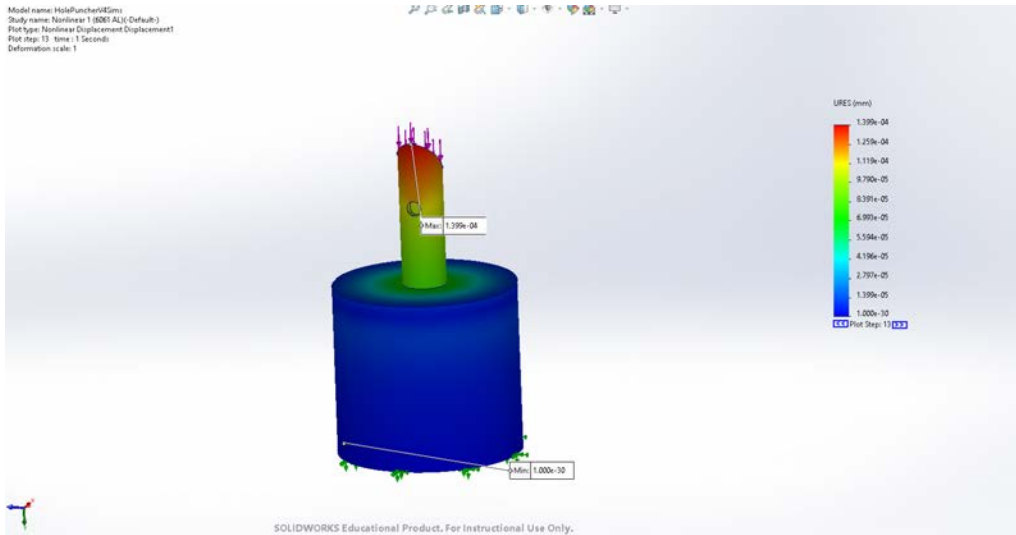

Displacement:

PLA:

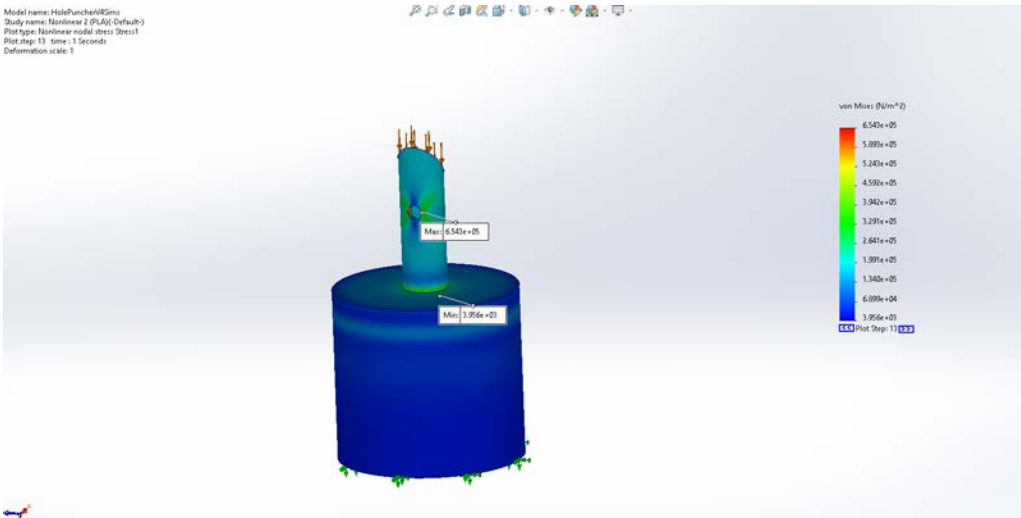

Stress:

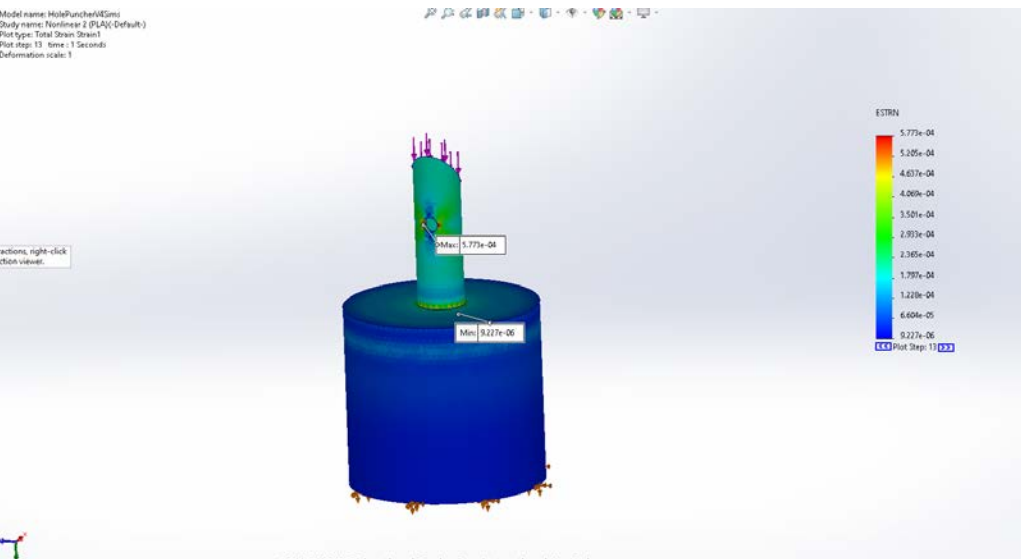

Strain:

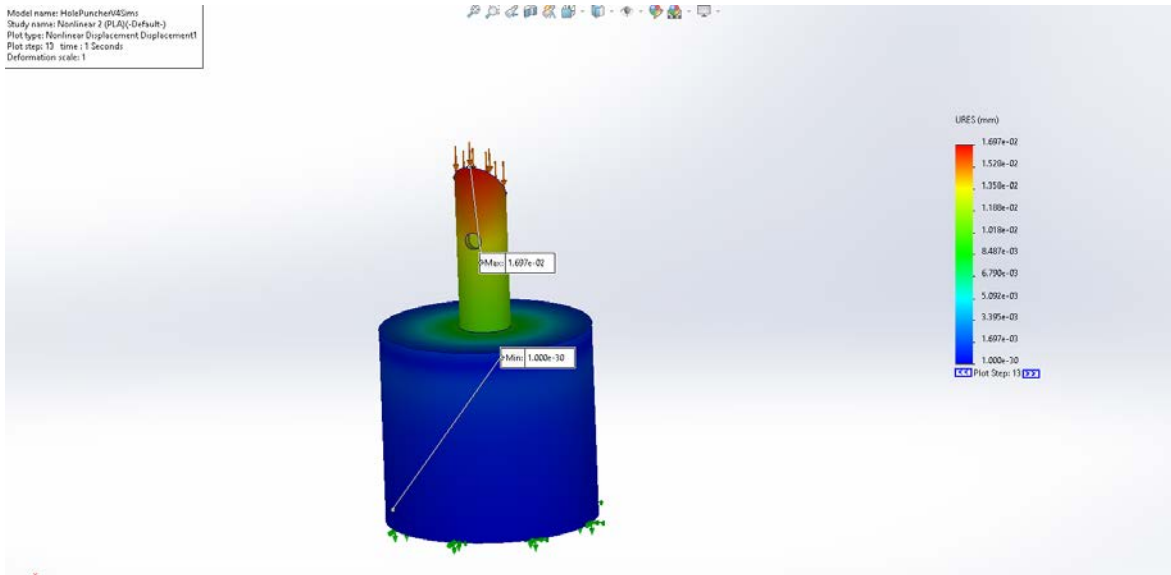

Displacement:

Results: Based on the simulation, the PLA is slightly weaker than the aluminum. This is what we expected to be the case but now we have data supporting our hypothesis.

### Conclusions/action items:

The results from the simulation will be brought to the client and allow us to move forward with aluminum confidently.



## MTS Testing Protocol

ANNIKA ROSSEBO - Dec 13, 2023, 8:25 PM CST

**Title:** MTS testing protocol

**Date:** 12/13

**Content by:** All

**Present:** Kat, Annika, Megan

**Goals:** The goal of this document is to record the testing protocol for the MTS machine.

**Content:**

**Porcine Tissue Prepping protocol:**

1. Acquire porcine larynx tissue, with external adipose tissue
2. Remove excess tissue from larynx with a scalpel
  1. Ensure that the cricothyroid membrane is intact and undamaged
3. Trim the trachea to 4 inches
4. Place larynx in a bag and soak tissue in 0.9% saline solution
5. Freeze sample at  $-80^{\circ}\text{C}$
6. Thaw sample in heat bath, heated to  $23^{\circ}\text{C}$  1 hour before MTS testing
7. Remove sample from bag and pat dry to remove excess solution
8. Trim sample to fit in a petri dish with the cricothyroid membrane in the middle
9. Adhere with Loctite 401 glue
10. Hydrate the larynx every 5 minutes with 0.9% saline spray

**MTS test protocol for use with the MTS Inspiron machine:**

1. Attach the 50 N load cell
2. Attach the custom 3D printed grip to the metal prototype and the MTS grips
3. Place the porcine tissue on a petri dish
4. Set up the petri dish under the load cell with the cricothyroid membrane directly beneath the prototype
5. Open the compression test file on TW Elite
6. Set the test rate to 3.00 mm/s, strain end point to 6.000 mm/mm, and the data acquisition rate to 10.0 Hz
7. Lower the prototype and load cell to just touch the porcine larynx
8. Zero the system
9. Click play on the TW Elite software
10. Watch for a spike of force on the graph or for a puncture in the larynx

**Conclusions/action items:**

The results of this testing were discussed with the team. Overall, the strain rate was too slow to mimic the actual puncture needed for the cricothyroid membrane.



## 2023/9/8 - Team Meeting 1

---

**Title:** First Meeting!!

**Date:** 9/8/2023

**Content by:** Katerina

**Present:** Megan, Matteo, Annika, Zac

**Goals:** Understand the project and get set up

**Content:**

- 1) Swap Enrollment--Everyone was successful except for Mateo and Zac, so they need to email Dr. P
- 2) Team Roles--Zac is team leader, Kat is communicator, Annika is BSAC, Megan is BPAG, Matteo is BWIG
- 3) Created google drive, group chat and lab archives
- 4) Emailed Dr. Suarez

Next steps: research and meeting with client

Kat has already set an email to the client and the advisor, hopefully everyone will respond soon.

Questions to ask the client:

1. Do we have to worry about local anesthesia to apply for the device?
2. Who will use the device? The general joe? Or someone who is trained?
3. Size of the device? Is this going to be stored in a first aid kit?
4. How far should the device puncture?
5. What materials and supplies does our client have for testing purposes?
6. What is our budget?
7. Is this going to be designed particularly for kids?
8. What is our client's role at the hospital?
9. Should this device be single use?
10. How does this compare to current devices on the market? Where is the novelty?
11. Why does the market need this type of device?
12. Is this only used in emergency situations?
13. Will this be used in the hospital or in the field?
14. Do you only have 'one shot' to use this device?
- 15.

**Conclusions/action items:**

We will establish a weekly meeting time with Dr. Suarez, a weekly team meeting time, and a first meeting time with our client. We will individually complete preliminary research on anatomy and current market devices, as well as come up with questions to ask our client.





## 2023/9/22 - Team Meeting 2

---

ANNIKA ROSSEBO - Sep 22, 2023, 3:47 PM CDT

**Title:** Team meeting 2

**Date:** 9/22/23

**Content by:** Annika

**Present:** Mateo, Zac, Katerina, Annika, Megan

**Goals:** Our goal is to define goals for the weekend

**Content:**

- Our client said over email that he wants the device to be 3.25 inches long
  - We should try to find this study
  - It was from a military study
- He also wants this device to be able to used for a tension pneumothorax

**Conclusions/action items:**

Action items:

- Each create a design idea
- PDS edits
  - Need a weight
  - Need size of device
  - Need to revise puncture/incision size
  - Submit PDS
- Clarify/solidify budget with client
- Keep individual design notebooks updated for individual presentation next week
- Research sharp plastic devices as ideas for our design
- Complete design matrix

Team meeting: Wednesday 9/27 at 7:00pm at the Business School



## 2023/10/13 - Team Meeting 3

---

Mateo Silver - Oct 13, 2023, 12:30 PM CDT

**Title:** Team Meeting 3

**Date:** 10/13/23

**Content by:** Mateo

**Present:** Mateo, Zac, Kat, Annika, Megan

**Goals:** Begin talking about fabrication.

**Content:**

- 3D printing is easy for fast prototyping
- Can change materials easily
- Try out PLA for first prints, maybe move onto resin if we need a more refined prototype
- Add additional hole into CAD model before printing
- Action items:
  - Update the CAD model, Zac
  - Find a day to print the model, Monday?
  - Kat talking to PI about testing on porcine larynges

**Conclusions/action items:**

**Begin fabrication next week.**



## 2023/10/27 - Team Meeting 4

---

ANNIKA ROSSEBO - Oct 27, 2023, 12:34 PM CDT

**Title:** Team meeting 4

**Date:** 10/27/2023

**Content by:** Annika

**Present:** Kat, Megan, Mateo, Zac, Annika

**Goals:** Our goal is to document team notes and action items for the next week or so.

**Content:**

- Items completed since last week
  - Zac edited the 3D printed prototype to be able to interface with a BVM and have the extra hole and researched how to palpate a cricothyroid membrane
  - Mateo created fabrication protocol
  - Kat worked on testing protocol
  - Annika researched skin mimetics
  - Megan did materials research for testing and prototype materials
- Action items for next week
  - 10/31 12:30 team lab consultation- talk to the team lab about which materials we should fabricate from
  - Fabricate prototype
  - Show and tell- focus on if people think they could actually use this
  - Get skin mimetic from BME closet
  - Megan will make instruction manual for usage of the device
  - Megan will also contact people about pig larynges
  - Zac will write instruction manual and send it to Megan
  - Kat will make the survey for show and tell and contact people about pig larynges
  - Annika will start testing with the skin mimic and work on a survey for first responders/nurses
  - Mateo will reach out to his outreach contact for the high school robotics team
- Received from Dr Suarez: pediatric trach tube, pediatric trach tube holder

**Conclusions/action items:**

Our individual and team action items are outlined above. We are looking forward to show and tell!



## 2023/10/31- TEAM lab consultation

---

Title: TEAM lab consultation 10/31

Date: 10/31

Content: Annika

Present: Annika, Megan, Mateo, Kat

Objective: The objective of this document is to note key points from our meeting with the TEAM lab.

Notes:

- TEAM lab brought up the fact that our current design may need a way to dislodge any stuck tissue after insertion
- They suggested that we purchase a thin diameter piece of stainless steel to make the main cannula, instead of the piece of aluminum we had
- They suggested we look into it stainless steel will set off metal detectors at airports
- They discussed how we could fabricate our new design using a melting technique which involves heating the outer/top diameter part that interfaces with the BVM, inserting the smaller diameter cannula, and then cooling the device to shrink the top part onto the cannula
- They said that our design can be made with mostly laithing, and some milling
- They suggested 2 methods for sharpening the bevel: using a small diameter cannula, and sharpening either end of the bevel to create more of a point
- Our team showed the TEAM lab members Mateo's fabrication plan, and they approved of it. They only suggested starting with the larger end and keeping it long for ease of fabrication
- The TEAM lab also suggested considering a sliding ball mechanism for future iterations if we were to use a

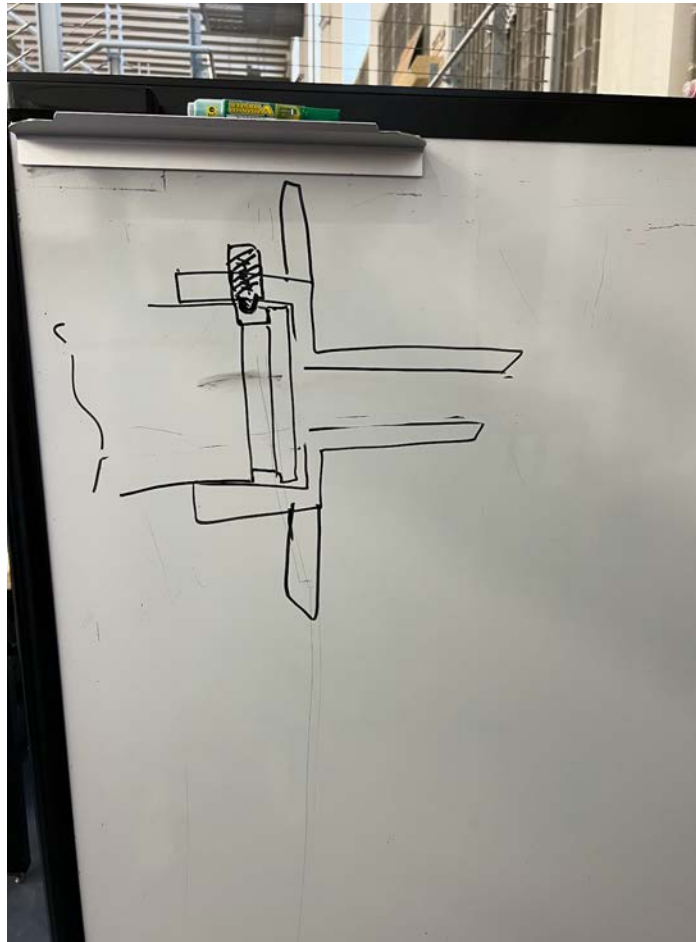

cannula/trochar design:

- They also made the following suggestion over email after our meeting: Another option for your tool: buy and shape the stainless tubing and design a plastic base for it. You could undersize the hole slightly and drill or ream it and potentially glue the metal tube in. That way you could easily experiment with sizes and shapes of bases to make it easy to use. Creating an extension would be more straightforward too.

**Conclusions/actions:**

Our team needs to decide if we will fabricate a prototype using the piece of aluminum for show and tell on Friday or postpone metal fabrication until we can order pieces from McMaster-Carr. We do have a plastic prototype and a 3D printed model of the trachea and larynx that we will use to demonstrate our device during show and tell on Friday.



## 2023/11/10 - Team Meeting 5

---

**Title:** Team Meeting 11/10

**Date:** 11/10/23

**Content by:** Megan

**Present:** Annika, Megan, Kat, Zac, Mateo

**Goals:** Discuss what we're doing in the next week as a team and our client meeting on Sunday.

**Content:**

- Meeting with client
  - 4pm on Sunday
  - Ask what he thinks of the prototype
  - Ask about the hole on the bevel side of prototype
  - Ask about the map thing on patient for anatomical landmarks (that Mateo just made)
  - Ask client about using aluminum for device
  - Ask/tell about the results to our survey at Show and Tell
- Prototype talk
  - Hole is not yet in the trachea
  - Should try to make out of the aluminum rod
    - Need CAD drawings in imperial units (in)
- Testing
  - Start testing next week on skin
  - Use force meter to see how much force it takes to push through skin
    - By the end of the day on Tuesday
  - Try to do testing the week we come back from Thanksgiving
- Larynx prices
  - Can usually get on larynx for \$15
  - Megan will email Dillon (from Meat Processing and Packaging Center on campus)
- BVM matching
  - Zac will bring prototype to EMT class and see if BVM clashes with dimensions (on Tuesday)

**Conclusion/Action Items:**

Plan for next week/this weekend:

- Annika doing force testing next week
- Megan will reach out to Dillon (want to have it soon if possible)
- Zac will bring prototype to EMT class
- Zac will complete Solidworks testing on prototype
- Mateo, Megan, and Zac will make metal prototype before Thanksgiving



- Kat will talk to Dr. Suarez about flow testing

Before Thanksgiving:

- Finalize drawing in Solidworks
- 3D print another prototype (of final drawing)
- Test in Solidworks
- Fabricate out of metal in TEAM Lab



## 10/27/23 Skin Mimetics for Testing

---

**Title:** 10/27/23 Skin Mimetics for Testing

**Date:** 10/27/23

**Content by:** Annika

**Present:** Annika

**Goals:** My goal is to document my research on skin mimetics that we can use for testing our device.

**Content:**

- Amazon artificial skin for practicing tattoos:
  - <https://www.amazon.com/PIXESTT-Supplies-Beginners-Experienced-Artists/dp/B089B2DXVT>
  - \$12

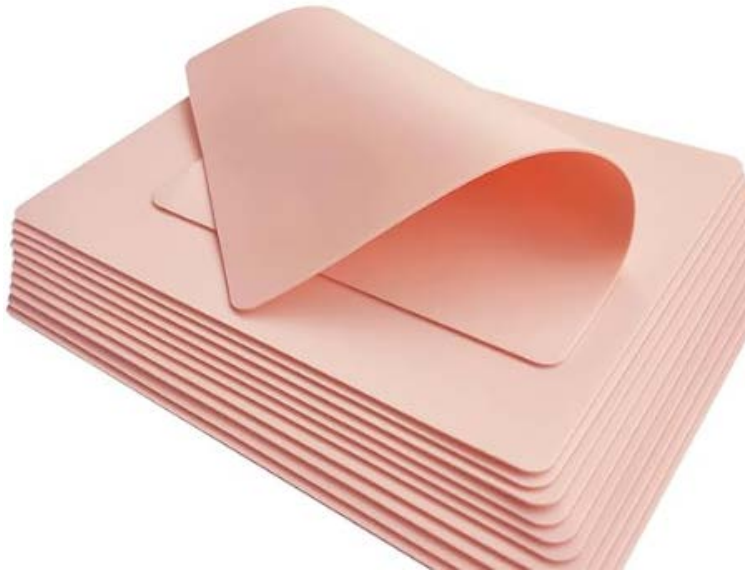

- 
- Vitro-Skin for product development
  - <https://ims-usa.com/vitro-skin-substrates/vitro-skin/>
  - \$200 starter kit
- Suture practice pad
  - [https://www.amazon.com/Suture-Practice-Pad-Medical-Students/dp/B0CC3W4GPY/ref=sr\\_1\\_1?crid=I54OSLGXSTBH&keywords=simic+plastic&qid=1698424040&srefix=simic+plastic%2Caps%2C92&sr=8-1](https://www.amazon.com/Suture-Practice-Pad-Medical-Students/dp/B0CC3W4GPY/ref=sr_1_1?crid=I54OSLGXSTBH&keywords=simic+plastic&qid=1698424040&srefix=simic+plastic%2Caps%2C92&sr=8-1)
  - \$10

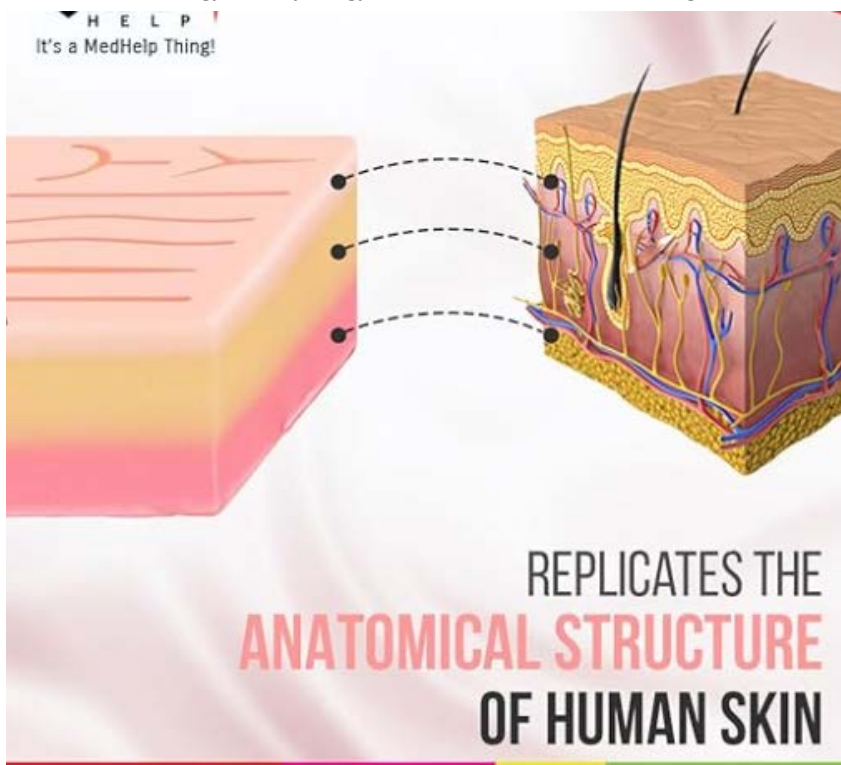

Conclusions/action items:

I will share these ideas with my team. Someone also mentioned that there may be a material we can use for testing in the BME lab closet.



# Rusch QuickTrach Cricothyroidotomy Kit

ANNIKA ROSSEBO - Sep 20, 2023, 10:33 AM CDT

**Title:** Rusch QuickTrach Cricothyroidotomy Kit

**Date:** 9/20/23

**Content by:** Annika

**Present:** Annika

**Goals:** My goal is to research devices currently on the market for emergency cricothyroidotomy.

**Content:**

This product is a pre-assembled emergency cricothyroidotomy device that features a 10 mm syringe with a stainless steel needle attached to a flexible tube and tube holder [1]. Notably, this product features a ‘safety stop’ feature on the tube holder that aims at preventing puncture of the back of the trachea. It retails for \$212.95.

“Rusch QuickTrach Cricothyrotomy Kit,” *QuadMed, Inc.* <https://quadmed.com/rusch-quicktrach-cricothyrotomy-kit/> (accessed Sep. 19, 2023).



**Conclusions/action items:**

I will research other items. This was the most expensive emergency cric kit that I was able to find for field use. This information was included in the team PDS.



## STATForce Adult Deluxe and Pediatric Field Cric Kit

ANNIKA ROSSEBO - Sep 20, 2023, 10:32 AM CDT

**Title:** STATForce Adult Deluxe and Pediatric Field Cric Kit

**Date:** 9/20/23

**Content by:** Annika

**Present:** Annika

**Goals:** My goal is to research devices currently on the market for emergency cricothyroidotomy.

**Content:**

This commercially available kit features a #10 sterile scalpel, as opposed to a needle, and a trach tube holder [1]. It also contains a 6.0 cuffed endotracheal tube and syringe to inflate the endotracheal tube balloon. Notably, this kit includes an iodine prep pad, face shield for the provider performing the procedure, and a trach hook. It is sold for \$29.95. A pediatric version of this kit is available with a 2.5 cuffed endotracheal tube and retails for the same price of \$29.95 [2].

[1] "STATForce Adult Deluxe Field Cric Kit," *QuadMed, Inc.* <https://quadmed.com/statforce-adult-deluxe-field-cric-kit/> (accessed Sep. 19, 2023).

[2] "STATForce Pediatric Field Cric Kit," *QuadMed, Inc.* <https://quadmed.com/statforce-pediatric-field-cric-kit/> (accessed Sep. 19, 2023).



**Conclusions/action items:**

I will research other items. This was the most expensive emergency cric kit that I was able to find for field use. This information was included in the team PDS.



## The Quick Fix Adult Cric Kit and The Quick Fix Jr.

ANNIKA ROSSEBO - Sep 20, 2023, 10:38 AM CDT

**Title:** The Quick Fix Adult Cric Kit and The Quick Fix Jr.

**Date:** 9/20/23

**Content by:** Annika

**Present:** Annika

**Goals:** My goal is to research devices currently on the market for emergency cricothyroidotomy.

**Content:**

This kit includes a scalpel, cuffed tube, syringe, forceps, and tape [1]. Notably, the kit contains photo directions for easy review and states the kit comes in a sterile package that takes up “very little space” (5”x8”). It retails for \$60.95. A pediatric version of this kit includes only a 1.25” large bore IV catheter, syringe, and 15mm endotracheal tube adapter. The pediatric Quick Fix Jr. is sold for \$23.95 [2].

[1] “The Quick Fix Adult Cric Kit,” *QuadMed, Inc.* <https://quadmed.com/the-quick-fix-adult-cric-kit/> (accessed Sep. 19, 2023).

[2] “The Quick Fix Jr.,” *QuadMed, Inc.* <https://quadmed.com/the-quick-fix-jr/> (accessed Sep. 19, 2023).

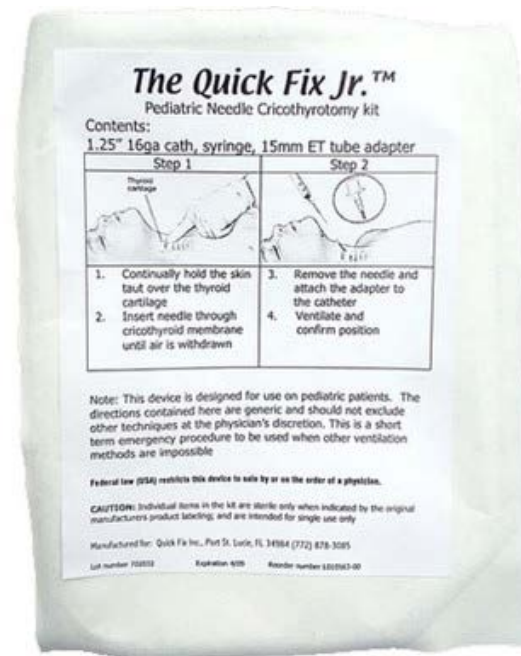

**Conclusions/action items:**

I will research other items. This was the most expensive emergency cric kit that I was able to find for field use. This information was included in the team PDS.



# **US Patent US4677978A- Emergency Cricothyrotomy System and Cricothyrotomy Kit**

---



**Title: US Patent US4677978A- Emergency Cricothyrotomy System and Cricothyrotomy Kit****Date:** 9/20/23**Content by:** Annika**Present:** Annika**Goals:** My goal is to research devices currently on the market for emergency cricothyroidotomy.**Content:**

This patent describes a device that can be inserted into the trachea through an incision. It does not include a method by which to create an incision. This patent features an over-the-needle catheter that is removed after insertion of a guide-wire [1]. From there, the cricothyroid membrane is dilated and an air passage catheter is inserted along the guide-wire. The guide-wire is then removed and the air passage catheter is secured.

[1] R. J. Melker, "SYSTEMAND CRICOTHYROTOMY KIT"

**U.S. Patent** Jul 7, 1987 **Sheet 1 of 2** **4,677,978**  
*FIG. 1.*

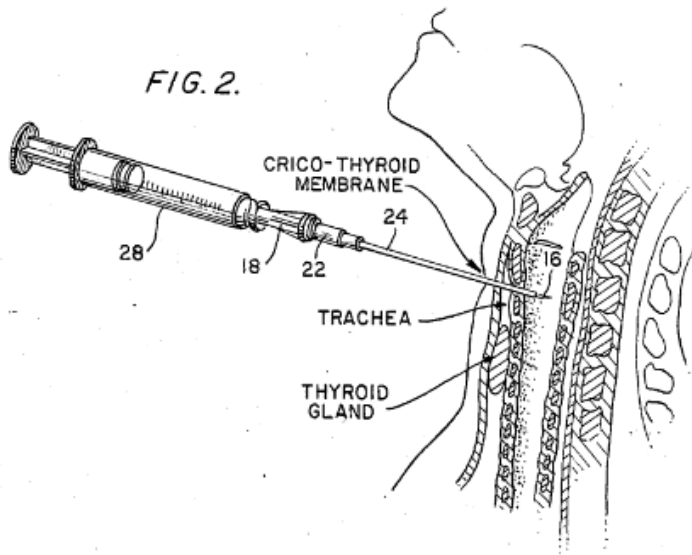
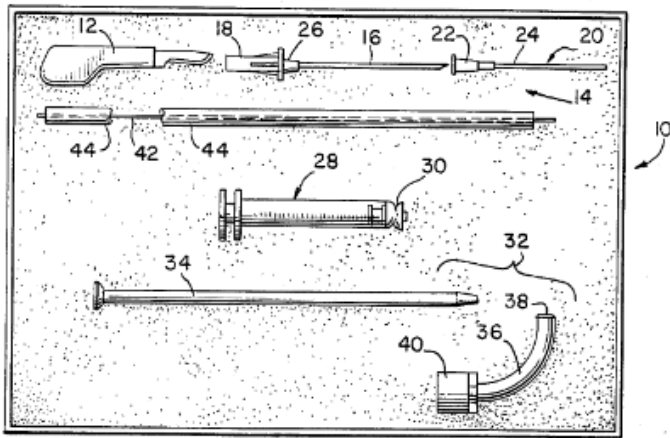

**U.S. Patent** Jul. 7, 1987 **Sheet 2 of 2** **4,677,978**

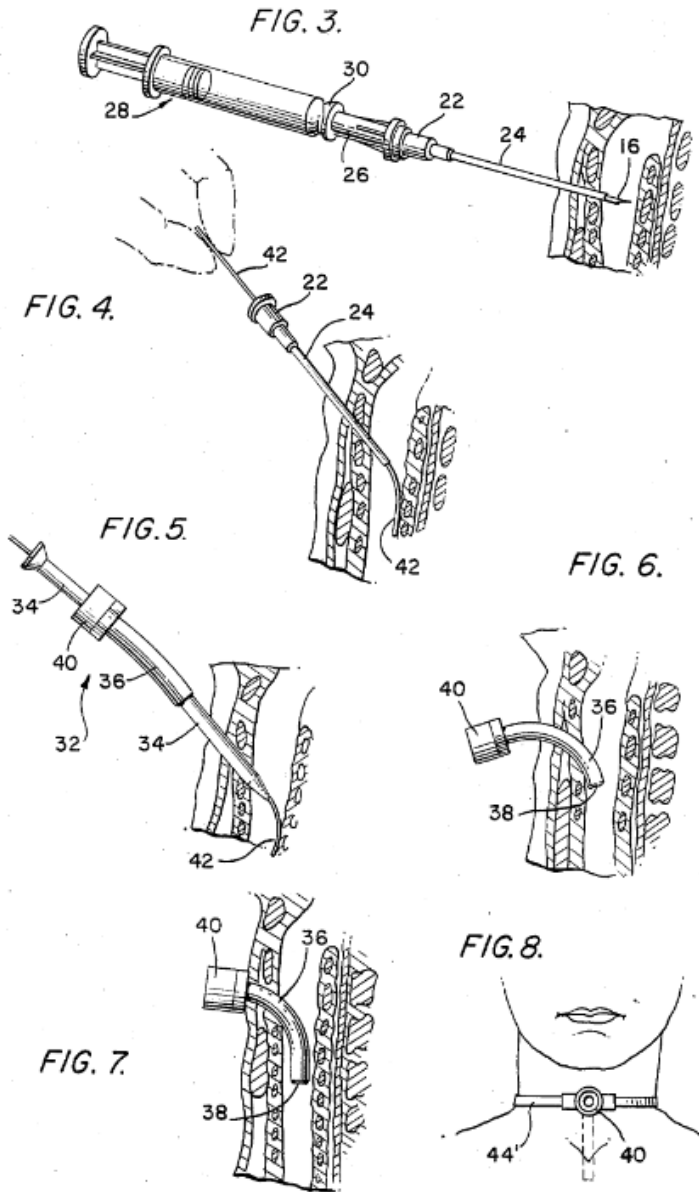

**Conclusions/action items:**

I will research other items. This was the most expensive emergency cric kit that I was able to find for field use. This information was included in the team PDS.

# US Patent US4438768A- Emergency Cricothyroidotomy Instrument

ANNIKA ROSSEBO - Sep 20, 2023, 10:46 AM CDT

## Title: US Patent US4438768A- Emergency Cricothyroidotomy Instrument

Date: 9/20/23

Content by: Annika

Present: Annika

Goals: My goal is to research devices currently on the market for emergency cricothyroidotomy.

### Content:

This patent is a single elongated needle with a sharp point and an accompanying needle holder [1]. The needle features an adapted outer shaft designed to abut the needle holder. The needle holder features ridges designed to hold the device in place. The needle and needle holder are connected by a hinge that allows for pivotal movement of each section to open and close the needle holder.

[1] R. W. Barrickman, "Emergency cricothyroidotomy instrument," US4438768A, Mar. 27, 1984 Accessed: Sep. 19, 2023. [Online]. Available: <https://patents.google.com/patent/US4438768/en>

U.S. Patent Mar. 27, 1984 4,438,768

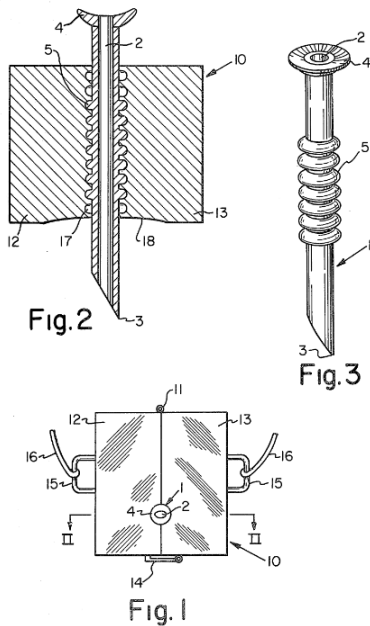

### Conclusions/action items:

I will research other items. This was the most expensive emergency cric kit that I was able to find for field use. This information was included in the team PDS.



# **US Patent US4291690A- Means for Performing an Emergency Cricothyrotomy**

---

**Title: US Patent US4291690A- Means for Performing an Emergency Cricothyrotomy****Date:** 9/20/23**Content by:** Annika**Present:** Annika**Goals:** My goal is to research devices currently on the market for emergency cricothyroidotomy.**Content:**

This device is a trocar assembly featuring an outer cannula and cutting stylet [1]. Once inserted, it is designed to be inserted two-thirds of the length of the cannula. The device maintains its position in the neck by the flaring distal end of the device.

[1] J. W. Jessen, "Means for performing an emergency cricothyrotomy," US4291690A, Sep. 29, 1981 Accessed: Sep. 19, 2023. [Online]. Available: <https://patents.google.com/patent/US4291690/en>

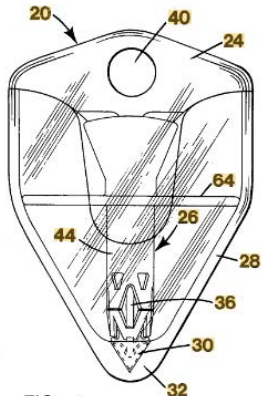

FIG. 1

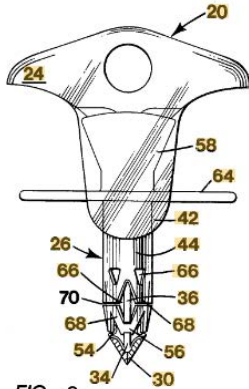

FIG. 2

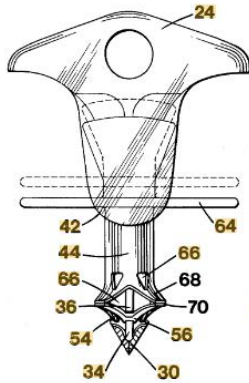

FIG. 3

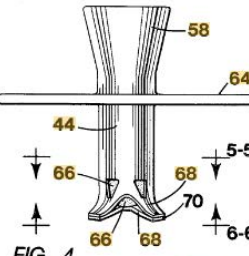

FIG. 4

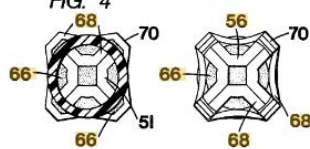

FIG. 5

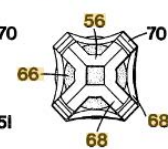

FIG. 6

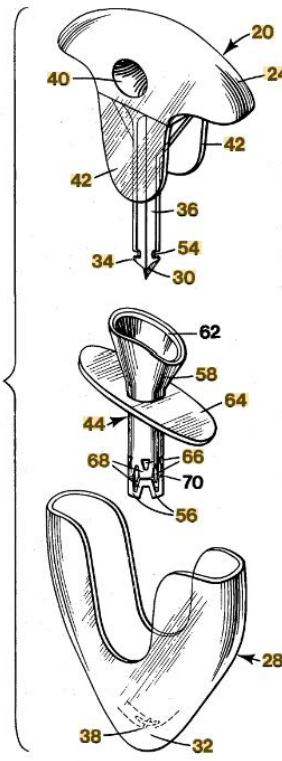

FIG. 7

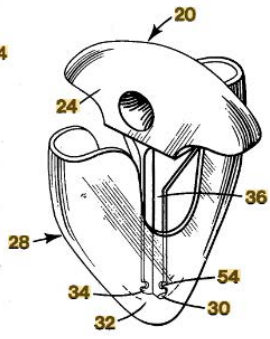

FIG. 8

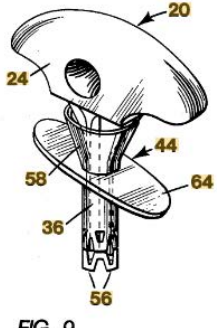

FIG. 9

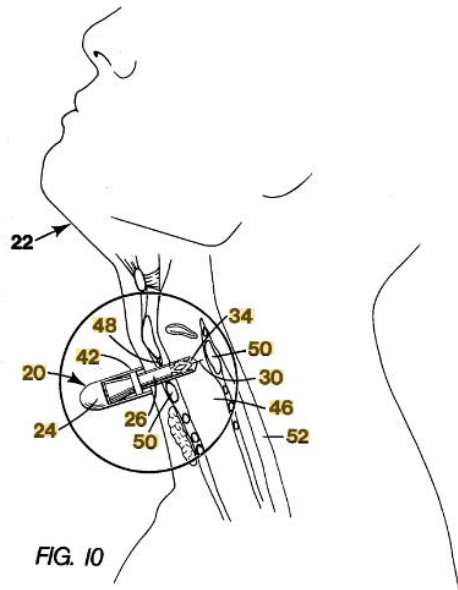

FIG. 10

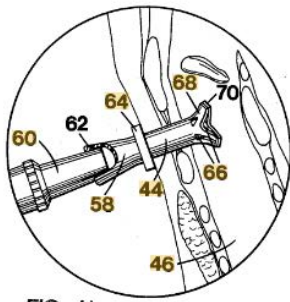

FIG. 11

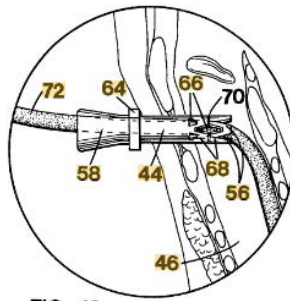

FIG. 12

**Conclusions/action items:**

I will research other items. This was the most expensive emergency cric kit that I was able to find for field use. This information was included in the team PDS.





## 10/12/23 Good Samaritan Law

---

ANNIKA ROSSEBO - Oct 13, 2023, 9:40 AM CDT

**Title:** 10/12/23 Good Samaritan Law

**Date:** 10/12/23

**Content by:** Annika Rossebo

**Present:** Annika Rossebo

**Goals:** My goal is to document my research on the Wisconsin Good Samaritan Law and how it impacts the usage of our device.

**Content:**

The client envisions any lay-person being able to use this device in the case that the Heimlich maneuver is unsuccessful at dislodging the foreign body, or in the case of other tracheal trauma. In Wisconsin, if the device were used by a lay-person and the lay-person causes undue injury to the choking victim, the lay-person could not legally be charged with injuring the victim. Wisconsin Law 895.48(1) states that any person who in good faith renders emergency care to another individual cannot be held civilly liable for any actions or omissions while rendering that care.

**Source:** "Wisconsin Legislature: 895.48(1)." Accessed: Oct. 12, 2023. [Online]. Available: <https://docs.legis.wisconsin.gov/statutes/statutes/895/ii/48/1>

**Conclusions/action items:**

I will include this image in the preliminary report and will work on my other parts of the preliminary report. I will also fill out feedback fruits.



**9/27/23 Idea 1**

---

**Title: 9/27/23 Idea 1****Date:** 9/27/23**Content by:** Annika Rossebo**Present:** Annika Rossebo**Goals:** My goal is to document one of my 3 initial designs.**Content:**Design components for all 3 of my designs:

- Made completely from plastic
- Sharp, beveled tip to piece skin and trachea
- Some sort of marking or plastic piece to stop the user from inserting the device too far and risking puncturing the esophagus
- 0.25mm diameter
- 5cm device length
- This design is based on the size of the "3/10 mL U100 insulin single use only syringe" that the client uses as a prototype for the device. It is a 31 gauge needle with a 0.25mm diameter.

Unique to this design:

- This design features a mouthpiece that could be used if the bystander needs to breathe for the choking person. This mouthpiece is inspired by the mouthpiece of a trumpet.
- This device has a slanted marking that shows the user where to insert the device until on the skin. It is slanted because the device will be inserted similarly to an IV where the bevel faces up and the cutting edge is roughly parallel with the skin
- This device features a decal that says "Call 911"

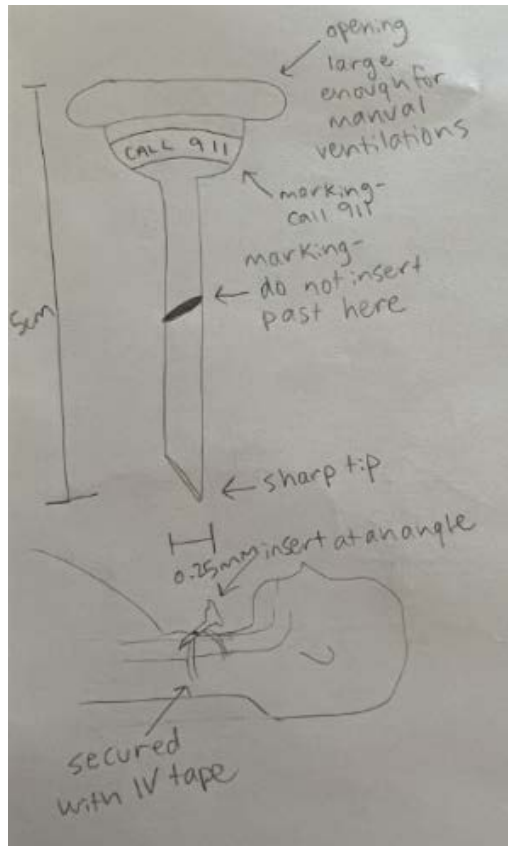
**Conclusions/action items:**

Tonight I will be meeting with my team. We will each bring 2-3 initial design ideas to the meeting and from there we will narrow the designs down to our top 3 or 4 designs. These designs will then be included in the design matrix which will be used to determine the initial prototype design. I also need to research the anatomy of the trachea.



**9/27/23 Idea 2**

---

**Title:** 9/27/23 Idea 2

**Date:** 9/27/23

**Content by:** Annika Rossebo

**Present:** Annika Rossebo

**Goals:** My goal is to document one of my 3 initial designs.

**Content:**

Design components for all 3 of my designs:

- Made completely from plastic
- Sharp, beveled tip to pierce skin and trachea
- Some sort of marking or plastic piece to stop the user from inserting the device too far and risking puncturing the esophagus
- 0.25mm diameter
- 5cm device length
- This design is based on the size of the "3/10 mL U100 insulin single use only syringe" that the client uses as a prototype for the device. It is a 31 gauge needle with a 0.25mm diameter.

Unique to this design:

- This design features a bowl shaped mouthpiece
- It features a plastic ring that stays in place and prevents too far of insertion
- This device would be inserted straight into the trachea (perpendicular to it)

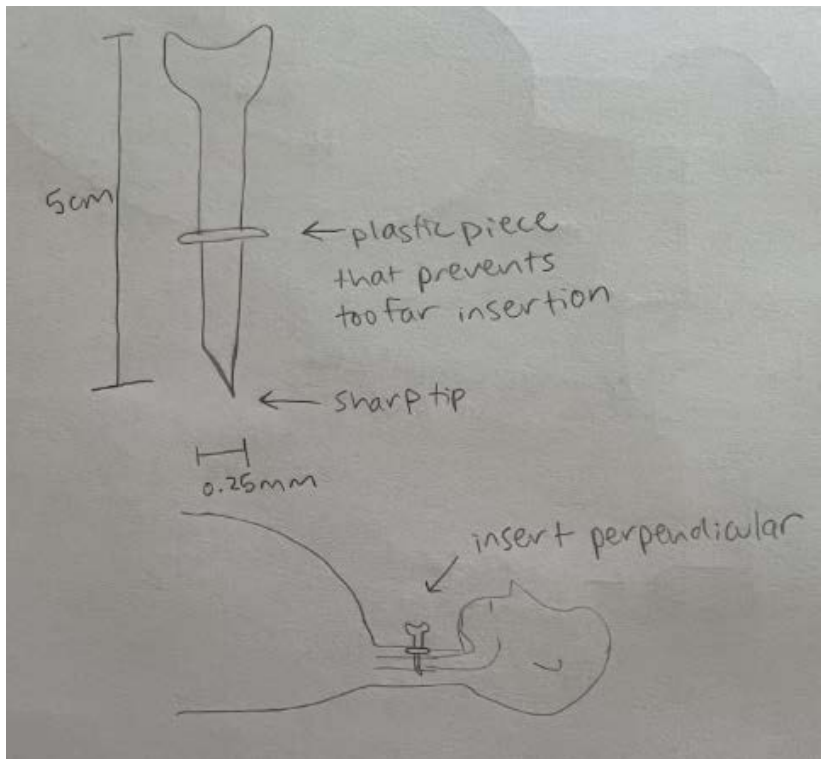

**Conclusions/action items:**

Tonight I will be meeting with my team. We will each bring 2-3 initial design ideas to the meeting and from there we will narrow the designs down to our top 3 or 4 designs. These designs will then be included in the design matrix which will be used to determine the initial prototype design. I also need to research the anatomy of the trachea.





**9/27/23 Idea 3**

---

**Title:** 9/27/23 Idea 3**Date:** 9/27/23**Content by:** Annika Rossebo**Present:** Annika Rossebo**Goals:** My goal is to document one of my 3 initial designs.**Content:**Design components for all 3 of my designs:

- Made completely from plastic
- Sharp, beveled tip to pierce skin and trachea
- Some sort of marking or plastic piece to stop the user from inserting the device too far and risking puncturing the esophagus
- 0.25mm diameter
- 5cm device length
- This design is based on the size of the "3/10 mL U100 insulin single use only syringe" that the client uses as a prototype for the device. It is a 31 gauge needle with a 0.25mm diameter.

Unique to this design:

- This design is unique because the end piece of the device can interface with a bag valve mask (BVM)
- The idea behind the BVM interface is so EMS can leave the airway in if it stays patent
- Like idea 2, this device features a plastic ring that aims to prevent too far of insertion
- The right side of the image demonstrates how this device could be used

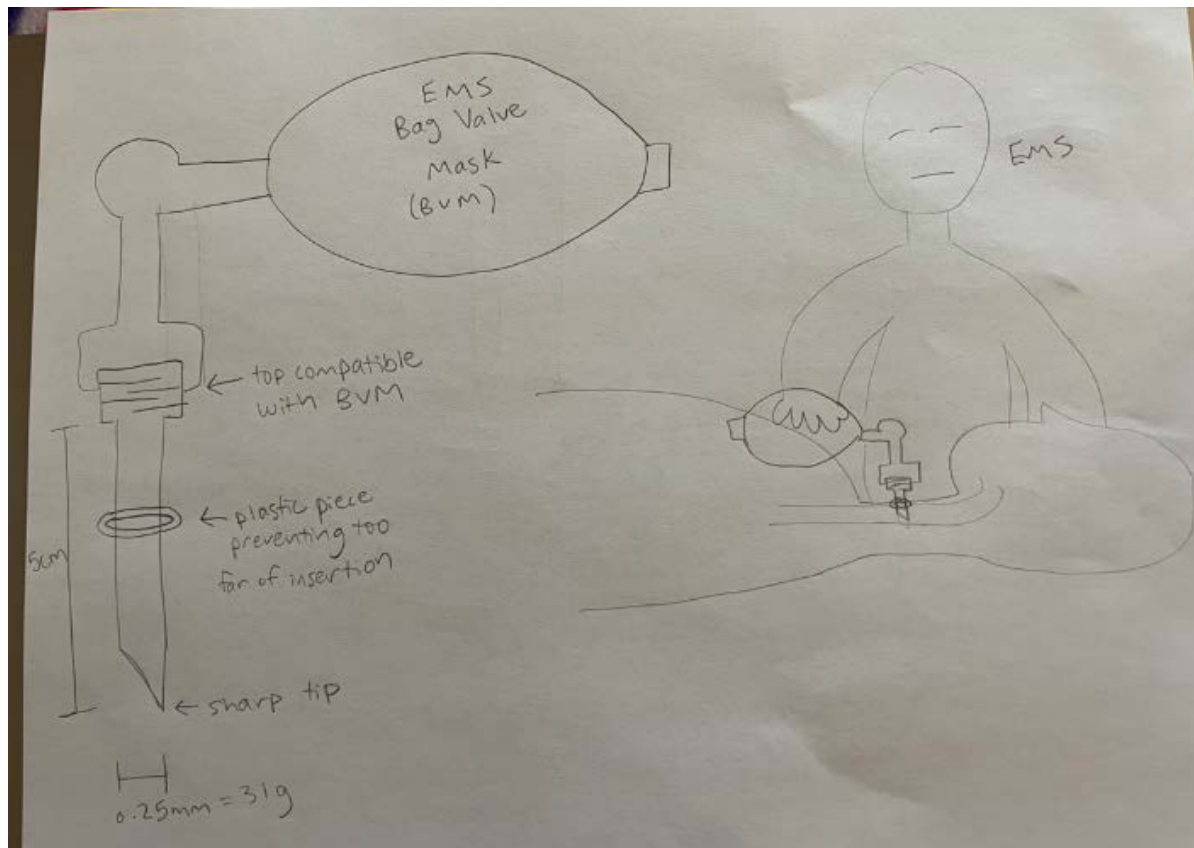



**Conclusions/action items:**

Tonight I will be meeting with my team. We will each bring 2-3 initial design ideas to the meeting and from there we will narrow the designs down to our top 3 or 4 designs. These designs will then be included in the design matrix which will be used to determine the initial prototype design. I also need to research the anatomy of the trachea.



## 10/12/23 Design/Manual Considerations

ANNIKA ROSSEBO - Oct 12, 2023, 2:19 PM CDT

**Title:** 10/12/23 Design/Manual Considerations

**Date:** 10/12/23

**Content by:** Annika Rossebo

**Present:** Annika Rossebo

**Goals:** My goal is to document ideas and considerations for our future designs or manuals.

**Content:**

When considering the ethics of this project, I was thinking about how anyone should be able to use this device. One consideration that comes to mind is language. People who do not speak english should be able to utilize this device. I think about how AEDs utilize clear diagrams or universal symbols to hopefully aid in ease of use. An example of these symbols and diagrams are below:



1. AED Defibrillator for Business | Office | Workplace. American AED. Accessed October 12, 2023. <https://americanaed.com/aed-solutions/business-aed-package/>

### Conclusions/action items:

If the device becomes mass marketed, it should be marketed to everyone, including non-english speakers. It would be important to consider choosing symbols or diagrams that can clearly demonstrate how the device is to be used. I will include this information in the ethical considerations section of the discussion and will work on my other parts of the preliminary report. I will also fill out feedback fruits.



## 10/12/23 Design Interface with BVM

ANNIKA ROSSEBO - Oct 12, 2023, 3:32 PM CDT

**Title:** 10/12/23 Design Interface with BVM

**Date:** 10/12/23

**Content by:** Annika Rossebo

**Present:** Annika Rossebo

**Goals:** My goal is to document the image I made that shows how the proposed final design would interface with a BVM.

**Content:**

I created this image showing how the proposed final design would interface with the human body and the bag valve mask. I thought it would help to illustrate our ideas visually.



Here are my sources for the images:

A. Limited, "black and white vector sketch for a portrait of a young man's profile Stock Photo - Alamy." Accessed: Oct. 12, 2023. [Online]. Available: <https://www.alamy.com/black-and-white-vector-sketch-for-a-portrait-of-a-young-mans-profile-image459485225.html>

"Amazon.com: CPR Training Bag Valve Mask (BVM) ADULT/CHILD in Mesh Bag, BVM-3081-001 : Industrial & Scientific." Accessed: Oct. 12, 2023. [Online]. Available: <https://www.amazon.com/Training-Plastic-MCR-Medical-BVM-3081-001/dp/B00GABWX8K>

**Conclusions/action items:**

I will include this image in the preliminary report and will work on my other parts of the preliminary report. I will also fill out feedback fruits.



## Tong Lecture 11/10

---

ANNIKA ROSSEBO - Nov 10, 2023, 12:31 PM CST

**Title:** Tong Lecture 11/10

**Date:** 11/10

**Content by:** Annika Rossebo

**Present:** Annika Rossebo

**Goals:** My goal is to take notes on the Tong Lecture

**Content:**

- Dr. Travelle Ellis, MD PhD
- Undergrad at University of Pittsburg
- MSTP at UW Madison
  - Did not match for residency
- Currently Health Equity Director at Exact Sciences
- Passionate about explaining complicated science to people who may not understand it
- Advice
  - 1. Find your people
    - Each of us are here because of someone else, but there is also someone behind us. Keep the door open
  - 2. Do things that scare you
    - If things are too comfortable, they're too easy
  - 3. Laugh until you cry, cry until you laugh
- Be inspired by OUR story

**Conclusions/action items:**

Recap only the most significant findings and/or action items resulting from the entry.



## 9/20/2023--Code of Federal Regulations for Anesthesiology Devices

KATERINA SMEREKA - Sep 28, 2023, 3:36 PM CDT

**Title:** FDA Regulations on Anesthesiology Devices

**Date:** Sept 28, 2023

**Content by:** Katerina

**Present:** N/A

**Goals:** Underscore what class of device the FDA would claim our device would be

**Content:**

Section 868 Anesthesiology Devices, Subpart G, therapeutic devices, sec 5095, Retrograde intubation device

ID: A retrograde intubation device is a prescription device used to perform retrograde intubation via the cricothyroid membrane. May contain for use with guidewires, catheters and needles, syringes.

Considered Class II (Special controls)

Special Controls include:

-nonclinical performance that proves: wire guide tensile strength, flexure, catheter tensile strength, catheter kink radius testing, compatibility of device that interact with connection and transfer fluids, dimensional validation, accuracy testing of markings

-Performance data must support the shelf life of the device and continued sterility, packaging and functionality

-Must prove to be biocompatible

-Labeling must include:

-instructions for use and identify the minimum compatible size of endotracheal tube

**Conclusions/action items:**

**This seems like a plausible description of our device. We should follow these codes for standards and specifications of the device.**



## 9/20/2023--Code of Federal Regulations for Anesthesiology Devices, Needles

---

KATERINA SMEREKA - Sep 28, 2023, 3:39 PM CDT

**Title:** FDA Regulations on Anesthesiology Devices

**Date:** Sept 28, 2023

**Content by:** Katerina

**Present:** N/A

**Goals:** Underscore what class of device the FDA would claim our device would be

**Content:**

Section 868 Anesthesiology Devices, Subpart G, therapeutic devices, sec 5090, Emergency airway needle

ID: An emergency airway needle is a device intended to puncture a patient's cricothyroid membrane to provide an emergency airway during upper airway obstruction/

Classification: Class II

**Conclusions/action items:**

**This could be a classification of our device. Because our device has multiple functions, I think we should also apply to these standards because the device needs to puncture and provide an airway**



## 9/20/2023--Code of Federal Regulations for Otolaryngeal Devices

---

KATERINA SMEREKA - Sep 28, 2023, 3:46 PM CDT

**Title:** FDA Regulations on Anesthesiology Devices

**Date:** Sept 28, 2023

**Content by:** Katerina

**Present:** N/A

**Goals:** Underscore what class of device the FDA would claim our device would be

**Content:**

Section 874 Ear, Nose and Throat Devices, Subpart E Surgical Devices, Sec 4420, Ear, Nose and Throat Manual Surgical Instrument

ID: An ear, nose and throat manual surgical instrument is intended for use in surgical procedures to examine or treat the bronchus, esophagus, trachea, larynx. This includes the esophageal dilator, tracheal bistour, tracheal dilator, tracheal hook, tonsil guillotine, etc

Classification: Class I

**Conclusions/action items:**

**I think I got confused. While this device is used for the ear, nose and throat, I do not think this classification fits our device description. Our device should have stricter classifications than general controls, class I. I will have to look at a different section to better describe our device.**



## 9/20/2023--Surgical Anatomy of Cricothyroid Membrane w Reference

KATERINA SMEREKA - Sep 28, 2023, 9:36 PM CDT

**Title:** Surgical Anatomy of Cricothyroid Membrane with Reference to Airway Surgeries in North Indian Population: A Cadaveric Study

**Date:** Sept 20, 2023

**Content by:** Katerina

**Present:** N/A

**Goals:** Underscore the numerical value that the depth needed to achieve by our device

**Content:**

- cricothyroid space is the space that extends between the arch of the cricoid cartilage below and the inferior edge of the thyroid lamina above
- cricothyroid membrane covers the space between the cricoid and thyroid
- orotracheal intubation is preferred method of securing airway
- size and position of cricothyroid membrane is variable depending on racial characteristics of the individual
- purpose of the current paper was to measure the dimensions of the cricothyroid membrane and depth of subglottic space in the adult north Indian population
- larynges removed from the hyoid till the second tracheal ring
- soft tissues were removed
- measured upper transverse width
- middle transverse width
- lower transverse width
- height of the membrane
- thickness of the membrane
- depth of the subglottic space
- subglottic depth of female larynges were 17.24mm +/- 2.09
- subglottic depth of male larynges were 21.94 +/- 2.93 mm
- ET tubes ranging from 3.0 to 5.0 in females and 4.0 to 6.0 in males are suggested

**Conclusions/action items:**

**Very straight forward article. I am curious in looking into endotracheal tube sizing and what the numbers represent. Very thorough article to help with dimensions of our device.**





## 9/20/2023--Cricothyroidotomy

KATERINA SMEREKA - Sep 28, 2023, 9:47 PM CDT

**Title:** Cricothyroidotomy

**Date:** Sept 20, 2023

**Content by:** Katerina

**Present:** N/A

**Goals:** Underscore the typical procedure of cricothyroidotomys to better understand the stress and steps our device will need to be equipped for

**Content:**

- thyroid gland is covered by the visceral fascia, which attaches it firmly to the laryngoskeleton
- anterior suspensory ligament extends from the superior-medial aspect of each thyroid lobe to the cricoid and thyroid cartilage
- posteromedial aspect of the gland is attached to the side of the cricoid cartilage, first and second tracheal ring by the posterior suspensory ligament
- this attachment is responsible for the movement of the thyroid gland and related structures during swallowing
- typically need antiseptic solution
- lidocaine
- sterile materials
- angiographic catheter
- syringe
- patient must be supine with the neck in the neutral position and medical personnel standing on patient's right side
- with dominant hand, make a midline vertical incision, 3cm long, skin deep over the membrane
- palpate the cricothyroid membrane through the incision, using the index of the nondominant hand
- make a horizontal stab incision through the membrane
- dilate the incision vertically
- insert tracheotomy tube and rotate it 90 degrees and insert caudally
- lock it into place and attach bag-valve mask

complications include:

- bleeding
- subcutaneous emphysema
- obstruction
- aspiration
- vocal cord injury
- pneumothorax
- dysphonia
- infections
- hematoma
- scarring
- laryngeal stenosis

**Conclusions/action items:**

Very insightful on the procedure. It seems like a lot of steps though. Maybe takes a lot longer than it really should or is healthy to do. Maybe our client wants a simpler procedure that is quicker to establish the airway



## 9/20/2023--Prehospital Trauma Scene and Transport Times

---

KATERINA SMEREKA - Sep 28, 2023, 9:54 PM CDT

**Title:** Prehospital Trauma Scene and Transport Times

**Date:** Sept 20, 2023

**Content by:** Katerina

**Present:** N/A

**Goals:** Underscore how long it takes EMS on average to arrive on the scene

**Content:**

- studies have shown that for each additional minute of prehospital time, the risk of dying increases by 5%
- one study examined 164,000 trauma registry cases, prolong scene time was associated with increased mortality among patients with hypotension, penetrating trauma and flail chest
- purpose of this study was to examine prehospital time patterns to better understand scene and transport time practices among patients
- study conducted across five counties with advanced life support EMS agencies over a five year period
- mixed urban and rural areas of north carolina
- included blunt and penetrating trauma patients of all ages who were transported directly from the scene to a level I or level II trauma center by ground ambulance
- overall, mean scene time was 14.2 minutes
- 90th percentile overall scene time was 25 minutes
- scene time was 10 mins or less in 35% of encounters
- penetrating trauma scene time for adult patients was significantly greater than in pediatric patients
- mean transport time was 17.5 minutes
- adult blunt trauma transport time was comparable to pediatric blunt trauma transport time
- 10 minute time scene goal is only achieved in only 1/3 of encounters

**Conclusions/action items:**

This makes me so sad. It definitely is really hard to get to emergency scenes quickly, but I guess I didn't realize how slow EMS can be. Definitely highlights an importance of our device.



## **2023/9/10--Ultrasound for airway management: An evidence-based review for the emergency clinician**

---

**Title: Ultrasound for airway management: An evidence-based review for the emergency clinician****Date:** Sept 10, 2023**Content by:** Katerina**Present:** N/A**Goals:** Understand the emergency cricothyroidotomy procedure**Content:**

- Endotracheal intubation is a commonly performed procedure in emergency medicine
  - 350, 000 cases occurring each year in US alone
- 10% of cases requiring emergency airway management are considered difficult
- Ultrasound has been emerging for a potential modality for airway assessment and management
- Point of care ultrasound (POCUS) is used for diagnosis and imaging guide
- POCUS may play a role in identifying patients with a difficult airway prior to a procedural sedation for intubation
- POCUS can also localize the cricothyroid membrane in prep for a 'cannot intubate, cannot ventilate' situation
- This article examines the use of ultrasound for airway management
- LITERATURE REVIEW
  - Used keywords
    - Ultrasound
    - Airway
    - Intubation
    - Cricothyrotomy
    - Cricothyroidotomy
- In clinical practice, the initial approach to airway evaluation starts with bedside assessments, to predict difficult airways
- Use may be limited in ED because of neck immobility, inability to follow commands or concurrent use of non-invasive ventilation
- Mallampati score is only 51% sensitive for predicting difficult laryngoscopy
- This led researchers to evaluate the role of POCUS as a potential tool for airway assessment
- Increased soft tissue depths associates with more difficult intubations
- One study found that the distance from the skin to the vocal cords and from the skin to the suprasternal notch were both highly predictive of difficult intubations
- Another found that the distance from the skin to the thyrohyoid membrane was predictive of difficult intubations and recommends a threshold of greater than 2.8cm to identify difficult intubations
  - Found that POCUS also outperformed standard clinical decision rules
- POCUS can also be used to evaluate for subglottic stenosis and predict proper ETT size
- POCUS is highly accurate for measuring airway size when compared with computed tomography and magnetic resonance imaging

- Not a single best approach to assessment of the difficult airway, clinicians should consider using pOCUS to assess for higher risk features when predicting difficult intubations

#### ENDED UP GETTING IRRELEVANT AND FRAYED FROM EMERGENCY CRICOTHYROIDOTOMY

- Cricothyroidotomy can be a life-saving procedure in 'cannot intubate, cannot ventilate' situations, which can lead to disastrous consequences
- This was taught using surface landmarks to identify the cricothyroid membrane
- The first pass success rates with the **landmark technique** are low, as low as 36% among anesthesiologists
- Anesthesiologist were able to successfully identify the cricothyroid membrane with anatomical landmarks 71% of the time in non-obese women and 39% of the time with obese women
- Ultrasound has been demonstrated to be superior for identifying the cricothyroid membrane
- One study demonstrated that the ultrasound guidance during cricothyroidotomy resulted in a five-fold improvement in correct tube placement among subjects with difficult to palpate anatomy
- In order to identify appropriate placement in the transverse plane, a linear probe is first placed on the midline of the neck at approximately the cricoid cartilage, with the probe indicator to the patient's right
- Probe is slowly advanced cephalad until the thyroid cartilage is visualized as a hyperechoic, triangular structure
- Transducer is moved caudally to visualize the cricothyroid membrane as a hyperechoic white line with reverberation air artifact posteriorly
- To confirm visualization, the probe is advanced further caudally until the cricoid cartilage is visualized
- The probe can then be moved cephalad to again visualize the cricothyroid membrane
- A skin marker can be used to mark the midline of the cricothyroid membrane above and below the probe if the procedure is being performed prior to intubation
- Alternatively, dynamic guidance can be performed by inserting a needle through the cricothyroid membrane under ultrasound visualization using Seldinger technique
- Another technique is the longitudinal technique
- Linear probe is first placed at the level of the cricoid cartilage in the transverse orientation
- Once the cricoid cartilage is identified, the probe is then rotated 90 degrees counterclockwise, so the airway is visualized in the longitudinal axis
- Tracheal rings will be visualized as a series of hypoechoic structures anterior to a white, hyperechoic line
- The transducer is moved cephalad to identify the thyroid cartilage
- Then, they insert linear, metallic object like a paper clip or needle under the probe to create a shadow over the membrane
- Then a horizontal incision is made through the membrane, just medial to the probe
- The scalpel is rotated 90 degrees, the probe is released and a gum elastic bougie is inserted into the incision site
- ETT is inserted into the trachea over the bougie
- This technique was successful in 20 of 21 cadavers with a median time to insertion of 26 seconds
- Studies suggest EM physicians are able to rapidly identify the cricothyroid membrane with ultrasound, reasonable to mark the cricothyroid membrane prior to intubation among patients with anticipated difficult airways
- If endotracheal intubation fails, the location for surgical cricothyroidotomy has already been marked, allowing the physician to proceed with minimal delay

#### Conclusions/action items:

Didn't really anticipate for things to be so ultrasound focused, but it was still pretty insightful!! I am curious and going to dig deeper on the anatomical landmarks that are useful for this type of procedure



## **2023/9/10--Retention of emergency cricothyroid skills: A multicenter randomized controlled trial**

---

**Title: Retention of emergency cricothyroid skills: A multicenter randomized controlled trial****Date:** Sept 10, 2023**Content by:** Katerina**Present:** N/A**Goals:** Understand who performs emergency cricothyroid procedures**Content:**

- Mastered by emergency physicians and anesthesiologists
- Time is essential to prevent brain damage and death, in compromised airway situations
- Failure rate of 25%
- Indicates the need for structured training to acquire and maintain an adequate level of competency to minimize preventable harm and increase patient safety
- Study aims to determine the retention of skills in emergency cricothyroidotomy by exploring the loss of technical skills at 1, 3 and 6 months after novices received structured SBT in the procedure
- Medical students with no prior experience with emergency cricothyroidotomy were invited
- Participation was voluntary, participants were invited by email, face-to-face meetings and social media posts
- No compensation was offered
- Participants were randomized into one of three retention groups using block randomization in blocks of 9
- participants received theoretical and hands-on training in emergency cricothyroidotomy in individual sessions by an instructor
- Training was based on the standardized rapid four-step technique course
- Evidence-based, structured assessment tool of technical skills performance has been developed to evaluate physicians skills in RFST procedure and a pass/fail standard has been set
- Recordings were evaluated by two experienced raters
- Raters were blinded and did not have any access to any information regarding the participants
- Recordings were blinded and tagged with a unique identification number and were presented to the raters in a random order so that the raters were also blinded to whether recordings were from end-of-training or retention tests
- Found that technical skills performance decreased more as time passed even though this was only reached statistical significance when comparing the differences between retention performances of the 1 and 6 months groups
- This rapid loss of skills in emergency cricothyroidotomy procedure substantiates the importance of retraining skills that are performed infrequently in the clinic to ensure that adequate skills are maintained
- Most of the literature agreed w the study and found the dip in loss of skill between 2 weeks and 14 months
- Other studies found that anesthesiologist skills in EM CT overall were maintained at 6 and 12 months although there were indications of skills deterioration
- This is different from our findings but might be a result of the fact that anesthesiologist are exposed to the theory and tools more than nova medical students

**Conclusions/action items:**

Leads me to believe that we will be making a device for physicians and EMTs and people who are trained. Need to consider that when designing and ergonomics





# 2023/9/10--Cricothyroidotomy-The Emergency Surgical Airway

---

**Title:****Cricothyroidotomy-The Emergency Surgical Airway****Date:** Sept 10, 2023**Content by:** Katerina**Present:** N/A**Goals:** Understand the emergency cricothyroidotomy procedure**Content:**

- Studies have shown that initial attempts to create a surgical airway are often made by an anesthesiologist or NEUROsurgeon
- Procedure is high-risk, low-frequency one that, even in trained hands, is too often performed unsuccessfully
- More than half of all initial attempts by anesthetists fail
- Rapid Four-Step Technique (RFST) is very fast emergency cricothyroidotomy procedure that involves minimal demand for surgical aptitude, as no dissection is required
- Scalpel is introduced via a horizontal stab incision directly through the cricothyroid membrane into the trachea and an endotracheal tube is introduced into the trachea, aided by a hook
- <https://onlinelibrary-wiley-com.ezproxy.library.wisc.edu/doi/10.1002/hed.24392>

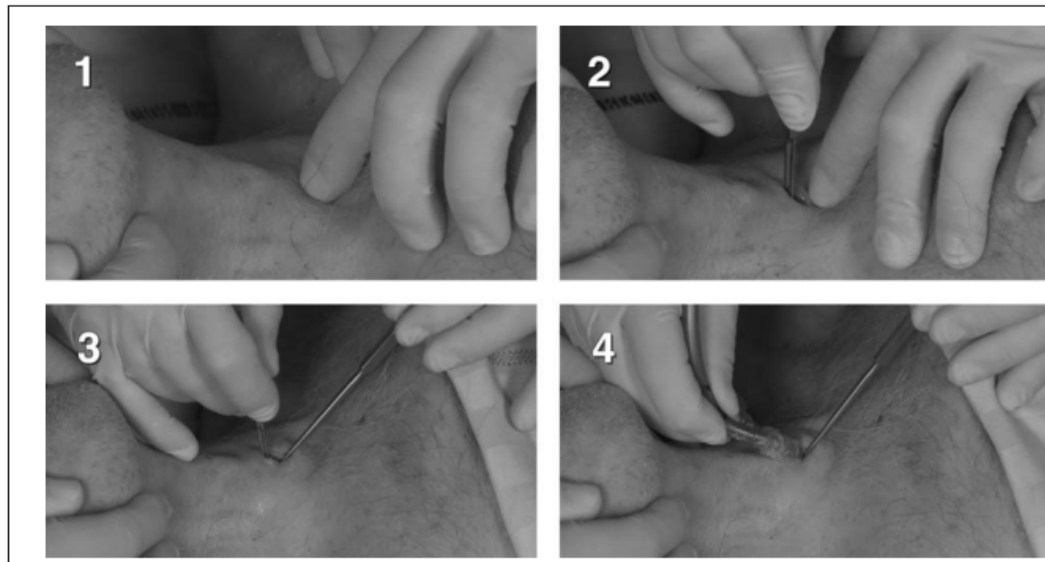

- Technique involves 4 steps
- Traditional tracheotomy used in elective cases involves surgical access through the lower part of the anterior neck, through a thicker layer of subcutaneous fat and past potential sources of bleeding, such as the thyroid gland
- Cricothyroidotomy, utilizes the superficial location of the cricothyroid membrane in the middle of the anterior neck with its thin subcutaneous fat layer to access the airway
- The membrane consists of a dense band of fibroelastic tissue and spans the opening between the cricoid and the thyroid cartilage

- RFST has 2 avoidable pitfalls
  - Essential to slide the hook parallel to the blade of the scalpel until the posterior wall of the subglottic larynx at the level of the cricoid cartilage is felt before rotating the hook and applying traction anteriorly and inferiorly
  - Blunt end of the hook can't damage the posterior wall and this procedure ensures that the hook catches the mucosal lining as well as the anterior part of the cricoid cartilage
  - Eliminates the possibility of placing the tube in a false passage

**Conclusions/action items:**

Very insightful. I'm curious if our client wants us to replace the scalpel portion. Or if our device needs to have the scalpel and the intubation tube in it



## 10/10/2023--Biocompatible Plastics in the Medical Field

---

KATERINA SMEREKA - Oct 13, 2023, 11:29 AM CDT

**Title: Biocompatible Plastics in the Medical Field**

**Date: 10/10/2023**

**By: Katerina**

**Goal: Understand the current plastics out there that are used in the medical field**

**Citation:**

[ "Biocompatible Plastics in the Medical Industry - Despatch." Accessed: Oct. 13, 2023. [Online]. Available:  
1 <https://www.despatch.com/blog/biocompatible-plastics-in-the-medical-industry/>  
]

**Content:**

- reserachers expect the biocompatible plastic market to rise considerably during 2022 and 2028
- plastics offer numerous advantages over metal
  - like thier strength, malleability and longeviity
- offer better corrosion resistance from disinfectants
- some biocompatible plastics include
  - PS
  - PP
  - PV
  - PE
  - PU
  - PC
  - PET
  - PEEK
- found in a wide variety of medical devices, instruments and components
  - implant devices
  - surface devices
  - externally communicating devices
- PEEK is the hottest biocompatible plastic on the market
  - high performnce
  - versitile, safe

**Conclusions:**

**Not very helpful because they didn't go in depth on how each plastic is used. Need to keep looking to see what is being used in endotracheal tubes and other similar devices to ours.**



## 10/10/2023--PVC Properties

---

KATERINA SMEREKA - Oct 13, 2023, 11:37 AM CDT

**Title:** Polyvinyl Chloride (PVC)

**Date:** October 10, 2023

**By:** Katerina

**Goals:** Underscore the material properties of medical grade pvc

**Citation:**

- [ "PVC Properties," Vinidex Pty Ltd. Accessed: Oct. 13, 2023. [Online]. Available:  
1 <https://www.vinidex.com.au/technical-resources/material-properties/pvc-properties/>  
]

**Content:**

compounds with the greatest short term and long term strengths, those with no plasticisers and the minimum of compounding ingredients

- known as UPVC
- other resins may be added to improve impact resistance
- UPVC:
  - hard and rigid, ultimate tensile stress of approx 52MPa, very resistant to chemicals
- PVC-M:
  - rigid and has improved toughness, like impact
  - elastic modulus, yield stress and ultimate tensile strength are lower than PVCU
  - properties depend on type and amount of modifier used
- PVC, plasticized
  - less rigid
  - high impact strength
  - easier to mold
  -
- general properties
  - used in pipe manufacture

• **Conclusions:**

**The website began to disclose material properties of PVC piping, which I knew is not helpful for the conceptualization of materials for our device, so I stopped taking notes.**



## 10/10/2023--Gastric Perforation

---

KATERINA SMEREKA - Oct 13, 2023, 11:48 AM CDT

Title: Gastric Perforation: A Case Study

Date: 10/10/2023

By: Katerina

Goal: Understand complications of the heimlich

Citation: C.-M. Chao, C.-C. Lai, and C.-K. Tan, "Gastric Perforation after Heimlich Maneuver," *Am. J. Med.*, vol. 125, no. 6, pp. e7–e8, Jun. 2012, doi: 10.1016/j.amjmed.2012.02.008.

Content:

- heimlich is a life saving procedure when someone chokes on a foreign body
- rare complication have been reported
- study presents a case of gastric perforation following the heimlich
- 59 yo suffered from an airway obstruction while eating breakfast
  - immediate loss of consciousness
- medical history of nasopharyngeal cancer and had undergone radiotherapy
- impaired swallowing function
- EMT arrived and performed heimlich, then patient went to cardiac arrest and CPR was performed
- food debris was removed at the ED and after intubation, the patient was recovered
- the radiography showed massive subphrenic free air
- after a laparotomy, there were tears in gastric wall
- other complications include rib fracture, diaphragm rupture, acute thrombosis
- gastric perforation caused by the abdominal thrusts
- 

Conclusion:

I found this to be very insightful on the harms of the heimlich. It makes sense why gastric perforation is such a common harm. I'm curious on the prevalence of it





## 10/10/2023--Study of Survival Rate After CPR in Hospitals

---

KATERINA SMEREKA - Oct 13, 2023, 2:54 PM CDT

**Title:** Study of Survival Rate After CPR in Hospitals of Kermanshah in 2013

**Date:** 10/13/2023

**Content by:** Katerina

**Present:** N/A

**Goals:** Understand how effective CPR is

**Content:**

- after cpr, the follow up survival rate is the most important
- this study aimed at determining follow up results after CPR
- 320 cases were examined
- data was collected using a researcher-made information form with content and face validity and reliability of  $r=0.79$
- initial success rate is 15.3%
- ultimate success rate/discharge rate was 10/6%
- 6 month success rate after resuscitation was 8.78% than those who were discharged alive
- no statistical differences between differences in age group
- recommended to increase the medical-nursing knowledge and technique for personnel in the evening and night shifts
- appropriate dissemination of health care staff in working shifts should be done to increase the success rate of CPR procedure

**Conclusions/action items:**

Very insightful. The low success rate gives more clinical evidence as to why our product is important





## 10/10/2023--Accuracy of indentifying the cricothyroid membrane by anesthesia trainees

KATERINA SMEREKA - Oct 13, 2023, 3:07 PM CDT

**Title:** Accuracy of identifying the cricothyroid membrane

**Date:** October 10, 2023

**Content by:** Kat

**Present:** N/A

**Goals:** understand how accurate people can identify anatomical landmarks

**Content:**

**aim:** determine the rate of successful identification of the cricoid membrane by anesthesia residents and staff at a Canadian institution

- healthy adult volunteer subjects were positioned supine with their necks placed in neutral position
- 12 subjects, half obese
- equal number of male and female
- staff and resident participants were allowed to palpate subjects, only one attempt per subject
- ultrasonography was used to identify the superior and inferior borders
- identification was considered correct if the mark was between 0.5cm of midline
- 186 identifications
- success rate were as follows:

rates for the subgroups were as follows: non-obese men 72% (95% confidence interval [CI] 59 to 85%); obese men 39% (95% CI 26 to 54%); non-obese women 24% (95% CI 12 to 36%); obese women 35% (95% CI 21 to 49%).

**Conclusions/action items:**

Very surprising. This indicates that when our device reaches the market, we should include a picture to help find anatomical landmarks.



## 11/7/2023-It's in the Bag:Tidal Volumes of BVM

---

KATERINA SMEREKA - Nov 09, 2023, 5:56 PM CST

**Title:** It's in the Bag: Tidal Volumes in Adult and Pediatric Bag Valve Masks

**Date:** 11/7/2023

**Content by:** Katerina

**Present:** N/A

**Goals:** Understand how much air is expelled out of a bvm

**Content:**

- BVM is used by all levels of health care professionals
- most bvm users focus on optimizing the patient's position, securing mask and frequency of ventilations
- however, there might be still harm to the patient
- literature has discussed that the tidal volumes typically delivered by the adult BVM is higher than recommended
- this study aimed to measure and compare the ventilation parameters delivered in adult and pediatric bvm ventilators
- used a RespiTrainer Advance adult mannequin
- Healthcare providers were directed to manually ventilate an intubated mannequin for two minutes using adult and pediatric bvm
- measured tidal volume, minute ventilation, peak pressure and respiration rate
- mean adult tidal volume was 807.7ml
- mean pediatric tidal volume was 630.7
- both exceeded the upper threshold of 560mL of tidal volume necessary for lung protective ventilation
- the adult BVM exceeded this threshold by 44.2%
- the mean peak pressure measured in the adult BVM was 17 cmH<sub>2</sub>O
- mean minute ventilation for the adult bvm was 11.6L
- 8.8 minute ventilation for pediatric
- 93% of participants exceeded the upper threshold for tidal volumes
- concluded that pediatric bvm provided more consistent and appropriate ventilation parameters for adult than the adult bvm
- highlights the potential dangers in using an adult bvm

**Conclusions/action items:**

For my mathematical calculations, I will use a minute ventilation of 11.6L/min as my air velocity rate



**11/7/2023--EMS Pocket Mask**

---

**Title:** EMS Pocket Mask

**Date:** 11/7/2023

**Content by:** Katerina

**Present:** N/A

**Goals:** Understand the radius of the outlet valve of the BVM that connects to the CPAP/resuscitation mask

**Content:**



mask is equipped with standard 22mm fitting, allows th attachment of any standard resuscitation device

all masks come standard with an oxygen inlet which can be left blocked if not required

**Conclusions/action items:**

Going to corroborate the 22mm diameter with other sources to ensure this is a universally accepted value





## 11/7/2023--LSP Gooseneck BVM

KATERINA SMEREKA - Nov 09, 2023, 6:03 PM CST

**Title:** LSP Gooseneck

**Date:** 11/7/2023

**Content by:** Katerina

**Present:** N/A

**Goals:** Understand the radius of the outlet valve of the BVM that connects to the CPAP/resuscitation mask

**Content:**



has a disposable mask, featuring a 3 foot circuit between bag and mask

allows for resuscitation in confined spaces or in ambulance

Specs:

Bag volume: 1448ml

Patient connection: 22mm OD, 15mm ID

Use thermoplastic rubber, use a packaging made of tamper-proof polybag

**Conclusions/action items:**

**Very reassuring that they also used a 22mm diameter. Very helpful that they gave a inner diameter as well.**



# 11/7/2023-BVM patent

KATERINA SMEREKA - Nov 09, 2023, 6:02 PM CST

**Title:** BVM patent

**Date:** 11/7/2023

**Content by:** Katerina

**Present:** N/A

**Goals:** Understand the radius of the outlet valve of the BVM that connects to the CPAP/resuscitation mask

**Content:**

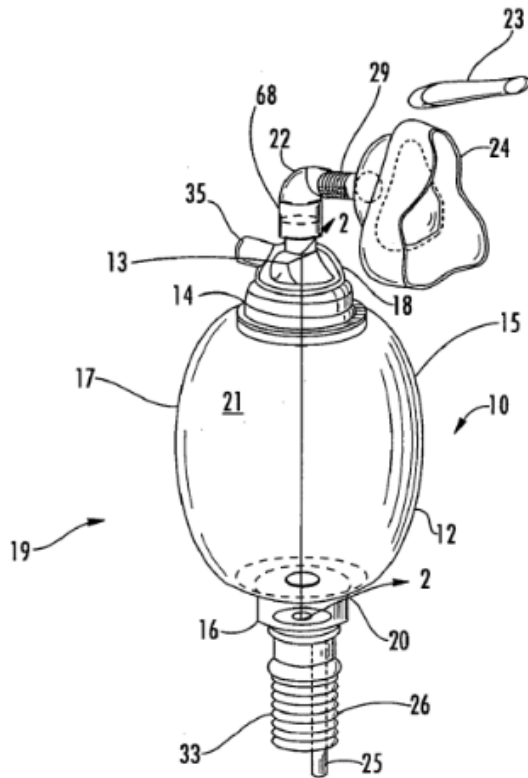

**Conclusions/action items:**

So sad that they did not disclose any dimensions in the patent. Will have to find more devices on the market





## 11/7/2023-CPAP Mask valve

---

KATERINA SMEREKA - Nov 09, 2023, 8:38 PM CST

**Title:** CPAP valve

**Date:** 11/7/2023

**Content by:** Katerina

**Present:** N/A

**Goals:** Understand the radius of the outlet valve of the BVM that connects to the CPAP/resuscitation mask

**Content:**



prevents backflow of oxygen and water into cpap machine

22mm connector that fits on the outlet port of a Bipap or cpap

minimum operating pressure is 2cmH<sub>2</sub>O

**Conclusions/action items:**

Reassuring that they also said that their connector is 22mm



# 11/7/2023--Updated Hole Puncher Design

---

**Title: Updated Hole Puncher****Date:** 11/7/2023**Content by:** Katerina**Present:** N/A**Goals:** Underscore edits made to the hole puncher design**Content:**

-Since the average height of the cricothyroid membrane is  $7.71 \pm 1.38\text{mm}$  for males and  $6.41 \pm 1.28\text{mm}$  in females, our device needs to reflect these values

-as well, a bvm outlet valve has an outer diameter of 22mm and our device needs to be able to fit the bvm outlet hole

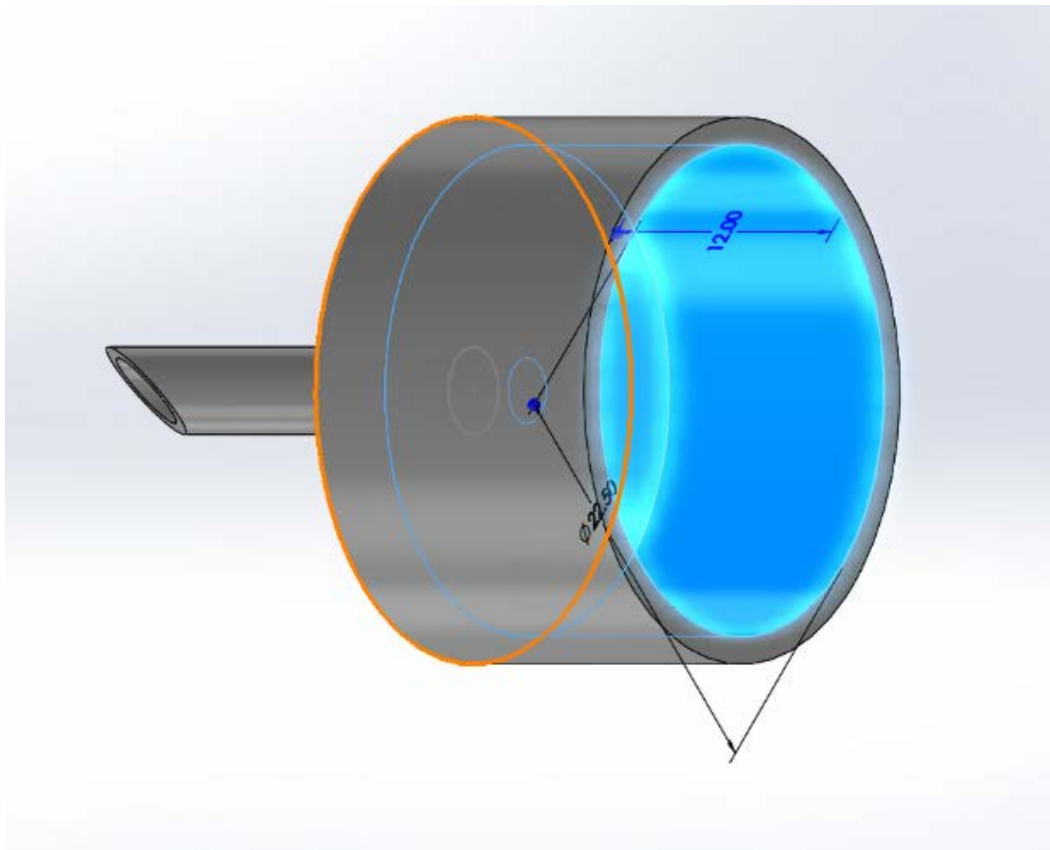

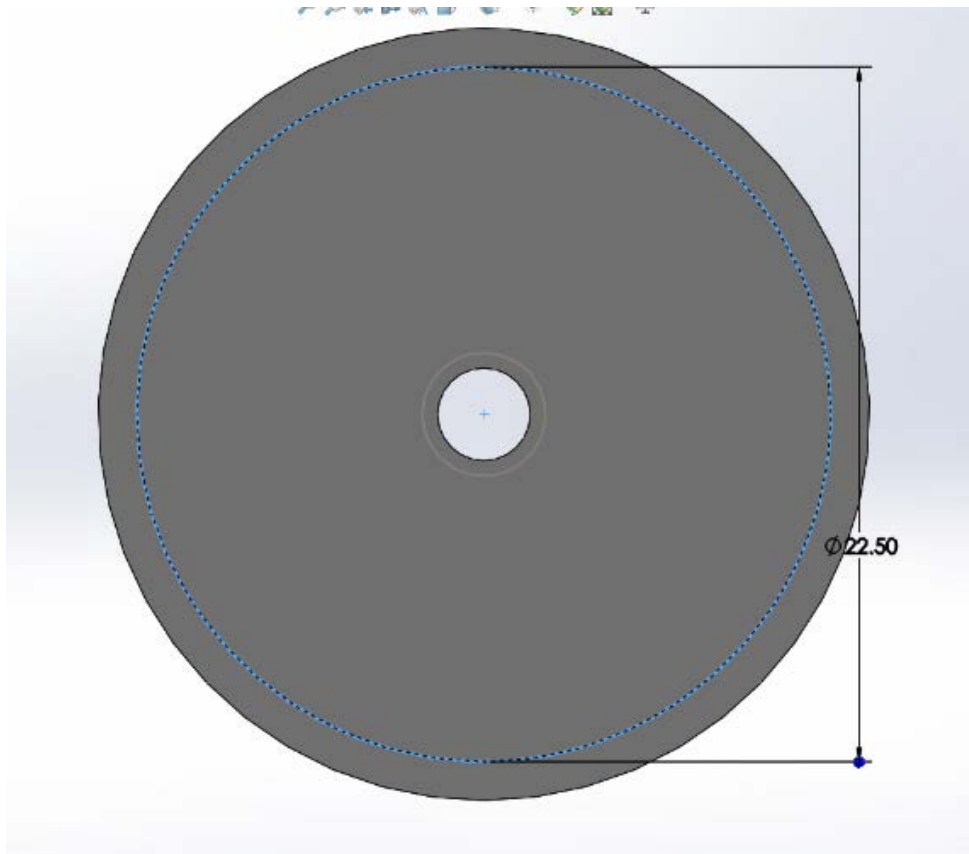

The main edit I did was widen the cut in order to fit the bvm mask; it was originally as 22mm, which would cause modulation fit issues.

**Conclusions/action items:**

**Need to fabricate or 3D print and test the new size.**



## 11/7/2023--Mathematically Calculating Device Air Velocity

KATERINA SMEREKA - Nov 07, 2023, 2:23 PM CST

**Title:** Mathematically Calculating Device Air Velocity

**Date:** 11/7/2023

**Content by:** Katerina

**Present:** N/A

**Goals:** Now that we have set our device radius, we need to estimate how much air is delivered with our device

**Content:**

$$Q_{BVM} = Q_{device}$$

$$\langle V_{BVM} \rangle A_{BVM} = \langle V_{device} \rangle A_{device}$$

$$V_{BVM} = 11.6 \text{ L/min} \quad (11.6 \text{ L/min}) (176.714 \text{ mm}^2) = V (12.56637 \text{ mm}^2)$$

$$A = 176.714 \text{ mm}^2 \quad V = 163.124$$

$$V_{device} = ?$$

$$A = \pi (2 \text{ mm})^2$$

$$= 12.56637 \text{ mm}^2$$

$$\frac{163.1242}{\text{min}} \cdot \frac{1000 \text{ mL}}{\text{L}} \cdot \frac{1 \text{ min}}{60 \text{ sec}} = 2718.74 \text{ mL/sec}$$

It is estimated that our device will be able to deliver up to 2718.74ml/sec

**Conclusions/action items:**

Next, we need to have a testing protocol in place to prove this calculation



# 11/7/2023--Mathematically Calculating Device Size

KATERINA SMEREKA - Nov 07, 2023, 1:47 PM CST

**Title:** Mathematically Calculating Device Size

**Date:** 11/7/2023

**Content by:** Katerina

**Present:** N/A

**Goals:** In order to meet the client required 500ml/3sec air delivery, we need to mathematically calculate the needed diameter

**Content:**

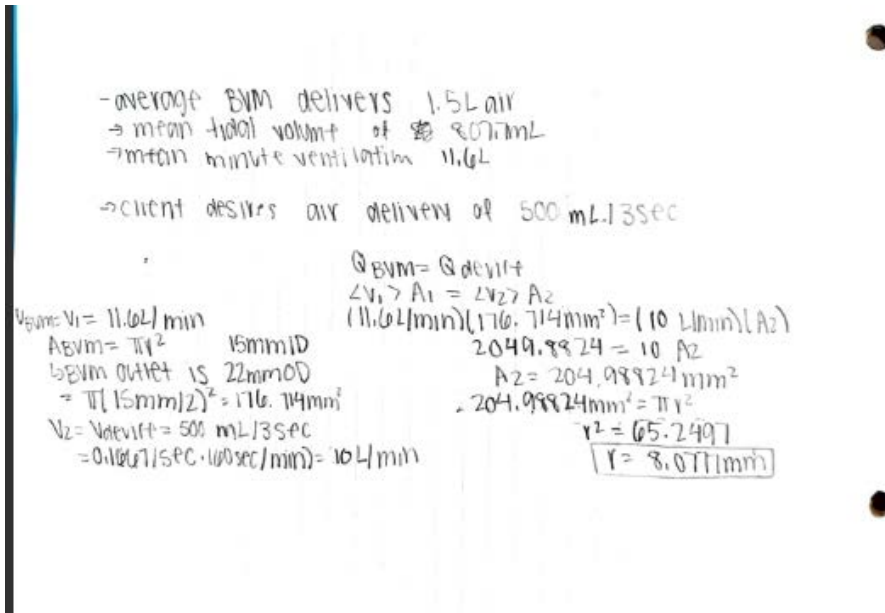

While the quality is not the best, I mathematically calculated using the conservation of flow (?)  $Q_1=Q_2$  and founded the needed cross sectional area for our device to deliver exactly 500ml of air every 3 seconds. This resulted in a radius of 8.077mm for the spout of our device. Should we have a radius less than 8.077mm, then more air is being delivered.

**Conclusions/action items:**

Talk to the team and edit the prototype



# 9/26/2023--The Japanese Soda Handle

---

**Title: The Japanese Soda Handle****Date:** Sept 26, 2023**Content by:** Katerina**Present:** N/A**Goals:** underscore an idea for a design**Content:**

This design is inspired by the mechanism on how to open japanese soda bottles (with the little marble)

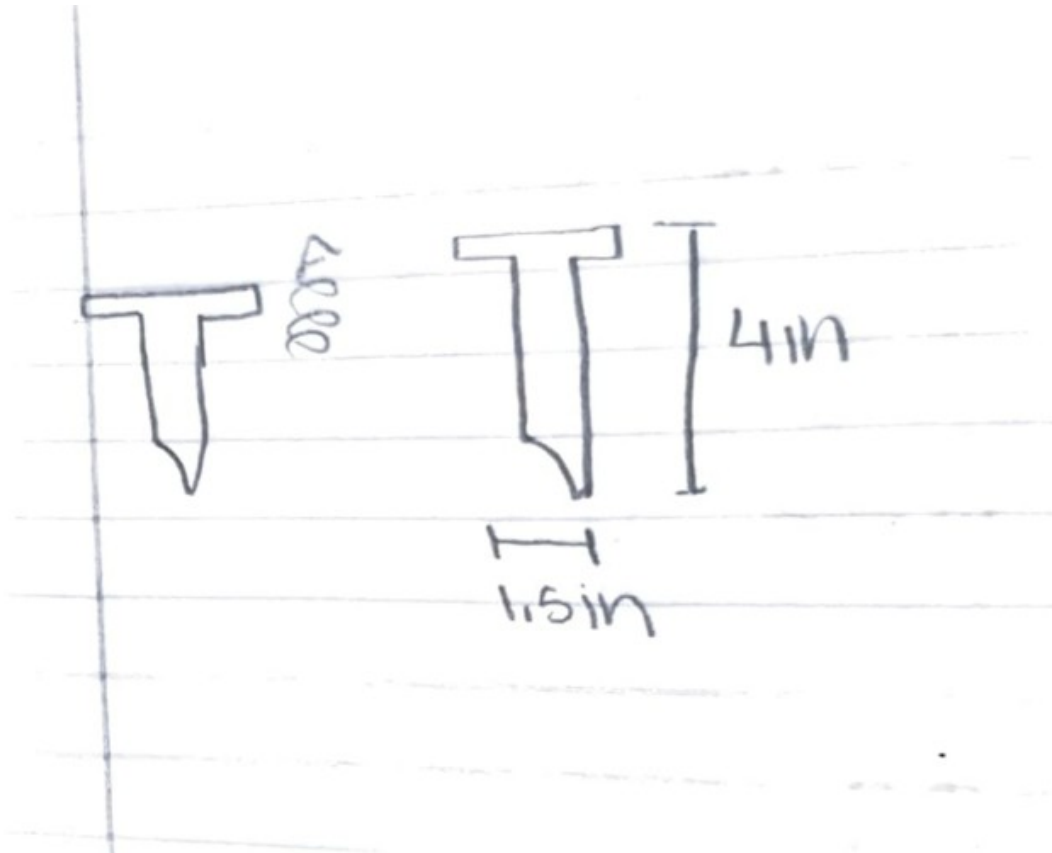

Basically, it is a tube with a super sharp tip. Then there is a ring that screws up and down to certain heights, which corresponds to certain depth that depends on the age, weight and other considerations of patient and their trachea.

How to use:

- 1) Unwrap from package
- 2) Because the tip is super sharp, puncture it initially so it is stable in the skin. Then using the users palm of the hand, push the tube down and it should puncture down and stop at the ring and the depth/height it is set at
- 3) Attach a bag-valve mask in case or wait for EMS to arrive

**Conclusions/action items:**

Need to get this into solidworks and also, need to present this idea to the group





**9/26/2023--The Tampon**

---

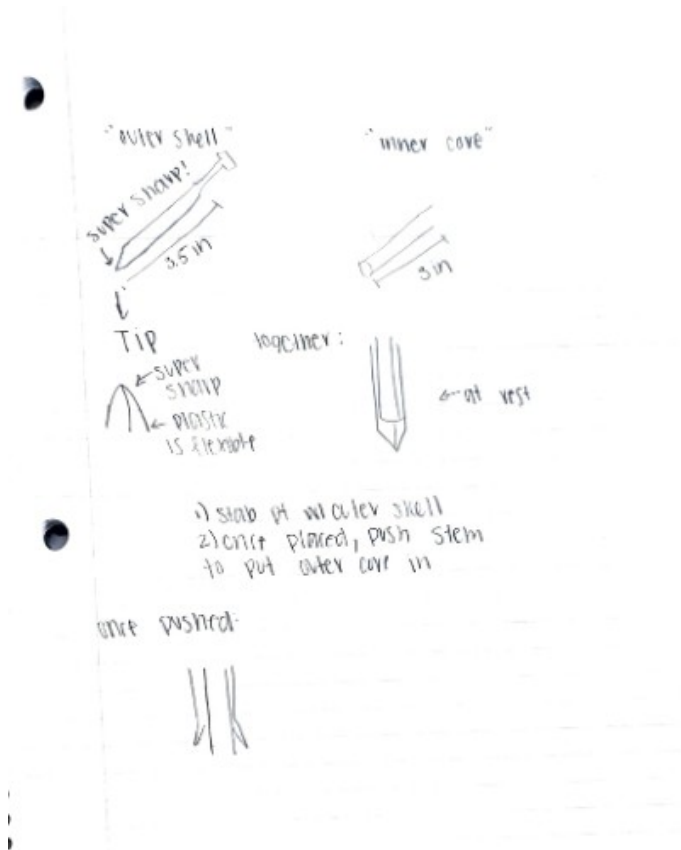
**Title: The Tampon****Date:** Sept 26, 2023**Content by:** Katerina**Present:** N/A**Goals:** underscore an idea for a design**Content:**

This design is inspired by a tampon and how there is a stem that pushes a tampon.

Essentially, there are three components, an outer shell, the inner tube and the stem. The outer shell is made of a biocompatible plastic that at the distal end, it is incredibly sharp. The outer shell is used to puncture the patient. The inner tube is also made of a biocompatible plastic, and it is cylindrical in shape. It's role is to be the airway to be left inserted in the patient. The stem is what pushes the inner tube after the puncture is made.

How to use:

- 1) unwrap packaging
- 2) grip the device and puncture choking patient to create the hole
- 3) use the stem and push the tube into the patient
- 4) pull the outer shell out and let the inner tube rest
- 5) let EMS take over upon arrival or apply bag-valve mask to the end of inner tube

**Conclusions/action items:**

Need to get this into solidworks and also, need to present this idea to the group



**11/9/2023--Overall Apperance,**

---

**Title:** Overall Apperance of the Handle

**Date:** 11/9/2023

**Objective:** Underscore what the handle looks like

**Content:**

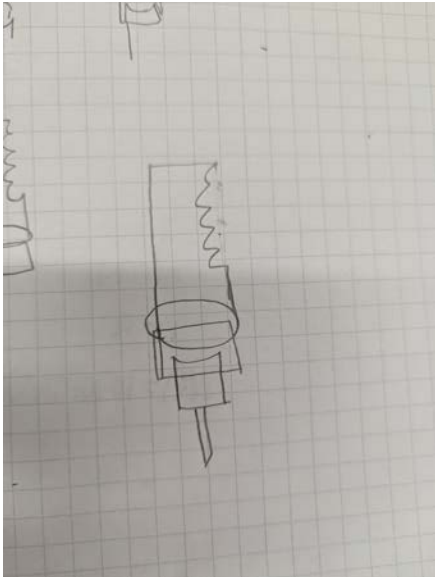

**Dr. Suarez, I am so sorry I am a bad artist. It looks so bad, I know**

**Essentially, there are two components. There is a flat bottom piece that fits with the device and a cylinder that is the handle**

Here it is with dimension:

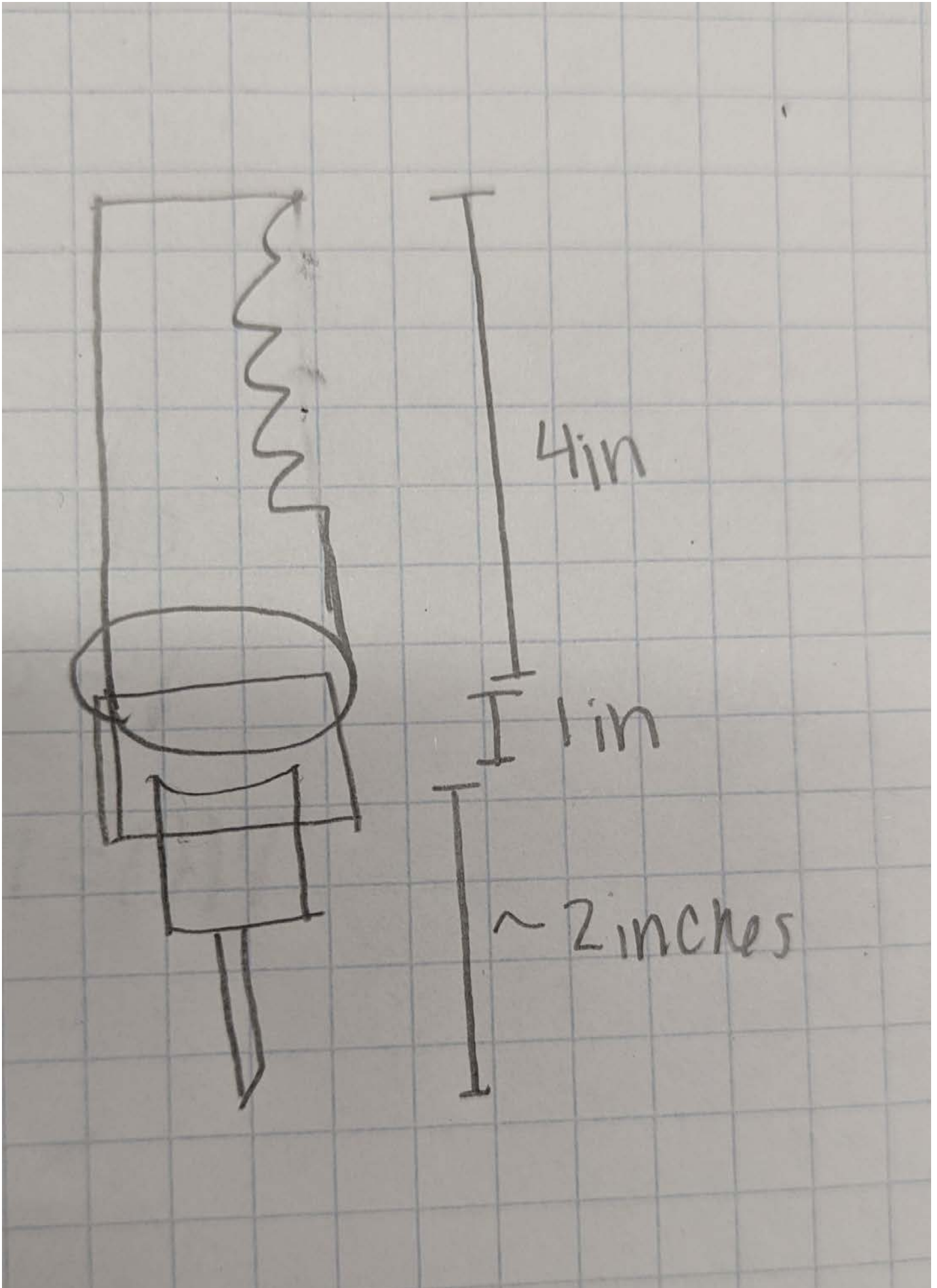

**Conclusion:**

**Need to put this into solidworks to make it more easy to envision**



**11/9/2023--Connection of Handle to Device**

---



**Title:** Connection of Handle to Device

**Date:** 11/9/2023

**Objective:** Underscore how does the handle fit into the device

**Content:**

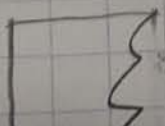
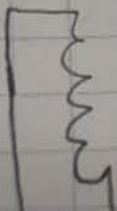
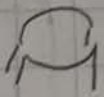
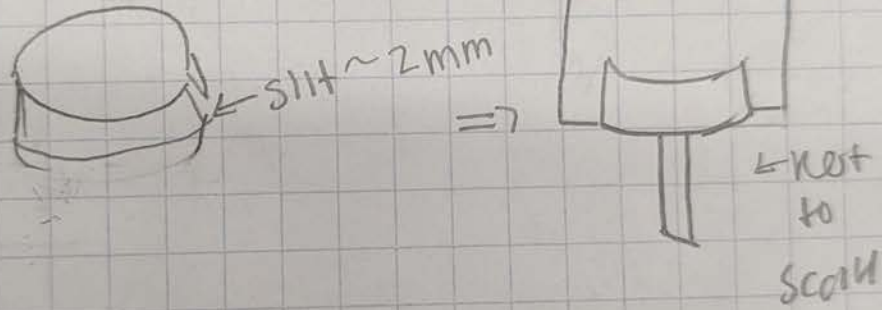

There will be slits in the bvm channel that will connect to the handle where you can slide in to use and then take out to connect bvm

**Conclusion:**

**Put in solidworks!!! (Sorry Dr. Suarez for the bad pictures; not an artist)**



## 12/1/2023--Holder for MTS

KATERINA SMEREKA - Dec 01, 2023, 8:50 AM CST

**Title:** Holder for MTS Machine

**Date:** December 1, 2023

**Content by:** Katerina

**Present:** N/A

**Goals:** get an idea of a connector that could help us secure our device to the mts

**Content:**

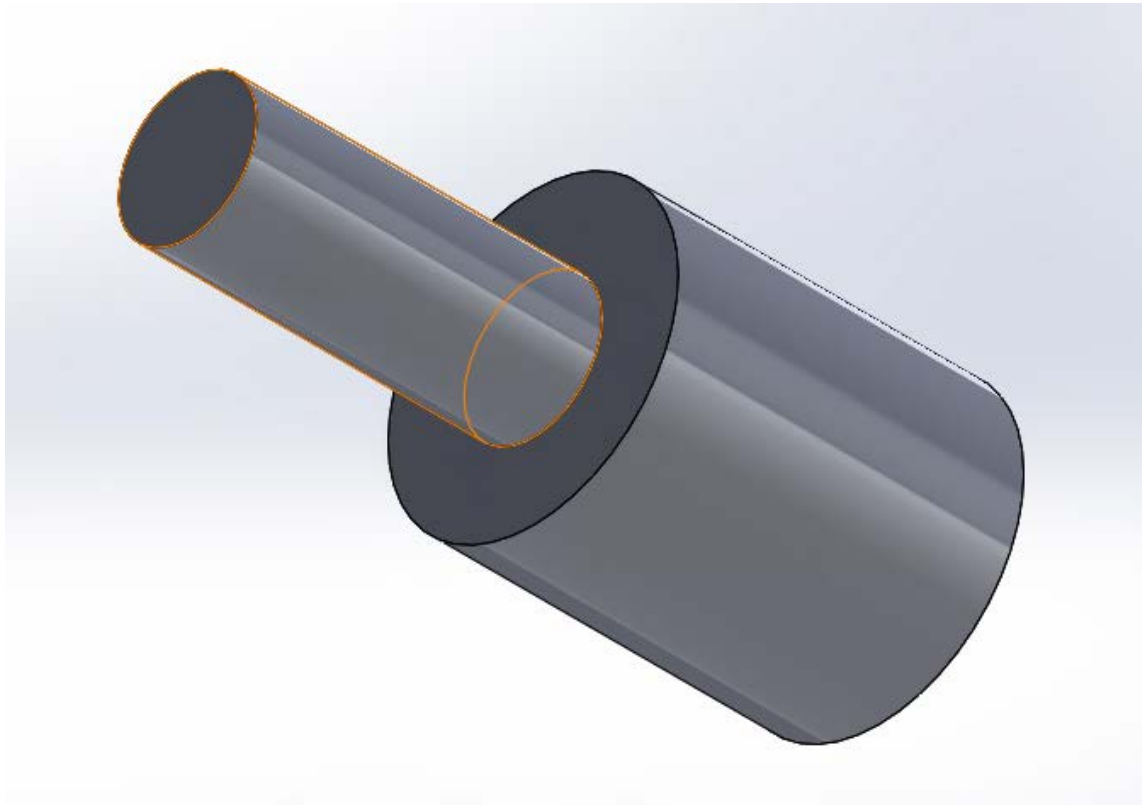

This is the basic idea I have. The outer diameter of the base is 21mm, which should fit our 22mm inner diameter of our device. Then the diameter of the top is 10mm, which is arbitrary, but should be small enough that it can be secured by one of the MTS clamps

**Conclusions/action items:**

**Need to present this to the team to see if they like it**



## 10/24/2023--Testing Protocol, Skin

---

KATERINA SMEREKA - Oct 27, 2023, 7:07 AM CDT

**Title:** Preliminary Testing Protocol

**Date:** October 24, 2023

**Content by:** Katerina

**Present:** N/A

**Goals:** Underscore a first testing protocol to outline how functionality testing will occur

**Content:**

### **Emergency Cricothyroidotomy**

Puncture Test, Skin Only

### **Materials & Equipment:**

- Cricothyroid device, assembled
- Artificial skin
- Ruler
- Permanent Marker

1. Measure on the shank of the device 0.25mm, as this is the average thickness of the skin in the neck area for an average adult (1)
2. Assemble skin and fix edges to a flat surface
3. Attempt to puncture through the skin 0.25mm in depth
4. Let it rest for 4 minutes, observe how the device shifts
5. Remove the device and inspect for damage or how the punctured skin was cut

### **Conclusions/action items:**

**Need a more sound method to clamp down the skin. Need to look at different set ups**



## 10/27/2023--Testing Protocol, Force

---

KATERINA SMEREKA - Oct 27, 2023, 7:12 AM CDT

**Title:** Preliminary Testing Protocol

**Date:** October 27, 2023

**Content by:** Katerina

**Present:** N/A

**Goals:** Underscore a first testing protocol to outline how functionality testing will occur

**Content:**

### **Emergency Cricothyroidotomy**

Force Tet

#### **Materials & Equipment:**

- Cricothyroid device, assembled
- Artificial skin
- Porcine larynx
- Force gauge

1. Assemble the artificial skin and porcine larynx together and fix the larynx to the surface
2. Assemble the cricothyroid device
3. Attach the handle to the force gauge
4. Use the device as directed and get a full puncture through the larynx set up
5. Record the force needed to puncture

-Repeat 4 more times

#### **Conclusions/action items:**

**Do we have access to a force gauge?**



## 10/31/2023--Show and Tell Survey

---

KATERINA SMEREKA - Oct 31, 2023, 5:47 PM CDT

**Title:** Show and Tell Survey

**Date:** October 31, 2023

**Content by:** Katerina

**Present:** N/A

**Goals:** Underscore a preliminary survey to get feedback on intital conceptions of device

**Content:**

1. On a scale of 1 to 5, how approachable is this device? (1 being completely intimidated by this device, 5 being able to slip into pocket and use comfortably) \_\_\_\_\_
2. On a scale of 1 to 5, how prepared do you feel to use this device? (1 being needing extensive/higher level education training, 5 being able to use this device within a minute's notice) \_\_\_\_\_
3. On a scale of 1 to 5, how much force do you imagine you would need to apply to use this device? (1 being immense force, needing to rely on a strong, muscular user, 5 being as much force to push a fluid out of a syringe) \_\_\_\_\_
4. On a scale of 1 to 5, how confident are you that you could identify the cricothyroid membrane using the directions provided (1 being extremely unconfident, 5 being extremely confident) \_\_\_\_\_
5. Using the directions provided, how long do you think it would take you to identify the cricothyroid membrane (please provide in minutes) \_\_\_\_\_

**Conclusions/action items:**

Hopefully this survey will give the team clarity on how approachable our device is and if people feel confident enough to use it in an emergency scenario. Also, this can help us gauge how helpful our directions are and how consise it is, so people can identify the anatomical landmark quickly



**10/27/2023--Testing Protocol, Air Velocity**

---



**Title:** Preliminary Testing Protocol

**Date:** October 27, 2023

**Content by:** Katerina

**Present:** N/A

**Goals:** Underscore a testing protocol to calculate the air flow output of our device

**Content:**

**Emergency Cricothyroidotomy**

Air Velocity Test

**Materials & Equipment:**

- Cricothyroid device, assembled
- Fitted Flow Meter connector
- Air Flow Meter
- Bag Valve Mask
- Timerm

1. Assemble the device and connect the bag-valve-mask to the user end
2. Attach the flow meter connector to the sharp end
3. Attach the flow meter to the apparatus
4. Hold the enitre complex straight up and down (180degree configuration)
5. Deliver BVM rescue breaths according to protocol
6. Record the first breath air velocity and the measurement every 5 seconds for 1 minute
7. Repeat 4 more times

sec	air velocity
0	
5	
10	
15	
20	
25	
30	
35	
40	
45	
50	
55	
60	

sec	air velocity
0	
5	
10	
15	

<b>sec</b>	<b>air velocity</b>
20	
25	
30	
35	
40	
45	
50	
55	
60	

<b>sec</b>	<b>air velocity</b>
0	
5	
10	
15	
20	
25	
30	
35	
40	
45	
50	
55	
60	

<b>sec</b>	<b>air velocity</b>
0	
5	
10	
15	
20	
25	
30	
35	
40	
45	
50	
55	
60	

<b>sec</b>	<b>air velocity</b>
0	

sec	air velocity
5	
10	
15	
20	
25	
30	
35	
40	
45	
50	
55	
60	

**Conclusions/action items:**

**Do we have access to an air flow meter? Next steps would be calculating averages and doing calculations after the testing**



## 2023/9/14 - Initial Research

Mateo Silver - Sep 19, 2023, 10:01 PM CDT

**Title:** Initial Research

**Date:** 9/19/23

**Content by:** Mateo

**Present:** n/a

**Goals:** Learn more about the cricothyroidotomy procedure and when it is performed.

**Content:**

- A cricothyroidotomy is an procedure used when airway access is needed, but inflammation or an object is blocking the airway. An everyday situation where this could occur is choking on food. (1)
- The major organ damage can occur after only 5 minutes with no oxygen (2)
- Airway access through a needle can only be used temporarily. After a cricothyroidotomy, a permanent airway is normally established via a tracheostomy. (1)
- The procedure is usually performed in non-clinical emergency settings, as the small hole made by the cricothyrotomy does not allow for adequate gas exchange. (1)
  - According to our client, at least 500mL of air must be exchanged every 3 seconds.
- There are three major techniques for performing a cricothyroidotomy: needle cricothyroidotomy, the Seldinger technique, and surgical cricothyroidotomy. (1)
  - The first two techniques use a needle to puncture the cricothyroid membrane. The surgical technique makes the incision using a scalpel (1)
- This image shows the proper placement of a cricothyroid device. The cricothyroid space, where the device is placed, lies between the thyroid cartilage and the cricoid cartilage.

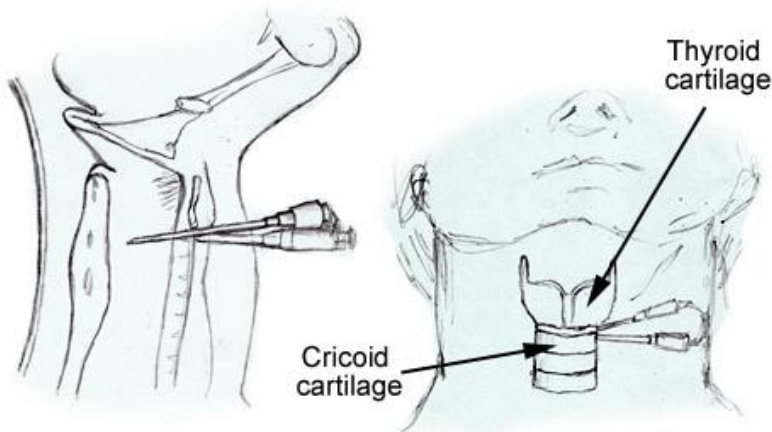

(1) <https://emedicine.medscape.com/article/1830008-overview>

(2) <https://www.merckmanuals.com/professional/critical-care-medicine/respiratory-arrest/overview-of-respiratory-arrest>

**Conclusions/action items:**

Continue researching specific aspects of our device while writing the PDS.



**2023/9/14 - PDS Research**

---

**Title:** PDS Research

**Date:** 9/19/23

**Content by:** Mateo

**Present:** n/a

**Goals:** Learn more about the specifications that our device must be designed to.

**Content:**

**Size:**

Specifications from the client:

- From speaking with client, device should be as small as possible
- The client currently uses a 0.3mL insulin syringe, with the end cut to a point
- A smaller sized device would be more easily added to existing first aid kits
- The device should allow for 500mL of air to pass every 3 seconds

Specifications based on additional research:

- The size of similar products on the market is around that of a 3mL syringe (about 12.5 x 5 x 2.5 cm)
- In the field, a 12-14 gauge needle is often used to create the airway [1]
- Similar products penetrate 15-20 mm into the trachea [2]

**Weight:**

Specifications from the client:

- A device which is lightweight would be easier to include in first aid kits
- The client requests that the weight be as light as possible, for maximum portability

Specifications based on additional research:

- During the design process, the weight distribution should be considered. Proper distribution could allow for better leverage during use
- Similar products on the market utilize a 10mL syringe as part of their design. Using the weight of a 10 mL syringe as a baseline, we could expect our device to weigh about 25 g. [3]

**Materials:**

Specifications from the client:

- The client would like a device that is nonferrous, and can be passed through a metal detector
- The sharp point of the device should not degrade over time
- The device is single use, and does not need to be sterilized between uses.

Specifications based on additional research:

- Any material that comes into contact with the patient should be bio-compatible

## Aesthetics, Appearance, and Finish:

Specifications from the client;

- The client had ideas regarding using specific colors on each part of the device, to make the device instructions more clear
- color, shape are not important to function of the device

Specifications based on additional research:

- Color coding in medical devices is already used as a way to communicate correct usage. For example, in epi-pens, the blue end points upwards (to the sky).

Citations:

[1] J. Fagan, Ed., "1.27: Cricothyroidotomy and Needle Cricothyrotomy," in Open Access Atlas of Otolaryngology, Head and Neck Operative Surgery: Volume 1 - Head and Neck, University of Cape Town Libraries, 2017. doi: 10.15641/0-7992-2534-1.

[2] A. Katayama et al., "Cricothyroidotomy needle length is associated with posterior tracheal wall injury: A randomized crossover simulation study (CONSORT)," *Medicine (Baltimore)*, vol. 99, no. 9, p. e19331, Feb. 2020, doi: 10.1097/MD.00000000000019331.

[3] "Syringe,disp,10ml,w/ndl,21G/BOX-100." <https://supply.unicef.org/s0782112.html> (accessed Sep. 22, 2023).

## Conclusions/action items:

Implement this research when writing the PDS. Get feedback from our advisor before submitting.



## 2023/9/25 - Ideas for Device Testing

---

Mateo Silver - Sep 26, 2023, 9:52 PM CDT

**Title:** Ideas for Device Testing

**Date:** 9/25/23

**Content by:** Mateo

**Present:** n/a

**Goals:** Research how other devices have been tested. See if our team could create a similar model.

**Content:**

Method 1: Testing with ex-vivo larynx and artificial skin [1]

- Researchers studied injury to the posterior tracheal wall during cricothyroidotomy needle insertion
- The aim of the study was to see if shortening the length of the needle from 20 mm to 15 mm would lower the rates of injury
- Residents first trained on a simulator manikin (Cricoid Stick Trainer™), which was covered in tape, 10 times
- During the experiment, an ex-vivo porcine larynx was used
  - The thickness of the cricothyroid membrane was 8 - 12 mm.
- The larynx was covered in an artificial skin, and an endoscope was inserted to record the procedure internally
  - The skin layer was 3 mm thick, and was sourced from BioSKIN (Regina Fashion Supply Co. Ltd., Saitama, Japan)
- The shorter (15 mm) needle only caused injury to the posterior tracheal wall 4% of the time, compared to 33% with the commercial size needle

Method 2: Testing with cadaver [2]

- In testing a new device for cricothyroidotomy, 17 human cadavers were used
- This device utilized a blade to make the initial incision, followed by insertion of a needle to maintain the airway.

Citations:

[1] A. Katayama et al., "Cricothyroidotomy needle length is associated with posterior tracheal wall injury: A randomized crossover simulation study (CONSORT)," *Medicine (Baltimore)*, vol. 99, no. 9, p. e19331, Feb. 2020, doi: 10.1097/MD.00000000000019331.

[2] A. S. P. Tscharlou, J. Klappenberger, S. Klappenberger, and W. Firbas, "A new device for cricothyroidotomy," *Clin. Anat.*, vol. 19, no. 7, pp. 602–604, Oct. 2006, doi: 10.1002/ca.20263.

**Conclusions/action items:**

Ask the client if he has any ideas for how we could test the device. Is the first method above suitable for testing our device?





**2023/10/19 - Competing Design Quicktrach**

---

**Title:** Competing Design Quicktrach

**Date:** 10/19/23

**Content by:** Mateo

**Present:** n/a

**Goals:** Learn more about competing designs on the market.

**Content:**



- The Quicktrach is a product manufactured by VBM to perform an emergency cricothyroidotomy
- The product is designed for use in emergency situations, by trained medical providers
- This design utilizes the catheter-over-needle technique, where a needle is inserted first, then a cannula is placed over the needle, finally the needle is withdrawn
- This technique highlights patient safety and comfort, as only the flexible cannula remains after successful intubation.
- The second generation of this device, the Quicktrach II, also has a small, inflatable pouch which is deployed after the initial placement of the device.
- The inflatable section blocks the upper airway from creating an obstruction that could block the newly formed airway.
- Here, balloon is shown inflated, maintaining the intact lower airway.



- Interestingly, the manufacturers produce two packaging options for the device, a standard sterile pouch and a small form factor tube
- The tube is designed to be portable and easily added to a first-aid/emergency kit
- As our design also aims to be put into first aid kits, we could look further into packaging options that are easy to manufacture while maintaining sterility.



(1) <https://www.vbm-medical.de/en/products/airway-management/cricothyrotomy/quicktrach/>

**Conclusions/action items:**

Continue researching competing designs, draw design inspiration from them.



# 2023/10/19 - Competing Design LifeStat

---

**Title:** Competing Design LifeStat

**Date:** 10/19/23

**Content by:** Mateo

**Present:** n/a

**Goals:** Learn more about competing designs on the market.

**Content:**



General information:

- This device, called the LifeStat, is a portable solution to emergency cricothyroidotomy.
- The cost to purchase the device on their website (2), is \$130
- The device consists of three parts:
  - The trochar is used to create an incision in the patient
  - The cannula is left inserted into the trachea, to allow air to pass
  - The universal adaptor attaches to the cannula, once inserted, and adapts the output to that of a BVM



#### Research paper:

- According to a research paper studying the effectiveness of the device, it has successfully been used 17 times (1)
- 82 percent of uses were in controlled hospital settings, leaving only 18 percent of usage in uncontrolled settings (1)
- Interestingly, this device has also been used in cases of tension pneumothorax, a purpose our client mentioned he might want our device to be used for (1)
- The metal construction allows for sterilization and autoclaving of the device (1)
- The paper also suggests that physicians were more inclined to use this device over a scalpel based technique due to their familiarity with this type of procedure
  - A cricothyrotomy performed using the Seldinger technique is similar to that of placing a vascular line.

#### Safety/legality considerations:

- When looking through the device website, certain legal warnings are seen. These may also be applicable to a device we create.
- Notable FDA warning on their website (2): "THE FDA AUTHORIZES THIS DEVICE FOR USE BY MEDICAL PERSONNEL, ONLY FOR THE PURPOSE OF ESTABLISHING AN EMERGENCY AIRWAY, AND IS NOT TO BE REUSED."
- Another legal warning from their website (3): "Caution: Federal law restricts this device to sale by or on the order of a physician or other practitioner licensed by the laws of the state in which he practices to use or under the use of the device."

(1) <https://doi.org/10.1177/000348940811700101>

(2) <https://www.airstat.org/>

(3) <https://www.airstat.org/pages/instructions.php>

#### Conclusions/action items:

Continue researching competing designs, draw design inspiration from them.



**2023/10/19 - Competing Device LifeStat Patent**

---

**Title:** Competing Design LifeStat Patent

**Date:** 10/19/23

**Content by:** Mateo

**Present:** n/a

**Goals:** Learn more about the LifeStat design by reading its patent

**Content:**

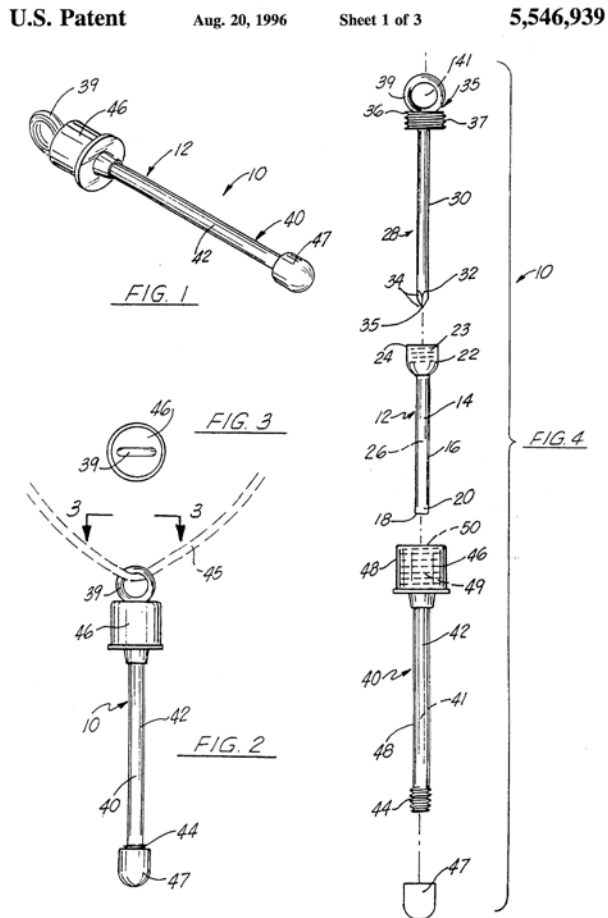

- In researching the LifeStat device mentioned in another competing design entry, I came across the (now expired) patent describing its design
- The patent number is US5546939A, and is linked below (1)
- This design is simple and compact, two points that our design should emphasize
- It is a fully metal construction, which goes against our PDS
- The product consists of three parts, the trochar, cannula, and external adaptor
- First, both the trochar and cannula are inserted, then the trochar (needle end) is retracted, leaving the cannula in place
- This leaves a blunt metal end in the trachea, which may cause injury of the posterior tracheal wall



U.S. Patent

Aug. 20, 1996

Sheet 2 of 3

5,546,939

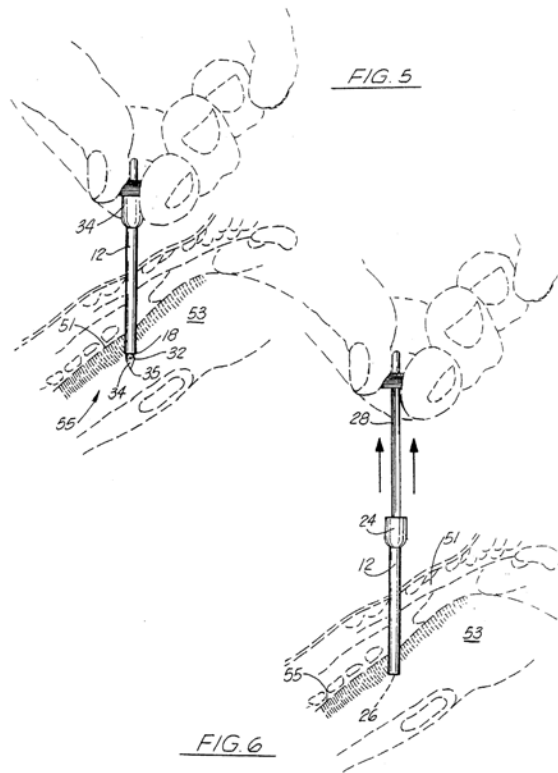

- This device is the only one I have found while doing competing design research that focuses on the portability of the device and utilize a simpler design
- Although the device does not align fully with our design's specifications, this could be a good starting point in creating an effective design solution
- This patent was first filed in 1994, and has since expired in 2014.

(1) <https://patents.google.com/patent/US5546939A/en?q=U.S.+Patent+%235%2c546%2c939+>

**Conclusions/action items:**

Continue researching competing designs, draw design inspiration from them.



## 2023/10/19 - Biocompatible materials

Mateo Silver - Oct 19, 2023, 11:15 PM CDT

**Title:** Biocompatible Materials

**Date:** 10/19/23

**Content by:** Mateo

**Present:** n/a

**Goals:** Research different biocompatible materials we could use.

**Content:**

- When creating a device which will be used in the human body, it is important to choose a material that will not be harmful when it interacts with the body.
- Biocompatible materials are those which do not produce an immune response (1)
- Biocompatibility is defined for a specific use and part of the body. For example a device may be harmless when in contact with the skin, but could cause issues if implanted under the skin.
- The testing of new materials often uses three tests: analytical chemistry, in vitro testing, and finally, animal testing
- The FDA guidelines regulating biocompatibility utilize International Standard ISO 10993-1
- A guidance document produced by the FDA is available here (2)
- Common biomaterials already in use include: Alumina, Bioglass, PVC, PE, PP, PTFE, PMMA, Stainless steel, Titanium
- Aluminum is a biocompatible material which is easily accessible and easy to machine, we may want to consider using it
- This figure shows different interactions that materials can have in a biological system

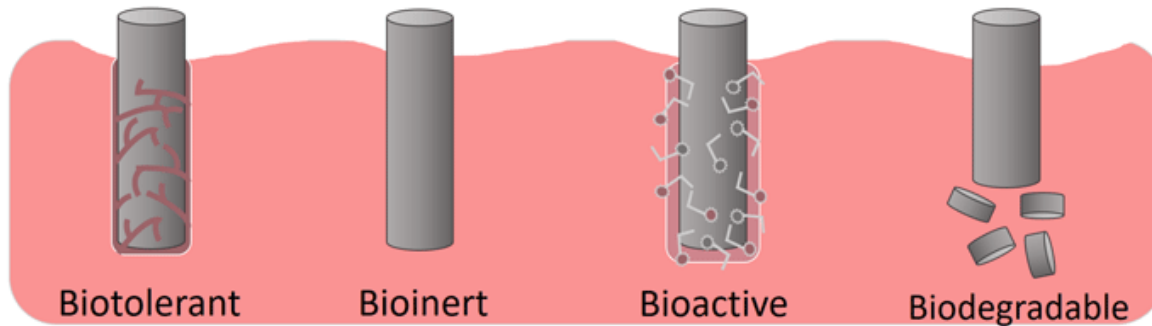

(1) <https://www.cascobaymolding.com/biocompatibility>

(2) <https://www.fda.gov/regulatory-information/search-fda-guidance-documents/use-international-standard-iso-10993-1-biological-evaluation-medical-devices-part-1-evaluation-and>

(3) <https://deringerney.com/what-is-a-biocompatible-material/>

**Conclusions/action items:**

When first deciding on a material, it may be helpful to use one which is known to be safe, as to not need to test it ourselves.



## 2023/10/19 - Makerspace/TEAM Lab Resources

Mateo Silver - Oct 19, 2023, 11:32 PM CDT

**Title:** Makerspace/TEAM Lab Resources

**Date:** 10/19/23

**Content by:** Mateo

**Present:** n/a

**Goals:** Research what materials/tools are available on campus.

**Content:**

- When we begin designing our device, it is important to keep in mind how it will be manufactured
- Here are some of the tools the Makerspace and TEAM lab have available which we could use for manufacturing
  - 3D Printing (resin, extrusion, etc), Laser cutter, CNC Router, Waterjet
- These machines all have advantages and disadvantages, depending on the design we are creating
- It might be useful to utilize the free consultation services the Team Lab provides, to determine the best method to manufacture our product
- Different 3D printing methods are shown in this figure below, courtesy of the Makerspace

### 3D Methods

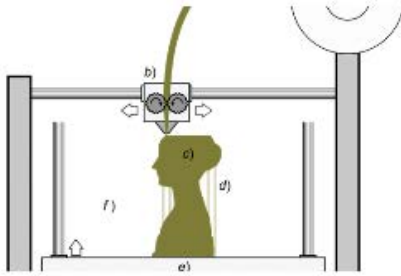

#### FDM/FFF (VIDEO 2)

Fused Deposition Modeling/Fused Filament Fabrication, a continuous filament of thermoplastic through a heated extruder

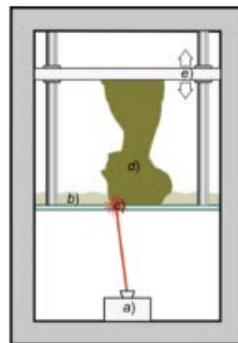

#### SLA (VIDEO 3)

Stereolithography, UV laser-based resin printing. A form of additive manufacturing where a light source, such as a laser or projector, cure a liquid resin into a hardened plastic. The build plate is upside down with a tank of photopolymer resin below and the laser projects through the bottom of the resin tank.

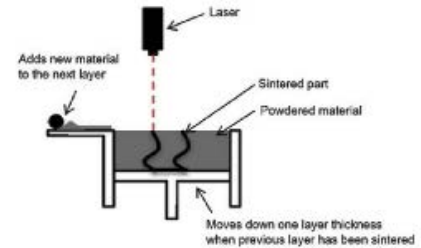

#### SLS

Selective Laser Sintering, uses a laser to fuse polymer powder

- The makerspace also has materials available for purchase, these include: aluminum and plastic stock, dimensional lumber, etc.
  - It may be cheaper and easier to buy stock material online, depending on the dimensions we need.

(1) <https://making.engr.wisc.edu/>

**Conclusions/action items:**

Begin preliminary manufacturing using these resources



**2023/10/25 - Fabrication Research**

---

**Title:** Fabrication Research

**Date:** 10/25/23

**Content by:** Mateo

**Present:** n/a

**Goals:** Determine the tools we should use for each step in fabrication.

**Content:**

- Looking at the tools available on the team lab website (1), we can utilize the lathe to turn the basic shape of our device.
- The TEAM Lab has three Eisen Collet lathes, which can be used for better precision when turning small parts.



- To create the hole near the tip of the device, a drill press can be used
- To sharpen the device to a point, a bench grinder can be used.
- It may be helpful to use stock which is larger than the final part
- The TEAM Lab sells aluminium stock and other metals. They also have a scrap bin where we may be able to find a suitable piece of material.
- Here is a sketch of the steps in the fabrication process:

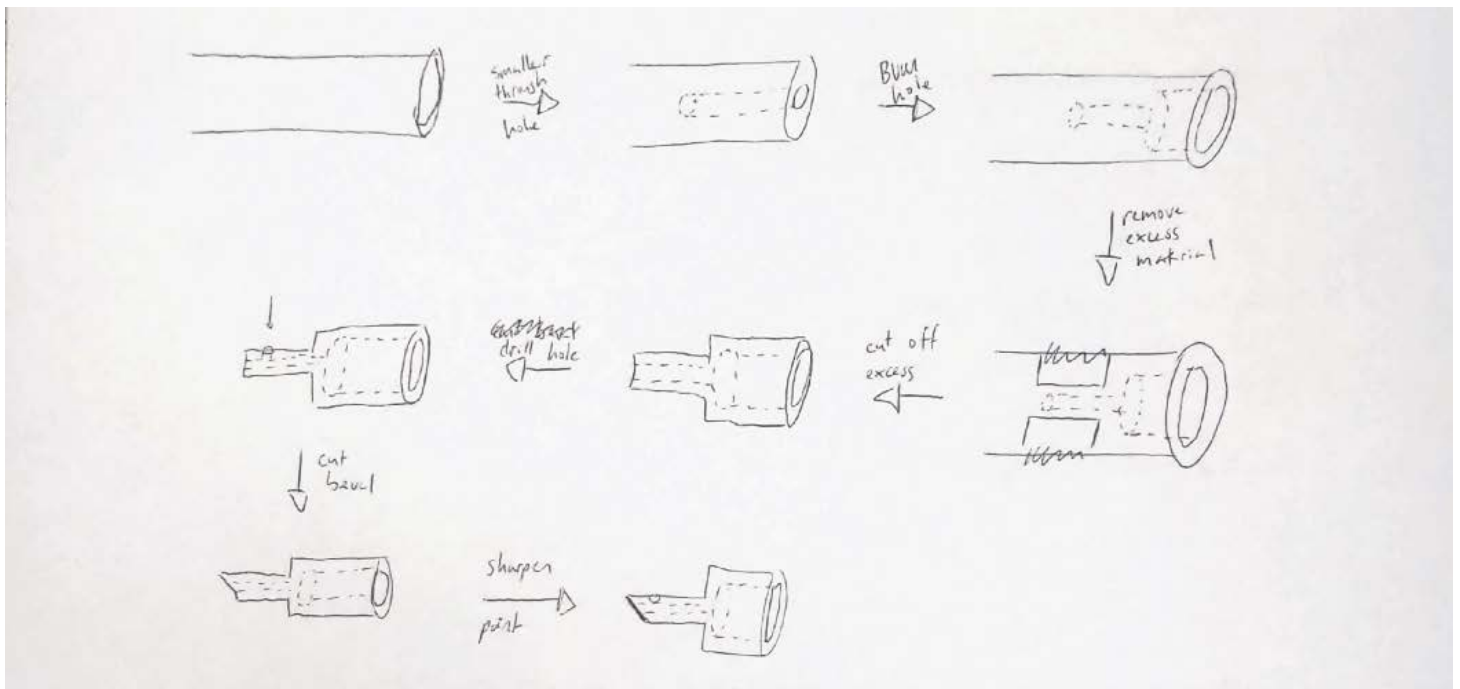

(1) <https://teamlab.engr.wisc.edu/>

**Conclusions/action items:**

Write up fabrication protocol.



## 2023/10/25 - Preliminary Fabrication Protocol

---

**Title:** Preliminary Fabrication Protocol

**Date:** 10/25/23

**Content by:** Mateo

**Present:** n/a

**Goals:** Create a part drawing and write steps for fabrication.

**Content:**

**Materials:**

- 20mm aluminum cylindrical stock

**Tools:**

- Manual Lathe

- Bandsaw

- Drill Press

- Bench Grinder

**Methods:**

Creating 15mm stock (Lathe):

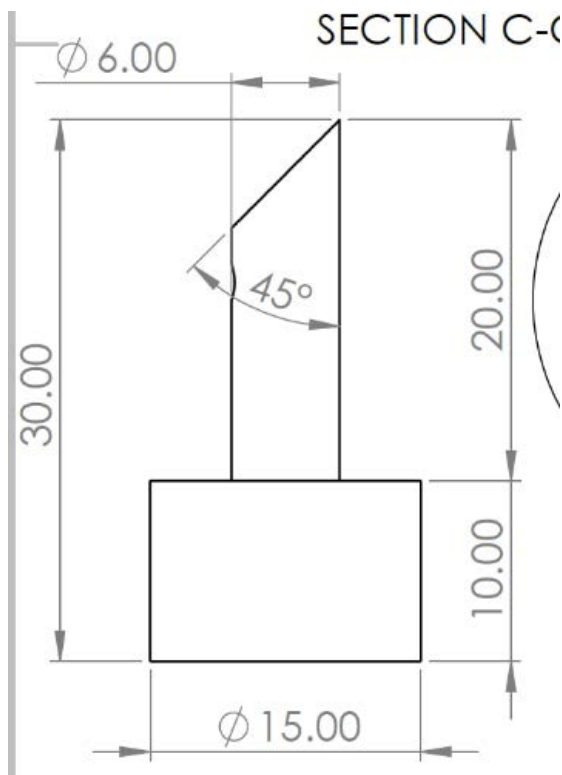

1. Insert aluminum stock into the chuck of the lathe
2. Insert the cutting tool into the tool post
3. Turn the lathe on at 1000 RPM
4. Take a little material off the end of the piece to zero the Z-axis
5. Touch the cutting tip against the circumference of the piece to zero the X-axis. Enter in the measured diameter of the part.
6. Turn the outside of the part, 0.03in at a time, until a diameter of 15mm is reached, 30mm down the length of the stock
7. Ensure the final pass is done slowly and smoothly, to ensure a clean finish

Drilling (Lathe):



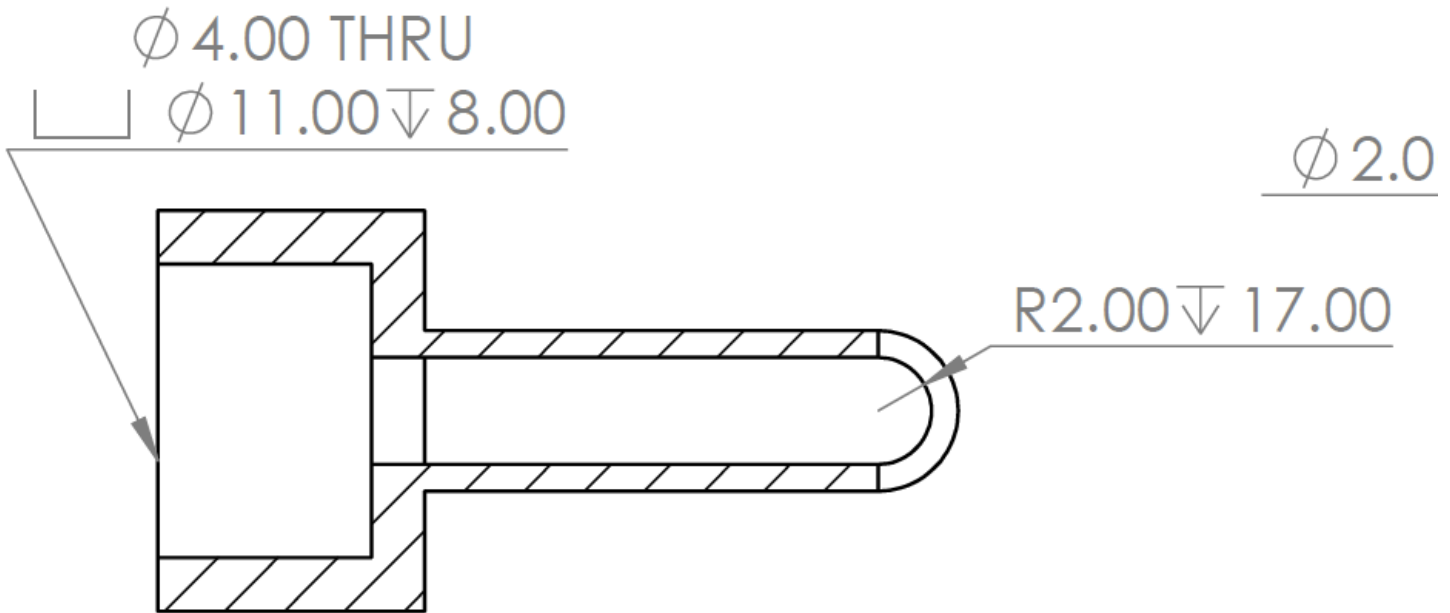

1. Load the keyless chuck into the tail stock
2. Load the spot drill bit into the chuck, tighten the chuck
3. Extend the spot drill until it reaches the part, and zero the depth gauge
4. Turn on the spindle to 1000 RPM
5. Drill the spot drill to a depth of 0.050"
6. Shut off the spindle, replace the spot drill with a 4mm drill bit.
7. Extend the drill bit until it reaches the part, and zero the depth gauge
8. Turn on the spindle to 1000 RPM
9. Peck drill, until the depth reaches 30mm
10. Repeat steps 6-9, with an 11mm bit, to a depth of 8mm

Creating smaller diameter section (Lathe):

1. Insert the cutting tool into the tool post
2. Turn the lathe on at 1000 RPM
3. Move the cutting tool to a depth of 10mm
4. Gradually remove material from 10mm to 30mm depth
5. Remove 0.03in of material at a time, until a diameter of 6mm is reached
6. Ensure the final pass is done slowly and smoothly, to ensure a clean finish
7. Remove the piece from the chuck. Use a bandsaw to cut off the remaining stock material.

Drilling Vent Hole (Drill Press):

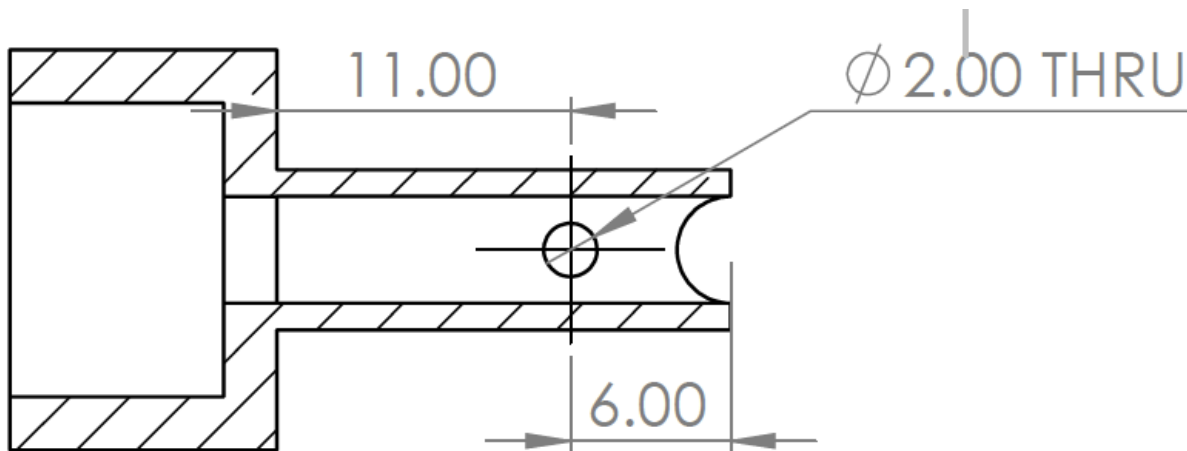

SECTION A-A

1. Place the part securely into a vice, use RPM chart to determine correct speed for drill press
2. Measuring 9mm from the narrow end of the part, drill a 2mm hole to a depth of 3mm (through only one side)

Cut Bevel (Bandsaw):

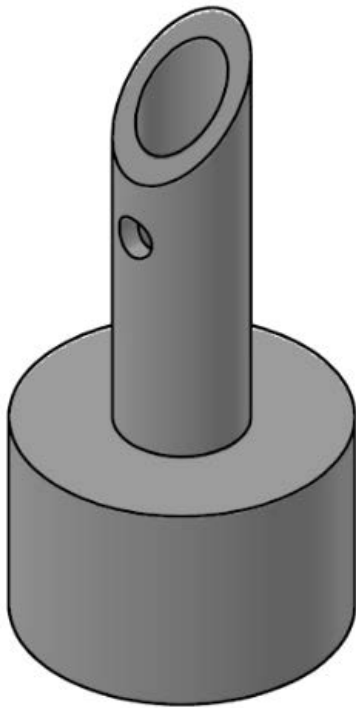

1. Set the miter gauge of the bandsaw to 45 degrees
2. Create a bevel, starting at the end of the part, on the side opposite the vent hole that was just drilled
3. Make the cut, the short end (the side with the vent hole) should now measure 14mm

Sharpen Point (Bench Grinder):

1. Using the bench grinder, sharpen the outer edge of the cutting tip

Conclusions/action items:

Begin preliminary manufacturing by following this protocol.

Mateo Silver - Oct 25, 2023, 4:42 PM CDT

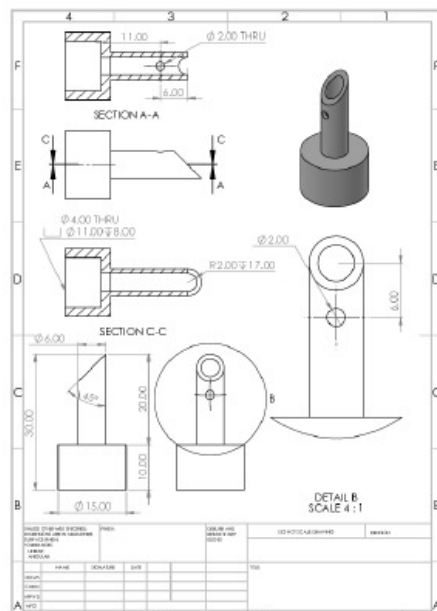

[Download](#)

HolePuncher.pdf (68.3 kB)



## 2023/11/22 - Fabrication Process

---

**Title:** Fabrication Process

**Date:** 11/22/23

**Content by:** Mateo

**Present:** n/a

**Goals:** highlight steps of the fabrication process

**Content:**

Here are a few photos of the fabrication process, which was done in the TEAM Lab.

The first step was done on the lathe. Starting with 1" aluminum stock, the main outer and inner diameters were turned, in 0.003" increments.



Next, the hole in the thinner end of the device was created. The hole was spot drilled, then tap drilled until reaching the depth of the main body of the part.



After that, the part was cut-off using the drop saw. The piece was then placed back into the lathe and the other end was drilled out. First with a normal bit, then a flat end mill.



Here is the piece following lathing.



To create the pointed end of the device, the piece was placed in a  $63/64$ " collet. It was inserted into the mill vice at a 45 degree angle using angle blocks. The end was milled until the desired angle was obtained.



Finally, the piece was turned upside down and the small hole was drilled on the mill.

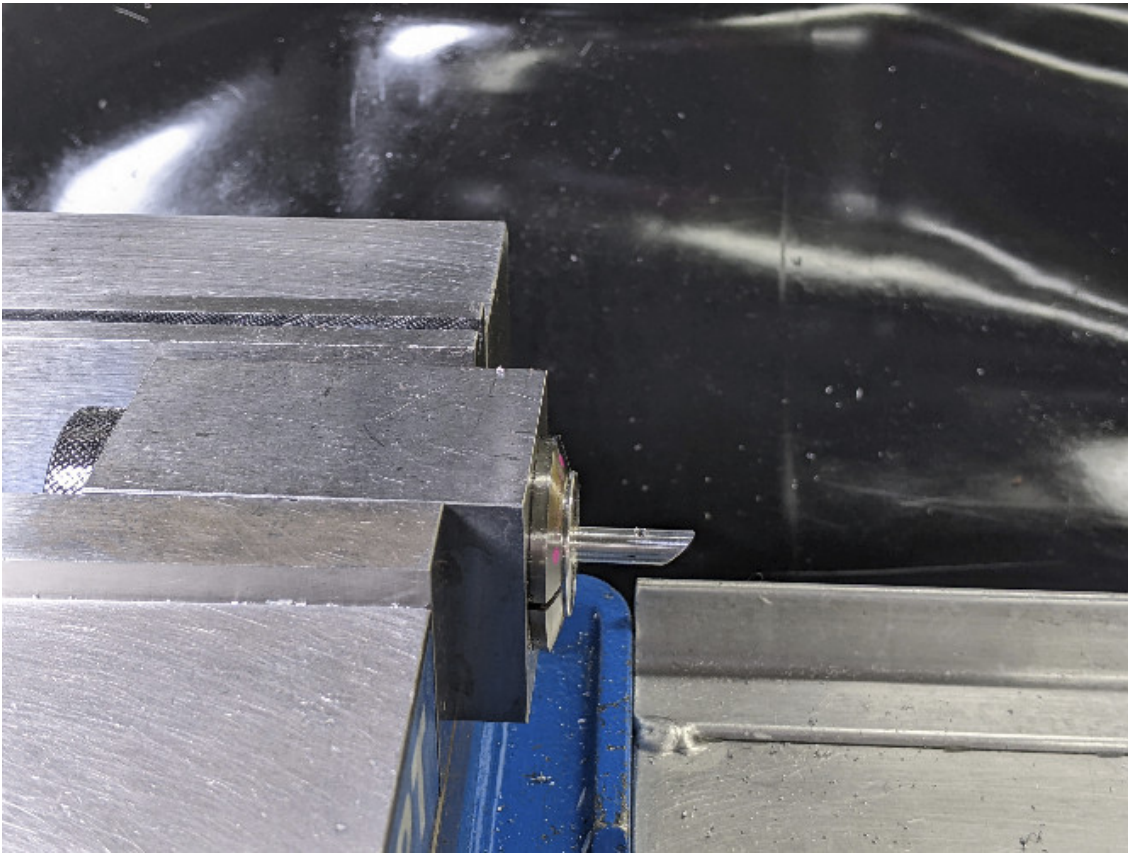

Here is a photo of the finished piece.

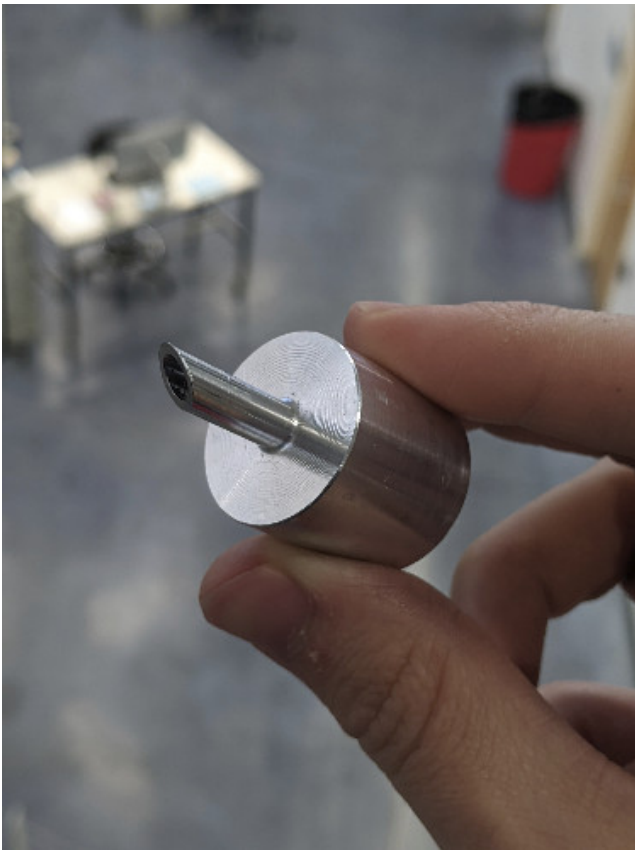

**Conclusions/action items:**

Include these photos in the final fabrication protocol.





# 2023/12/10 - Final Fabrication Protocol

---

**Title:** Final Fabrication Protocol

**Date:** 12/10/23

**Content by:** Mateo

**Present:** n/a

**Goals:** Document entire fabrication process in detail.

**Content:**

Materials

- 1" aluminum rod stock, at least 3" long

Tools:

- Manual lathe
- Drop saw
- Vertical milling machine
- Bench grinder

## Methods:

### A. Machining on Lathe

1. **Setting up the lathe:** Measure the diameter of the aluminum stock. Place the aluminum stock in the chuck with approximately 2 inches hanging out. Insert the cutting tool into the tool post, and set the machine into high gear. Make sure to rotate the chuck while changing gears to allow them to mesh. Pull the spindle lever upwards to start the lathe. Adjust the RPM of the machine to approximately 1000 RPM. If machining the part out of a different material, consult the RPM tool to determine the correct RPM. The chuck should be spinning counterclockwise.
2. **Zeroing the Z-axis:** Do this by moving the tip of the cutting tool towards the face of the part. Once light contact is made, use the x-axis handwheel to move the tool off the face of the part. Stop the machine and zero the z-axis on the DRO. Turn the z-axis handwheel until the DRO reads -0.015". Zero the DRO again, and face off the part. Make sure to only move the x-axis handwheel when facing off.
3. **Setting the X-axis diameter:** Move the cutting tool along the z-axis until it is along the edge of the part. Slowly turn the x-axis handwheel clockwise until light contact is made against the diameter of the part. Turn the z-axis handwheel clockwise to move off of the part. Make sure not to move the x-axis handwheel at this time. Turn the machine off, and set the x-axis measurement on the DRO to the measured diameter of the stock.
4. **Cutting the major diameter:** Set the x-axis on the DRO to the outer diameter of the part, 0.990". Moving only the z-handwheel, take the cutting tool down the length of the part, stopping about 0.2" before the spindle. Stop the spindle and measure the diameter of the part. Update the DRO diameter reading if the

numbers do not match. Make a final pass to create the actual outer diameter of 0.9843". Move slowly to ensure a good surface finish.



6. **Spot drilling the minor diameter channel:** Remove the cutting tool from the tool post. Place the keyless chuck into the tailstock. Secure the spot drill into the chuck. Move the tailstock towards the part, lock it in place. Touch the spot drill to the face of the part and zero the digital readout. Retract the chuck away from the material and turn the spindle on at approximately 800 RPM. Spot drill until a readout of -0.04" is reached.
7. **Drilling the minor diameter channel:** Next, the 0.1572" diameter channel will be drilled out. Use a 5/32" bit, or a more accurate drill bit if available. Turn the spindle on at 1000 RPM. Peck drill until a depth of approximately 1.000". Make sure to completely remove the bit out of the hole while drilling to remove debris.



8. **Cutting off excess stock:** Using the drop saw, cut the excess stock off of the part. For aluminum, the drop saw should run at 200 RPM. Leave an extra 0.1" or so the part can be machined to it's final length. For example, the final part length is 1.6929", so make the cut at 1.8"
9. **Cutting the part to its final length:** Measure the length of the major diameter section. Place the part back in the lathe chuck, with the major diameter facing outwards. Set the cutting tool into the tool post, and face off the part. Set the z-axis DRO to the measured length. Taking 0.03" cuts, cut the length of the part down to 0.92". On the final pass, take a cut at 0.9055", moving the x-handwheel slowly to ensure a good surface finish.

- 10. Spot drilling the major diameter channel:** Remove the cutting tool and place the spot drill into the keyless chuck. As before, zero the spot drill against the face of the material. At 800 RPM, spot drill until a depth of  $-0.04"$ .
- 11. Drilling the major diameter channel:** Finally, the  $0.8661"$  diameter channel will be drilled. Use a  $55/64"$  bit, or a more accurate drill bit if available. Turn the spindle on at 275 RPM. Peck drill until a depth of approximately  $0.7874"$ . Make sure to completely remove the bit out of the hole while drilling to remove debris. Next, replace the bit with an flat end mill of the same diameter. At as slow an RPM as possible ( $\sim 237$  RPM), drill down to the same length as before. This creates the flat bottom of the channel



- 12. Part Deburring:** Move the carriage away from the chuck. Then, at 300 RPM, use a file to knock off the sharp edges. File down all sharp edges, on both sides of the part. Use swivel head deburring tools to clean up the inside of the minor diameter channel.

## B. Machining on Mill

- 1. Setting up the Mill:** Place the piece in a  $63/64"$  collet block to secure it. Using a  $45^\circ$  angle block, clamp the piece down at an angle. Place a  $1/2"$  2-flute aluminum endmill in the collet, and load the collet into the spindle.
- 2. Zeroing the z-axis:** Align the tip of the part with the drill bit. Turn the mill on at 1000 RPM. Raise the z-axis upwards until contact is made with the part. Zero the z-axis on the DRO.
- 3. Creating angled edge:** Removing ten thousandths of material in each pass ( $0.01"$ ), begin taking material off the end of the tip. Make sure to use cutting oil for lubrication and cooling. One may need to move the part in the x and y axes to ensure the entire tip is machined. Move more slowly as you begin taking off more material with each pass. Stop when a z depth of  $-0.167"$  is reached.



4. **Removing the endmill:** Remove the part from the clamp and turn it over so that the longer end of the needle is facing upwards. Reclamp the piece and lower the table. Ensure that the quill is all the way up and locked, then remove the collet and endmill. Load the keyless chuck into the spindle and place the edge finder into the chuck.
5. **Zeroing the y-axis:** Maneuver the table and quill until the edge finder is along the side of the shaft. Turn the mill on at 800 RPM. Slowly move the edge finder until it makes contact with the side of the shaft closest to you. Keep going until the edge finder begins to break the other way. Raise the quill and zero the y-axis on the DRO. Compensate for the radius of the edge-finder by setting the y-readout to 0.250", then zero again. Next, use the edge finder to locate the edge of the other side of the shaft. Make sure to compensate for the radius of the edge finder. Note the diameter of the shaft you just found. Zero the y-axis again, so that it is zero at the edge of the shaft. Move the y-axis the distance of the radius of the shaft and zero it one last time.
6. **Zeroing the x-axis:** Place the edge finder near the tip of the shaft, where the y-axis DRO reads 0.0000. Gradually turn the x-handwheel until the edge finder makes contact, then breaks the other way. Zero the x-axis on the DRO. Remove the edge finder from the keyless chuck.
7. **Spot drilling the additional hole:** Place the spot drill into the keyless chuck. Move the part until the DRO reads 0 in the y-axis and -0.345 in the x-axis. Bring the quill down until it touches the part, then zero the quill readout. Turn on the spindle at a speed of 1000 RPM. Tap the spot drill until it just makes contact. Make sure not to drill too far as to make a spot drill hole which is larger than the drilled hole. Remove the spot drill from the keyless chuck.
8. **Drilling the additional hole:** To create the additional hole, which has a 0.0787" diameter, use a 5/64" bit, or a more accurate drill bit if available. Lower the quill until the bit touches the part and zero the quill readout. At 1500 RPM, drill through only one side of the shaft, approximately a depth of 0.03935".

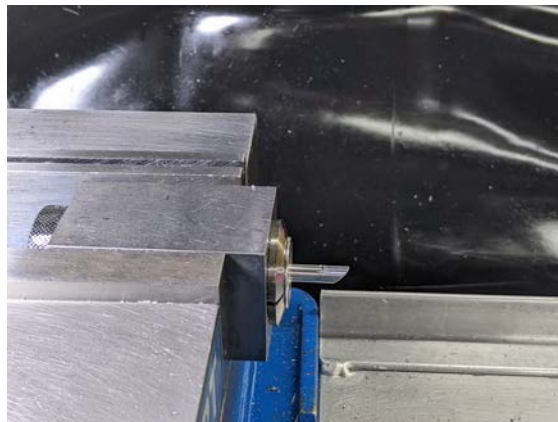

9. **Part Deburring:** Use a file to deburr the angled edge created. Use a swivel head deburring tool to reach the inner portion of the angled edge. Finally, use a countersink deburring tool to clean up the additional hole.

#### C. Sharpening on Bench Grinder

1. **Creating a Beveled Edge:** Using a bench grinder or other sharpening tool, grind each side of the tip of the device to a 45° angle. This creates a sharp point similar to that of a hypodermic needle.

#### **Conclusions/action items:**

Include in the appendix of the final report.



## 2023/11/9 - Device Instructions v1

Mateo Silver - Nov 09, 2023, 10:22 PM CST

**Title:** Device Instructions V1

**Date:** 11/9/2023

**Content by:** Mateo

**Present:** n/a

**Goals:** Begin working on new interactive device instructions, based on feedback.

**Content:**

- When presenting our design at show and tell, we received valuable feedback from our peers regarding the instructions for using the device
- One suggestion was to use a paper "template", which the user places over the patient. This would help them correctly position the device, as well as reduce anxiety by obscuring the patient
- Attached to this entry is my first attempt at creating device instructions, they will be scaled to match a standard patient's anatomy and tested by our team.

**Conclusions/action items:**

Present instruction idea to team, iterate on their ideas.

Mateo Silver - Nov 09, 2023, 10:22 PM CST

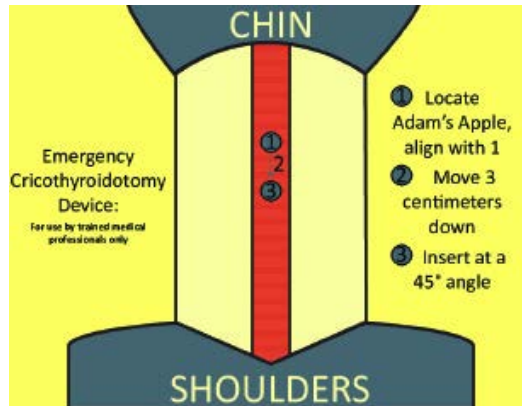

[Download](#)

**Emergency\_Cricothyroidotomy\_Device\_Instructions.pdf (593 kB)**



## 2023/9/26 - Individual Design #1

Mateo Silver - Sep 26, 2023, 10:15 PM CDT

**Title:** Individual Design #1

**Date:** 9/26/23

**Content by:** Mateo

**Present:** n/a

**Goals:** Present my first design idea.

**Content:**

Below is my first design. It is bulkier than the other designs I came up with, but the added grip serves two purposes. It allows the user more control in positioning the device, as well as serving as a depth stop to ensure proper insertion. The outer end of the device will be designed as to attach to a bag valve mask.

The length of the needle is 15-20 mm, similar to other designs on the market. The gauge of the needle will have an inner diameter around 4 mm, to allow adequate ventilation.

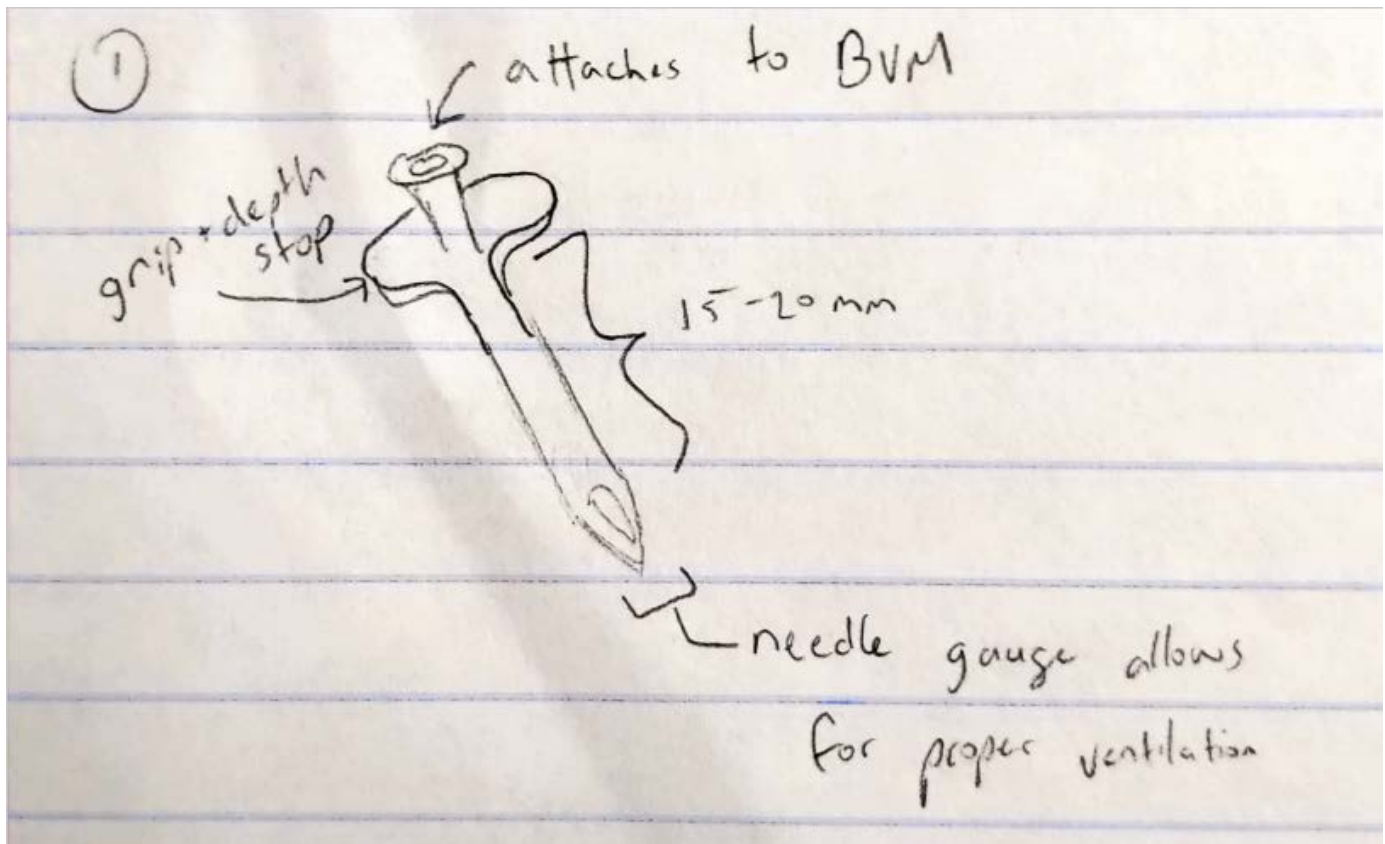

**Conclusions/action items:**

Meet with team to discuss their design ideas





## 2023/9/26 - Individual Design #2

Mateo Silver - Sep 26, 2023, 10:23 PM CDT

**Title:** Individual Design #2

**Date:** 9/26/23

**Content by:** Mateo

**Present:** n/a

**Goals:** Present my second design idea.

**Content:**

Below is my second design. It is a smaller and more compact version of the first design. Instead of a large grip, the top has been reduced to just a flange. The needle and bag valve mask compatibility are the same as the other designs.

This lightweight design focuses more on the portability aspect of the PDS, as opposed to user experience. This tradeoff may be acceptable if the device will be targeted towards experienced medical professionals, as opposed to the general public.

The length of the needle is 15-20 mm, similar to other designs on the market. The gauge of the needle will have an inner diameter around 4 mm, to allow adequate ventilation.

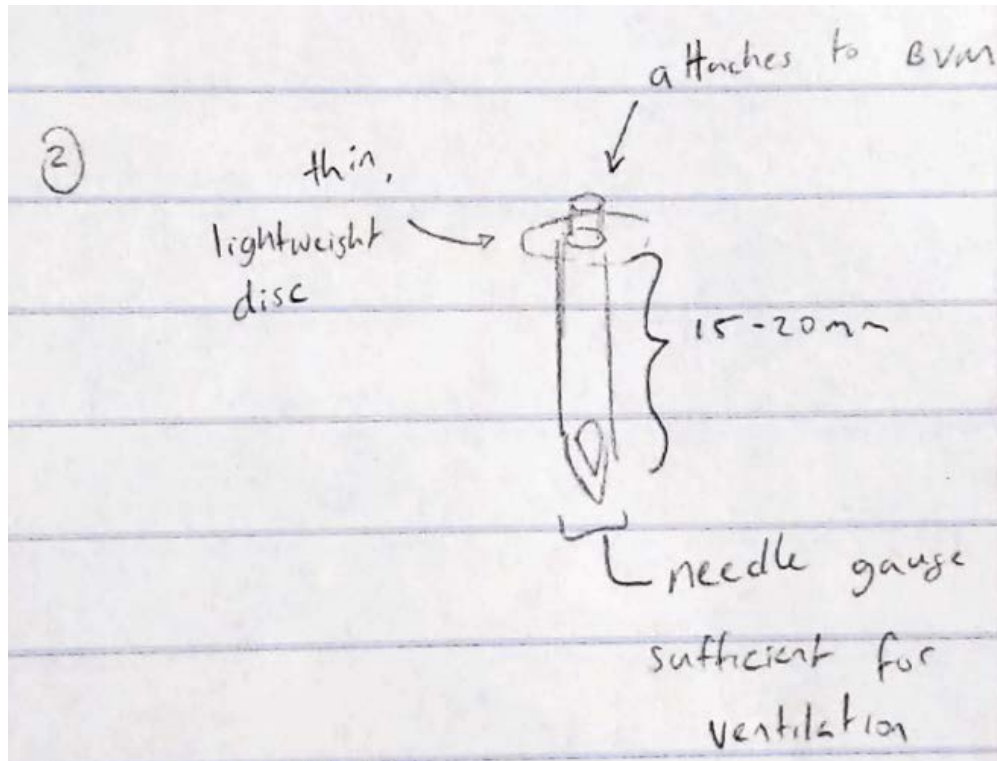

**Conclusions/action items:**

Meet with team to discuss their design ideas



## 2023/9/26 - Individual Design #3

Mateo Silver - Sep 26, 2023, 10:27 PM CDT

**Title:** Individual Design #1

**Date:** 9/26/23

**Content by:** Mateo

**Present:** n/a

**Goals:** Present my first design idea.

**Content:**

Below is my third design. As opposed to the first two designs I proposed, this one is curved to aid in placement. When a cricothyroidotomy device is placed, it is first inserted perpendicular to the skin, then tilted caudally to 45 degrees. A bent device could assist in the usage of the device. It could also potentially be marked to visually demonstrate when the user should tilt the device. Once the device is placed correctly, the end would be flush against the skin.

The needle and bag valve mask ends of the device are similar to the previous two designs. The length of the needle is 15-20 mm, similar to other designs on the market. The gauge of the needle will have an inner diameter around 4 mm, to allow adequate ventilation.

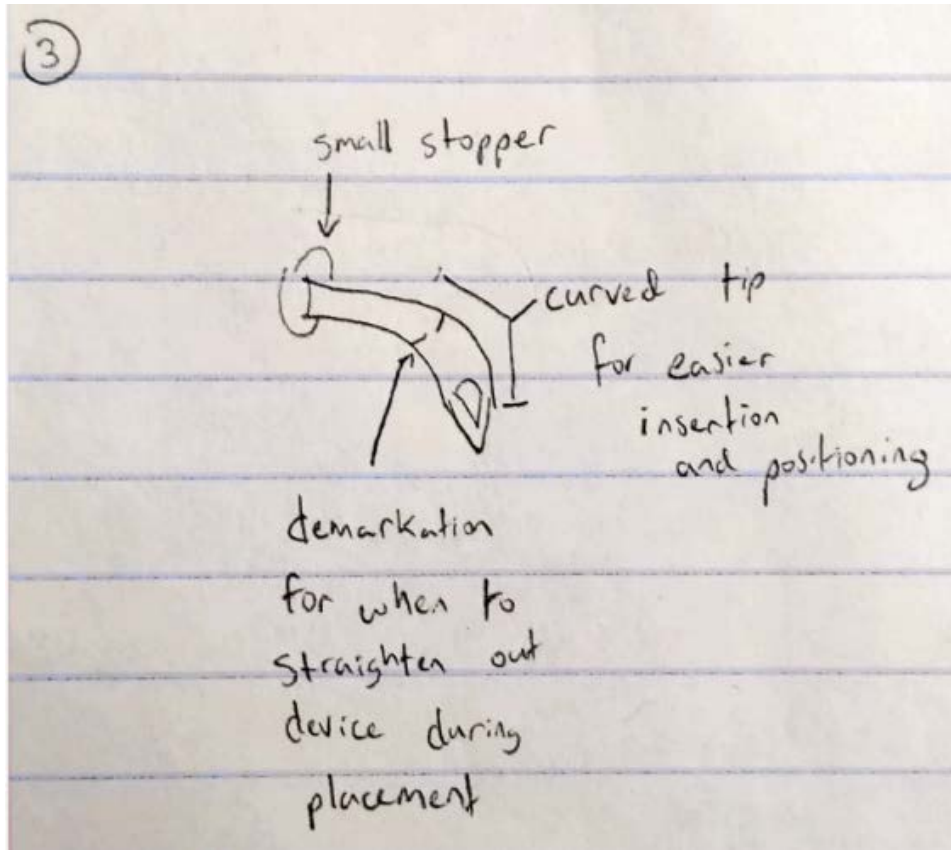

**Conclusions/action items:**

Meet with team to discuss their design ideas



## 2023/10/19 - Biosafety and Chemical Training

Mateo Silver - Oct 19, 2023, 9:19 PM CDT

**Title:** Biosafety and Chemical Training

**Date:** 2023/10/19

**Content by:** Mateo Silver

**Present:** n/a

**Goals:** Show proof of Biosafety and Chemical Training

**Content:**

Proof of training below:



This certifies that Mateo Silver has completed training for the following course(s):

Course	Assignment	Completion	Expiration
2020-21 HIPAA Privacy & Security Training	HIPAA Quiz	5/20/2021	
Biosafety 105: Biosafety Cabinet Use	Biosafety 105: Biosafety Cabinet Use Quiz	1/31/2022	
Biosafety 107: Centrifuge Safety	Biosafety 107: Centrifuge Safety Verification Quiz	1/31/2022	
Biosafety Required Training	Biosafety Required Training Quiz 2022	1/31/2022	
Chemical Safety: Personal Protective Equipment	PPE Final Quiz	1/31/2022	
Chemical Safety: The OSHA Lab Standard	Final Quiz	1/31/2022	

**Conclusions/action items:**

Biosafety training may be useful when we begin testing on animal models.



## 2023/10/19 - Green Permit Training

**Title:** Green Permit Training

**Date:** 2023/10/19

**Content by:** Mateo Silver

**Present:** n/a

**Goals:** Show Proof of Green Permit Training

**Content:**

Proof of training below:





Welcome, Mateo Silver  
You are logged in to the  
EMU Reservation System

TEAM Lab
Reserve a Machine
My Reservations
My Status

Materials Fee is paid through 2022-06-30. [See Receipt](#)

---

You may apply for the following upgrades:

Name
Welding 1
CNC Mill 1
Woodworking 1
CNC Lathe Haas 1

---

You have the following permits and upgrades:

Name	Date
Green Permit	03/03/2022
Lab Orientation	09/27/2020
Red Permit	02/12/2022
Laser 1	10/06/2020

**Conclusions/action items:**

The green permit will allow me to use the mill and lathe in the team lab to manufacture our design.



## 2023/11/10 - Tong Lecture Notes

---

Mateo Silver - Nov 10, 2023, 12:28 PM CST

**Title:** Tong Lecture Notes

**Date:** 11/10/2023

**Content by:** Mateo

**Present:** n/a

**Goals:** Learn from and reflect on the Tong Lecture

**Content:**

- Speaking: Travelle (Franklin-Ford) Ellis, MD, PhD
  - Undergrad at Pitt
  - Her journey through finding a field that interested her, biomedical engineering
  - The soft skills that resonated with her: leadership, teamwork, problem solving
  - Began MD-PhD at UW's MSTP program
  - mentoring and helping the community, through PEOPLE program
  - didn't match after MD, utilized network to find a next step
  - Health Equity Director at Exact Sciences
    - still tied to her original goal of utilizing technology to help people
  - Dr. Ellis' advice for all stages of career
- 1) Find your people
    - the people in your corner, throughout your journey
    - people like you and unlike you
    - building your network
    - forging a path for the people who come next
  - 2) Do things that scare you
    - push yourself out of your comfort zone
    - advocating for your people, lean on support from your network
  - 3) Laugh until you cry, cry until you laugh
    - someone is counting on you

**Conclusions/action items:**

This year's Tong Lecture: One Engineer's Journey: Where Preparation Meets Opportunity



## 2023/12/13 - Outreach Proposal Research

---

Mateo Silver - Dec 13, 2023, 2:54 PM CST

**Title:** Outreach Proposal Research

**Date:** 12/13/2023

**Content by:** Mateo

**Present:** n/a

**Goals:** Complete outreach activity proposal, investigate the applications of hydrogels in medicine.

**Content:**

Our outreach project involves creating hydrogels and investigating their potential applications. To better facilitate the activity, I conducted some basic research on the definitions and applications of hydrogels. Our audience is elementary school students, so the definitions must be comprehensible to this audience.

Basic definitions:

- Hydrogel: A tangled web that can absorb water or other liquids.
- Biomedical engineering: Applying engineering skills to create tools that solve medical problems. The tools can be machines such as an X-ray machine, or devices like crutches or a cast.
- Therapeutic: Used to heal a disease or injury.
- Crosslinking: Many connections formed between objects that create a strong network of bonds.

Program-Specific background:

- Material Science & Engineering:

The field of materials engineering is often the bottleneck of new discoveries. By inventing new technologies such as hydrogels, we can revolutionize already existing areas of medicine. For example, we can take existing medicines and use hydrogels as a method of delivery, as opposed to how they are traditionally administered. Additionally, existing fabrication methods can be combined with hydrogels to create new applications. For example, bioprinting combines traditional 3D printing techniques with hydrogels as a material. The ability to control the structure of the hydrogel allows for fine tuning of its material properties and interactions.

- Interdisciplinary Design:

Like many aspects of biomedical engineering, the creation and application of hydrogels is a collaborative process between multiple fields of engineering. For example, when designing hydrogels for drug delivery, both a biological/pharmacological and material science perspective must be taken. The interactions between the engineered material and body must be considered, as well how the drug absorption changes with this new delivery mechanism. This interdisciplinary work is core to many applied fields of research such as those in BME. Knowing how to collaborate with others who have different knowledge and skills than you is an essential skill.

[1] Q. Chai, Y. Jiao, and X. Yu, "Hydrogels for Biomedical Applications: Their Characteristics and the Mechanisms behind Them," *Ge/s*, vol. 3, no. 1, p. 6, Jan. 2017, doi: [10.3390/gels3010006](https://doi.org/10.3390/gels3010006)

**Conclusions/action items:**

Submit proposal and plan outreach activity for next semester.



## 2023/12/13 - WARF Innovation Disclosure

---

Mateo Silver - Dec 13, 2023, 3:48 PM CST

**Title:** WARF Innovation Disclosure

**Date:** 12/13/2023

**Content by:** Mateo

**Present:** n/a

**Goals:** Learn about how to disclose our project to WARF

**Content:**

During our most recent client meeting, our client expressed interest in us contacting WARF to disclose our idea. I have begun to investigate how we would go about that and what materials we would need to prepare.

- According to the WARF website [1], the first step in their process is to disclose our innovation
- This is a simple form on their website where we would include a description of our invention, the gap in the market it fills, and our plans for commercialization.
- In the form we must also disclose any events/presentations where we exhibited our product to the public.
- Following submission of the disclosure, WARF may invite us to a confidential meeting where we discuss the details of our device and how WARF could help us.
- Next, our proposal would be reviewed by an internal committee, and evaluate potential conflicts of interest.
- If the proposal is approved, the next step would be entering a legal contract with WARF. This grants us a portion of royalty income in exchange for the intellectual property.
- Finally, we would collaborate with WARF's patent agents to write our patent application.

Some other relevant information I found regarding WARF is:

- the price of a patent is around \$20-40k, considering the cost of a patent attorney and the resources that went into creating the application
- WARF covers the entirety of legal costs and fees during the patent filing process.
- The group that files the patent receives a total of 20% of royalty income, this is divided between all the patent holders.

[1] <https://www.warf.org/invent/disclose-an-invention/>

**Conclusions/action items:**

Move forward with working with WARF next semester.



## 2023/09/13 - Anatomy and Physiology of Cricothyroidotomy

---



**Title: Cricothyroidotomy Information (Anatomy and Physiology)****Date:** 9/13/2023**Content by:** Megan Finell**Present:** N/A**Goals:** Understand the anatomy behind this procedure and equipment used to complete it.**Content:**

As used today, cricothyroidotomy is the surgical rescue technique of choice for the failed airway in adults. It is the final step in the emergency airway management algorithm and is necessary during a CICO scenario (cannot intubate, cannot oxygenate). Not intervening in this scenario could lead to brain hypoxia and patient death.

**Basic anatomy:**

- cricothyroidotomy is performed by inserting a tube through an incision in the cricothyroid membrane
- cricothyroid membrane (CTM)
  - bordered superiorly by the thyroid cartilage, inferiorly by the cricoid cartilage, and laterally by the bilateral cricothyroid muscles
  - approximately 2 cm inferior to the laryngeal prominence and superior to the cricoid cartilage

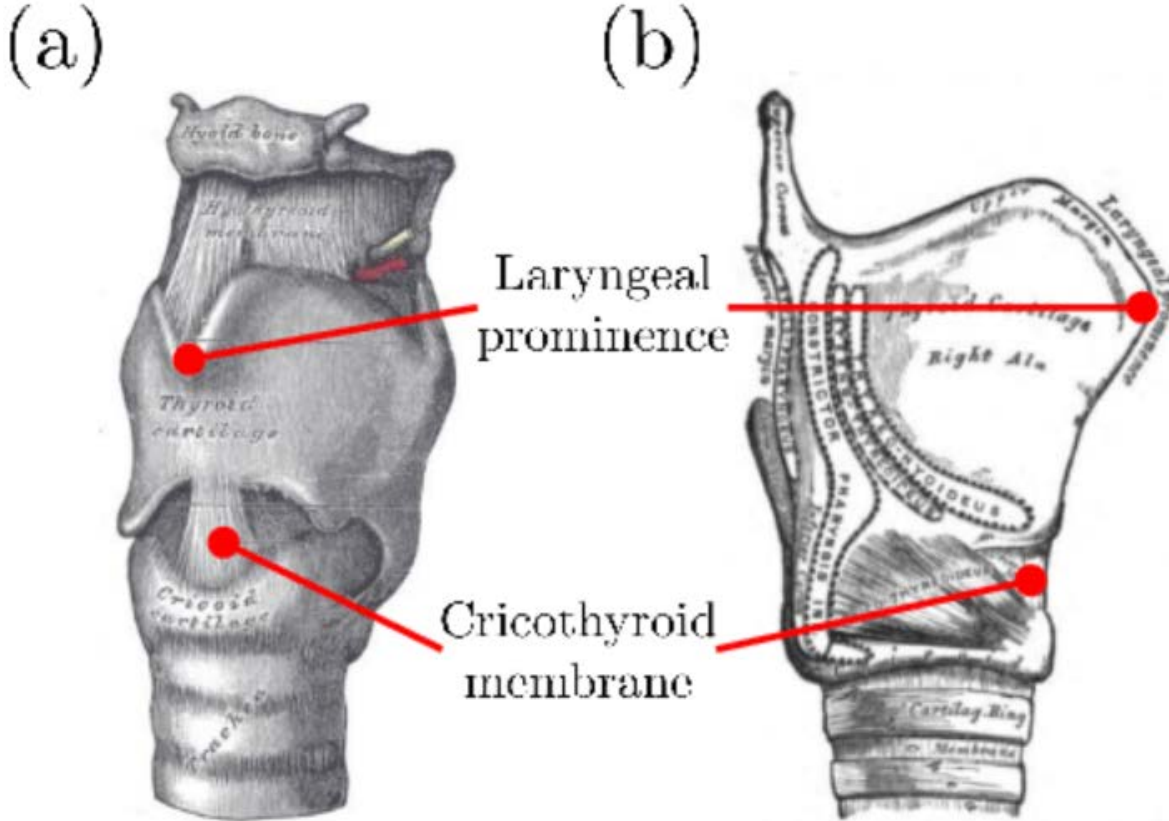
**Equipment used in the procedure:**

- Yankauer suction
- scalpel (usually #20 blade)
- gum elastic bougie
- cuffed tracheostomy tube 6.0
- ten cc syringe
- securement device
- ventilator and tubing

Source: [Cricothyrotomy - StatPearls - NCBI Bookshelf \(nih.gov\)](#)**Conclusions/action items:**

Research the procedure and steps in the treatment. Also look for common issues and complications related to the process to better understand how to improve it.



## 2023/09/13 - Complications of Cricothyroidotomy

---

Megan Finell - Sep 13, 2023, 3:16 PM CDT

**Title:** Complications of cricothyroidotomy versus tracheostomy in emergency surgical airway management: a systemic review

**Date:** 9/13/2023

**Content by:** Megan

**Present:** N/A

**Goals:** Learn about the history cricothyroidotomy, when it's used, and how it differs compared to tracheostomy.

**Content:**

Surgical airways can be achieved through both a cricothyroidotomy and a tracheostomy.

- the case study concludes that cricothyroidotomies performed in emergency situations resulted in fewer late complications than tracheostomies
  - emergency cricothyroidotomies should be converted to tracheostomies in a timely fashion
    - insufficient evidence to suggest that emergency cricothyroidotomies are long term airways
- currently, there is limited evidence supporting the preferred emergency surgical airway technique in literature
- tracheostomies
  - all performed in a hospital setting, and mainly by surgeons
- cricothyroidotomies
  - performed in both pre- and intra- hospital settings, by both physicians and non-physicians

Cricothyroidotomies occur when intubation is not possible (ex. when the patient is choking). Therefore, they are relatively rare, but occur much more often in a non-hospital setting. This is important to consider for our design because it needs to be accessible and safe in a broad range of environments, and also many different people.

**Source:** [Complications of cricothyroidotomy versus tracheostomy in emergency surgical airway management: a systematic review - PMC \(nih.gov\)](#)

**Conclusions/action items:**

Research the training necessary to use current devices used in cricothyroidotomy along with the users.



## 2023/10/19 - Tracheal Anatomy

---

**Title: Anatomy, Head and Neck, Trachea****Date:** 10/19/2023**Content by:** Megan**Present:** N/A**Goals:** Understand the force needed to get through the structures on the anterior side of the trachea and if there are any structures in the immediate area that must be avoided.**Content:**

After seeing the original 3D printed prototype of our design, I wondered if it would be able to puncture the structures on the way to the trachea. This page include a lot of information on the general anatomy of the trachea and neck, which I found really useful.

Trachea:

- U shaped structure that is composed of hyaline cartilage on the anterior and lateral walls
- The trachealis smooth muscle forms the posterior border of the trachea
- The entire tracheal lumen is lined by ciliated pseudostratified columnar and goblet cells
  - Creates the tracheal mucosa
- The trachea is connected to the cricothyroid cartilage by the cricotracheal ligament
- Before it splits into the bronchi, there are about 16 to 20 hyaline cartilage rings
  - Each individually connected by annular ligament

Thoughts after reading:

- The trachea is lined with mucosa (we need to make sure that the holes for the airway in our device will not be affected or jeopardized)
- The posterior side of the trachea is not stiff
  - This is due to food going down the esophagus, which is found posteriorly to the trachea
- There are both blood vessels and lymphatic vessels running longitudinally along the trachea (and esophagus)
  - The vascular capacity of the lungs would be compromised if our device accidentally punctured one, so it is important that users are able to correctly identify the puncture spot
- The trachea's back wall is made of muscle, and the front (anterior) side is made of cartilage
  - Cartilage will most likely be more difficult to puncture than smooth muscle
    - It is really important that our device does not hit the vulnerable back wall of the trachea

Source:

[Anatomy, Head and Neck, Trachea - StatPearls - NCBI Bookshelf \(nih.gov\)](#)**Conclusions/action items:**

I'm learning about cartilage in two of my classes right now, and it is a relatively strong tissue. I want to research how strong the hyaline cartilage of the trachea is and the force needed to puncture it. This is important to understand so that the team can make improvements to the design, allowing the user to generate the necessary force.



**2023/10/26 - Cartilage notes from BME 615**

---

**Title: Tissue Mechanics BME615 Notes on Cartilage**

**Date:** 10/26/2023

**Content by:** Megan Finell

**Present:** N/A

**Goals:** Get an understanding of the forces needed to puncture cartilage in the trachea/cricothyroid area.

**Content:**

This is taken from a lecture on cartilage tissue mechanics given by Dr. Corrine Henak in BME615.

- cricoid cartilage, tracheal cartilage, and thyroid cartilage are all hyaline (glassy cartilage)

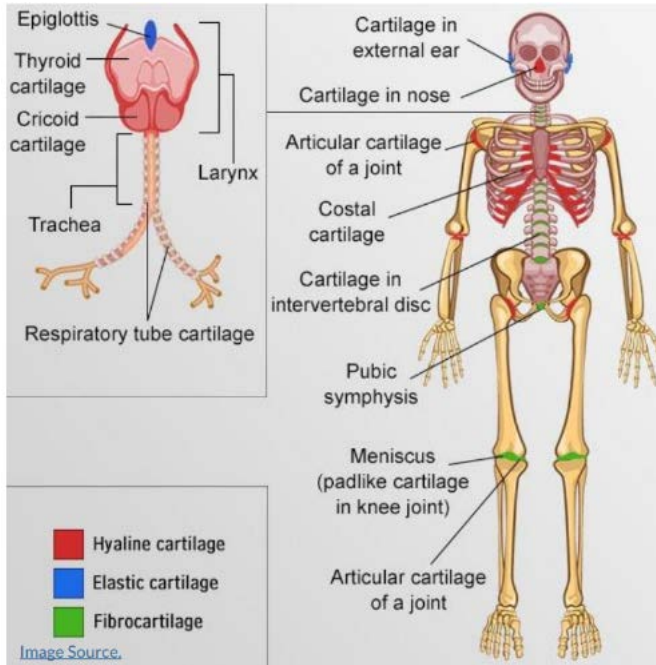

- articular cartilage is composed of about 80% water and 20% extracellular matrix and cells
  - chondrocytes, collagen, and proteoglycans and glycosaminoglycans
  - orientation of collagen fibers and relative amounts of PGs and GAGs

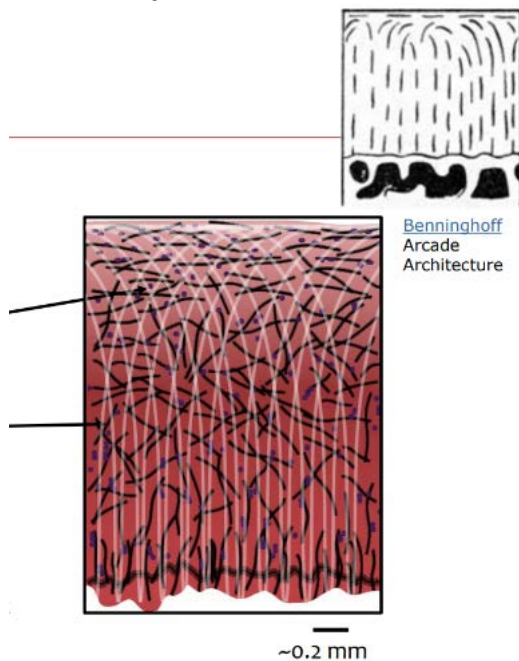

- type II collagen fibers are typically the main type found in hyaline cartilage
  - on the 50 nm - 150 nm scale
- articular cartilage material symmetry

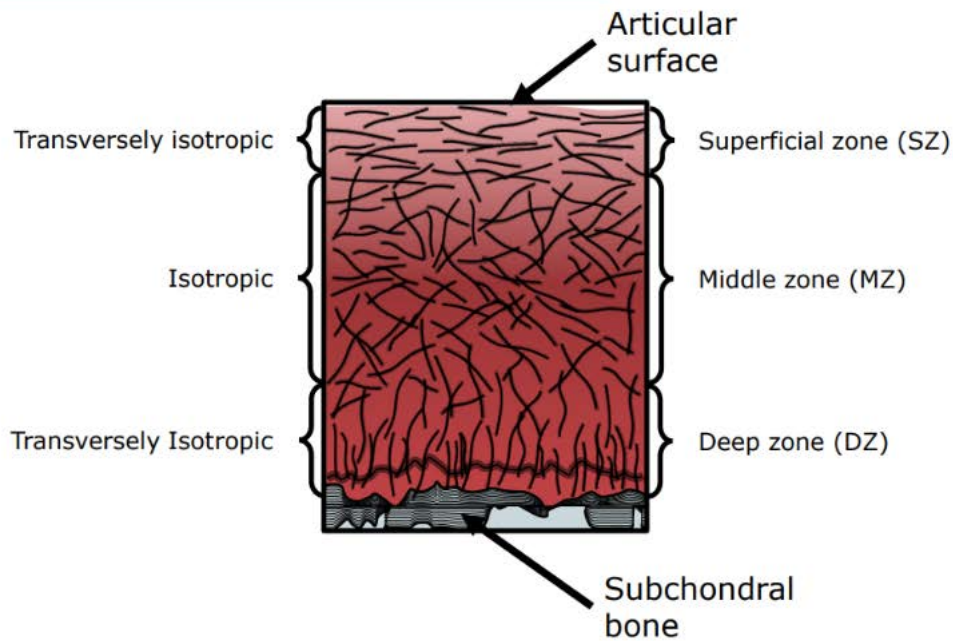

- 
- cartilage is stronger under compression than tension
- cartilage -to-cartilage contact
  - peak 10 MPa
  - walking is about 5-6 MPa
  - Does this have similar force resistance to puncturing?
    - I don't think so, this is a LOT of force (10 Mpa = 208854 lbf/ft<sup>2</sup>)

#### Conclusions/action items:

When listening to this lecture, a lot of questions came to my mind about how the material properties indicate how much force will be needed to puncture the membrane and cartilage on the wa the trachea. It's also easier to see by fiber arrangement why initially puncturing cartilage (probably most materials) is harder at first and then gets easier due to fiber alignment in the deep zone

If the team has questions about the mechanical properties of cartilage we will be puncturing through and how to best design the device to easily cut, Dr. Henak could potentially be very helpful





**2023/09/26- Surgicric Cricothyroidotomy Device**

---

**Title:** Evaluation of a novel Surgicric® cricothyroidotomy device for emergency tracheal access in a porcine model

**Date:** 09/26/2023

**Content by:** Megan Finell

**Present:** N/A

**Goals:** Get an understanding of current products on the market, what they are made of, and think of how to improve upon them.

**Content:**

In this study, 3 devices were tested to determine the efficiency of completing cricothyroidotomies.

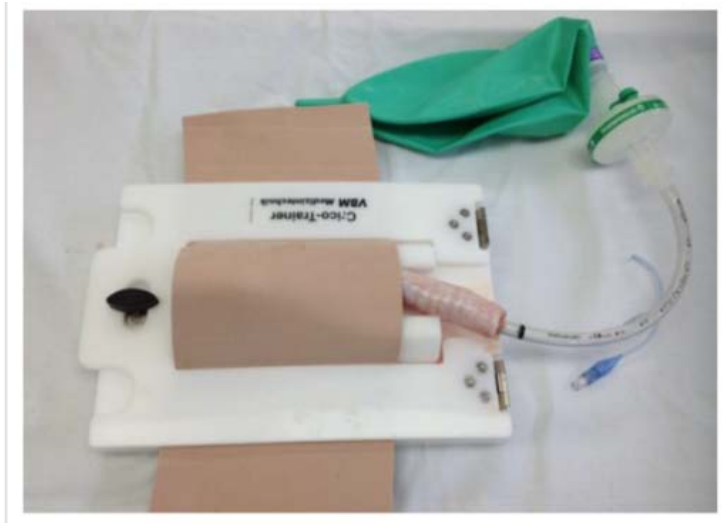

- Procedure was performed on a porcine model setup (pig larynx & trachea, with artificial skin over the top, connected to a simple lung simulator)
- Participants were required to have previous knowledge of basic emergency cricothyroidotomy training, and watched short videos
- Participants each performed cricothyroidotomy with all 3 devices
  - Surgicric device
    - 7.0 mm cuffed tracheal tube, scalpel (size 20), tracheal hook, 5ml syringe, necktape, extension tubing



- Melker cricothyroidotomy
  - 5.0 mm cuffed airway tube, catheter introducer needle, scalpel, guidewire, 5ml syringe



- Surgical Technique
  - common equipment from the workplace
  - scalpel (size 20), tracheal hook, tracheal dilator, size 6.0 mm cuffed tracheal tube

**Results:**

- Successful outcome was determined by the time taken to correctly place the cricothyroidotomy device into the trachea
  - Also determined by number of attempts required to insert each device and degree of tracheal damage
- Trauma results
  - Highest occurrence of trauma with the Surgicric, least with the surgical technique
- Time results
  - Longest time taken on average was with the Melker device, least with the surgical technique
  - Most took 100-200 seconds

**Final thoughts on the Surgicric device:**

- Associated with the greatest amount of trauma and highest failure rate
  - could be due to the stiffness of the Surgicric, insertion force, device diameter, and curvature
- Changes made to the Surgicric after this study
  - diameter changed from 7mm to 6mm
  - device is not made with the DEHP plasticiser (which is used in PVC), resulting in a softer, more compliant device

**Website/citation:**

[Evaluation of a novel Surgicric® cricothyroidotomy device for emergency tracheal access in a porcine model - King - 2016 - Anaesthesia - Wiley Online Library](#)

**Conclusions/action items:**

This study brought to mind several factors surrounding design ideas. It is useful to have the information on how the Surgicric failed, and how it was improved. These are points that I will keep in mind when brainstorming ideas and materials.



## 2023/10/12- Plastics with outstanding mechanical properties

---

Megan Finell - Oct 19, 2023, 10:35 PM CDT

**Title: Strong and Stiff: Plastics with outstanding mechanical properties**

**Date:** 10/12/2023

**Content by:** Megan

**Present:** N/A

**Goals:** Understand more about engineering polymers and determine some options for possible final materials

**Content:**

This page highlights many different types of plastics, which I used to narrow down my ideas for materials.

- Various possibilities:
  - Acetal
    - High strength, stiff, low friction engineering plastic with good wear properties
    - Easy to machine
  - Acrylic
    - Outstanding strong, stiff, clear plastic
    - Exhibits glass-like qualities, but at half the weight and many times the impact resistance of glass
    - Easy to fabricate, machine, and thermoform
  - High impact polystyrene
    - Low cost, tough plastic, easy to thermoform and fabricate
  - Polycarbonate
    - Tough, transparent
    - Outstanding strength, stiffness, and impact resistance
    - Easy to fabricate and machine

Many plastics seem relatively cheap and also easy to machine. In addition to these factors, it is important that our device be biocompatible, have impact resistance, and have the ability to be sharpened.

Additional plastics are listed on this website with their respective qualities as well.

Source:

[Strong, Stiff, Hard Plastics | Curbell Plastics](#)

**Conclusions/action items:**

This was a great starting point for looking into the materials properties of plastics that are available. I want to do more research on commonly 3D printed plastics because that is most likely how we are prototyping. I think that it is important that our first few prototypes are cheap but not at the compromise of possible properties the team would like our device to exhibit.



## 2023/10/27 - Skin model materials

Megan Finell - Oct 27, 2023, 11:28 AM CDT

**Title:** Materials used to simulate physical properties of human skin

**Date:** 10/27/2023

**Content by:** Megan Finell

**Present:** N/A

**Goals:** Understand the different types of skin models available for testing and their pros and cons.

**Content:**

Basic background:

- skin is a very complex active open system consisting of highly inhomogeneous and anisotropic composite materials
- strong simplifications in models that do not reflect the structure and the composition of the human skin
- models consisting of liquid suspensions, gelatinous substances, elastomers, resins, metals, and textiles incorporating nano- and micro-fillers
  - also uncommon skin models such as those based on albumen, or engineered skin models

Pros to skin models vs using organic tissue:

- physical skin models allow obtaining long-term stability, lower costs, easy storage and manipulation and a better control over their physical properties
- better reproducibility and reliability
- devoid of ethical issues involved with organic tissue

Types of polymers commonly used that could be beneficial for our purposes:

- elastomers
  - polymers exhibiting rubber-like viscoelastic properties
  - allow tailoring the physical properties of skin models within a wide range
  - human skin is primarily simulated by means of silicones and polyurethane
- silicones
  - inorganic-organic polymers containing Si, O, C, and H
  - has a refractive index similar to skin (1.3–1.5)
  - skin models containing silicone are durable over long time periods and can be molded to obtain various shapes from simple geometries to anatomical shapes
  - broad range of properties that can be simulated, easy manipulation, nontoxicity during and after preparation, and long-term stability
  - silicone based skin models have been introduced to simulate skin in numerous applications such as optical imaging, measurement of the specific absorption rate, drug delivery, needle penetration, acoustic and photoacoustic imaging, tactile assessment, indentation, and friction

Overall, most skin models are adopted through a trial-and-error process by using materials that look, feel, and have a structure or composition similar to skin.

Source:

[Materials used to simulate physical properties of human skin - Dąbrowska - 2016 - Skin Research and Technology - Wiley Online Library](#)

**Conclusions/action items:**

The team was thinking of using the artificial skin that is in the BME blue lab supply closet for testing. I want to look at what type of material it is to see what properties it has.



## 2023/10/27 - Common Metals found in Surgical Instruments

---

**Title: The 11 Most Important Metals Used in Medicine****Date:** 10/27/2023**Content by:** Megan Finell**Present:** N/A**Goals:** Think of the best metals to possibly use for our design and get an understanding of their properties before consulting with TEAM lab on Tuesday.**Content:**

Surgical metals have to meet engineering requirements of the application and be biocompatible with the human body.

- non-toxic in the presence of human tissue or fluids
- resist chemicals used for sterilization
- metals for implants must be non-magnetic and non-corrosive

11 Types of Metal commonly used in surgical instruments:

1. Stainless Steel

- non-toxic, non-corrosive, durable, and can be polished to a very fine finish so that it's easily cleaned
- in surgical tools:
  - most are made from 440 stainless steel (higher carbon content means it can be heat treated to create very sharp edges for cutting)
  - used for tweezers, forceps, hemostats, and other durable equipment

2. Copper

- ideal for surfaces that are constantly being touched (outstanding antiviral and antibacterial properties)

3. Titanium

- common substitute for stainless steel to make skeletal supports and bone replacements

4. Cobalt Chrome

- used for joint replacements and for dental implants

5. Aluminum

- seldom used in direct contact with the body
- very commonly employed for various types of support equipment that must be light, strong, and corrosion-resistant

6. Magnesium

- very lightweight yet strong
- naturally and safely biodegrade, so it can be used for temporary stents or bone graft replacements where it will dissolve over time

7. Gold

- good corrosion resistance and biocompatibility
- expensive and rare, and is usually limited to very thin platings instead of solid gold

8. Platinum

- biocompatible and is also an excellent conductor
- used for internal electronic implants, such as pacemakers and hearing aids

9. Silver

- naturally antimicrobial
- useful for stents and non-load-bearing implants

10. Iridium

- used to coat the wiring used for electro-stimulation devices.

11. Tantalum

- high heat resistance, good workability, acid, and corrosive resistance, ductility and strength

**Conclusions/action items:**

After reading this article and thinking about possible non-ferrous metals to use for prototyping, I think that stainless steel or aluminum shows the most promise. I want to do more research over the weekend about pricing of metals and their machineability.



## 2023/09/27- Design 1

Megan Finell - Sep 27, 2023, 5:46 PM CDT

**Title:** Design Idea 1: Retractable Blade Device

**Date:** 09/27/2023

**Content by:** Megan Finell

**Present:** N/A

**Goals:** Describe my first design idea.

**Content:**

### Design Idea 1 - Retractable blade device

- has a retractable push-button blade
- 2 depths (for adults/children) could be achieved using a similar mechanism of a micro pipette
- made completely of plastics (possibly a glass blade)
- When blade retracts, the inner tubing is inserted slightly into the trachea to hold open the airway

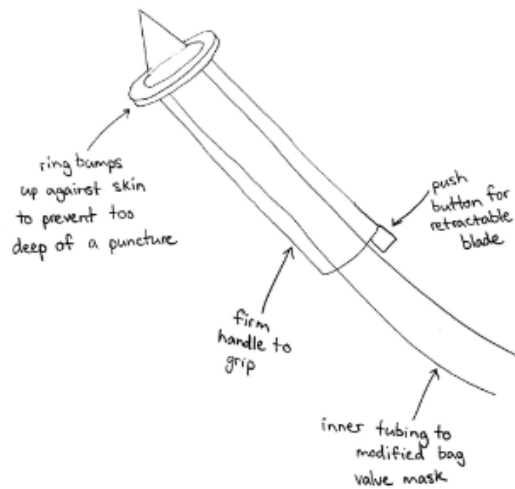

How to use:

1. Take out of packaging
2. Deploy the blade with push button
3. Puncture skin and trachea with downward force
4. Push button to insert tube and retract blade
5. Breathe through tube or connect to a bag valve, wait for paramedics to arrive.

**Conclusions/action items:**

Share design idea with the team.



Design Idea 1 - Retractable blade device

- has a retractable, push-button blade
- 2 depths (for adults/children) could be achieved using a similar mechanism of a micro pipette
- made completely of plastics (possibly a glass blade)
- when blade retracts, the inner tubing is inserted slightly into the trachea to hold open the airway

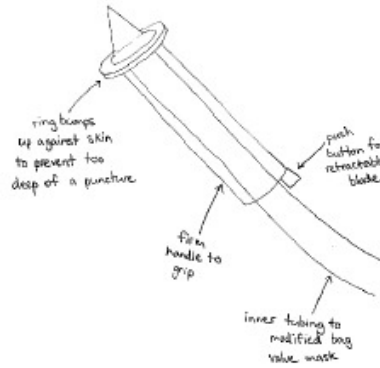

[Download](#)

**BME400\_Design\_1.pdf (333 kB)**



## 2023/09/27- Design 2

Megan Finell - Sep 27, 2023, 5:50 PM CDT

**Title:** Design Idea 2: Angle Cut Device

**Date:** 09/27/2023

**Content by:** Megan Finell

**Present:** N/A

**Goals:** Describe my second design idea.

**Content:**

I designed this with the idea that inserting at a slant would help prevent hitting the back wall of the trachea, while still allowing the user to use enough force to puncture.

### Design Idea 2

- similar to the crude prototype that our client has
- device is inserted at a slant to prevent hitting the back of the trachea
- made entirely of plastic
- slanted stop disk acts as a guide to the user for angle of insertion

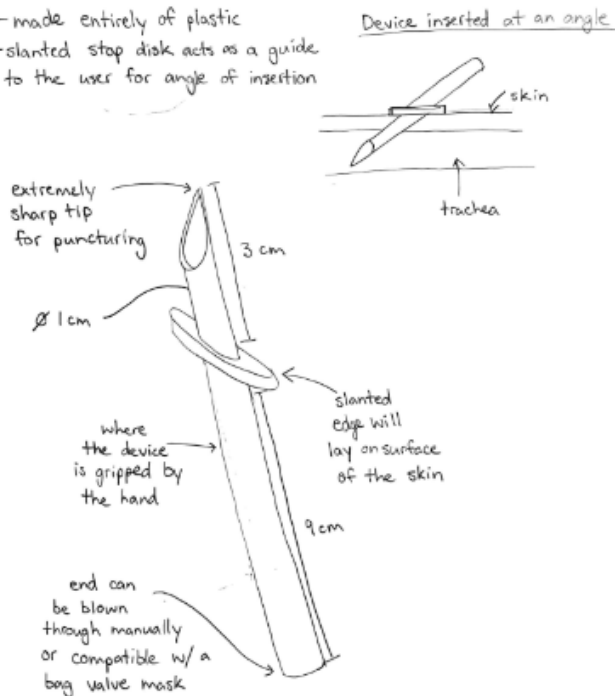

How to use:

1. Take out of packaging
2. Insert device at angle so that stopping disc is parallel with the trachea
3. Breathe through tube or connect to bag valve
4. Wait for paramedics to arrive.

**Conclusions/action items:**

Share design idea with the team.

Design Idea 2

- similar to the crude prototype that our client has
- device is inserted at a slant to prevent hitting the back of the trachea
- made entirely of plastic
- slanted stop disk acts as a guide to the user for angle of insertion

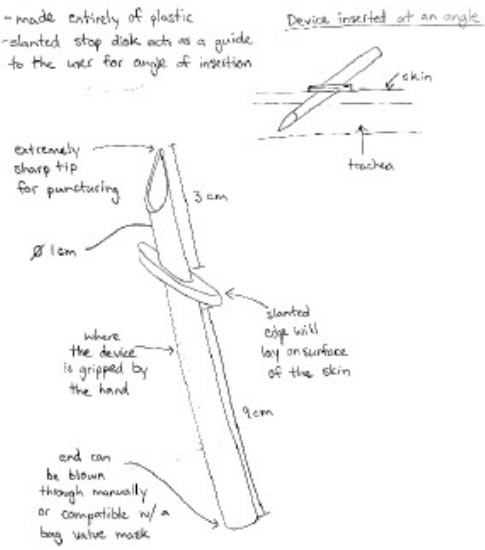
[Download](#)**BME400\_Design\_2.pdf (353 kB)**



**2023/09/27- Design 3**

---

**Title:** Design Idea 3: Puncture Stick Device

**Date:** 09/27/2023

**Content by:** Megan Finell

**Present:** N/A

**Goals:** Describe my third design idea.

**Content:**

I designed this to operate with a similar mechanism to a lancet (used when drawing blood). When pricking the finger, the lancet deploys a blade from pressure against the skin or a push button. This design uses the idea of pressure to move the cap, which slides back while exposing the blade. The blade does not move within the device.

### Design Idea 3 - Puncture Stick Device

- this device operates similarly to how a lancet is used to draw blood
- safe for the user because the sharp blade is not exposed at any time except when in the trachea
- device is placed against the skin and pressure is applied, then the cap slides back while the blade is exposed & punctures the skin
- made of plastic

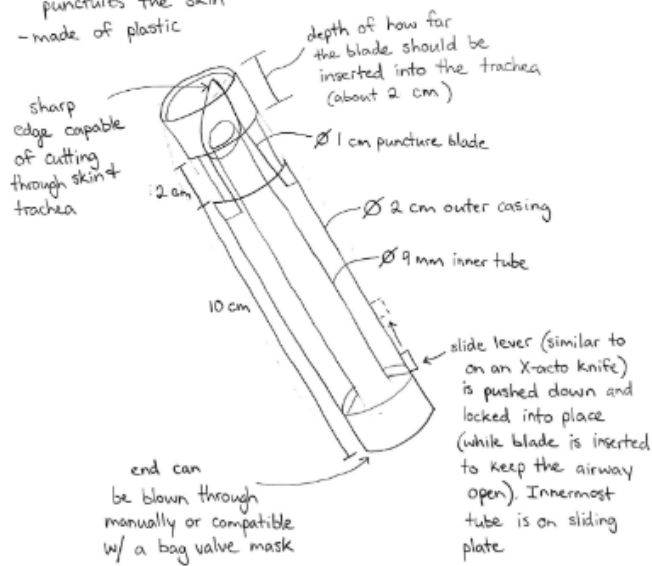

How to use:

1. Take out of packaging
2. Grip and place against skin
3. Assert downward pressure, cutting into the skin and trachea
4. Slide the lever down (towards the patient), locking the inner tube into place (now inserted into the trachea).
5. Gently remove pressure until the outer casing returns to its original length.
6. Breathe through tube or attach to bag valve, wait for paramedics to arrive.

**Conclusions/action items:**

Share design idea with the team.

Design Idea 3 - Puncture Stick Device

- this device operates similarly to how a lancet is used to draw blood
- safe for the user because the sharp blade is not exposed at any time except when in the trachea
- device is placed against the skin and pressure is applied, then the cap slides back while the blade is exposed & punctures the skin
- made of plastic

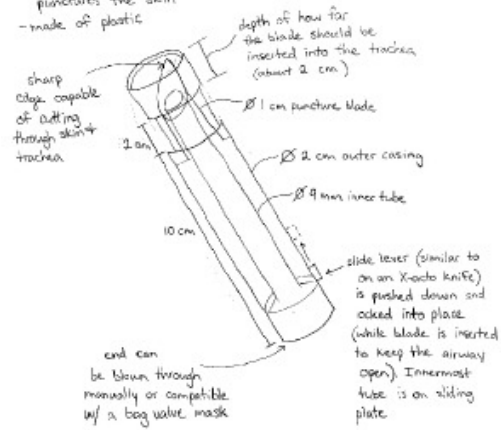

[Download](#)

**BME400\_Design\_3.pdf (399 kB)**



# 2023/12/13- Drawings for Instructions

---

**Title: Instructions to Palpate the Cricothyroid Membrane**

**Date:** 12/13/2023

**Content by:** Megan Finell

**Present:** n/a

**Goals:** Make drawing for show and tell instructions. I drew these and made the document in November.

**Content:**

- my goal was to make simple drawings that allow people to quickly and accurately find the cricothyroid membrane

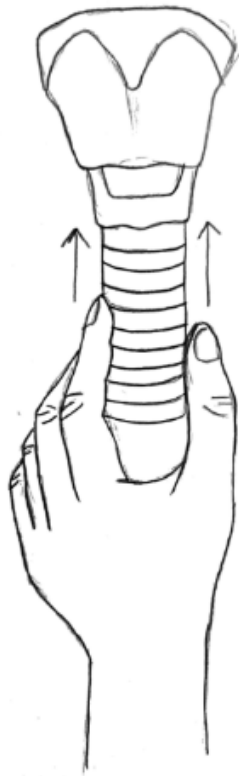



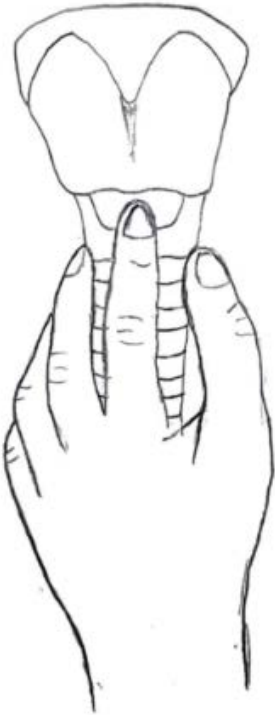

## INSTRUCTIONS TO PALPATE THE CRICOTHYROID MEMBRANE

**1**

Caress the patient's trachea using your middle finger and thumb, sliding your fingers up the trachea toward the patient's chin.

**2**

Move fingers up until you feel a thin harder band protruding out about halfway up the patient's neck.

**3**

Using your pointer finger, put your finger on the band and slide it towards the chin until it falls into a gap about the size of the tip of your finger.

### Conclusions/action items:

At show and tell, we showed these to other BME students. We surveyed them on how fast they could find the cricothyroid membrane, and most of them could do it in about 1.5 minutes.



## 9/26/2023 - Chemistry and Biohazard Safety Training

Megan Finell - Sep 26, 2023, 8:39 PM CDT

**Title:** Chemistry and Biosafety Training Certification

**Date:** 9/26/2023

**Content by:** Megan Finell

**Present:** N/A

**Goals:** Provide proof of completion of the chemistry training and the biosafety training.

**Content:**

Training Information Lookup Tool

University of Wisconsin-Madison

 WISCONSIN  
UNIVERSITY OF WISCONSIN-MADISON

This certifies that Megan Finell has completed training for the following course(s):

[Expand All](#) [Collapse All](#)

Course	Assignment	Completion	Expiration
Biosafety Required Training	Biosafety Required Training Quiz 2022	2/9/2022	
Chemical Safety: The OSHA Lab Standard	Final Quiz	1/30/2022	

Data Last Imported: 21/02/2022 09:50 PM

© 2022 Board of Regents of the University of Wisconsin System

11:31 PM 2/21/2022

**Conclusions/action items:**

Proof of chemistry and biohazard safety training (expires 2025).



# 9/26/2022 - Green Permit Training

Megan Finell - Sep 26, 2023, 8:41 PM CDT

**Title:** Green Permit Training Certification

**Date:** 9/26/2023

**Content by:** Megan Finell

**Present:** N/A

**Goals:** Provide proof that I completent my green permit training.

**Content:**

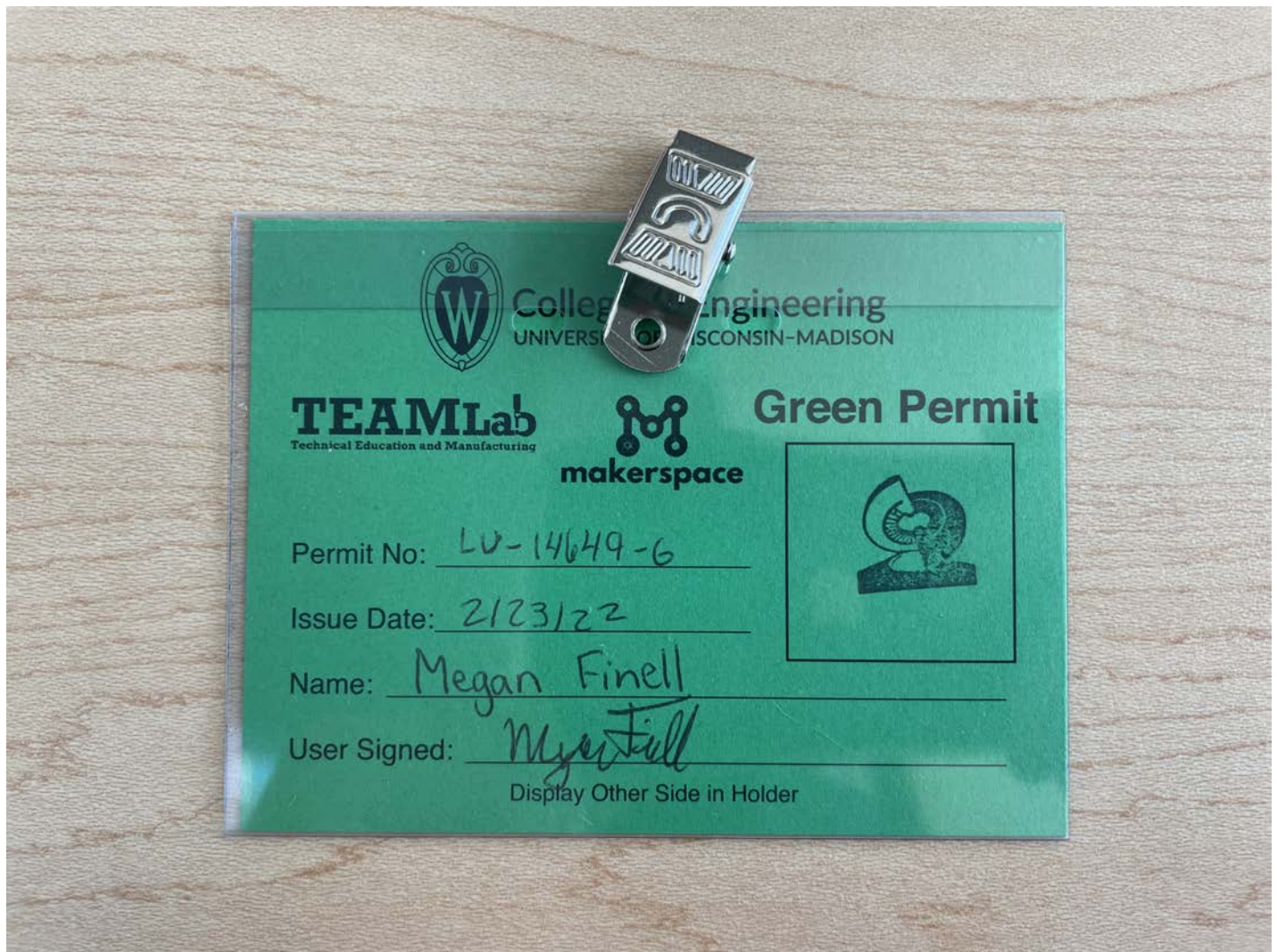

**Conclusions/action items:**

This permit allows me to use the mills and the lathes in TEAM labs, so I can now do projects down there.



# 2023/12/13- Fabrication on Lathe

---

**Title: Fabrication of Final Design on Lathe**

**Date:** 12/13/2023

**Content by:** Megan

**Present:** N/A

**Goals:** Taking notes on the fabrication process on the lathe.

**Content:**

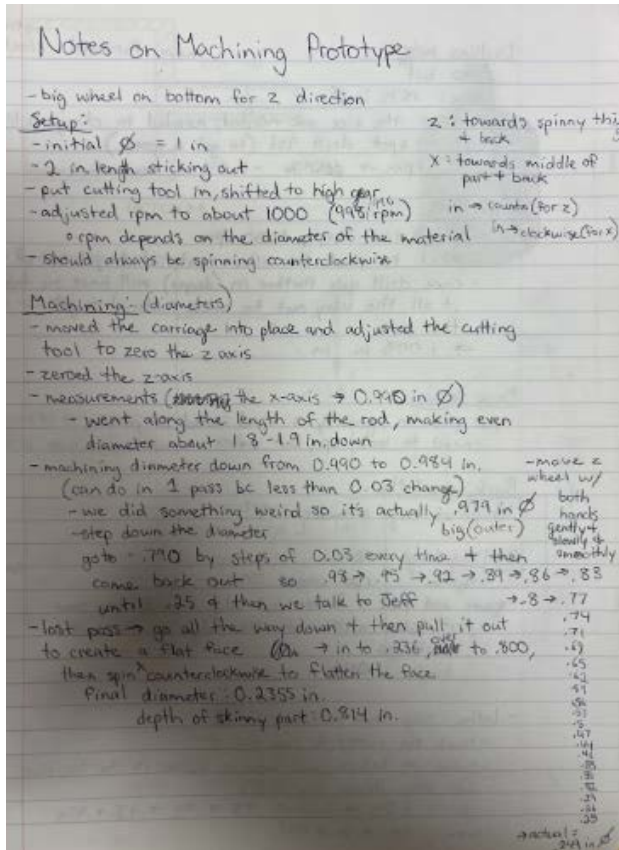

Drilling holes:

5/32 bit

rotate clockwise  
move forward

hole: .1575 in  $\phi$

(about the size we needed, needed to change a little)

- need to spot drill 1st (to get a groove)

800 rpm  $\rightarrow$  ~~1000~~ -0.04 in, readout

- drilling  
- about 1 in deep, 1000 rpm  
- need to peck to allow material to get out of hole (forward + back)  
- once drill gets further in (deeper) will have to take it all the way out to allow material to get out of the hole  
 $\rightarrow$  1.005 in. in

Drop saw

- put part in, gravity is used instead of pushing it through  
- need to look up, but valves are used, aluminum 200 rpm

Back on lathe  
length of large diameter: .9?

Drilling large hole:

- flight rpm: about 1000 rpm  
- square out part  $\rightarrow$  flatten out edge from the drop saw  
- just take a little off the edge w/ the cutter  
thickness  
length: 1.0146

- lathe step down to .900 in <sup>length</sup>

- touch the cutter & zero the Z

- same as before, just now Z value is the one that we step down by 0.03

1.04  $\rightarrow$  1.01  $\rightarrow$  .98  $\rightarrow$  .95  $\rightarrow$  .92  $\rightarrow$  .906

- moving the X in + out

- spot drill again (900 rpm, -0.04 in)

(touch point to part & then 0 it first)

- need special drill bit  $\rightarrow$  get from TEAM labs employees

- using 55/64 02 mm  $\rightarrow$  .8661 in  $\phi$  depth .7874 in

one hand - get to tip & zero ~~1000~~ rpm (275)

- go ~~slowly~~ slowly pecking

- need to use pointy tip first & then flat drill bit

- we had a few issues bc we lost our zero & had to rezero

(big brain engineering thinking)

\* drill was slightly too small  $\rightarrow$  wrong size

.751 in depth in w/ pointy 55/64 drill bit

- w/ flat drill  $\rightarrow$  lowest rpm possible (237 rpm)

- take down to .751 in depth (just flattens out the angle)

- deburr & file edges (on lathe) (both front & back)

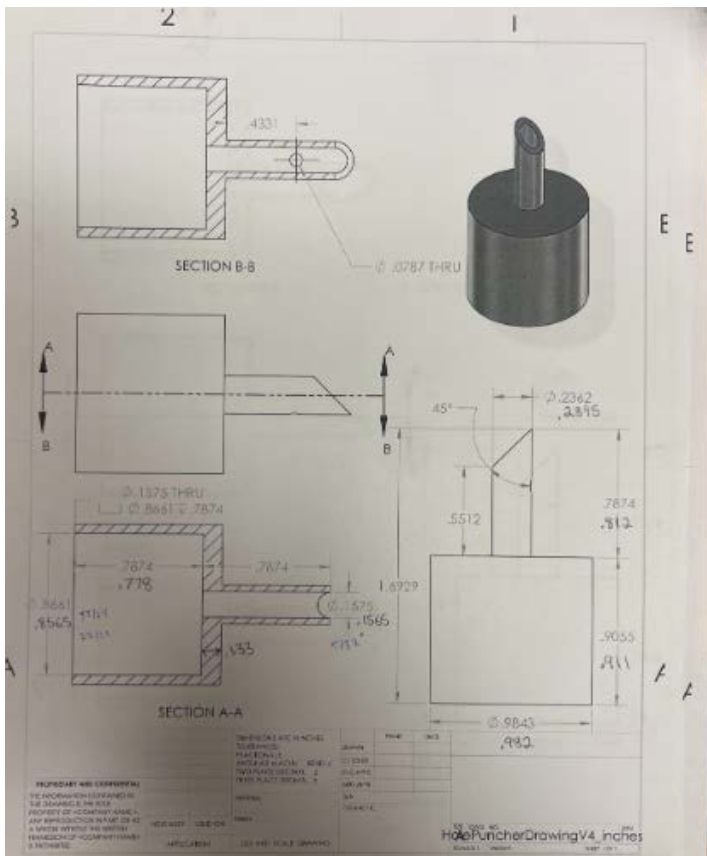

**Conclusions/action items:**

These are the notes I took on fabrication of the aluminum prototype while in TEAM labs.





**2023/12/13- MTS use notes**

---

**Title:** MTS machine use notes**Date:** 12/13/2023**Content by:** Megan**Present:** N/A

**Goals:** I found MTS machine protocol notes from a past course I have taken (ME 307 - Mechanics of Materials Lab) and we modified them to the testing that we did on the MTS machine.

**Content:**

This is tensile testing and not compression like we did, but it has some good descriptions about how to set up the grips/etc:



In this lab, we will conduct tensile tests on three different materials: A-36 mild steel, 6061 aluminum and cast iron. The specimens are cylindrical in shape. The overall dimensions are 0.5" diameter by 10" long, with a reduced machined test section of 0.335" diameter by 3.5" long.

The objectives of this lab are to develop stress-strain plots, and obtain elastic modulus, yield and ductility/brittleness information, maximum (ultimate) stress and fracture strength.

An extensometer will be used to record the steel strains. The extensometer is an expensive, and easily damaged, piece of equipment. A single steel specimen will therefore be tested under the close supervision of the instructor.

On the other hand, crosshead displacement will be used to determine the strains for the aluminum and cast iron specimens. Determining strains from crosshead displacements is simpler, but less reliable than using an extensometer. The aluminum and cast iron tests will be conducted by the students in small groups using the three identical machines.

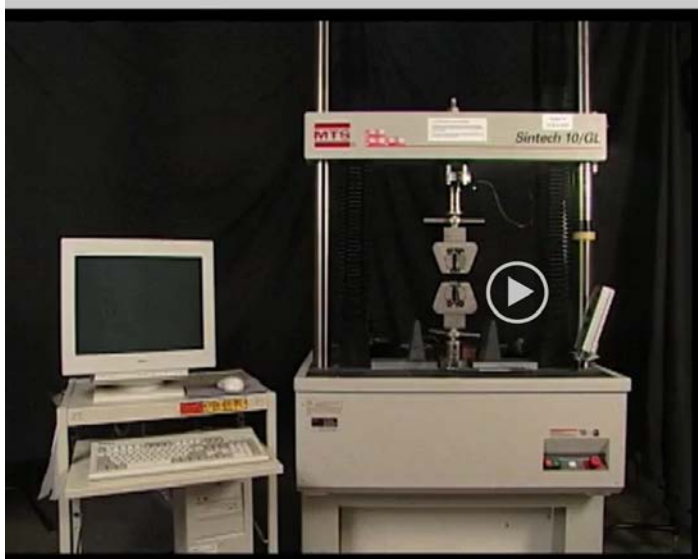

All tests in this lab are conducted using the MTS Sintech testing machines. They have a load capacity of 10,000 lbs. Each Sintech is controlled by its own computer with designated software for material testing.

The Sintech machines have a stationary bottom grip and a movable top grip. The top grip is attached to a crosshead which can be raised or lowered by threaded collars which engage rotatable, threaded columns. The gray frame between the columns is the crosshead. A switch on the handset will manually raise or lower the crosshead, to enable placing the specimen in the grips. With a specimen gripped in place, raising the crosshead loads the specimen in tension. Crosshead displacements, corresponding to the specimen deformation, and the associated load on the specimen, are plotted on the computer screen.

The instructor will conduct the first test with the steel specimen. The strains will be recorded using the external extensometer. The superior accuracy of the extensometer (over determining strains from crosshead displacement), plus the extensive yielding exhibited by the steel, renders this a good opportunity to demonstrate using an external extensometer.

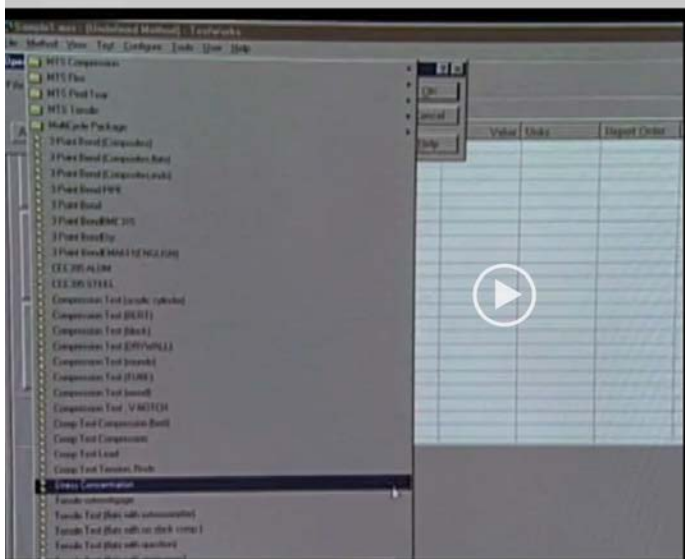

First, turn on the Sintech load frame by pushing the green button. The large red round button is for emergency shutdown. Do not use it for ordinary operation. Then turn on the computer. The monitor, in a dormant state, will automatically come on as the testing software loads.

Select CONTROL-ALT-DELETE for the Windows NT startup. Enter student as the user name. No password is required. The computer will open the general test software, TESTWORKS 4.

Another login screen also uses student as the login and NO password.

From the drop-down menu, "Open Method", the instructor will select for this first test: "Tensile Test (rounds with extensometer)". After completing this first test, the students will select another method: "Tensile Test (rounds)" to conduct the aluminum and cast iron tests. After making the selection, the operator will click OK to commence testing.

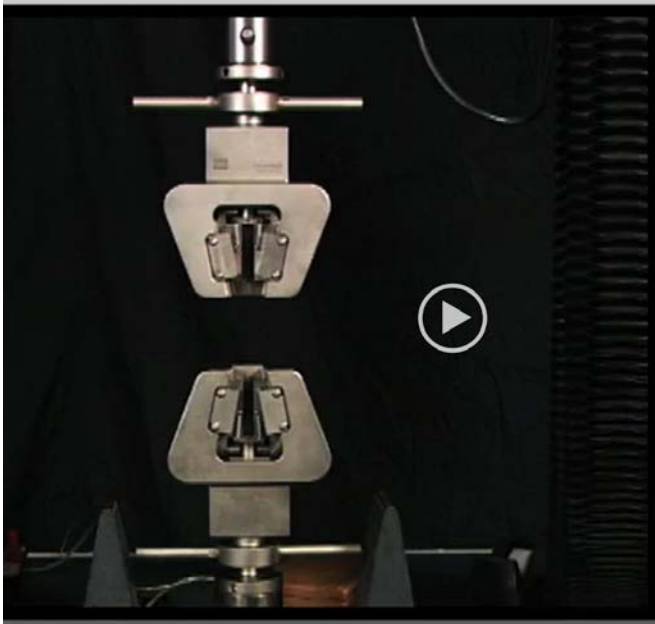

Wedge grips are used for round/cylindrical specimens. The specimen should be gripped at its top end before gripping its lower end. First, open both grips by rotating their handles. Raise the machine's crosshead sufficient to accommodate the specimen. The crosshead can be re-positioned using either the computer or the special handset. However, it is faster to use the handset to raise or lower the crosshead. Having adjusted the crosshead appropriately, position the specimen in the top and bottom grips. Center the specimen in the V of the grips. Tighten the top grip by rotating its handle to ensure the grip bites into the specimen. Grip as much of the large diameter area of the specimen as possible. However, make certain that the top of the top grip allows clearance beyond the top of the specimen. If the specimen extends too close to the top of the

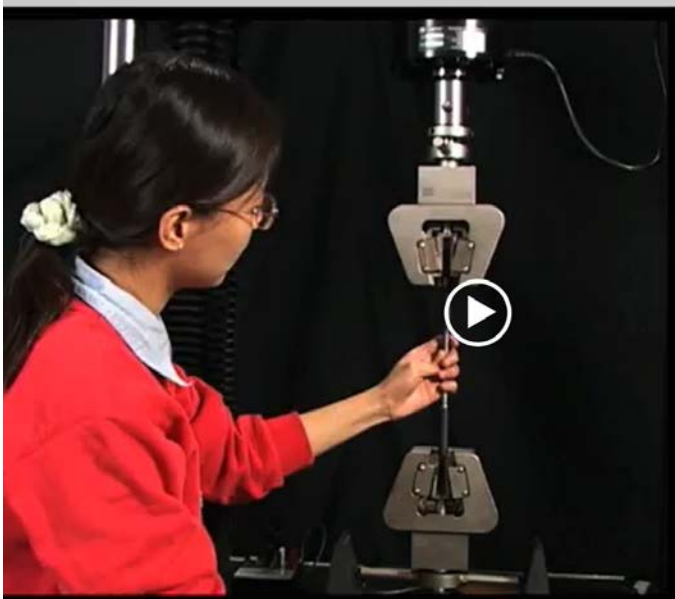

rotating its handle to ensure the grip bites into the specimen. Grip as much of the large diameter area of the specimen as possible. However, make certain that the top of the top grip allows clearance beyond the top of the specimen. If the specimen extends too close to the top of the top grip, that grip can be damaged when the specimen fails. Now lower the crosshead and specimen so the bottom of the specimen is appropriately located within the bottom grip. Before tightening the lower grip, re-zero the load. Right Click on the load meter on the screen and zero the load cell. You can zero the crosshead now, but this is NOT necessary, as it will be zeroed automatically at the start of every test. However, you must zero the load before the specimen is fully gripped. Grip as much of the large diameter

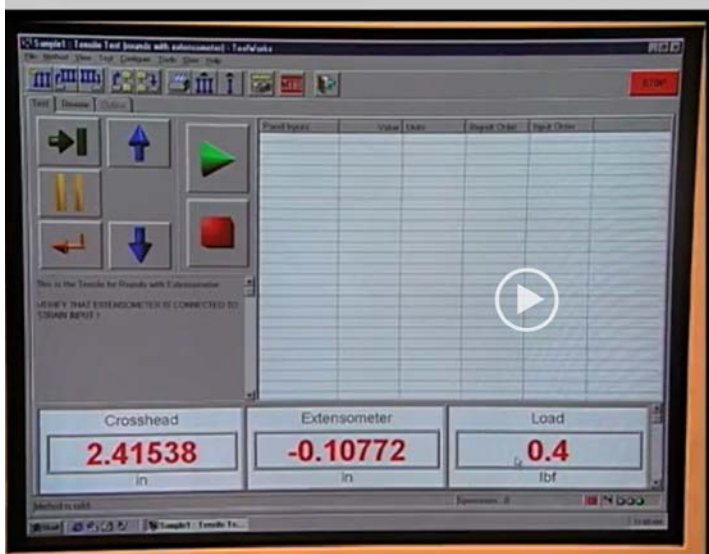

automatically at the start of every test. However, you must zero the load before the specimen is fully gripped. Grip as much of the large diameter area of the lower end of the specimen as possible, by rotating its handle. Leave a small amount of clearance beyond the bottom of the specimen and the bottom of the bottom grip. Tightening the bottom grip might apply a small tensile load, in this case about 14 lbs., to the specimen. This load is due to a slight downward movement of the wedges of the bottom grip when it is tightened. DO NOT re-zero the load at this point. Rather, eliminate or minimize this initial tensile load by lowering the crosshead slightly. Do so to come within a few pounds of zero. Such a slight residual pre-load is not a problem. At this stage, DO NOT re-zero the load.



At the computer, click on "run test". You will be asked for a sample ID. Remember the file name, because you will need it in order to retrieve your data from the hard drive. You will then be asked for specimen dimensions, the diameter of the reduced machine test section and the gage length(s).

The rest of this video isn't really applicable to the compression testing we performed.

**Conclusions/action items:**

Next semester, we should use this information to set up the MTS machine correctly while testing our prototype.



# 2023/12/13- Pictures from MTS testing

---

**Title: Pictures from MTS Testing**

**Date:** 12/13/2023

**Content by:** Megan

**Present:** N/A

**Goals:** Document the MTS Testing through pictures.

**Content:**

Larynx/trachea with the cricothyroid membrane exposed:



Prototype testing with trachea:

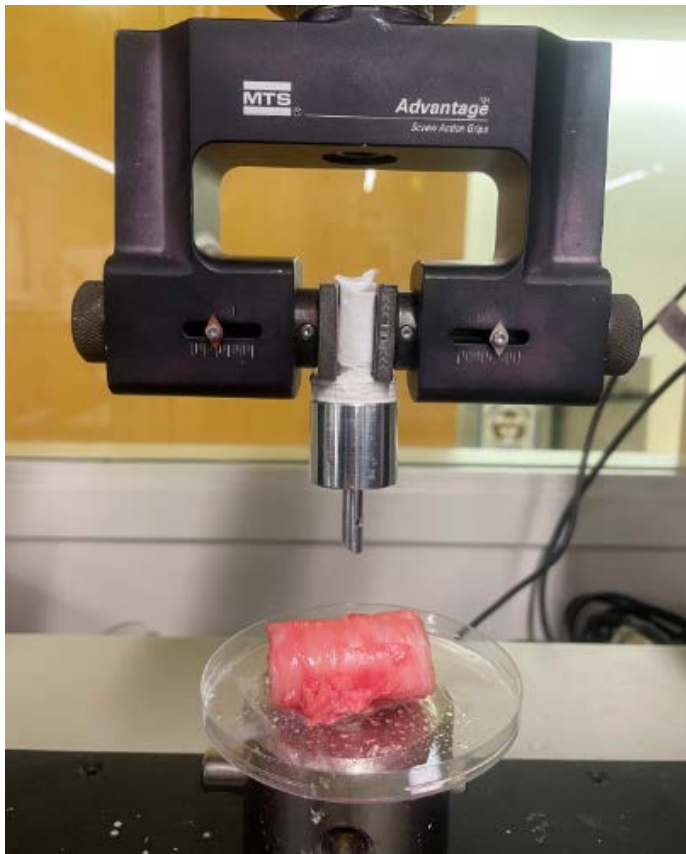

How we tried to secure the trachea:

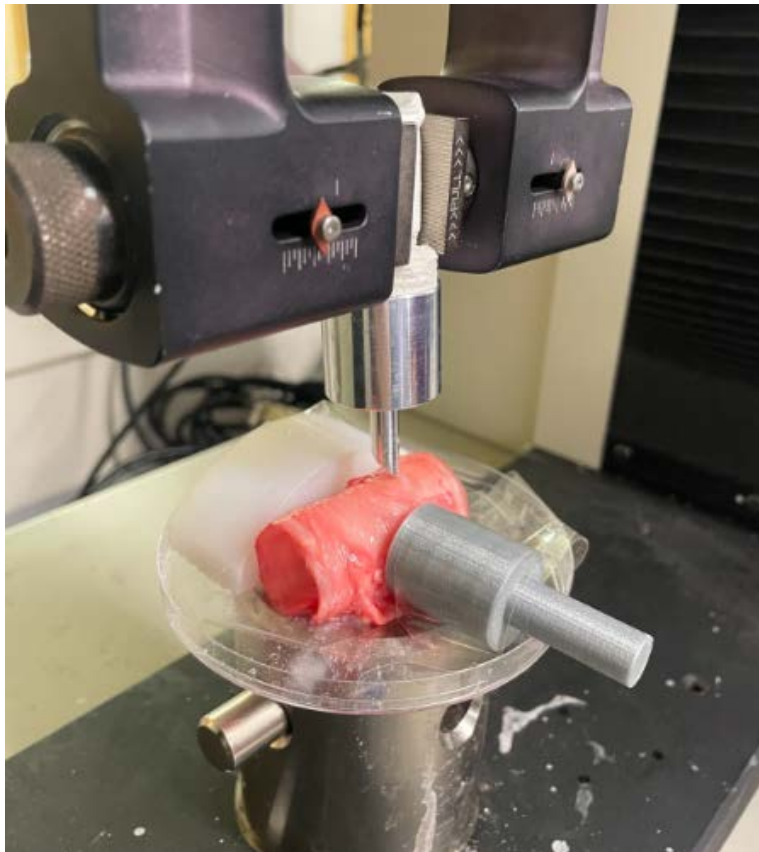

Larynx testing on the MTS machine:



**Conclusions/action items:**

The team did not get any viable data from the MTS machine. This could be due to the grips and the inability to secure the larynx and trachea. These are things that could easily be fixed next semester to improve results obtained.





## 2023/9/18 Emergency Airway Research

Zac Mayhew - Sep 28, 2023, 4:31 PM CDT

**Title:** Emergency Airway Research

**Date:** 9/18/23

**Content by:** Zac

**Present:** n/a

**Goals:** The goal of this research is to gain an understanding of the surgery we are trying to mimic. If I have a better understanding of the surgery then I can know what exactly we are trying to make.

**Content:**

Citation: J. Borke, "Emergency airway puncture - series - Normal anatomy: MedlinePlus Medical Encyclopedia," *MedlinePlus*, Oct. 06, 2022.

- Cricothyroid cartilage and thyroid form the narrowest section of the larynx
- The larynx is the tubular structure in your neck that air passes through to the lungs
- The area between the cricothyroid and thyroid is a frequent place for obstruction
- Cricothyrotomy is a procedure that is done in emergencies to relieve an airway obstruction
- In acute situations a needle is used below the thyroid cartilage
- More frequently, incisions are made over the cricothyroid membrane then another incision is made through the membrane

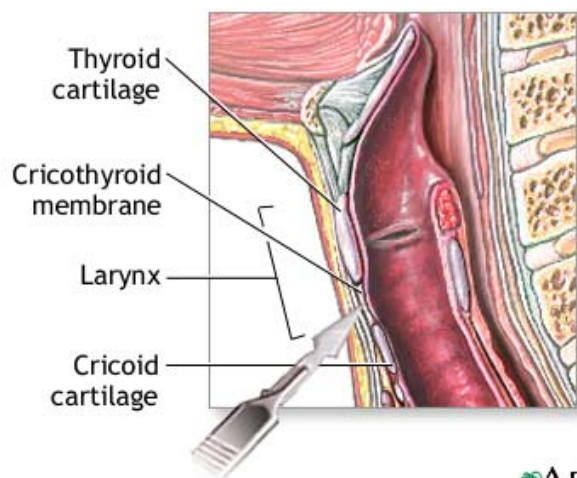

- A breathing tube is then inserted through the incision
- Procedures are followed by a tracheostomy if they need prolong use of a breathing tube

**Conclusions/action items:**

Now that I am aware of the basics of how an emergency airway is done, I can do deeper research into how we could improve it. I think that eliminating the use of two incisions and using the needle method is what we will be trying to do as a team.



## 2023/9/18 Choking Background Research

---

Zac Mayhew - Sep 28, 2023, 4:56 PM CDT

**Title:** Choking Background Research

**Date:** 9/17/2023

**Content by:** Zac

**Present:** n/a

**Goals:** The goal of this research is to gain a better understanding of the statistics associated with choking. This will allow me to have a better understanding of the scope of this project.

**Content:**

Citation: "Choking: First aid - Mayo Clinic." <https://www.mayoclinic.org/first-aid/first-aid-choking/basics/art-20056637> (accessed Sep. 20, 2023).

- Choking - object partially or completely obstructs the passage of air exchange between the upper airway and the trachea.
- **Occurs most frequently with people of either young (1-3) or old (60+) age.**
- In young people the obstruction is often a toy, coin, batter, or food.
- In the elderly it is almost always food
- **In 2015 5,051 people died from choking**
- Choking is the 4th leading cause of unintentional death
- Choking is the leading cause of infantile death
- Hot dogs are the most fatal food aspiration accounting for 17% of food-related fatalities.
- The most common presenting symptoms are the classical triad of a paroxysmal cough, wheezing, and dyspnea or decreased air entry/decreased breath sounds in adults.
- The Heimlich maneuver is used on anyone choking over the age of 1.
- For people under 1, 5 black blows followed by 5 chest compressions

**Conclusions/action items:**

Now that I have a better idea of the scope of this project I feel ready to dive in and start coming up with solutions. I'm also excited because the project, although small, could save someone's life one day.



## 2023/9/18 CPR research

---

Zac Mayhew - Sep 28, 2023, 5:15 PM CDT

**Title:** CPR Research

**Date:** 9/18/2023

**Content by:** Zac

**Present:** n/a

**Goals:** The goal of this research is to try and find some more statistics about choking, specifically CPR. I'm mostly looking for how long someone can go without oxygen before their brain starts to die.

**Content:**

Citation: J. Borke, "CPR - adult and child after onset of puberty: MedlinePlus Medical Encyclopedia," Jan. 02, 2023.  
<https://medlineplus.gov/ency/article/000013.htm> (accessed Sep. 19, 2023).

- **Permanent brain damage or death can occur within 4 min if a person's blood flow stops**
- Training is required to be able to do CPR procedures
- **Death can occur as soon as 4-6 min after oxygen has stopped being delivered to the brain**
- Use head tilt chin lift to open the airway
- The rest of the article is for doing CPR which isn't the purpose of this project

**Conclusions/action items:**

Since brain damage can occur so quickly after oxygen is cut off, it is clear that this project could save a lot of lives.



## 2023/9/20 Anatomy of Cricothyroid Membrane

Zac Mayhew - Sep 29, 2023, 12:10 PM CDT

**Title:** Anatomy of Cricothyroid Membrane

**Date:** 9/20/2023

**Content by:** Zac

**Present:** n/a

**Goals:** The goal of this research is to gain a better understanding of the anatomy of the cricothyroid membrane. In the process I hope that some ideas will come to mind of possible designs that could be used.

**Content:**

Citation: S. Develi, B. Yalcin, and F. Yazar, "Topographical anatomy of cricothyroid membrane and its relation with invasive airway access," *Clinical Anatomy*, vol. 29, no. 7, pp. 949–954, Oct. 2016, doi: 10.1002/ca.22750.

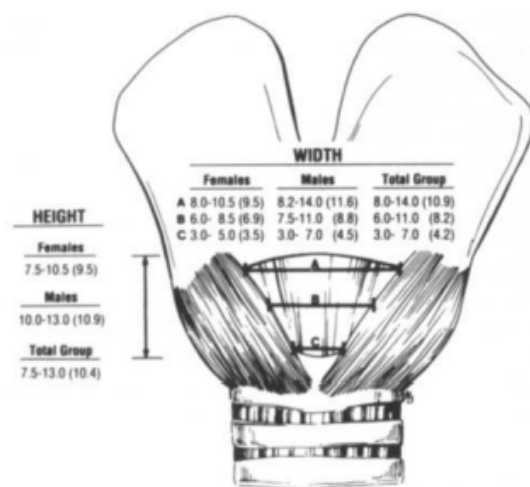

**Fig. 1.** Dimensions of cricothyroid membrane. Range and (mean) values reported in millimeters.

- 
- Complications of cricothyroidotomies include unsuccessful site of tube placement, damage to cricoid and thyroid cartilages, stoma1 or endobronchial hemorrhage, and subglottic stenosis
- Cricothyroid membrane average width is 8.2 mm and height of 10.4 mm
- Trachea isn't used for emergency airway because of how low it is and all the blood supply around it
- Cricothyroid is found using palpation
- The cricothyroid artery coursed across the upper onethird of the cricothyroid membrane in 13 specimens (93%), and across the lower portion of the membrane in one cadaver
- thyroid veins were found crossing the cricothyroid membrane.
- In 12 of the specimens (80%), small veins from the region of the thyroid isthmus traversed the cricothyroid membrane, followed the cricothyroid and superior thyroid arteries, and drained into the internal jugular vein
- A transverse stab incision of the membrane near its lower border adjacent to the cricoid cartilage is recommended to avoid injury to the cricothyroid artery

### Conclusions/action items:

After reading this, there is a lot to consider when making our product. It seems that there is a somewhat decent chance of hitting the artery when performing the cricothyroidotomy. This is definitely something we will want to consider when designing our product.



## 2023/10/1 EMS Response

---

Zac Mayhew - Oct 20, 2023, 9:04 AM CDT

**Title:** EMS Response Notes

**Date:** 10/1

**Content by:** Zac

**Present:** n/a

**Goals:** The goal of this research is to better understand the scope of our problem.

**Content:**

**Citation:** "Emergency Medical Services Response Times in Rural, Suburban, and Urban Areas - PMC." Accessed: Sep. 19, 2023. [Online]. Available: <https://www.ncbi.nlm.nih.gov/pmc/articles/PMC5831456/>

Mean response times by locations:

- Suburban - 7.7 min
- Urban - 7 min
- Rural - 14.5 min
- Overall - 7.9 min

Obviously the response times aren't always 7 min but that is an average.

This can go along with the research about lack of oxygen permanently affecting the brain after 4 min.

It is clear that there is a need for this product on the market since without EMS on scene there isn't much the general public could do.

This product would be especially helpful in rural settings where response times are double urban areas.

**Conclusions/action items:**

This is something we would definitely want to include in our report and presentation so people are aware that there is a definite need for this product.



## 2023/10/5 BVM adapter size

---

Zac Mayhew - Oct 20, 2023, 9:05 AM CDT

**Title:** BVM Adapter Size

**Date:** 10/5

**Content by:** Zac

**Present:** n/a

**Goals:** The goal of this research is to get the measurements for what size we will have to make our BVM attachment.

**Content:**

**Citation:** <https://www.emsstuff.com/virobac2-viral-bacterial-filter-for-bvm/>

There are two connectors that we could choose.

The bigger one would be 22 mm inside diameter and 25 mm outside diameter

The smaller one has a 15 mm inside diameter and 22 mm outside diameter

I'm not 100% sure which diameter we want to use but might have to change the one in the drawing based on this.

I think based on my EMT training that the 15/22 mm one is the same as the BVM so we could have it be 15 mm and fit inside or be 22 mm and go around the outside.

**Conclusions/action items:**

I'm going to use these measurements to update the SolidWorks designs so that our design is adaptable to a BVM.



## 2023/10/9 Cricothyroidotomy Indications/Contraindications

---

Zac Mayhew - Oct 20, 2023, 9:05 AM CDT

**Title:** Cricothyroidotomy Indications/Contraindications

**Date:** 10/20

**Content by:** Zac

**Present:** n/a

**Goals:** The goal of this research is to get an more in depth understanding of when cricothyroidotomies are used.

**Content:**

**Citation:** <https://emedicine.medscape.com/article/80241-overview>

Indicated:

- patients airway can't be secured by non surgical methods
- non-surgical devices (intubating laryngeal mask airway, fiberoptic scope, or lighted stylet) aren't available or failed.
- not a candidate for orotracheal or nasotracheal intubation with severe facial trauma.
- cricothyroidotomies are meant to be quick fixes and not used as a long-term airway.
- they will turn cricothyroidotomies into tracheostomies in a timely manner.
- in children (<12) needle cricothyroidotomy with percutaneous transtracheal ventilation is airway of choice.

Contraindications:

- <12 years old unless patient is adult sized
- obstruction inferior to where the cricothyroid membrane is.
- Presence of a SHORT neck (Surgery, Hematoma, Obesity, Radiation, Trauma/burns).
- Tumor, infection, or abscess at incision site
- Lack of operator expertise

**Conclusions/action items:**

This information is very helpful in understanding when an emergency cricothyroidotomy would be done in the field. These are maybe things we will want to consider when making changes to the design of our product.



## 2023/10/26 Locating Cricothyroid Membrane notes

Zac Mayhew - Oct 26, 2023, 12:27 PM CDT

**Title:** Locating Cricothyroid Membrane

**Date:** 10/26

**Content by:** Zac

**Present:** N/a

**Goals:** The goal of this research is to figure out how the cricothyroid membrane is located. This should be helpful for creating an instruction pamphlet that can be included in our kit.

**Content:**

- Anesthesiologists were more successful palpating upwards from the sternal notch compared to downward from the adam's apple.
- The bottom up approach was 84% successful compared to 56% success in the top down method
- The Cricothyroid membrane is easier to find in men compared to women because of the prevalence of landmarks
- For obese patients locating the cricothyroid membrane is much more difficult because of the excess neck fat.
- From pictures I saw online it is easier to locate if the patients neck is extended since the landmarks become more visible then.



**Conventional laryngeal handshake**



**Modified laryngeal handshake**

**Conclusions/action items:**

Knowing this information I have an idea of how we could create an instruction manual to use. I did try this on myself and the cricothyroid membrane is super small but pretty easy to palpate. I think it would be fun to go in the public and see if using our instructions people could correctly identify the cricothyroid membrane on me.





## 2023/9/27 Hand Stabber Design

Zac Mayhew - Sep 28, 2023, 2:39 PM CDT

**Title:** Hand Stabber Design

**Date:** 9/28/2023

**Content by:** Zac

**Present:** n/a

**Goals:** The goal of this design is to begin thinking about different ways that this project can be approached. This design is meant to be simple and reliable. Since it is simple it should have a low cost to fabricate.

**Content:**

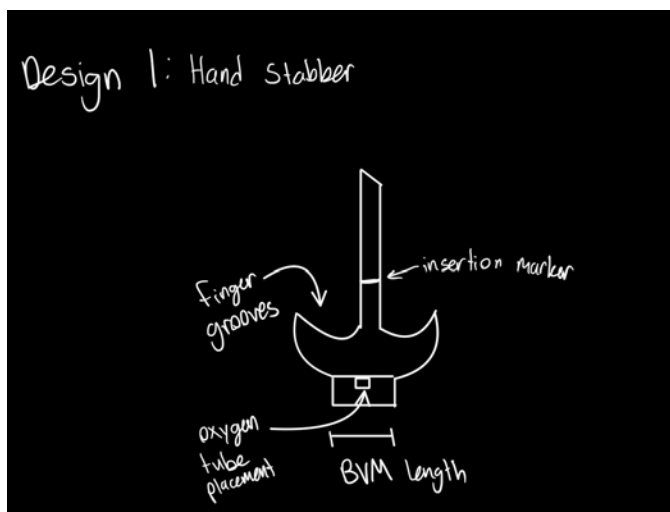

The Hand Stabber design includes a long sharp plastic tube that has a handle as well as a bag valve mask (BVM) and oxygen tube attachment at the end. The handle allows the user to comfortably and controllably hold the device while stabbing the patient's neck so they don't miss. The attachments at the end would allow the device to be used as the method of creating and maintaining the airway.

**Conclusions/action items:**

Share design with team and talk about what dimensions we would want the final device to be.



## 2023/9/27 Spring Loaded Design

Zac Mayhew - Sep 28, 2023, 2:43 PM CDT

**Title:** Spring Loaded Design

**Date:** 9/27/2023

**Content by:** Zac

**Present:** n/a

**Goals:** The goal of this design is to create a possible design for our design matrix. Since the first one I did was simple I want to be more creative with this one and use a different method of placing the tube.

**Content:**

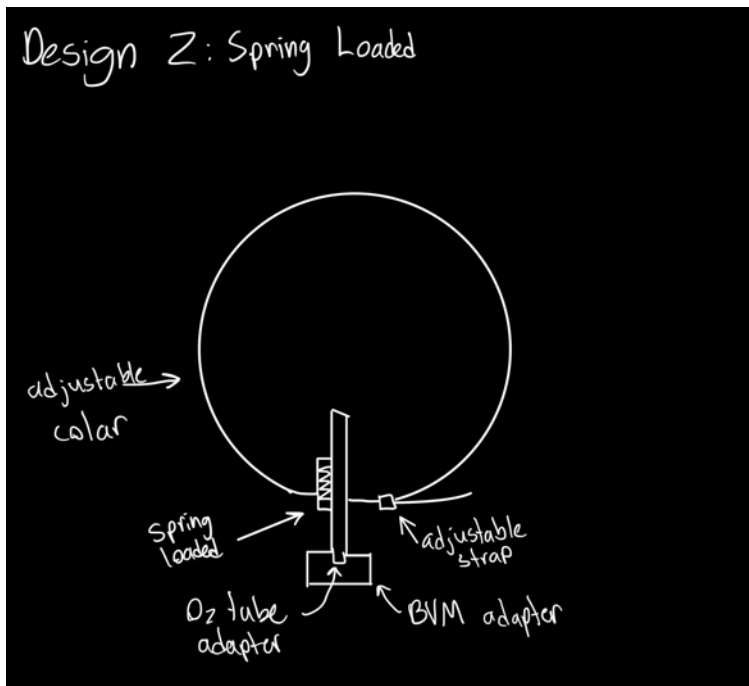

This design uses a similar piercing object as the Hand Stabber Design but instead of having finger grooves to hold onto the device, this device uses a spring to shoot the device into the patients neck. The collar would help hold the device in place while placing it and when it's in which would be helpful if you are transporting the patient in an ambulance. The device also includes the BVM and oxygen tube adapters to allow it to be used to create and maintain a patients' airway.

**Conclusions/action items:**

Bring the design to the team meeting and it could possibly be one of the designs we consider using for the design matrix. Also, if we do continue with it I would have to go back and find dimensions for each piece so it could work well.



## 2023/9/27 Hook Design

Zac Mayhew - Sep 28, 2023, 2:48 PM CDT

**Title:** Hook Design

**Date:** 9/27/2023

**Content by:** Zac

**Present:** n/a

**Goals:** The goal of this design is to come up with one more unique design to bring to the group meeting. I want three different designs so we have more options to pull form when discussing the design matrix.

**Content:**

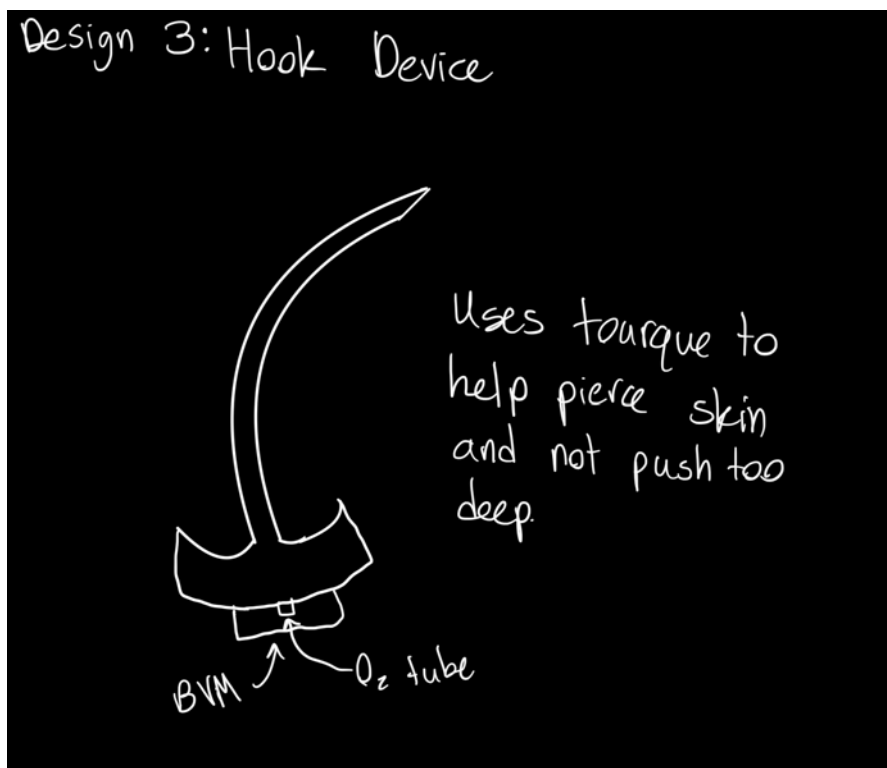

The hook device is similar to the Hand Stabber Design except the device would be curved instead of straight. My idea is that if the device is curved, you could use torque instead of having to stab the device into the patients neck. This would hopefully make it so you wouldn't make the hole too deep. It would also theoretically take less force and be easier to use.

**Conclusions/action items:**

Bring the design to team meeting and discuss it with the team. Will need to get dimensions if we chose to continue with the design.



# 2023/10/4 Hole Puncher SolidWorks V1

Zac Mayhew - Oct 20, 2023, 8:16 AM CDT

**Title:** Hole Puncher SolidWorks V1

**Date:** 10/4

**Content by:** Zac

**Present:** n/a

**Goals:** The goal of this document is to showcase the initial prototype made in SolidWorks for the Hole Puncher design.

**Content:**

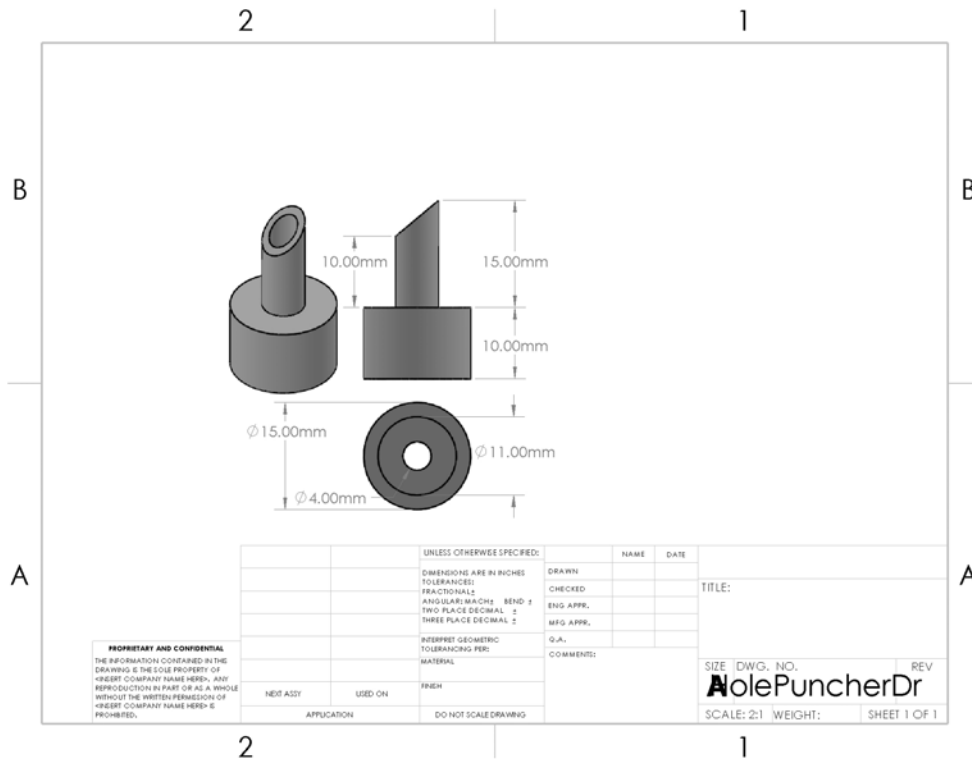

**Conclusions/action items:**

This design is our rough initial draft of the design. I'm sure we will make adjustments and the design will have some changes.

# 2023/10/5 Captain Hook SolidWorks

Zac Mayhew - Oct 20, 2023, 8:18 AM CDT

**Title:** Captain Hook SolidWorks

**Date:** 10/5

**Content by:** Zac

**Present:** n/a

**Goals:** The goal of this document is to showcase the SolidWorks draft of the Captain Hook design.

**Content:**

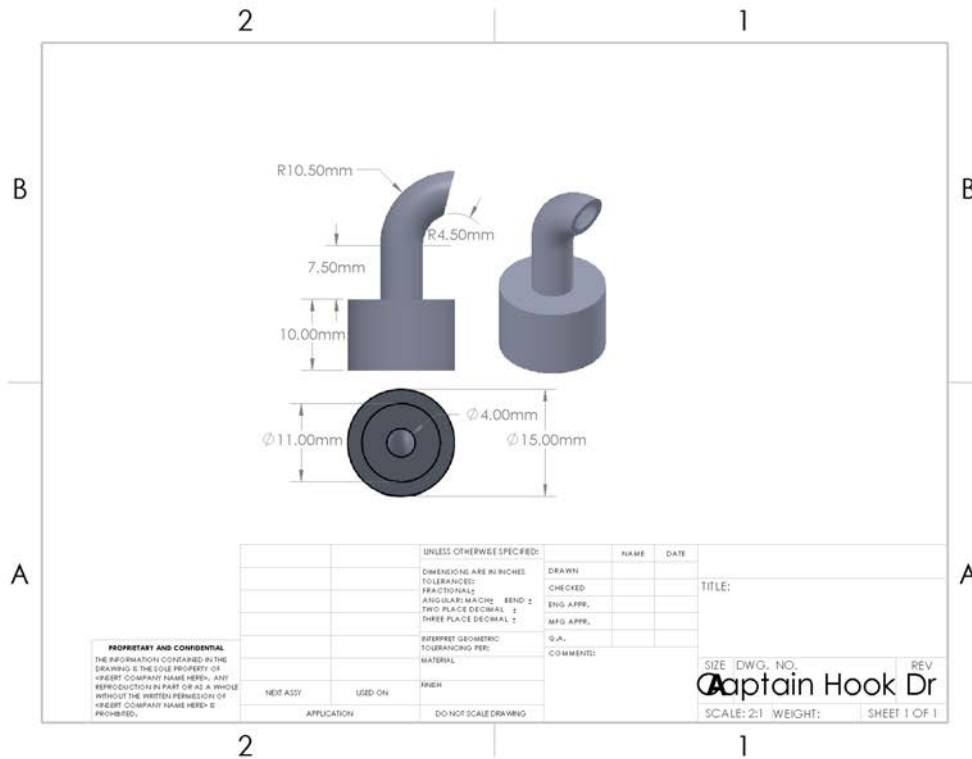

## Conclusions/action items:

We aren't planning on going with this design but based on how testing goes with the Hole Puncher we could come back and try this one to see if one is better than the other.



# 2023/10/15 Hole Puncher SolidWorks V2

Zac Mayhew - Oct 20, 2023, 8:15 AM CDT

**Title:** Updated Hole Puncher SolidWorks

**Date:** 10/20

**Content by:** Zac

**Present:** n/a

**Goals:** The goal of this update was to add an extra hole for increased airflow via clients request. We also extended the shaft to allow for experimenting with length.

**Content:**

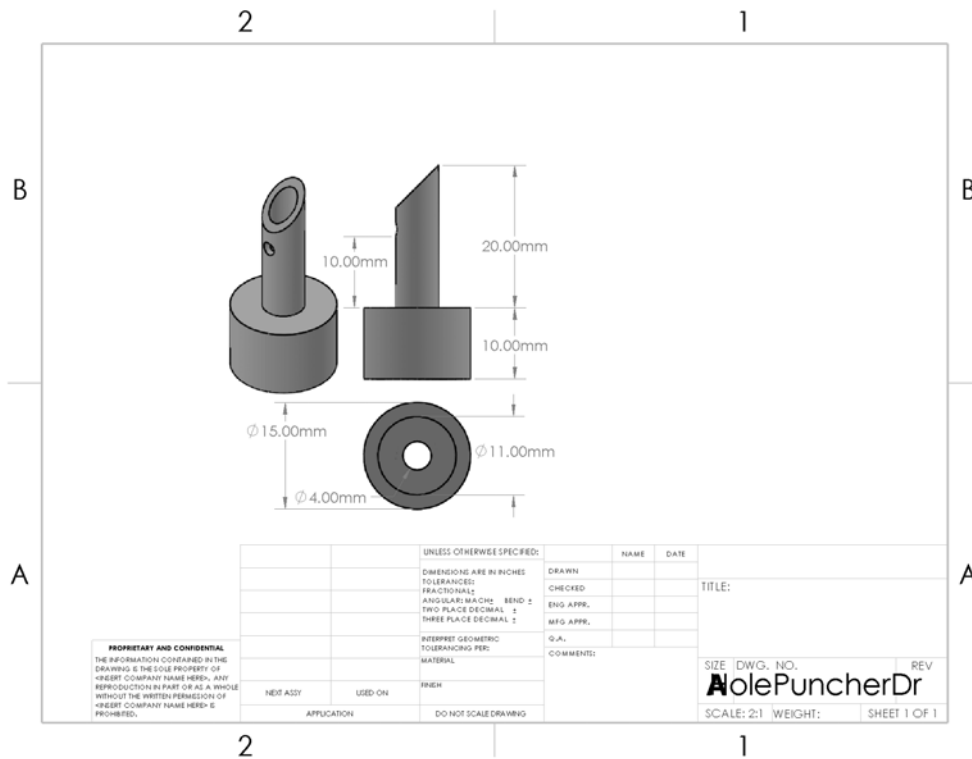

**Conclusions/action items:**

This will be printed as the initial prototype for our design. There will probably need to be some changes made after we do some basic testing with the device.



# 2023/10/26 Hole Puncher V3

---

**Title: Hole Puncher V3**

**Date:** 10/26/2023

**Content by:** Zac

**Present:** n/a

**Goals:** The goal of this update in the design is to make the needle the size it would be when used in the field. The internet said that 12-14 gauge needles were used so I went in the middle and made it the dimensions of a 13 gauge needle. I also added slits on either side of the BVM adapter that can be used to secure the device to the patient and as a way to insert the handle we plan on fabricating in the future.

**Content:**



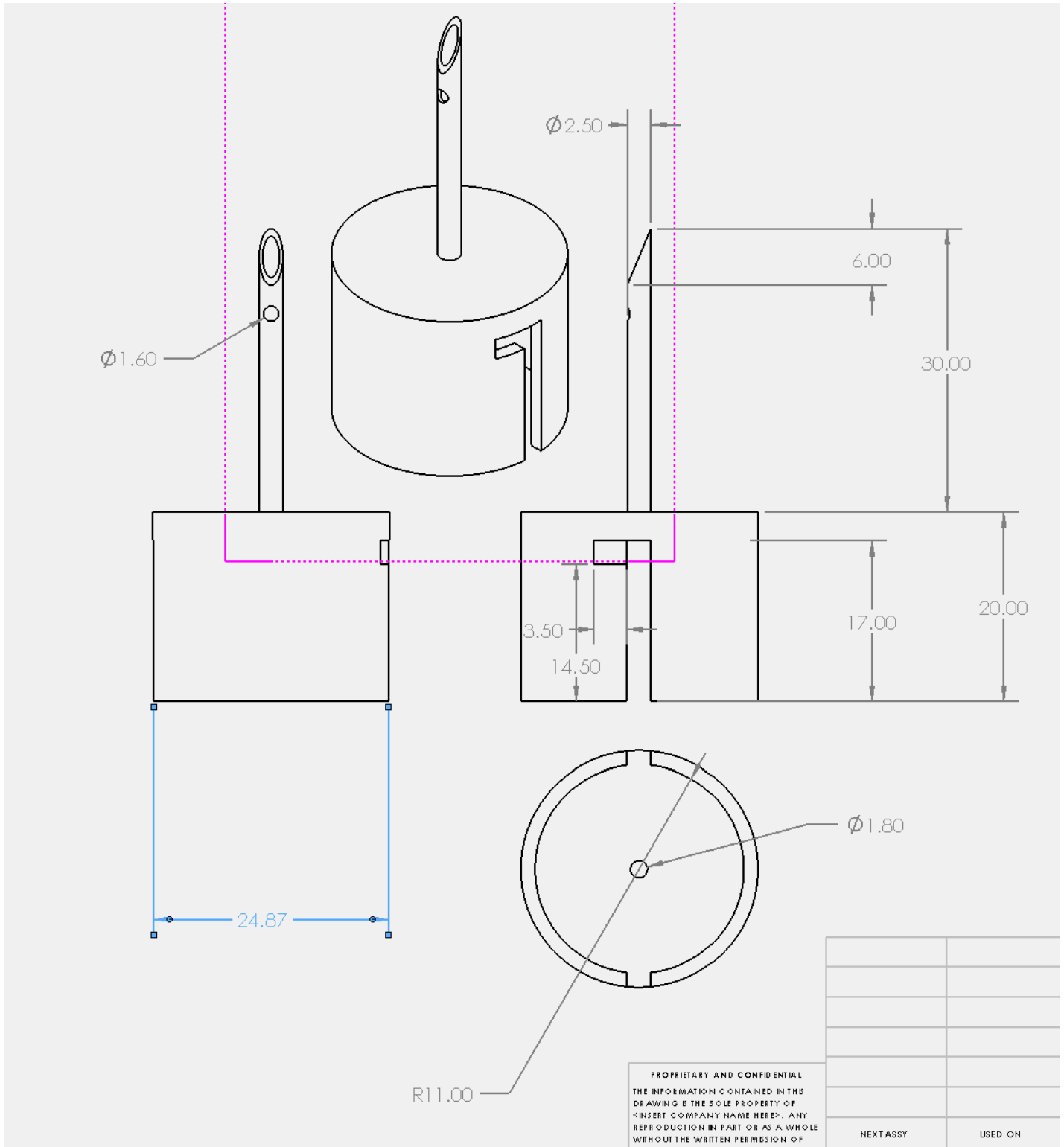

**Conclusions/action items:**

I will present my changes to the team to ensure they agree with the changes made. I think this is pretty close to what our final prototype will be so I'm excited to see what they think.



## 2014/11/03-Entry guidelines

---

John Puccinelli - Sep 05, 2016, 1:18 PM CDT

Use this as a guide for every entry

- Every text entry of your notebook should have the **bold titles** below.
- Every page/entry should be **named starting with the date** of the entry's first creation/activity. subsequent material from future dates can be added later.

You can create a copy of the blank template by first opening the desired folder, clicking on "New", selecting "Copy Existing Page...", and then select "2014/11/03-Template")

**Title:** Descriptive title (i.e. Client Meeting)

**Date:** 9/5/2016

**Content by:** The one person who wrote the content

**Present:** Names of those present if more than just you (not necessary for individual work)

**Goals:** Establish clear goals for all text entries (meetings, individual work, etc.).

**Content:**

Contains clear and organized notes (also includes any references used)

**Conclusions/action items:**

Recap only the most significant findings and/or action items resulting from the entry.



**Title:**

**Date:**

**Content by:**

**Present:**

**Goals:**

**Content:**

**Conclusions/action items:**