

## LOCK WASHER FOR DENTAL IMPLANT-SUPPORTED RESTORATIONS

---

PRELIMINARY REPORT

*BME 200/300*

Client: Dr. Donald Tipple

Advisor: Dr. John Puccinelli

Team Members:

Maggie McDevitt (Co-Team Leader)

Isabelle Peters (Co-Team Leader)

Aaron Marattil (Communicator)

Caroline Davis (BSAC)

Jacki Szelagowski (BWIG)

Kennedy Young (BPAG)

13 December 2023

**Abstract:**

Gum disease, tooth decay, injuries, or genetic conditions could all lead to a missing tooth. Dental implants are the preferred option to replace a single tooth or multiple teeth in different spots. This treatment option involves surgically implanting a post or frame into the jaw to replace the root, creating a permanent base for a replacement tooth. An abutment, which is cemented to the crown or fake tooth, is attached to the post via a screw. The most common issue with this method is that the screw loosens after a period of time; the abutment then must be removed and retightened by the dentist, which can be uncomfortable for the patient as the gums begin to move. The proposed solution is to add a lock washer on the screw to prevent the abutment from becoming loose, which currently is not used. A titanium alloy is the preferred material that will be used by a company to 3D print a split lock washer. It will be determined whether or not a lock washer is beneficial when combined with the current dental implant method. The amount of torque required to remove the screw from the post will be statistically analyzed and compared to the torque needed to remove it while it is attached to the lock washer.

## Table of Contents

<b>Abstract:</b>	<b>2</b>
<b>Table of Contents</b>	<b>3</b>
<b>Introduction and Background</b>	<b>4</b>
<b>Preliminary Designs</b>	<b>5</b>
<b>Preliminary Design Evaluation</b>	<b>7</b>
Proposed Final Design	9
<b>Fabrication/Development Process</b>	<b>10</b>
Materials	10
Methods	10
Testing	11
<b>Result</b>	<b>12</b>
<b>Discussion</b>	<b>12</b>
<b>Conclusions</b>	<b>13</b>
<b>References</b>	<b>14</b>
<b>Appendix A: Product Design Specifications</b>	<b>16</b>
<b>Appendix B: Material Expenses Sheet</b>	<b>25</b>
<b>Appendix C: Torque Testing Protocol</b>	<b>28</b>

## Introduction and Background

Dr. Donald Tipple has almost thirty years of experience with implants, and has noticed a few issues with the current design aside from the loosening of the screw. He dislikes how the screw is difficult to use in the mouth, as it is difficult to line up the screwdriver with the head of the screw.

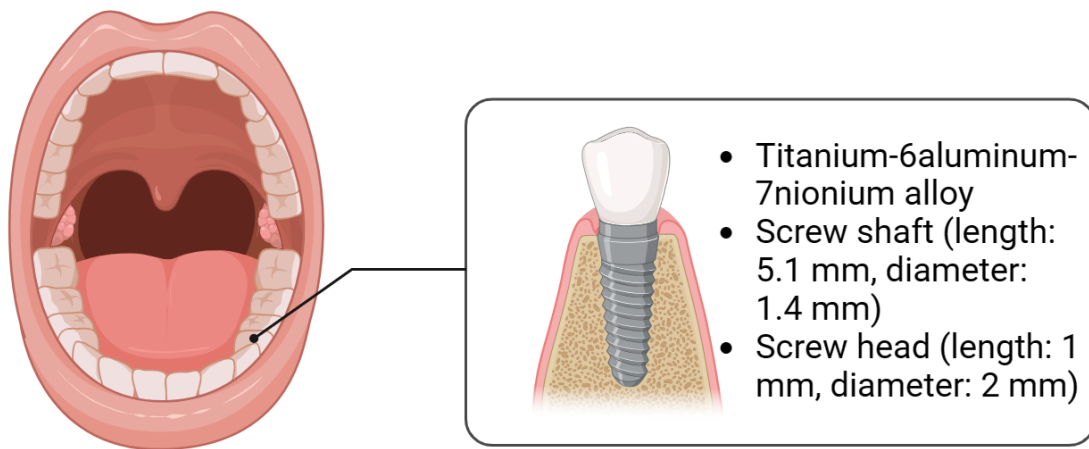
Studies have shown that around five percent of dental implants fail [1]. While this is not a large amount, replacing the abutment and crown can be tedious, require additional work for the dentist, and create an unideal situation for the patient. Dental implants can fail from occlusal forces from everyday use. The loosening of the implant can also cause discomfort for the patient, as it is possible for gums to grow between the part implanted into the jaw, and the screw that the crown is attached to. When the gum grows, it can become pinched between these two parts and cause discomfort for the patient.

A common dental implant design that is currently used is called the screwmentable. It features a small screw that screws into the implant with an abutment, which is what the crown is designed around [2]. While this piece has worked well, dentists still experience about one case per year in which the screw comes loose. In order to improve this, a system will be implemented to decrease the number of loosened screws, saving both the dentists and patients time. Competing designs that intend to prevent loosening involve a whole different implant system that does not work with our client's current design. The Straumann RidgeFit system utilizes a retention cap on top of the implant to hold the abutment in place instead of the abutment being screwed into the implant. This incorporates additional pieces such as posts, matrix housings, spacers, and collars which end up taking more time for dentists in the long run. A patented design uses a locking cap to prevent loosening [3]. While this does a good job of securing the screw in place, It requires an extra piece, and therefore is more work for the dentist implanting the crown.

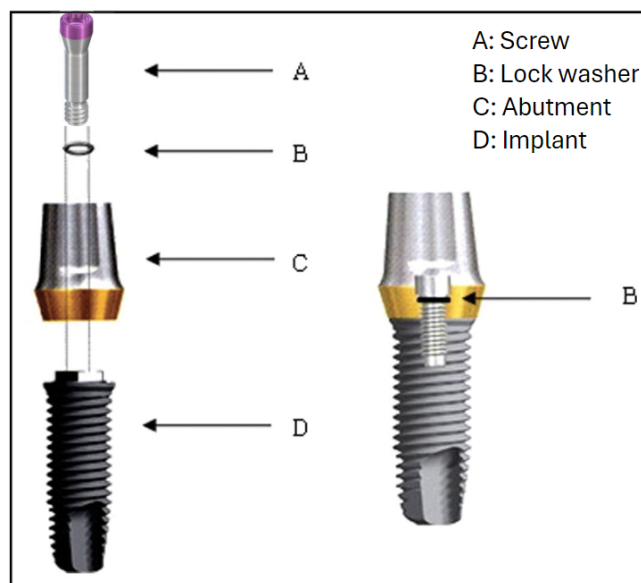
Surgical components					
					
<b>RidgeFit Implants</b> GH 2.8 mm: 042.947S, 10 mm 042.948S, 12 mm 042.949S, 14 mm GH 3.8 mm: 042.954S, 10 mm 042.955S, 12 mm GH 4.8 mm: 042.956S, 10 mm 042.957S, 12 mm	<b>Needle Drill, long</b> 027.0007S	<b>Pilot Drill</b> 027.0011S	<b>Adapter Optiloc® for Ratchet</b> 170.2	<b>Adapter Optiloc® for Handpiece</b> 170.1	<b>Paralleling Posts</b> 046.796

**Figure 1:** Competing Straumann Design Parts Including RidgeFit Implants [4]

It is essential that dental implants are made from a biocompatible material. Biocompatibility is an important factor to consider when designing a dental implant because it reduces the risk of implant rejection and allergic reactions, ensures a better chance of success and implant stability, and allows the implant to integrate into the bone more smoothly [4]. Because of this, the implants are commonly made from titanium, a titanium alloy, or zirconia. The goal is to design a solution that allows the screw to be securely in place for a minimum of 15 years. Further design specifications can be found in Product Design Specifications in Appendix A.

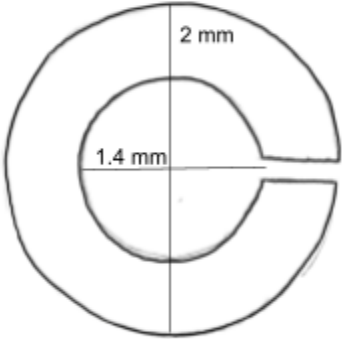
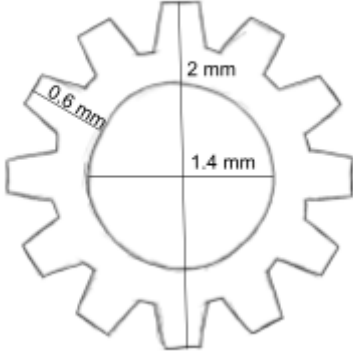
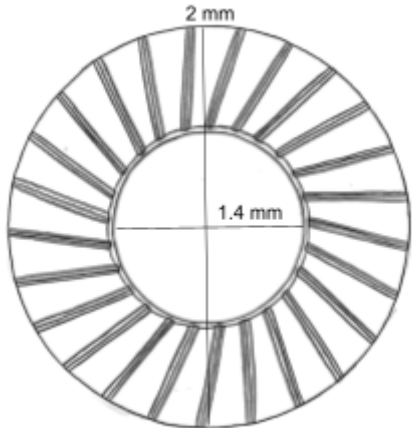
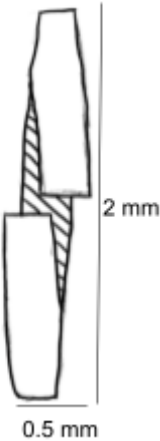
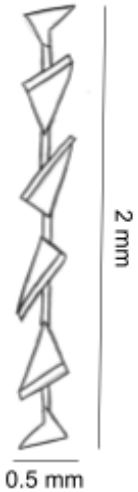
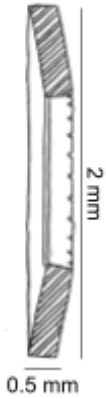


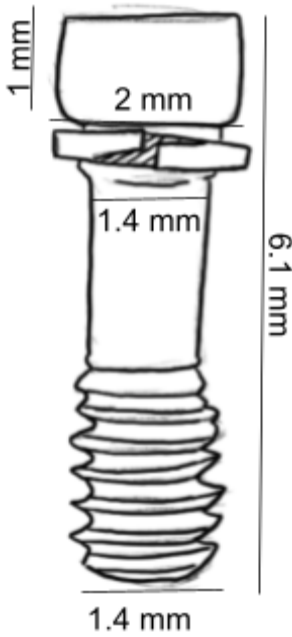
**Figure 2:** Implant Location and Screw Specifications



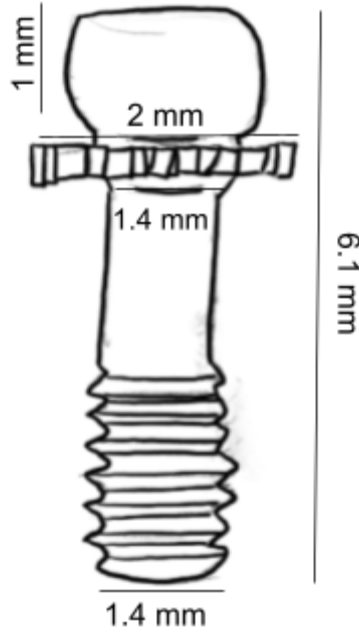
**Figure 3:** Fixture-abutment Complex with Washer [5]

## Preliminary Designs

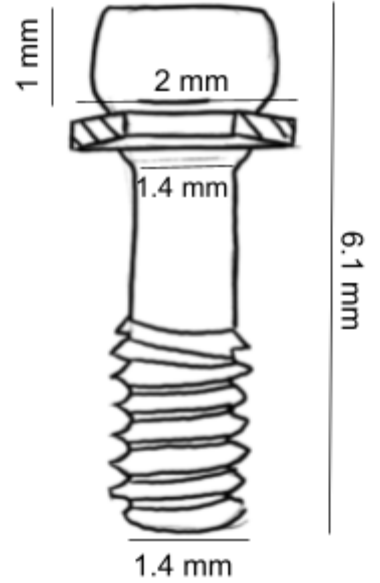
Split Lock Washer	External Tooth Lock Washer	Conical Washer
 <p style="text-align: center;"><i>Figure 4: Aerial profile of split lock washer</i></p>	 <p style="text-align: center;"><i>Figure 5: Aerial profile of external tooth lock washer</i></p>	 <p style="text-align: center;"><i>Figure 6: Aerial profile of conical washer</i></p>
 <p style="text-align: center;"><i>Figure 7: Side profile of split lock washer</i></p>	 <p style="text-align: center;"><i>Figure 8: Side profile of external tooth lock washer</i></p>	 <p style="text-align: center;"><i>Figure 9: Side profile of conical washer</i></p>



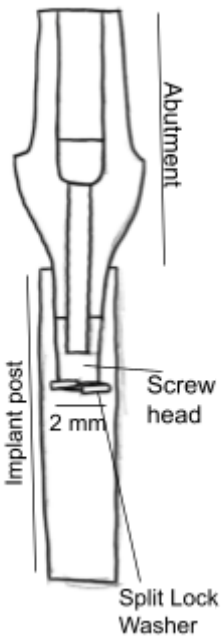
**Figure 10:** Split lock washer on the dental screw



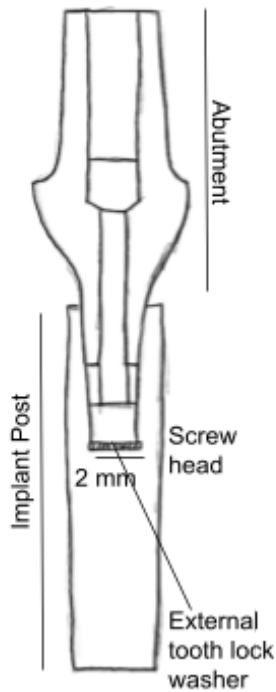
**Figure 11:** External tooth lock washer on the dental screw



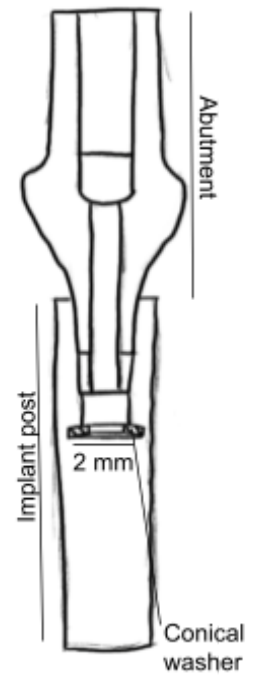
**Figure 12:** Conical washer on the dental screw



**Figure 13:** Split lock washer placement in dental implant



**Figure 14:** External tooth lock washer placement in dental implant



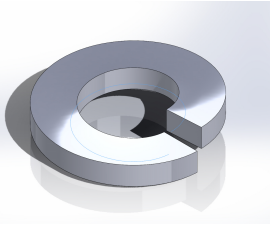

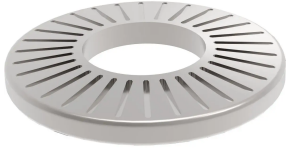
**Figure 15:** Conical washer placement in dental implant

	<i>washer placement in dental implant</i>	
This design is a split lock washer characterized by the split in the metal ring. The split creates an elevation, with one side of the washer being higher than the other. The unlevel surface creates compression when the screw is fastened. This compression pushes against the joint so the threads remain in place during vibrations, effectively preventing loosening.	This design is an external tooth lock washer. It is characterized by its outward-facing teeth, which are used to bite into the surface surrounding the screw. The external tooth lock washer has the best locking efficiency since the teeth are on the outside, providing more resistance to torsion. This design works best on large screws.	This design is a conical washer. It is characterized by its convex disc shape, which is supported by force from the exterior and center of the disc. As a result of the design, there is minimal movement during the compression process. Conical washers can maintain high tension, making them effective shock absorbers that keep assemblies tight.

## Preliminary Design Evaluation

It is crucial that the final product meets certain criteria to ensure optimal functionality and safety. The final material must be biocompatible and prevent adverse interactions between different types of metals within the existing mechanism. Finally, the torque to remove the screw must be greater than the 35 Newton-centimeters used to initially tighten the screw.

**Table 1: Design Matrix for Type of Washer**

Criteria (Weight)	Split Lock Washer		External Tooth Lock Washer		Conical Washer	
	 <p><b>Figure 16: Split Lock Washer</b></p>		 <p><b>Figure 17: External Tooth Lock Washer [6]</b></p>		 <p><b>Figure 18: Conical Washer [7]</b></p>	
Resistance to Torque (40)	4/5	32	3/5	24	3/5	24
Versatility (25)	5/5	25	1/5	5	4/5	20
Ease of Fabrication (20)	4/5	16	4/5	16	4/5	16



Safety (10)	4/5	8	3/5	6	4/5	8
Cost (5)	5/5	5	4/5	4	3/5	3
<b>Total (100)</b>	86		55		71	

The spring lock washer is highly resistant to torque as well as vibration and works well with small screws like what would be used in this project [8]. They are also the most versatile since their size can be easily scaled unlike other designs and, as previously stated, they work with small screws [9]. All the designs will likely be fabricated by a 3D printing company that uses titanium, making them equally difficult to fabricate. All the designs are quite safe, however, there was concern that the teeth on the external tooth lock washer could break off and cause problems, as well as a loss in production [10]. Additionally, the conical washer requires more material which would increase its cost. The split lock washer has none of these issues.

**Table 2: Design Matrix for Washer Material**

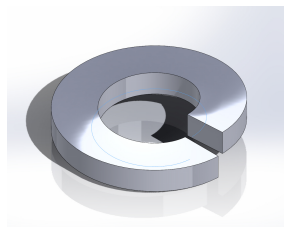
Criteria (Weight)	Pure Titanium		Titanium Alloy		Zirconia	
Strength (40)	3/5	24	5/5	40	4/5	32
Longevity/ Durability (25)	4/5	20	5/5	25	3/5	15
Biocompatibility (15)	5/5	15	5/5	15	4/5	12
Safety (10)	4/5	8	4/5	8	5/5	10
Aesthetics (5)	3/5	3	3/5	3	5/5	5
Cost (5)	5/5	5	4/5	4	3/5	3
<b>Total (100)</b>	75		95		77	

Titanium alloy is the strongest and lasts the longest [11], [12], [13], [14], [15]. All materials are quite biocompatible, however, titanium and titanium alloys osseointegrate much better [12]. While all materials are quite safe, zirconia is usually considered the safest as it limits adverse metal to metal interactions within the system [13]. Zirconia is the most aesthetic material, as zirconia implants are 100% white, hypoallergenic, and do not corrode [14]. It blends better with the gums and makes them almost invisible, creating a fully natural look. Pure titanium is the cheapest followed by a titanium alloy, and lastly, zirconia [18], [19], [20].

The material of the lock washer must be the same as the implant, as it can lead to adverse metal-metal interactions. Metal-metal interactions occur between metal ions in a compound. Within these compounds, the metal ions influence each other's behavior in a way that causes a distinction between the group of metal ions interacting and the sum of the metal ions. Metal-metal interactions can lead to adverse effects within the patient's body. These interactions can result in increased toxicity and affect the material's biocompatibility. Different metals being used within a device can result in corrosion or other reactions that can compromise the structural integrity of the device and release toxic compounds [20].

### **Proposed Final Design**

The proposed final design is a Split Lock Washer made of Titanium Alloy, the material chosen because of its strength and durability. The split lock washer was selected because of its resistance to torque and vibration. It was also the most versatile washer and could be scaled to any size. The final prototype should have an inner diameter between 1.45 and 1.55 mm, and an outer diameter between 3 and 3.4 mm.



*Figure 19: Proposed Final Design*

### **Fabrication/Development Process**

#### **Materials**

**Titanium Alloy:** An alloy that contains mostly titanium metal along with other chemical elements. In dentistry, beta titanium alloy is used most commonly. Other possible elements used in this alloy are zirconium, niobium, vanadium, iron, aluminum, and manganese. This beta alloy is used in dentistry primarily because of its strength and elasticity ratios being much higher than those of some sort of steel or other metal.

The current titanium alloy screw Dr. Tipple uses is called Titanium-6aluminum-7niobium alloy (TAN). It contains 6.50-7.50 % mass niobium, 5.50-6.50 % mass aluminum, less than 1.09 % mass of other residuals (Ta, Fe, O, C, N, H) and the rest of the mass in titanium.

#### **Methods**

In order to create a prototype of the split lock washer on the dental implant screw, a lock washer can be ordered in the future with the specific design dimensions and material from a company—

either Protolabs located in Minnesota or Sculpteo located in France– to 3D print it. Both companies are able to provide a quote after a STL file is uploaded. Due to multiple companies providing expensive quotes with washers priced at about \$60 each, the direction of the project was shifted. It would not be economical to test to failure with washers of this price, especially considering that they may not be manufactured as expected.

Instead, No. 0 and larger scaled versions of stainless steel washers and screws were purchased from the UW MakerSpace and McMaster Carr. However, the washer was unable to fit ideally how it should in the final design, as the 3.48 mm outer diameter was too large. Extensive trial and error revealed that the optimal washer size to fit within the implant falls between No. 0 and No. 00. With cheaper materials, multiple tests were able to be performed until failure. For testing in this mechanism, failure refers to applying a substantial amount of force to the split lock washer, so it is permanently deformed and does not return to its original shape. The initial testing was done on stainless steel, has a higher elasticity, but lower ultimate strength than titanium. Testing was done on solidworks to prove that titanium would be strong enough on the necessary scale and with the necessary 35 N-cm applied to return to its original shape. The cheaper titanium split lock washers would allow for additional testing to be done to prove that the titanium split lock washer would provide more strength in the mechanism.

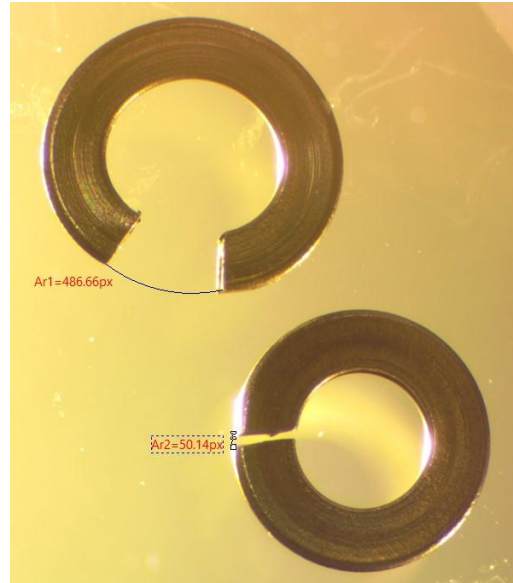
## Final Prototype

**Table 3: Various Perspectives of the Final Prototype**

<p><b>Figure 20:</b> Each individual component of the fixture-abutment complex with washer</p>	<p><b>Figure 21:</b> Final Design of the fixture-abutment complex with the washer</p>	<p><b>Figure 22:</b> Crown-Abutment complex with washer and screw</p>

## Testing

To test the placement of a split lock washer directly underneath the tapered screw head, the same screw that Dr. Tipple uses in practice was screwed directly into an implant in a mold of a patient's back teeth. A No. 0 stainless steel split lock washer with an inner diameter of 1.575 mm was used. Once removed, the arc deformation in the split was ten times greater than the initial arc length. Due to this result, it was concluded that placing the washer in this position would fail.



**Figure 23:** Deformed Split Lock Washer

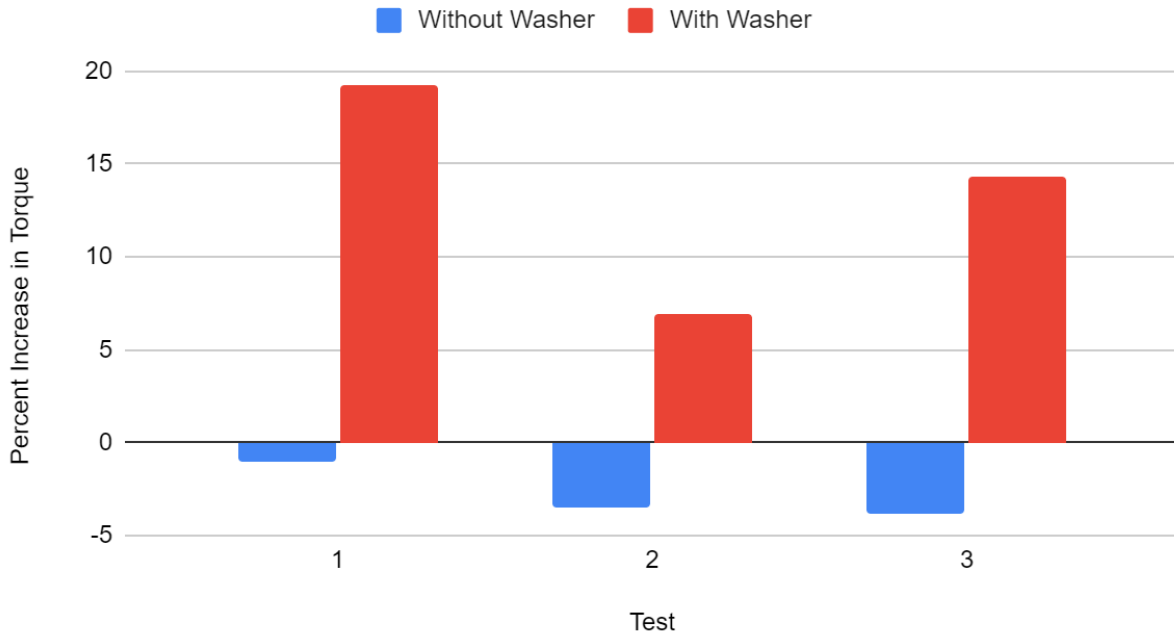
To test the implementation and efficacy of a split lock washer in a dental implant, a test was conducted on a larger scale. A screw, split lock washer, and flat washer, each 8.865x larger, were used to simulate the design and provide clear results. A control was first established by using a flat washer around the screw and tightening the screw in at around 200 Newton-centimeters, recording the exact torque used to tighten the screw. After five minutes has passed, the screw is unscrewed, and the torque required to remove the screw is recorded. This process is repeated a minimum of 3 times. The same experiment is then replicated with a split lock washer. The split lock washer is placed beneath the flat washer to simulate the split lock washer making contact with the abutment (the flat lock washer replacing the contact with the abutment) as opposed to the screw head. The screw is once again tightened at around 200 Newton-centimeters, and the precise torque is recorded. The screw sits for five minutes and then is removed. The torque required to remove is recorded and the process is repeated a minimum of 3 times, replacing the split lock washer for each new run. An additional trial was run in which the washer and screw sat for ten minutes, and the torque needed to remove the screw increased by 35.72%.



*Figure 24: Torbal FSB2 Torque Testing Device*

## Results

### Percent Increase in Torque With and Without a Washer



*Figure 25: Graph showing results from testing.*

The average percent change for the group without a split lock washer was -2.79%. The average percent change for the group with the split lock washer was 13.5%. Running a paired T-test returns a value of 5.4195. Additionally, this T-test returned a p-value of 0.0324 which is less than 0.05, showing that the means are significantly different from one another, and therefore the split lock washer provided a significant increase in torque.

## Discussion

While implementing a lock washer as part of the implantation procedure does not have many direct ethical considerations, metal dental implants being inserted into the gum as a tooth root is controversial to some dentists. It can be viewed as the cheap and easy way to solve a dental issue, as opposed to doing a bone graft [18]. However, there are also many people without dental insurance who cannot afford dental implants, and that needs to be taken into account as well. Ultimately, the patient's personal and religious values cannot be neglected when considering treatment options as patient autonomy is expected. The American Dental Association Principles of Ethics and Code of Professional Conduct also outlines that dental providers obligate moral commitment towards the welfare of their patients; each patient presents a slightly different case, and it must be individually treated as such [22].

An additional aspect that must be taken into consideration is whether the washer should be permanently or temporarily attached to the top of the abutment. Dr. Tipple brought up the possibility of the screw breaking within the patient's mouth, which could lead to the washer falling into their mouth if it is not properly secured. This raises a safety concern, and further work must be done to mitigate this risk. Using dental glue would suffice as a temporary solution.

Two hypotheses were proposed to explain the observed increase in torque required to remove the screw increased after it sat for ten minutes instead of five minutes. The first idea posed was that as the screw sat for an extended period, the washer was able to set, allowing the split washer to generate an increased amount of spring force. However, a more likely explanation suggests that the screw could have been screwed in too tightly in some of the previous trials, causing the washer to lose its locking efficacy and behave similarly to a flat washer [23].

## **Conclusions**

The primary objective of the project was to design an effective solution to mitigate the loosening of dental implants over time. Occlusal forces, such as chewing and grinding teeth can cause the dental implants to gradually loosen over a long period of time. While such instances are infrequent, addressing this issue is crucial as it poses challenges for dentists during abutment removal for re-tightening. Additionally, the loosening of the screw can cause discomfort for the patient as their gums can grow between the gap that is formed, and cause discomfort as their gums can be pinched. In order to combat this problem, a lock washer will be placed on the screw that engages the screw, and makes it less likely to loosen. The proposed design solution centers around both the client's current implant solution and the use of a split lock washer. It would preferably be made of a titanium alloy, as it offers torque resistance and biocompatibility, making it the best choice for enhancing the long-term stability of dental implants. Finally, in testing the placement of the washer both above and below the abutment, it was decided that it would provide resistance to torque and vibrational forces the best below the abutment as it will not deform around the head of the tapered screw. In essence, the aim of this project was to explore the potential of a washer, particularly a split lock washer, in reducing occurrences of implant screw loosening, offering both practical benefits for dentists and enhanced comfort for patients.



## References

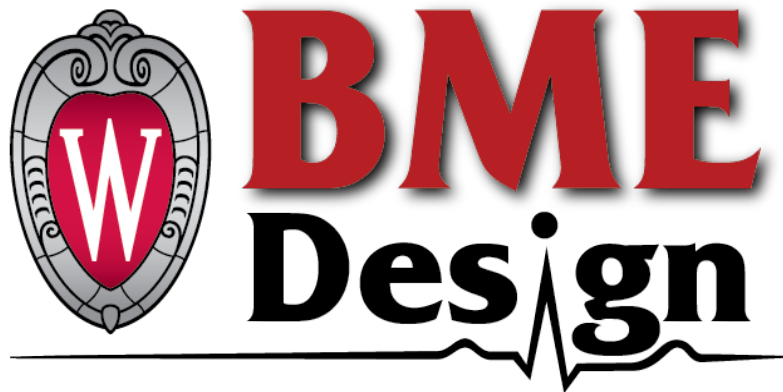
- [1] P. K. Moy, D. Medina, V. Shetty, and T. L. Aghaloo, “Dental implant failure rates and associated risk factors,” *Int. J. Oral Maxillofac. Implants*, vol. 20, no. 4, pp. 569–577, 2005.
- [2] “Screwmentable Implant Crowns,” *Decisions in Dentistry*. Accessed: Oct. 11, 2023. [Online]. Available: <https://decisionsindentistry.com/article/screwmentable-implant-crowns/>
- [3] D. Kennard, “Immediate provisional implant,” US8608473B2, Dec. 17, 2013 Accessed: Oct. 11, 2023. [Online]. Available: [https://patents.google.com/patent/US8608473B2/en?q=\(dental%2bimplant%2bscrew\)&oq=dental%2bimplant%2bscrew&page=4](https://patents.google.com/patent/US8608473B2/en?q=(dental%2bimplant%2bscrew)&oq=dental%2bimplant%2bscrew&page=4)
- [4] A. T. Sidambe, “Biocompatibility of Advanced Manufactured Titanium Implants—A Review,” *Materials*, vol. 7, no. 12, pp. 8168–8188, Dec. 2014, doi: 10.3390/ma7128168.
- [5] O. Jamiyandorj, S. Kim, J.-S. Shim, and K.-W. Lee, “Effect of Using a Titanium Washer on the Removal Torque of an Abutment Screw in the External Connection Type of Dental Implant,” *Implant Dent.*, vol. 21, no. 2, p. 156, Apr. 2012, doi: 10.1097/ID.0b013e31824a02b9.
- [6] “Hillman 3/8 in. Stainless Steel External Tooth Lock Washer (40-Pack) 43804 - The Home Depot.” Accessed: Sep. 28, 2023. [Online]. Available: <https://www.homedepot.com/p/Hillman-3-8-in-Stainless-Steel-External-Tooth-Lock-Washer-40-Pack-43804/204786104>
- [7] “M16 AFNOR Serrated Conical Washers (NFE 25511)- A2 Stainless Steel: Accu.co.uk: Washers & Spacers.” Accessed: Sep. 28, 2023. [Online]. Available: <https://www.accu.co.uk/afnor-serrated-conical-washers/391900-HAFS-M16-A2>
- [8] “Seastrom.” Accessed: Sep. 28, 2023. [Online]. Available: <https://www.seastrom-mfg.com/SeastromLogo.html>
- [9] “Spring Washer vs. Flat Washer: How to Choose Correctly | MISUMI Mech Lab Blog.” Accessed: Sep. 28, 2023. [Online]. Available: <https://us.misumi-ec.com/blog/spring-washer-vs-flat-washer-how-to-choose-correctly/>
- [10] “Belleville Disc Washer Springs - Learn About | Lee Spring.” Accessed: Sep. 28, 2023. [Online]. Available: <https://www.leepring.com/learn-about-belleville-washers>
- [11] “Titanium, Ti.” Accessed: Sep. 28, 2023. [Online]. Available: <https://www.matweb.com/search/DataSheet.aspx?MatGUID=66a15d609a3f4c829cb6ad08f0dafc01&ckck=1>
- [12] J. R. says, “Zirconium - Mechanical Properties And Material Applications,” AZoM.com. Accessed: Sep. 28, 2023. [Online]. Available: <https://www.azom.com/article.aspx?ArticleID=7645>
- [13] “Titanium. What Alloys Tooth Implants Are Made Of.” Accessed: Sep. 28, 2023. [Online]. Available: <https://uniqa.dental/articles/titanium-what-alloys-tooth-implants-are-made-of/>
- [14] “Information About Titanium,” Titanium Processing Center. Accessed: Sep. 28, 2023. [Online]. Available: <https://www.titaniumprocessingcenter.com/the-element-titanium/>
- [15] D. M. Nejad, “Zirconia Dental Implants Vs. Titanium Implants,” HELM | NEJAD | STANLEY. Accessed: Sep. 28, 2023. [Online]. Available: <https://www.beverlyhillsladentist.com/blog/are-zirconia-implants-better-than-titanium/>
- [16] “Titanium vs. Zirconia Dental Implants: What’s the Difference?,” Piney Point Dental Implant Center Blog. Accessed: Sep. 28, 2023. [Online]. Available:

<https://www.pineypointdentalimplants.com/blog/titanium-vs-zirconia-dental-implants-whats-the-difference/>

- [17] “Zirconia Dental Implants,” Dentist Prescott AZ. Accessed: Sep. 28, 2023. [Online]. Available: <https://prescottdentalarts.com/zirconia-dental-implants-prescott/>
- [18] J. Palmer, “What Is the Price of Titanium per Ounce? (2022 Guide).” Accessed: Sep. 28, 2023. [Online]. Available: <https://jewelsadvisor.com/what-is-the-price-of-titanium-per-ounce/>
- [19] “How Much Is Titanium Worth Per Pound In 2023? - Own Your Own Future.” Accessed: Sep. 28, 2023. [Online]. Available: <https://www.ownyourownfuture.com/how-much-is-titanium-worth-per-pound/>
- [20] D. H. M. D. D. Michael *et al.*, “Zirconia Dental Implants vs Titanium Implants - Which is the Best? Zirconia Implants Cost, Titanium Tooth Implant Cost,” Sarasota Dentistry. Accessed: Sep. 28, 2023. [Online]. Available: <https://www.sarasotadentistry.com/dental-blog/zircona-dental-implants-vs-titanium-implants/>
- [21] C. E. Misch, “A Current Dental Ethics Dilemma,” *Implant Dent.*, vol. 21, no. 3, p. 161, Jun. 2012, doi: 10.1097/ID.0b013e318258ec5d.
- [22] S. Gill, M. Prakash, M. Forghany, and R. M. Vaderhobli, “An ethical perspective to using bone grafts in dentistry,” *J. Am. Dent. Assoc.*, vol. 153, no. 1, pp. 88–91, Jan. 2022, doi: 10.1016/j.adaj.2021.09.011.
- [23] R. T. Barrett, “Fastener Design Manual.” Mar. 01, 1990. Accessed: Dec. 06, 2023. [Online]. Available: <https://ntrs.nasa.gov/citations/19900009424>
- [24] “Glossary of Dental Clinical Terms | American Dental Association.” Accessed: Oct. 10, 2023. [Online]. Available: <https://www.ada.org/publications/cdt/glossary-of-dental-clinical-terms>
- [25] “Screwmentable Implant Crowns,” Decisions in Dentistry. Accessed: Sep. 22, 2023. [Online]. Available: <https://decisionsindentistry.com/article/screwmentable-implant-crowns/>
- [26] “CFR - Code of Federal Regulations Title 21.” Accessed: Sep. 22, 2023. [Online]. Available: <https://www.accessdata.fda.gov/scripts/cdrh/cfdocs/cfcfr/cfrsearch.cfm?fr=872.3640>
- [27] “Straumann® Products and Solutions.” Accessed: Sep. 20, 2023. [Online]. Available: <https://www.straumann.com/en/dental-professionals/products-and-solutions.html>
- [28] “How Long Do Dental Implants Last, What Impacts the Duration?,” Healthline. Accessed: Sep. 21, 2023. [Online]. Available: <https://www.healthline.com/health/dental-and-oral-health/how-long-do-dental-implants-last>
- [29] W. Att *et al.*, “Time-dependent degradation of titanium osteoconductivity: An implication of biological aging of implant materials,” *Biomaterials*, vol. 30, no. 29, pp. 5352–5363, Oct. 2009, doi: 10.1016/j.biomaterials.2009.06.040.
- [30] “What’s the perfect dental office temperature?,” DANB. Accessed: Sep. 21, 2023. [Online]. Available: <https://www.danb.org/news-blog/detail/blog/finding-the-perfect-dental-office-temperature>
- [31] D. Flanagan, “Bite force and dental implant treatment: a short review,” *Med. Devices Auckl. NZ*, vol. 10, pp. 141–148, Jun. 2017, doi: 10.2147/MDER.S130314.
- [32] M. E. Hoque *et al.*, “Titanium and titanium alloys in dentistry: current trends, recent developments, and future prospects,” *Heliyon*, vol. 8, no. 11, p. e11300, Oct. 2022, doi: 10.1016/j.heliyon.2022.e11300.
- [33] “3D Printing Threads & Screws – Simple Guide,” All3DP. Accessed: Sep. 21, 2023.

- [Online]. Available:  
<https://all3dp.com/2/3d-printing-threads-and-screws-all-you-need-to-know/>
- [35] A. Modak, "Lock Washer vs Washer - What's the Difference," ThePipingMart Blog. Accessed: Sep. 21, 2023. [Online]. Available:  
<https://blog.thepipingmart.com/fasteners/lock-washer-vs-washer-whats-the-difference/>
- [36] E. F. Alsubaiy, "Abutment screw loosening in implants: A literature review," *J. Fam. Med. Prim. Care*, vol. 9, no. 11, pp. 5490–5494, Nov. 2020, doi: 10.4103/jfmpe.jfmpe\_1343\_20.
- [37] 14:00-17:00, "ISO/TR 18130:2016," ISO. Accessed: Sep. 22, 2023. [Online]. Available:  
<https://www.iso.org/standard/61530.html>
- [38] M. HILDMANN and S. Nagele, "Dental implant having a first conical screw part and a second cylindrical screw part," CA2831021C, Aug. 30, 2016 Accessed: Sep. 21, 2023. [Online]. Available:  
[https://patents.google.com/patent/CA2831021C/en?q=\(dental%2bimplant%2bscrew\)&oq=dental%2bimplant%2bscrew](https://patents.google.com/patent/CA2831021C/en?q=(dental%2bimplant%2bscrew)&oq=dental%2bimplant%2bscrew)
- [39] バーナード・ウエイズマン, "歯科用インプラント用の係止用キャップ," JP5149792B2, Feb. 20, 2013 Accessed: Sep. 21, 2023. [Online]. Available:  
[https://patents.google.com/patent/JP5149792B2/en?q=\(dental%2bimplant%2bscrew\)&oq=dental%2bimplant%2bscrew](https://patents.google.com/patent/JP5149792B2/en?q=(dental%2bimplant%2bscrew)&oq=dental%2bimplant%2bscrew)
- [40] D. Kennard, "Immediate provisional implant," US8608473B2, Dec. 17, 2013 Accessed: Sep. 21, 2023. [Online]. Available:  
[https://patents.google.com/patent/US8608473B2/en?q=\(dental%2bimplant%2bscrew\)&oq=dental%2bimplant%2bscrew&page=4](https://patents.google.com/patent/US8608473B2/en?q=(dental%2bimplant%2bscrew)&oq=dental%2bimplant%2bscrew&page=4)
- [41] M. A. M. NAVARRO, "System for securing a dental prosthesis," EP3017785A1, May 11, 2016 Accessed: Sep. 21, 2023. [Online]. Available:  
[https://patents.google.com/patent/EP3017785A1/en?q=\(dental%2bimplant%2bscrew\)&oq=dental%2bimplant%2bscrew&page=4](https://patents.google.com/patent/EP3017785A1/en?q=(dental%2bimplant%2bscrew)&oq=dental%2bimplant%2bscrew&page=4)

## Appendix A: Product Design Specifications



### LOCK WASHER FOR DENTAL IMPLANT-SUPPORTED RESTORATIONS

---

PRELIMINARY PRODUCT DESIGN SPECIFICATIONS

*BME 200/300*

Client: Dr. Donald Tipple  
Advisor: Dr. John Puccinelli

Team Members:

Maggie McDevitt (Co-Team Leader)  
Isabelle Peters (Co-Team Leader)  
Aaron Marattil (Communicator)  
Caroline Davis (BSAC)  
Jacki Szelagowski (BWIG)  
Kennedy Young (BPAG)

**Function:**

Dr. Tipple and many dentists worldwide use the dental implant placement technique called the screwmentable. This technique allows the abutment, or fixture that is placed between the implant post and the crown, to be screwed directly into the implant through a passageway in the crown [24]. This allows Dr. Tipple to adjust the crown as needed checking lateral, left and right occlusions and clench tests before the passageway is filled and sealed. The screw holding the abutment to the implant can become loose through everyday occlusal forces such as chewing. As the screw is installed a 35 Newton-centimeters torque is applied to keep it in place. The lock washer would be placed on the screw threads before it is inserted into the implant to apply spring tension to maintain this torque and keep the screw from loosening [25].

**Client requirements:**

- Lock washer must be fixed onto the screw.
- Lock washer design must work with the current Straumann screw that Dr. Tipple uses in practice.
- Titanium is the ideal material.

**Design requirements:****1. Physical and Operational Characteristics***a. Performance requirements:*

1. The device will be in constant use for up to fifteen years once implanted in the mouth.
2. The washer and screw must constantly maintain tightness in the implant.
3. There will be a constant normal force on all sides of the screw from the antagonist tooth and the implant. There will also be shear forces on the threads of the screw from the implant.

b. *Safety:*

1. The material must ensure biocompatibility; typically either a titanium alloy or zirconia is used.
2. The FDA sets regulations for dental implants and implant accessories. These regulations largely enumerate different tests the implant must be able to withstand to be safe and effective when in use. Examples include, the ability to withstand compressive and shear loads, biocompatibility, appropriate corrosion rate, compatibility in an MR environment, and more [26].

c. *Life in Service:*

1. On average, dental implants last 10-15 years within the mouth [27]. The lock washer should withstand continuous oral use without deterioration and prevent the screw from loosening for at least ten years [28].

d. *Shelf Life:*

1. Titanium, the most common metal used in dental restoration, has a shelf life of 10-25 years [29]. The durability of the titanium depends on storage and care.

e. *Operating Environment:*

1. Dental Screws are typically stored in small containers without specific protection measures. As a result, the lock washer will need to withstand corrosion and rusting under humidity levels between 20 and 60% and in temperatures between 20°C and 37°C as it will be in the mouth and stored at room temperature [30].
2. The lock washer must withstand a range of factors from exposure to the mouth. These factors include food substances, bacteria, saliva, blood, vibrations from speaking, and contact with teeth. In terms of pressure, the lock washer must be able to withstand forces of 50-800 N from the force exerted by the human jaw [31].

f. *Ergonomics:*

1. The screw and lock washer should be easy to handle. The dentist should be able to easily identify when the driver has been securely locked into the screw, making the installation process more manageable. The driver should be less than 4 mm wider than the screw and should match the insertion shape of the screw[7].
2. The screw should have a torque of 35 Newton-centimeters to fit securely in the abutment.

g. *Size:*

1. The dentist uses a narrower screw with a 1.4 mm shaft diameter. The whole screw is 6.1 mm long, and the screwhead makes up 1 mm of that length. The screwhead is slightly wider than the shaft with a 2 mm diameter.
2. The lock washer should have an inner diameter marginally smaller than the threads on the screw so that it is not able to slip off. The exact diameter would have to be determined through testing. Likely, the washer will be placed on the screw before creating the threads.

h. *Weight:*

1. The weight will ultimately depend on the selected materials used in different prototypes, and will likely remain under half a gram due to the size.

i. *Materials:*

1. Titanium has proven to work more effectively than alloys of titanium in preventing screw loosening, but zirconia is often used as well [5]. Titanium has many dental applications due to its biocompatibility, osseointegration, and corrosion resistance [32].
2. The final product should be made of a metal, but prototypes will likely be made of materials that can be used in 3D printing, such as nylon or ABS as they tend to

be stronger [33].

j. *Aesthetics, Appearance, and Finish:*

1. Washers with a rougher surface texture exhibit better performance when it comes to preventing screw loosening [5]. For our use within the dental implant system a roughness of Sa from 1-2  $\mu\text{m}$  would be suitably rough [34].
2. Unlike a normal washer, a split lock washer breaks in the middle of the circular shape, creating friction between the two parts and preventing loosening over time due to vibration [35].
3. The final prototype's finish will be metallic, and potentially gold coated (screw and washer) as that leads to better stability [36].

## 2. Production Characteristics

a. *Quantity:*

1. The client requires a single final prototype, however, the design should be able to be mass produced.

b. *Target Product Cost:*

1. The client did not outline a specific budget, but he is willing to spend \$200-\$300 to produce several prototypes and a lock washer made of a reliable material. Due to the size of the final design, it is anticipated that a fraction of the available budget will be spent.
2. A single titanium lock washer that has an inside diameter of 1.45 mm would cost around \$60 if 3D printed.

## 3. Miscellaneous

a. *Standards and Specifications:*

1. Standards
  - a. Standards for dental screws fall under the 11.060.15 Dental Implants



category by the International Organization for Standardization (ISO) [37].

- b. ISO/TR 18130:2016 Dentistry - Screw loosening test using cyclic torsional loading for implant abutment connection of endosseous dental implants [37].
  - i. This test is most appropriate for evaluating new types of joints held by screws. The report provides a protocol for cyclic torque on an implant abutment joint, and is intended for prefabricated implant bodies, implant abutments and implant connecting parts that are made of metallic materials [37].

## 2. FDA

- a. Dental implants, screws and abutments fall under FDA Class II regulation [26].
  - i. Code of Federal Regulations citation: 21CFR872.3640 [26].
  - ii. Must meet the Class II special controls requirements.

### b. *Customer:*

1. Dr. Donald Tipple has had many years of experience with implants. He has noticed a few issues with the current design aside from the loosening of the screw. He does not like how the current design of the screw is difficult to use in the mouth. This is because it is difficult to line up the screwdriver with the head of the screw. Although the project focuses mainly on avoiding the loosening of screws, creating small adjustments that allow more ease of implantation would be ideal to optimize our design.
2. The customer likes the current material, which is typically titanium or a titanium alloy.

### c. *Patient-related concerns:*

1. It is important when using this device to be careful with the implantation, as poor

technique can negatively affect the longevity of the device. The device also must be designed in a way that allows for a crown that is custom for the patient.

2. Lastly, it is important to take into consideration the discomfort that can be caused by the device. The client discussed how sometimes there can be discomfort when the screw loosens if the gums begin to grow over the implant.

d. *Competition:*

1. There are no current existing designs that include a lock washer on the screw. Some popular designs used in practice today are as follows.
  - a. Currently there is a patented design where the screw has both a conical and cylindrical screw part. The two different shaped portions of the screw allow it to stay more locked in place [38]. This is a commonly used design in dentistry, as it works pretty well, however the screw does still become loose from occlusal forces.
  - b. There is another patented design with a locking cap on the implant [39]. This design prevents loosening, however it requires the use of an additional piece which is not as desirable.
  - c. Another similar design has implant anchors to prevent the screw from loosening [40]. Like the one previously discussed, it requires an additional part, and it also does not fix the screw specifically, which is requested by the client.
  - d. One last design is a system for securing a dental implant that prevents it from coming loose [41]. This design also does not solely focus on the screw. It requires a lot of additional parts aside from the screw.
2. As outlined above, there is not a current design that attempts to solve this problem by focusing solely on the screw. Additionally, there is no design that utilizes a lock washer, which would not require additional steps for the dentist implanting the device.

## Appendix B: Material Expenses Sheet

Item	Description	Manufacturer	Part Number	Date	QTY	Cost Each	Total	Link
LabArchives Notebook	For Documentation purposes	LabArchives	N/A	9/8/23	1	\$15	\$15	<a href="#"><u>BME Design-Fall 2023 - Maggie MCDEVITT - LabArchives, Your Electronic Lab Notebook</u></a>
Steel Split Lock Washer	One with an inner diameter of 2.8 mm, and the other with a much larger diameter for presentation purposes	N/A - purchased from Makerspace	N/A	10/5/23	2	\$0.10	\$0.20	N/A
3D Printed PLA Split Lock Washer	Inner diameter of 5 mm, made of plastic and on a small support	Makerspace 3D printer	N/A	10/5/23	1	Free	Free	N/A
Split Lock Washers	18-8 Stainless Steel Split Lock Washer	McMaster-Carr	92146A510	11/13/23	1 pack of 100	\$4.02	\$4.02	<a href="#"><u>18-8 Stainless Steel Split</u></a>

	for Number 0 Screw Size, 0.062"							<u>Lock Washer for Numbe r 0 Screw Size, 0.062" ID, 0.137" OD   McMas ter-Carr</u>
Lock Washers	Internal-/Exte rnal-Tooth Lock Washers, 410 Stainless Steel, for Number 10 Screw Size	McMaster-Car r	90588A1 14	11/13/ 23	1 pac k of 100	\$7.64	\$7.64	<u>Internal -/Exter nal-Too th Lock Washer s, 410 Stainles s Steel, for Numbe r 10 Screw Size   McMas ter-Carr</u>
Screws	Same-Size Thread 18-8 Stainless Steel Shoulder Screw, 3/16" Shoulder Diameter, 1/4" Shoulder Length,	McMaster-Car r	91273A1 39	11/13/ 23	5	\$3.93	\$19.6 5	<u>Same-S ize Thread 18-8 Stainles s Steel Should er Screw, 3/16"</u>

	10-32 Thread Size	
--	----------------------	--

				<u>Should</u> <u>er</u> <u>Diamet</u> <u>er, 1/4"</u> <u>Should</u> <u>er</u> <u>Length,</u> <u>10-32</u> <u>Thread</u> <u>Size  </u> <u>McMas</u> <u>ter-Carr</u>
--	--	--	--	---

## **Appendix C: Torque Testing Protocol**

1. First, create a few taps in a thick piece of plastic about one and a half inches thick using a 10-32 tap and drill bit. Make sure to remove any jewelry, put long hair up, and wear safety goggles before using a drill press. Using a drill press, make sure that the drill bit makes a straight 90 degree angle with the material. Slowly lower it down until it makes contact with the material. Slowly push the drill bit into the material, back out after a couple pieces of material get caught in the bit, and repeat, but push the bit slightly further this time. Using a tap, create threads by using a tap and turning it 3 half-turns to the right followed by a half-turn to the left, and repeating until the rest of the hole is threaded.
2. Screw in a No. 10 internal hex screw with a No. 10 flat normal washer underneath the head of the screw. Using the Torbal FSB2 torque testing device with the handles attached, continue twisting in the screw with the bit attached to the torque testing device until the torque reaches around 200 Newton-centimeters. Make sure a timer is set so that the maximum torque is recorded every 10 seconds. Record the value, and let the screw sit for five minutes so that the washer is able to set. Firmly twist the handles of the torque tester to the left to record the amount of torque necessary to remove the screw. Record the absolute value of the minimum value and completely remove the screw. Repeat two more times.
3. Screw in a no. 10 internal hex screw with a No. 10 flat normal washer directly underneath the head of the screw and a split lock washer beneath the flat washer. Use the torque testing device again to measure the torque required to screw in (~200 Newton-centimeters) and remove the screw, and wait five minutes similarly to in step 2. Repeat two more times.