

Assistive Device for Wheelchair Users to Pull Pants all the Way Up

Preliminary Report

BME 300/200

Team Members:

Jacob Parsons, Co-Leader

Sallie Schoen, Co-Leader

Avery Schuda, Communicator

Ella Eklund, BSAC

Rayona Kinny, BWIG

Kate Murray, BPAG

Client:

Mr. Dan Dorszynski

Advisor:

Dr. Randolph Ashton

October 11th, 2023

Abstract

Individuals who are in wheelchairs overcome the challenge of putting on pants every day. Current product alternatives to leaning back and forth while pulling the pants up require upper body strength, which individuals with various forms of muscular dystrophy lack. The client of this project, Dan Dorszynski, has Becker's MD. The biggest hurdle to overcome when pulling up one's pants while in a wheelchair is separating one's bottom with the surface of the chair. The preliminary design will assist in supporting the user's body weight and allow them to be removed from the chair, while their pants are pulled up via a push of a button. The design will include a supportive device that will be oriented in front of the wheelchair for the user to lean on. The user's pants will be attached to a pair of suspenders that are connected to a RC winch that will pull the pants up when the user pushes a button. The desired outcome of this design is to rapidly decrease the amount of time it takes the client, and eventually other individuals with various forms of muscular dystrophy, to pull up their pants.

Table of Contents

Abstract	2
Table of Contents	3
I. Introduction	4
A. Impact and Motivation	4
B. Existing Designs/Treatments	5
C. Problem Statement	6
II. Background	7
A. Physiology and Biology	7
B. Design Specifications	8
C. Client Information	8
III. Preliminary Designs	10
A. Lean & Lift	10
B. Snap/Zip Pants	11
C. Suspenders	12
IV. Preliminary Design Evaluation	13
A. Design Matrix	13
B. Proposed Final Design	17
V. Fabrication/Development Process	17
A. Materials	17
B. Methods	18
VI. Testing	19
VII. Results	21
VIII. Discussion	22
IX. Conclusions	23
X. References	24
XI. Appendix	25
A. Product Design Specifications	25
B. Materials and Costs	32

I. Introduction

A. Impact and Motivation

The World Health Organization reports that 1% of the world's population or just over 65 million people need a wheelchair [1]. Almost every single person in a wheelchair has to put pants on every single day, and when leg mobility is limited, this simple task can become a daunting challenge for wheelchair users. The task can seem even more daunting when arm strength is also limited. People with muscular dystrophy, including Becker's MD or Duchenne MD have a recessive disorder that leads to progressive muscular degeneration and proximal muscle weakness [2]. This muscle weakness can occur in the arms or legs or throughout the body which leads to a larger challenge of pulling up pants.

The device is necessary because it helps people incapable of putting on their pants by themselves gain independence that they otherwise would not have on their own. Putting on pants is a part of everyone's daily routine and when it can not be completed or is incredibly difficult to complete, it can disrupt one's ability to start their day. With the device, users will be able to start the day much more efficiently and seamlessly.

The demographics of the device are anyone in a wheelchair and anyone with limited arm strength who is not able to pull pants up on their own. This could include anyone with Becker's Muscular Dystrophy or any other type of muscular dystrophy that limits one's arm and length strength.

B. Existing Designs/Treatments

Three current existing designs that assist with the issue of pulling pants up are the Pants Up Easy, The No Limbits Adaptive Mens Wheelchair Pant, and the Wings Pant Dressing Aid.

The first is The Pants Up Easy [3]. This is a large metal frame device that can roll behind the user and lock in place. The device features padded armrests that allow the user to put their armpits over the pads and lift themselves so they can slide their pants fully over their bottom. This method is effective at fully removing the bottom from the wheelchair so the pants can be pulled to the waist. However, The Pants Up Easy is very expensive and can not assist users with limited arm strength who can not lift themselves.

The second design is called the No Limbits Adaptive Mens Wheelchair Pant [4]. This device is a pair of wheelchair pants that zip from the knee to the waist and have snaps at the top to easily slide pants on. This device is relatively inexpensive and helps aid in the issue of getting pants to the waist. The caveats of this device are that it only solves the issue of the pants from the knee and doesn't help the user get their bottom off the chair. The design also replaces the user's current wardrobe which is not cost effective for the user.

The third design is the Wings Pants Dressing Aid [5]. This device contains two wing-like appendages that can open and hold open the opening of the pair of pants and allow the user to slide their feet up and pull up on a handle from a seated position so the pants can slide over the legs. This design also would not work for the client since the main issue is getting the pants up past the bottom. While these designs are very innovative, they are not ideal for the client based on physical limitations and personal opinions.

C. Problem Statement

A person with Becker's Muscular Dystrophy can have physical limitations that make it difficult to perform activities such as pulling up pants while sitting in a wheelchair. Current solutions are costly and require too much arm strength or assistance finishing the task from able-bodied caregivers. The goal of this project is to create a prototype solution that allows someone in a wheelchair with a maximum arm strength of lifting 8.4 lbs to independently pull up their pants past their knees without assistance.

II. Background

A. Physiology and Biology

Becker muscular dystrophy is an X-linked recessive disorder due to a mutation in the dystrophin gene, resulting in progressive muscle degeneration and proximal muscle weakness [2]. The defective gene is located in the Xp21.2 chromosome, and the defect is inherited as an X-linked recessive trait, so it almost exclusively affects males. Patients without a clear X-linked pattern of inheritance may have defects in other genes, affecting the dystrophin-associated glycoproteins. Becker affects people of all ages, mainly ranging from 5-60 years old and is inherited, so having a family history raises risk. The disease occurs in about 3 to 6 out of every 100,000 births [6]. Becker muscular dystrophy is very similar to Duchenne muscular dystrophy, which is more severe and early onset and patients usually have lower dystrophin concentration. The main difference is that it gets worse at a much slower rate and it is less common.

Muscle weakness of the lower body, including the legs and pelvis area, slowly gets worse, causing difficulty walking that gets worse over time; by age 25 to 30, the person is usually unable to walk. Weakness in the arms, neck, and other areas can be affected, however, not as severe as in the lower body. This causes frequent falls, difficulty moving, and loss of muscle mass, leading many to be confined in a wheelchair, while others may only need to use walking aids such as canes or braces.

There is no known cure for Becker muscular dystrophy. However there are many new drugs currently undergoing clinical testing that show significant promise in treating the disease. The current goal of treatment is to control symptoms to maximize the person's quality of life. Some providers prescribe steroids to help keep a patient walking for as long as possible. Chances

of survival are most often shortened if there are heart and breathing problems and in some circumstances, death usually occurs due to dilated cardiomyopathy.

B. Design Specifications

The main goal of this project is to create a functional product that assists in the process of pulling the clients pants up while confined to a wheelchair, especially from knees and above, and should minimize the time taken to pull pants up from seven minutes to around three minutes. It should support the weight and height of a 100-105 kg, 186 cm tall male. The device is intended for use in the home, mainly in the bedroom and bathroom and should be made out of materials compatible with an indoor environment temperature(20-25 °C) and humidity (40-60%) [2] and be durable enough to be usable for five years, without the risk of failure. Any component of the device that the client needs to lift in order to operate the device needs to be under 3.81 kg to accommodate the client's limited arm strength. The product cannot exceed the size of the wheelchair by more than 30 cm around the wheelchair; no larger than 122 cm tall, 182 cm wide, and 152 cm long. The device will be a Class I medical device according to the FDA [7] and should cost within the budget of \$300. A full and detailed analysis of the design specifications is laid out in the PDS (see Appendix A).

C. Client Information

Mr. Dan Dorszynski grew up in Wisconsin and has studied both civil and environmental engineering at Stanford. Mr. Dorszynski has Becker's muscular dystrophy and uses an electric wheelchair to get around. The action of putting on pants is difficult for him, especially past the

knees, as he often has to keep leaning and pulling, which takes him about seven minutes to do, and is looking for a way to reduce the time and effort needed.

III. Preliminary Designs

A. Lean & Lift

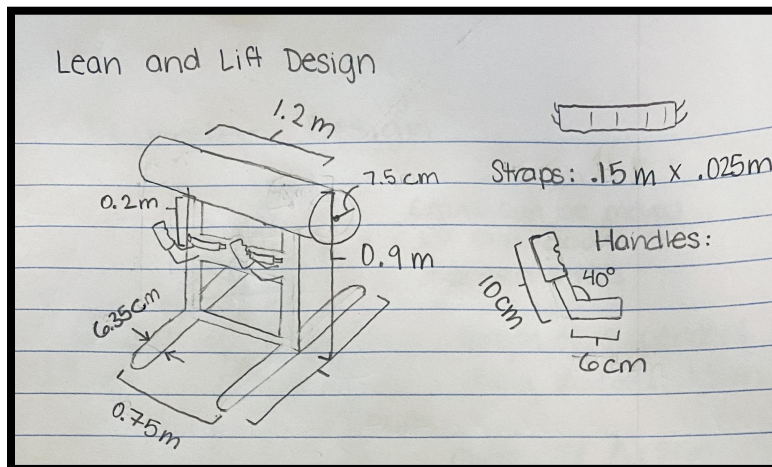

Figure #1: Lean and Lift Design Diagram

The Lean and Lift design incorporates an aluminum frame that would support a cylindrical cushion. The design would be used so that the client can get into a raised tilting position in their electric power wheelchair, which would roll on top of the aluminum beams on the floor for stability, and then lean onto the cushion in a supported standing position. In this position, the client would be able to pull up their pants without the inhibiting friction of the wheelchair seat without assistance. There would also be handles and straps for the client to grab on to for increased stability during the process of getting in and out of the assisted leaning position.

B. Snap/Zip Pants

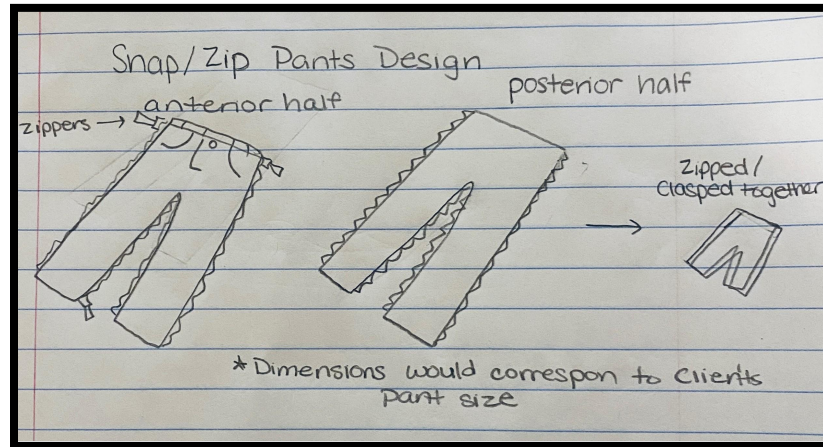

Figure #2: Snap/Zip Pants Design Diagram

The Snap/Zip pants design would involve two halves of a pair of pants that could be fastened together to fully put on a pair of pants in the sitting position. The pants would be divided by a frontal plane cut, creating posterior and anterior halves. The edges of these halves would be fitted with either snaps or zippers that can align together to unite the two halves of the pants to create a normal pair of pants. To put on the pair of pants, the client would place the posterior half of the pair of pants on their wheelchair before getting in it, sit down into the wheelchair, then place the anterior half of the pair of pants on top of their legs. From there, the client would either zip the zippers or snap the clasps that would run along the aligning edges of each half, assembling one pair of pants.

C. Suspenders

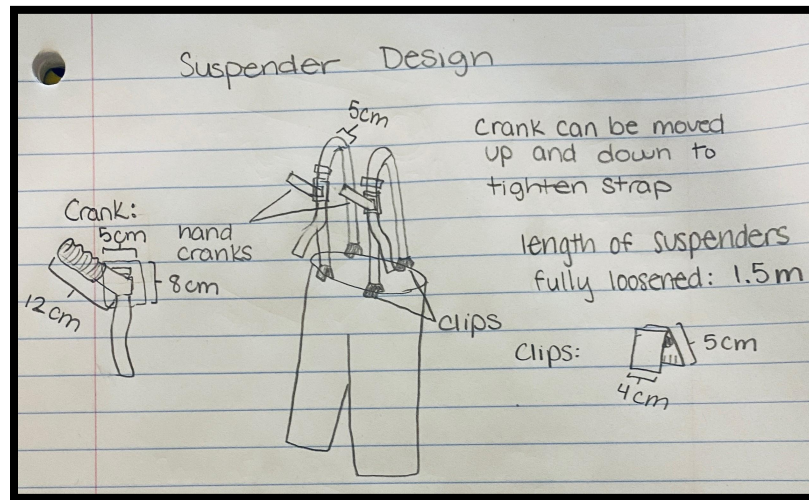

Figure #3: Suspender Design Diagram

The Suspender design would allow the client to pull up their pants by using a cranking suspender design to mechanically pull up their pants via a ratchet crank. The design would incorporate an outfitted pair of suspenders with clips that would attach to the posterior and anterior sides of the pair of pants. It would have a cranking mechanism that would allow the client to use the hand crank that tightens the posterior side of the suspenders, pulling up the last 6 inches of their pants up to allow the client to fully get dressed.

IV. Preliminary Design Evaluation

A. Design Matrix

Table 1: Design Matrix of the three prototypes discussed above. Criteria are outlined on the left with the category winner highlighted in light green and the winning design highlighted in dark green.

Categories	Lean and Lift		Snap/Zip Pants		Suspenders	
Effectiveness (25)	9/10	22.5	6/10	15	7/10	17.5
Ease of Use (25)	8/10	20	4/10	10	6/10	15
Ease of Fabrication (20)	7/10	14	6/10	12	8/10	16
Comfort (15)	10/10	15	9/10	13.5	6/10	9
Price (10)	5/10	5	10/10	10	10/10	10
Safety (5)	9/10	4.5	10/10	5	9/10	4.5
Total (100)		81		65		72

Once the product design specifications were fully developed, design criteria were generated to evaluate the effectiveness of the proposed designs. The designs were evaluated using the following criteria: Effectiveness (25), Ease of Use (25), Ease of Fabrication (20), Comfort (15), Price (10), and Safety (5).

Effectiveness:

The ability to effectively pull up the client's pants is one of the most vital requirements of the device, so it is weighted the highest. The effectiveness describes how well the device improves the ability of the client to put on their pants relative to their current method. The efficiency and amount of time required to put on the pants are the two main factors in the effectiveness category, the device should allow the client to pull their pants fully over the bottom in less time and with less stain than current methods. The Lean and Lift design scored highest as the simple design would solve the most significant current problem for the clients, lifting his bottom off the wheelchair seat, allowing the client to fully pull his pants up without the friction of the seat.

The Suspenders design was second as the potential for electric crank could make the design hands free, but this device does nothing to address the friction between his bottom and the wheelchair. The Snap/Zip pants scored lowest due to the potential alignment issues in both placing and putting the pants together.

Ease of Use:

Ease of use is defined as the amount of effort required to use the device and pull up pants. Ease of use is also weighted highest because a major requirement for the design is that it makes it easier for the client to pull up pants relative to current methods. The Lean and Lift scored the highest because the client does not have to transition out of his wheelchair, only lean forward using the controls already built into his wheelchair.

The Suspenders scored in the middle since the device is simple to use but it may be difficult for the client to attach his suspenders to his pants properly. The suspenders could require more force than the client can easily offer, making it difficult and inconvenient to use.

The Snap/Zip Pants scored lowest for this criterion because the client's lack of hand dexterity would make it very difficult to align zippers or snap many snaps.

Ease of Fabrication:

Ease of fabrication considers how difficult the device will be to fabricate considering materials and resources required, time limitations, and effort to complete. Ease of fabrication is weighted relatively highly because the design must be feasible to fabricate within the constraints, but it is not quite as important as the client's experience with the design. The Suspenders design scored the highest because the design consists of simple parts that could be sourced and combined, but would need to be tested with the client for ergonomic purposes. The Lean and Lift design scored closely behind because there are several options for purchasing prefabricated parts and modifying them to fit the design, but this design would require the most mechanical knowledge and safety testing. The Snap/Zip Pants design scored the lowest because while the design is simple, it would be logistically difficult to modify all of the client's existing pants and source a tailor or learn to sew.

Comfort:

The comfort of the design is defined as the comfort of the client while using the device. Since the device will be used daily, it is important for the device to be comfortable to use and should not put the client in any uncomfortable positions for a prolonged period of time. Based on

client feedback, comfort is weighted less highly since a more efficient device is preferred even if comfort is slightly sacrificed. The Lean and Lift design scored highest in comfort as the padded cylindrical cushion that would be leaned on will be soft enough to not cause irritation on the abdomen yet firm enough to keep the patient in place and can be operated within the clients wheelchair. The Snap/Zip Pants design scored closely behind as the pants that would be worn by the client would be similar to regular pants, but the zippers or snaps could potentially cause slight irritation to the skin. The Suspender design scored lowest as the suspenders could cause irritation when rubbing up against the body and the continually cranking of the suspenders could cause discomfort and muscle fatigue.

Price:

Price is defined as the total cost to produce the device. Provided with a flexible budget, price is weighted less. The initial budget allotment will be increased if a more ambitious design is selected that can improve the dressing experience significantly for the client. The Zip pants scored highest because the materials would mainly be fabric for the pants and zippers and sewing materials which would be well within the budget of the project. The Suspender design scored equally high because the materials would once again be fabric and ratchet cranks which are well within the budget of the project. The Lean and Lift scored lowest in price because the device would require the most amount of material including more expensive materials such as the metal and padding.

Safety:

Safety is the lowest consideration for the designs based on client feedback. The device must be used while the client is in a wheelchair and the act of pulling up pants is a low risk activity. Initial evaluations of the designs found that any design that had a potential questionable safety level was also very ineffective and were eliminated. The Snap/Zip Pants scored highest for safety because this product allows him to stay seated the whole time and snaps/zippers pose no risk to safety to operate. The Lean and Lift scored closely behind because the only feature allows the client to keep his feet on the ground and only leans his body forward, allowing him to stay safe and near his wheelchair. The Suspenders scored equally because the ratchet feature of the design could pinch fingers, but don't pose a significant safety threat.

B. Proposed Final Design

Based on the criteria above, the Lean and Lift design scored most highly. After reviewing the designs with the client, it was decided to combine the Lean and Lift with the second highest scoring Suspenders design. This design combines the best aspects of both designs. The main issue with the Suspender design was that it did not elevate the client's bottom off of his wheelchair seat, combining it with the Lean and Lift design eliminates this problem and brings in the Lean and Lift's superior aspects of effectiveness, ease of use, and comfort. The Suspenders were deemed to be the easiest to fabricate and the best price, so this design should not significantly increase the burden of fabricating the final design.

V. Fabrication/Development Process

A. Materials

For the lean and lift device, a combination of Aluminum (Al) and cushion material will

be used. T6 aircraft grade Al is used for wheelchairs [8], which makes it a good contender for the lean and lift base to uphold a 230 lb weight. The cushion material will replicate a doctor's exam table material that is comfortable and sturdy. The suspender device will include an RC winch that will allow the user to use a remote control to activate the pulling up of pants mechanism. The RC winch requires an RC transmitter and receiver, batteries, and an electronic speed controller (ESC). The suspenders will be purchased from an existing design of suspenders with adjustable straps, non-elastic webbing, and low stretch ability.

B. Methods

The suspenders will be attached to the RC winch using washers, nuts, and bolts. The winch will be placed near the center of the suspenders to level the weight distribution. The propeller of the RC winch will connect to the motor shaft. After the batteries and the ESC are fastened, the motor can be connected to the ESC and receiver. The last step to set up the RC winch is to set up the RC transmitter to control the motor's speed and direction. More research into RC winch components assembly will need to be done so the team can put the device together correctly. The lean and lift device will need the metal material chosen to be welded to the cushion material using a proper adhesive.

VI. Testing

- I. **Client Strength Testing**: The client will lift varying amounts of weight from a seated position with one arm. If the client was able to pull the weight completely off of the ground, it will be marked as a success - if the client is incapable of lifting the weight off of the ground, it will be considered a fail. This strength testing is important because it gives a baseline evaluation of how much weight the client is capable of pulling. This will inform the team on how to design the leaning device so the client will never need to pull more weight than they are able to.
- II. **Lean Mechanism Stress Testing**: The lean mechanism will be the device in which the client will put a majority, if not all, of their body weight on. Therefore evaluating the maximum amount of stress that the device can withstand is essential to the completion of the project. The team will design the prototype on Solidworks, from here the team will use the testing mechanisms of the application to determine the theoretical maximum stress, and weight the device can withstand. Once the team has designed a device that is able to withstand the full body weight of the client, 108 kg, then the prototype will be built. Another stress test will occur with the physical prototype to ensure that the real product is capable of withstanding the same forces as simulated.
- III. **Suspender Strength Testing**: The suspender strength testing will evaluate the amount of weight that the electrical motor is able to pull. The average weight of an individual's pants is 0.4 kg, so the minimum amount of weight that the motor should be able to pull is 0.4 kg. This test will be conducted via a tension measuring device that is attached to the motor. This test will ensure that the suspender part of the design is functional, if this part is non-functional then the device will not meet the basic requirements of assisting the

client pull their pants up.

- IV. Suspender Path Testing: This test will consist of pulling the suspenders up from a variety of different angles to determine which one is the best. Different positions may lead to a varying degree of resistance when the pants are being pulled up, so the client's evaluation of which path feels the most comfortable and is the most effective is imperative. This will fulfill the requirement for the device to be effective in pulling the pants up, and in being comfortable for the client.

VII. Results

- I. Client Strength Testing: From a seated position, the client lifted a bag with a cushioned handle from the ground. Lift attempts where the bag was fully off the ground were marked as a pass, and attempts where the client was unable to lift it fully off of the ground were marked as a fail.

Trial	Weight (kg)	Outcome
1	1.27	Pass
2	2.27	Pass
3	3.81	Pass
4	5.80	Fail

Table 2: Results from the client strength testing

The client also stated that trial 3's weight was close to the maximum pulling strength that they are able to exert.

As of October 11, 2023, there are no results in regards to the rest of the prototype tests since none of the tests have been performed. To gather results, the team will need to attain the necessary materials to construct the prototype and then perform the tests.

VIII. Discussion

From the client strength testing, the team ascertained that the total pulling force of the client does not exceed 7.62 kg. This pulling force will be taken into account when designing the leaning part of the final prototype. Since the client has a pulling force that is drastically less than their total mass, 108 kg, a device in which a minimal amount of effort from the client will be necessary. Because of this, a leaning device that is much lower, relative to the client's position in the wheelchair, will be ideal since gravity can be used to pull the client over the leaning device. After completion of all the testing, the team will be able to determine which materials and suspender angle perform the best in completion of the goals laid out in the PDS.

Since the product is for the client, continuous work with Dan Dorszynski will happen to ensure the success of the final design. To eliminate bias and error in testing, all final physical tests will be conducted with the client using the product to maximize satisfaction. Discomfort, dislikes, and suggestions will be noted and the feedback will be implemented to the best of the team's ability.

If the product is unable to be completed on time, it could lead to the dissatisfaction of the client and a prolonged period in which a less ideal way of pulling up their pants. However, if the final product is rushed and proper safety testing is not completed, it could lead to potential harm to the client if the product were to fail and break during use. So the team must work efficiently to properly meet all design requirements and finish in the limited time of the semester.

IX. Conclusions

Everyone deserves to have their own autonomy and have the tools they need to be independent. Dan Dorsynski, the client and a man with Becker's muscular dystrophy, has physical limitations that prevent him from being able to pull his pants up all the way. By creating a device that would aid the process of the client getting dressed in the morning, his life can be made easier by saving him time and effort when getting ready independently.

The design used to aid Dan's dressing process is an aluminum frame-supported cushion that he can lean on, in addition to a suspender component that would clip onto his pants and electronically tighten the straps of the suspenders to pull his pants up. Once clipping his pants onto the suspenders, putting the suspenders over his shoulders, and getting into the supported leaning position on the cushion, Dan would be able to push a button to tighten the suspenders, pulling up his pants all the way and allowing him to get dressed in a much faster and easier fashion than before.

From this point, further testing will be done to ensure that the materials used in the design would be strong enough and that the electronic crank system would successfully tighten the suspender straps and furthermore pull up the client's pants. In addition, after further prototyping and ordering of materials, the final design can be assembled and become usable to the client.

X. References

- [1]“Guidelines on the provision of manual wheelchairs in less resourced settings,” *www.who.int*.
<https://www.who.int/publications/i/item/9789241547482>
- [2]P. K. Thada, J. Bhandari, and K. K. Umapathi, “Becker Muscular Dystrophy,” *PubMed*, 2020.
<https://www.ncbi.nlm.nih.gov/books/NBK556092/>
- [3]“Helping Wheelchair Users And Others With Mobility Impairments To Pull Up Their Pants Independently,” *Pants Up Easy*. <https://www.pantsupeasy.com/>
- [4]“No Limbits,” No Limbits. <https://no-limbits.com/>
- [5]“Wings-Pants Dressing Aid: Put On Pants Easier,” The Wright Stuff, Inc. | CareGiverProducts.com. <https://www.caregiverproducts.com/wings-pants-dressing-aid.html>
- [6] “Becker muscular dystrophy,” Mount Sinai Health System,
<https://www.mountsinai.org/health-library/diseases-conditions/becker-muscular-dystrophy>
- [7] Center for Devices and Radiological Health, “Classify Your Medical Device,” U.S. Food and Drug Administration,
<https://www.fda.gov/medical-devices/overview-device-regulation/classify-your-medical-device#:~:text=Class%20I%20includes%20devices%20with,I%2C%20II%2C%20and%20III.> (accessed Sep. 19, 2023).
- [8]“Durable Wheelchairs: What is the best type of material to buy,” *Karman® Wheelchairs*, Jul. 30, 2013.
<https://www.karmanhealthcare.com/durable-wheelchairs-best-material/#:~:text=For%20example%2C%20Aircraft%20grade%20aluminum>

XI. Appendix

A. Product Design Specifications

Function:

Muscular dystrophy (MD) is a genetic disease that causes progressive weakness and degeneration of skeletal muscles. A patient with Becker's MD, a type of MD caused by a mutation in the dystrophin gene [10], has physical limitations that make it difficult to pull up their pants all the way when getting dressed. The pants can be pulled up to the knees easily, and then a combination of leaning and pulling, along with frequent assistance, is needed to get the pants where they need to be. The total time taken is around 7 minutes. To minimize the time taken and eliminate the stress caused on the patient to pull up the pants, a two-part assistive device can be used. The first part of the system, the Lean and Lift device, is a stand-alone device that when positioned in front of the user, will allow the user to lean over the top to raise the lower body off the wheelchair. The Lean and Lift will be able to withhold a 230-lb, 6-ft-2-in male. The second part of the system, the Suspender device, will attach to the pants when at the knees and go around the shoulders. When the user is in the leaned-over position on top of the Lean and Lift device, the user will pull a string, attached to the suspenders, that will pull the pants up until comfortable. The amount of arm strength provided by the user with MD is limited, so the entire system will not require lifting more than 8.4 lbs. The time required to operate the device should not exceed 3 minutes.

Client Requirements:

- Functional product that assists the process of pulling pants up while sitting in a wheelchair, especially from knees and above

- Support the weight and height of 220-230 pound, 6-foot-2-inch tall male
- Must be usable without fully standing up
- Materials must be durable enough to be usable for 5 years
- Budget must be within \$300

Design Requirements:

1. Physical and Operational Characteristics

- Performance Requirements:* The lean and lift device will allow the user to safely get out of a wheelchair without risk of the user falling or the device slipping on the ground. The lean and lift device will support a 230 lb weight and not cause any discomfort to the user on the upper body. The suspenders device will pull pants from knees to the waistline without the risk of coming unattached from the pants or sliding off the shoulders during operation. The lean and lift and suspenders system will pull the user's pants up without the need of assistance in about 3 minutes.
- Safety:* The device should withstand 230 pounds of force for 5 years, without the risk of failure. All mechanical parts must be without sharp edges or pinch points to prevent user injury. For possible electrical elements, the device should ensure operation on a low voltage to minimize the risk of electric shock. The device should implement fire-resistant materials in areas where the risk of sparks or high temperatures is present. The device must adhere to relevant safety standards for

machinery safety and risk management in medical devices. Clear user instructions should be given to the user to ensure safe and effective use.

- c. *Accuracy and Reliability:* The suspenders device should pull up pants from the knees to fully over the client's bottom without exertion on the client or any assistance. The lean and lift device should lift the user's lower body off the wheelchair without the risk of fall. The lean and lift device should hold up a force of 230 lbs during operation. The device should continue to pull up the client's pants up to 10 cycles daily and continue to function for at least 5 years without failure.

- d. *Life in Service:* The device should minimize the time taken to pull pants up from 7 minutes to around 3-4 minutes. The device is to be used every time the client puts on a pair of pants. The device should have easily repairable components with the intention that the device can be used for at least 5 years by the client without modification.

- e. *Shelf Life:* The device should remain fully functional for 5 years and its components can be replaced or fixed easily.

- f. *Operating Environment:* The device is intended for use in the home, mainly in the bedroom and bathroom. The device should be made out of materials compatible with an indoor environment temperature(20-25 °C) and humidity (40-60%) [10].

The lean and lift device may be free-standing, attached to the client's wheelchair, or mounted on a wall.

- g. *Ergonomics*: The device will accommodate a patient with a height of 6-ft-2-in and a weight ranging from 220-230 lbs. The device should be under 50 pounds and after the device is initially set up, no component should require more than 8.4 pounds of arm strength to operate. Large, easy-to-grab knobs and handles should be integrated into the design to minimize the force needed for usability. The device should have a textured surface for the components to be easily grasped if needed. The device should not cause any unnecessary strain or fatigue.
- h. *Size*: The product cannot exceed the size of the wheelchair by more than 1 foot around the wheelchair; so no larger than 4 ft tall, 6 ft wide, and 5 ft long.
- i. *Weight*: Any component of the device that the client needs to lift in order to operate the device needs to be under 8.4 lbs to accommodate the client's limited arm strength. The total weight of the device may be up to 50 lbs since it does not need to be moved by the client once initially set up with assistance.
- j. *Materials*: The device could be made out of several different materials depending on the design chosen. For the lean and lift device, Aluminum alloy is a possible choice for the legs and base. A cushion material should be used for the part of the lean and lift system where the user puts their weight on.

k. *Aesthetics, Appearance, and Finish:* The color scheme of the product should prioritize clarity and visibility. High-contrast color combinations like white/black [1] should be used for controls and indicators. The device's shape should complement the user's body movements when pulling up pants and wheelchair configuration. For a handheld device, the texture should exhibit the following characteristics: soft, non-shiny, smooth, warm, and non-sticky to optimize the user's grip [2]. A handle bar will be attached to the lean and left device in a way that will reduce the risk of the user falling off.

2. Production Characteristics

- a. *Quantity:* One prototype for individual use by the client is needed.
- b. *Target Product Cost:* The client desires a functional prototype within a \$300 budget.

3. Miscellaneous

- a. *Standards and Specifications:* The device will be a Class I medical device according to the FDA [3]. Relevant FDA regulations include:
 - i. Electronic Product Radiation Regulation - 21 CFR 1000.1 [4]
 - ii. Establishment Registration - 21 CFR Part 807 [5]

The device will also be required to follow Rehabilitation Engineering and Assistive Technology Society of North America (RESNA), which specifies standards for wheelchairs, wheelchair devices, and scooters [6]. Such regulations and standards include:

- i. RESNA WC-1 Wheelchairs – Volume 1: Requirements and Test Methods for Wheelchairs (including Scooters)
 - ii. RESNA WC-2 Wheelchairs – Volume 2: Additional Requirements for Wheelchairs (including Scooters) with Electrical Systems
- b. *Customer:* The client is Mr. Dan Dorszynski. He grew up in Wisconsin and has studied both civil and environmental engineering at Stanford. Mr. Dorszynski has Becker’s muscular dystrophy and uses an electric wheelchair. The action of putting on pants is difficult, especially past the knees, as he often has to keep leaning and pulling, which takes him about seven minutes to do and a lot of effort. He typically wears athletic pants, such as golf pants that have belt loops. Mr. Dorszynski has voiced he doesn’t mind if the solution is electric, manual, cloth, or any specific material/device.
- c. *Competition:* There are a few similar items that aid people with pulling up their pants. One of the most popular products is one called Pants Up Easy. This device can either be attached to the wheelchair, wall, or portable. It is made up of two pads that lie above the user’s shoulders so they can hoist themselves up, allowing them to pull up their pants. Pants Up Easy is very costly, ranging from \$1500 to \$3600, depending on the model [7]. Another is called the Wings-Pants Dressing Aid, which is a much cheaper option, retailing for \$49.50. The product holds the pants open and is easily adjustable by opening the release and pulling outward,

allowing the user to slide up the device and pants simply [8]. Both designs are efficient, but costly and require sufficient arm strength.

References:

- [1] Hillman, M., Hagan, K., Hagan, S., Jepson, J., & Orpwood, R. (2002). The Weston wheelchair mounted assistive robot - the design story. *Robotica*, 20(2), 125-132.
doi:10.1017/S0263574701003897
- [2] Hengfeng Zuo, Mark Jones, Tony Hope & Robin Jones (2016) Sensory Perception of Material Texture in Consumer Products, *The Design Journal*, 19:3, 405-427, DOI: 10.1080/14606925.2016.1149318
- [3] Center for Devices and Radiological Health, “Classify Your Medical Device,” U.S. Food and Drug Administration,
<https://www.fda.gov/medical-devices/overview-device-regulation/classify-your-medical-device#:~:text=Class%20I%20includes%20devices%20with,I%2C%20II%2C%20and%20III.> (accessed Sep. 19, 2023).
- [4] Center for Devices and Radiological Health, “Does the Product Emit Radiation?,” U.S. Food and Drug Administration,
<https://www.fda.gov/medical-devices/classify-your-medical-device/does-product-emit-radiation> (accessed Sep. 19, 2023).
- [5] Center for Devices and Radiological Health, “Overview of Device Regulation,” U.S. Food and Drug Administration,
<https://www.fda.gov/medical-devices/device-advice-comprehensive-regulatory-assistance/overview-device-regulation> (accessed Sep. 19, 2023).

[6] “Resna Standards Committee on wheelchairs (including scooters) (WCS),” RESNA, <https://www.resna.org/AT-Standards/Wheelchairs-WCS> (accessed Oct. 4, 2023).

[7] “Helping wheelchair users and others with mobility impairments to pull up their pants independently,” Pants Up Easy, <https://www.pantsupeasy.com/>

[8] “Wings-Pants Dressing Aid: Put On Pants Easier.” The Wright Stuff, Inc. CareGiverProducts.Com, www.caregiverproducts.com/wings-pants-dressing-aid.html.

[9] Park HJ, Lee SG, Oh JS, Nam M, Barrett S, Lee S, Hwang W. The effects of indoor temperature and humidity on local transmission of COVID-19 and how it relates to global trends. PLoS One. 2022 Aug 10;17(8):e0271760. doi: 10.1371/journal.pone.0271760. PMID: 35947557; PMCID: PMC9365153.

[10] Thada PK, Bhandari J, Umapathi KK. Becker Muscular Dystrophy. [Updated 2023 Jul 19]. In: StatPearls [Internet]. Treasure Island (FL): StatPearls Publishing; 2023 Jan-. Available from: <https://www.ncbi.nlm.nih.gov/books/NBK556092/>

B. Materials and Costs

Currently, no materials have been purchased as the team has yet to begin manufacturing a physical prototype. Below is an example expense table that will be updated as materials are purchased.

Table 3: Expense Table

Item	Description	Manufacturer	Mft Pt#	Vendor	Vendor Cat#	Date	QTY	Cost Each	Total
Lean and Lift Device									
UHMW Rod	3" Diameter HDPE Rod, 6" Length	MSC Industrial Supply	551520 2	MSC Industrial	524327 54	3/28/2023	2	\$1.93	\$3.86

				Supply					
Suspender Device									
RC Winch									
Suspenders									
								TOTAL:	\$9.01

<https://www.suspenderstore.com/shop-by-material/non-low-stretch-work-suspenders/>

https://www.amazon.com/INJORA-Automatic-Wireless-Remote-Controller/dp/B083ND79RC/ref=sr_1_3?hvadid=616931486605&hvdev=c&hvlocphy=9018948&hvnetw=g&hvqmt=e&hvrnd=1162112257770052231&hvtargid=kwd-10882232655&hydadcr=26613_11715044&keywords=rc%2Bwinch&qid=1696987118&sr=8-3&th=1