

# BioMems Photomask Aligner

## Preliminary Report

Biomedical Engineering Design 200/300

Lab 306

Department of Biomedical Engineering

University of Wisconsin – Madison

Nov 1, 2023

### **Team Members:**

Jayson O'Halloran – Co-Leader

Emily Stoebe - Co-Leader

Saketh Peddireddy – BSAC

Paulie Reuteman – BWIG

Luke Waldhuetter – Communicator

George Haron – BPAG

### **Client:**

Dr. John Puccinelli

Department of Biomedical Engineering

University of Wisconsin – Madison

### **Advisor:**

Dr. Josh Brockman

Department of Biomedical Engineering

University of Wisconsin – Madison

# Table of Contents

<b>Table of Contents</b> .....	<b>2</b>
<b>Abstract</b> .....	<b>3</b>
<b>Introduction</b> .....	<b>3</b>
Motivation.....	3
Current Devices.....	3
Problem Statement.....	4
<b>Background</b> .....	<b>4</b>
BioMEMS.....	4
Research Required to Build Prototype.....	4
Client information.....	5
Rotating Tower.....	6
Arm-Pin Alignment.....	7
Screw Design.....	10
<b>Preliminary Design Evaluation</b> .....	<b>16</b>
Design Matrix.....	16
Proposed Final design.....	19
Materials.....	19
Methods.....	19
Final Prototype.....	20
Testing/Future Work.....	20
<b>Discussion</b> .....	<b>20</b>
<b>Conclusion</b> .....	<b>21</b>
<b>References</b> .....	<b>21</b>
<b>Appendix</b> .....	<b>23</b>
A. PDS.....	23

# Abstract

Biomedical Microelectromechanical Systems (Bio-MEMS) are biomedical devices with components generally measuring less than 100  $\mu\text{m}$ . They are often used to study interactions such as cell activity monitoring or biocompatibility testing. These devices are created using photolithography to transfer an image onto a photoresist substrate that can be cross linked with UV light. Consecutive layers of photoresist are added to create a three dimensional structure, and a typical device has three layers. When creating a new layer, the image mask must be precisely aligned with the layer underneath. There are many high fidelity aligners on the market, however these are extremely expensive and impractical for an educational setting. 4 cost efficient designs for alternative aligners have been proposed and evaluated. Based on the evaluations, a final design has been chosen for prototyping and testing.

## Introduction

### Motivation

The design project client and his students are having difficulty correctly aligning multiple layers which have inspired the client to theorize a photomask alignment device. This is an aligner that, theoretically, would be able to accurately align masks within a range of 10 to 100  $\mu\text{m}$ . Currently, manual alignment by the eye through a microscope is accurate in the range of 200 and 300  $\mu\text{m}$ . This difference in accuracy can cause mis-alignment and discrepancies in the three dimensional structure created by photolithography. This would then cause the client, or his students, to restart the mask alignment process from the very beginning. A more accurate alignment method/device would minimize material waste and reduce manufacturing time of the three layer stack.

### Current Devices

There are currently multiple methods of aligning photomasks for BioMEMS purposes. The first method is with the assistance of an electronic aligner. The EVG@610 Mask Alignment System [1] is an example of a compact and multipurpose R&D system that provides an accuracy of around 0.5  $\mu\text{m}$ . Electronic aligners such as this are very accurate, however are very costly; a used EVG aligner can cost over \$40,000. Benefits of this method include the high resolution and accuracy as well as versatility since most digital aligners can accept wafers sizes up to 200 mm. As a more cost-efficient alternative, Dr. Justin Williams at The University of Wisconsin – Madison uses a simpler machine. The system used by Dr. Williams utilizes manual alignment techniques such as gears and old microscope parts. The photomasks are taped to a piece of glass that separates the UV light source from the wafer. The UV light is mounted directly to the frame of the aligner. The glass then sits on the microscope stage and can be adjusted with the knobs located on the side of the device. Undesirable gear ratios and poor resolution associated with the microscope eyepieces provide an accuracy of 50-200  $\mu\text{m}$ . The final alignment technique is

another manual alignment technique in which everything is aligned by eye. Professor John Puccinelli, also from University of Wisconsin – Madison designs his photomasks in a CAD program, creating alignment marks on each mask. He then uses a microscope to try to align these marks of each of the masks. As can be expected, accuracy is by far the worst for this method providing around 200-300  $\mu\text{m}$  of accuracy.

### Problem Statement

Manual alignment of photomasks provides a layering accuracy of 200-300 $\mu\text{m}$ . The current process leads to discrepancies in the three dimensional structure created by photolithography. This leads to a waste in fabrication material, loss in time, and having to restart the alignment process. A more accurate way to align photomasks is needed for scenarios like these. The design should be easily usable by biomedical engineering students, be significantly lower in cost (<\$100), extremely repeatable and easy to construct with minimal tooling, and precise in accuracy (10-100 $\mu\text{m}$ ). In addition, the device should be able to be created using materials that are available in any local hardware store.

## Background

### BioMEMS

Biomedical/Biological Microelectromechanical Systems (BioMEMS) is the science of nanodevices in the fields of biology and medicine. There are many new applications of this technology in recent years ranging from new drug delivery techniques as well as implanted devices for medical monitoring [2]. In the scope of this project, the aligner will be used to create a microfluidic photoresist device that is helpful when studying cell cultures, biochemical assays, as well as many other research applications. A process called photolithography, which involves shining UV light through a photocurable epoxy is used when creating the photoresist layers.

### Research Required to Build Prototype

#### 1. Photolithography

In the project photolithography is used to create a multilayer system. The photolithography process starts with spinning a layer of SU-8 photoresist onto a silicon wafer. After this the wafer must be soft-baked in order to slightly harden the photoresist. After this, one must align the photomask over the wafer and then shine UV light through the photomask to transfer a pattern on the photoresist. The lab the client envisions this device for uses the OmniCure S1500 to cure the photoresist [3]. Then, one repeats the process of spinning on photoresist and curing patterns onto the wafer as many times as necessary. In the client's lab, the spin coater is a SCS P-6708 that is able to spin up to an 8 inch wafer at a range of 100-8000 rpm [4]. For this device, the client requested an aligner that can align up to 4 layers with varying sizes of silicon wafers. After the UV curing process is finished, then one hard bakes the layers and fully hardens the photoresist and cement it onto the wafer. Within the multilayer

photolithography process, the alignment of the photomasks on the silicon wafers is a critical step to ensure the accuracy of the device, this is because the patterns must overlap perfectly or with very little error in order for the final product to function correctly.

## 2. Current Laser Cutting and Printing Techniques

Photomasks are produced using high-resolution printers and are typically outsourced. However, most alignment methods do not specify a standardized technique for cutting the photomask from the transparency. Conventionally, photomasks are manually cut into various shapes and sizes using scissors. In the context of this project, there is a strong focus on exploring the use of a laser printer/cutter. The UW-Madison BME Department possesses a 40-Watt Epilog industrial printer that offers precise resolution control ranging from 75 to 1200 dpi, equivalent to a maximum resolution of 21 microns [5]. Utilizing this laser cutter to create specific geometries on the photomask transparency allows for precise control over the geometry, which is crucial for the alignment technique. Furthermore, the Maker Space at UW Madison is a collaborative and creative space that provides access to various tools, equipment, and resources for students and faculty to engage in hands-on projects, prototyping, and experimentation [6]. This area offers 3D printers, laser cutters, woodworking tools, electronics, and other equipment to support a wide range of engineering design projects, which will be of practical use in this design project.

### Client information

Dr. John Puccinelli is a faculty member within the department of Biomedical Engineering at The University of Wisconsin-Madison. He leads the BME Design curriculum and is also involved in the Biomedical Engineering teaching lab where he teaches with a hands-on approach in the fields of biomaterials as well as cell/tissue engineering. He is interested in the team creating this photomask aligner for use in the Biomedical Engineering teaching lab.

### Design Specifications

The client is requesting a budget of less than \$100 for the production of the device. The client is looking for accuracy in the range of 10-100  $\mu\text{m}$  when aligning the photomasks and the photomasks should be 10  $\mu\text{m}$  above the photoresist during the UV light step. The design needs to be able to be scaled for wafer sizes of 3", 4", and 6". The device is being created for a teaching lab so it must be easy to use as well as reproducible. There are no critical size or weight concerns but it will likely be used under a fume hood due to the SU-8 photoresist being used in the process [7]. It must fit under the fume hood and function properly in that environment. The product should be designed to last at least 10 years in service, it will be used in a lab environment but it will not need to be stored or used in a sterile environment. The goal is to produce one product as well as a set of instructions outlining how to recreate the process/properly the our device. Additionally, the team will be creating a stamp that allows for a user to accurately and efficiently punch holes into the photomasks to assist with the alignment process.

# Preliminary Designs

## Rotating Tower

The rotating tower idea is one that works as a swivel with the wafer sitting at the very bottom of this tower. The base has a rod sticking out of it with three platforms connected to it on a hinge. These three platforms would all hold a photomask within them for the three layers of photolithography that need to be completed to the wafer. Each layer of the tower would be 5 millimeters thick. Each layer would have a pin attached to it so the photomask could sit inside of it and be as flat as possible. The layers would also be able to be removed from the tower and their heights would be adjustable as well. The distance because of this between each mask is 5 millimeters. Each platform would be able to swing above the base when needed or be moved out of the way when unnecessary. The rotating tower is illustrated in Figure 1.

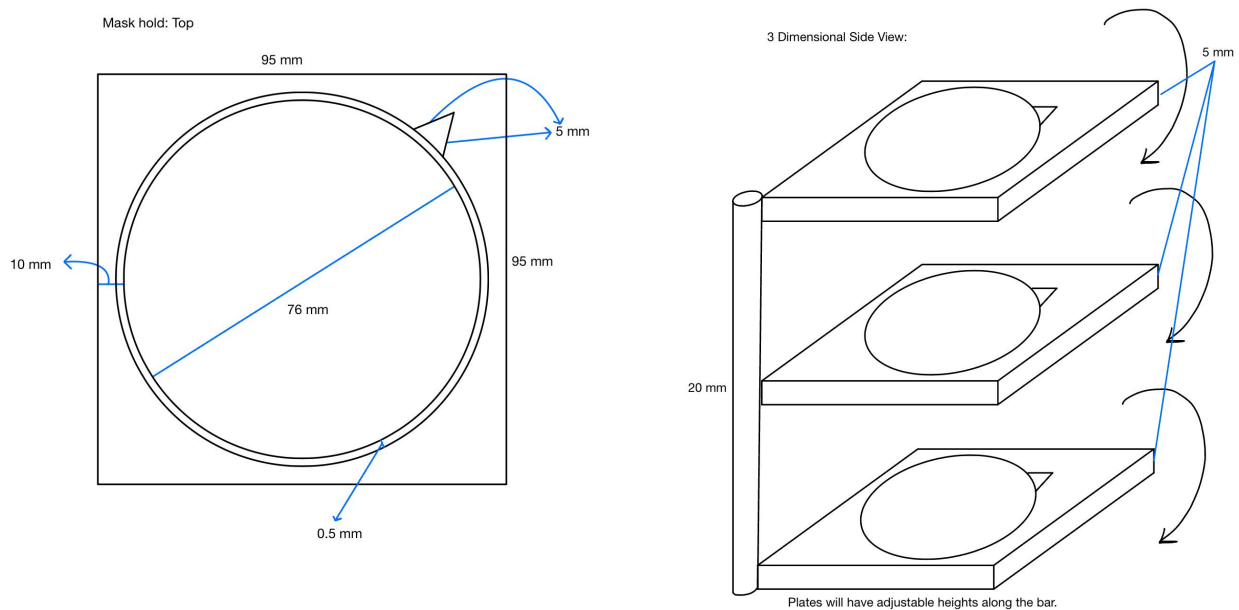

*Figure 1. Rotating Tower top view and base.*

Issues arise with this design when it comes to spacing. The platforms are 5 mm thick, which seems small, but there is still too much space between the masks to reach the 10  $\mu\text{m}$  spacing that the client requires between the masks. This would cause large issues with the accuracy of the aligned masks which would render the device unusable for the client's needs. The accuracy, however, is the only big downfall to the design. The ability to swivel and readjust the height of the masks makes the product very accessible. The accessibility of it combined with a low cost makes it an even more attractive design. The design would also be made with a

material that is baking resistant, so the ability to bake it minimizes the need to readjust the device and reinsert the wafer into the device, potentially decreasing the possible error.

### Arm-Pin Alignment

The arm pin alignment is a rectangular board with four sections in each of the corners. The four sections consist of: a laser cut divot for 3 inch wafers, a laser cut divot for 6 inch wafers, an arm with a pin measured to insert into the 3 inch wafer's hole, and an arm with a pin measured to insert into the 6 inch wafer's hole. On the laser cut side of the base there is a hole left to cut through the plastic section of the photomask (twice per mask). This design would have to use precise laser cutting techniques to get the most precision out of the holes to line up. Then, one can place the wafer with the spun photoresist in the correct position for either the 3 or 6 inch design. After cutting the photomasks with the laser cutter, the photomasks are inserted on the arm-pins where they will be aligned with the wafer underneath. The process of UV light can then begin. This process of setup is repeated for all the layers. The design is shown below in Figure 2.

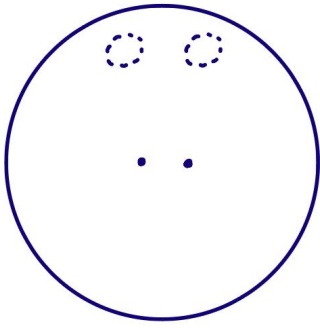

3 in

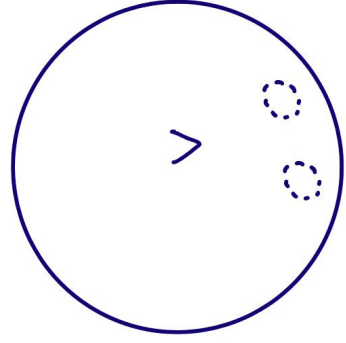
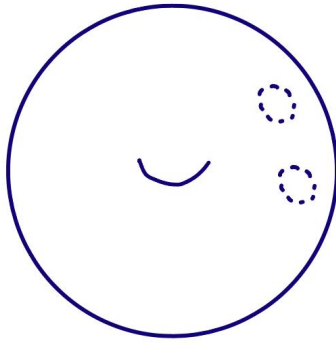

10 in



1 in



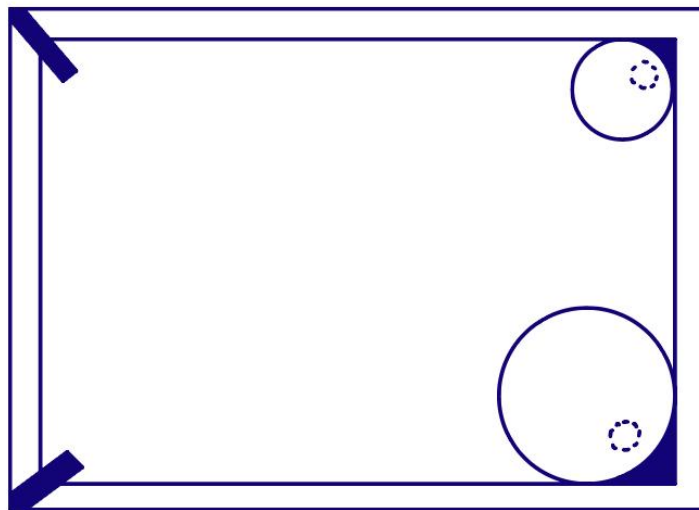
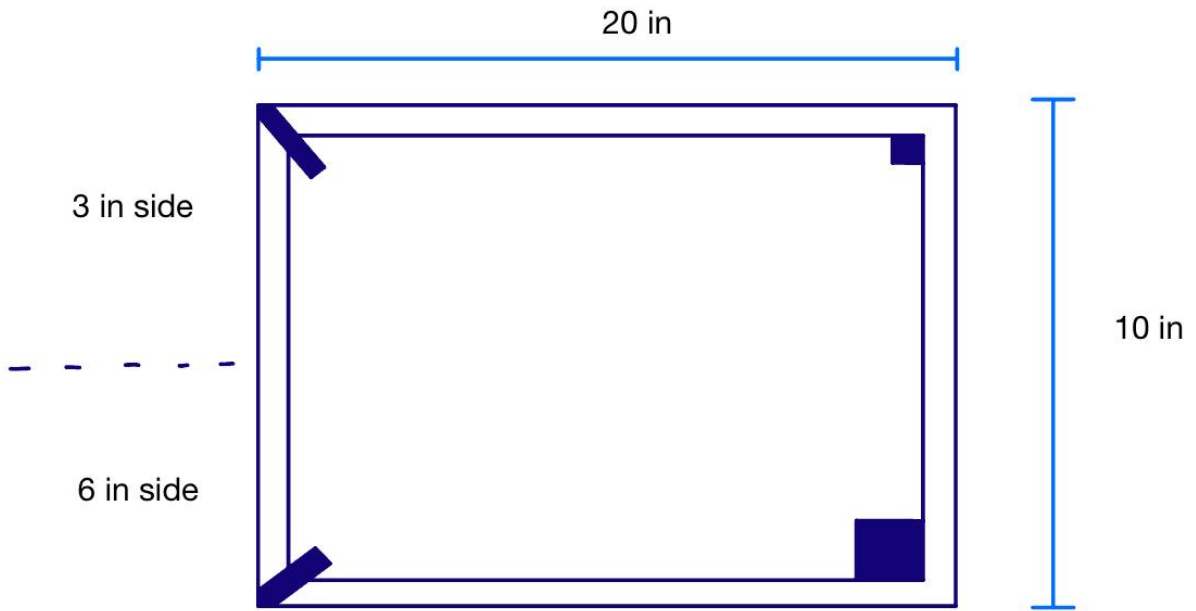

*Figure 2. Arm-Pin alignment diagram with mask example.*

The arm-pin alignment design is good in theory, but difficult to execute. It would have to be bigger than originally asked for to fit the four corners described in the design. The laser cut divot being included would also cause some problems. The laser cutter cannot make precise enough cuts to fit perfectly into the photomask. The laser cutter can be precise to 25  $\mu\text{m}$ , which is not accurate enough as the client wants it to be 10  $\mu\text{m}$ . The cost of this design may also exceed the price limit for the project.

### *Screw Design*

The screw design was a concept from the previous Bio-MEMS team, but re-designed by this year's group. The basis of the design was a platform with two rings, 3 and 6 inches respectively, that could hold the two different wafers provided by the client. The main platform would be 7 inches wide on each side, with the rings cut into it. This platform would have 2 pegs on each side of the circles cut out, that would allow the photomasks to be put on top of the wafers. The platform would then be attached to an almost "flood light" screw, which would be put into a box to keep it stationary. The screw would provide mobility and the ability to switch between wafers and masks quickly, as well as be able to bake the wafers right in it, as it would be made with acrylic, which is resistant to baking. The design is illustrated in Figure 3.

Top View

Top Piece

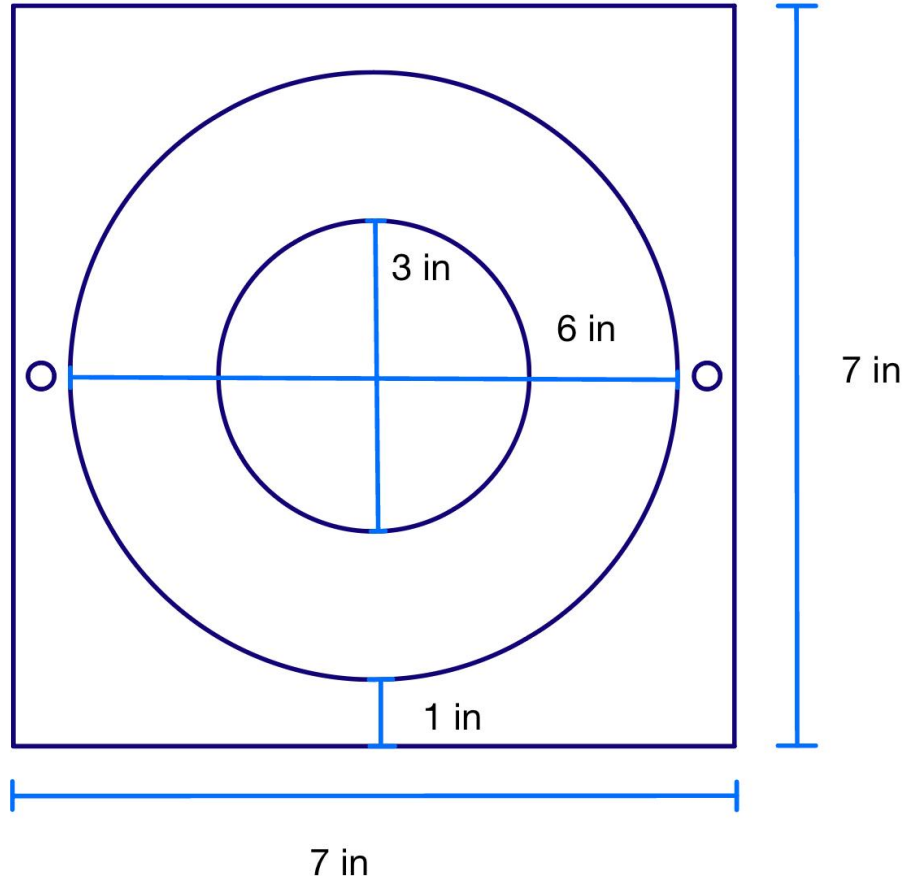

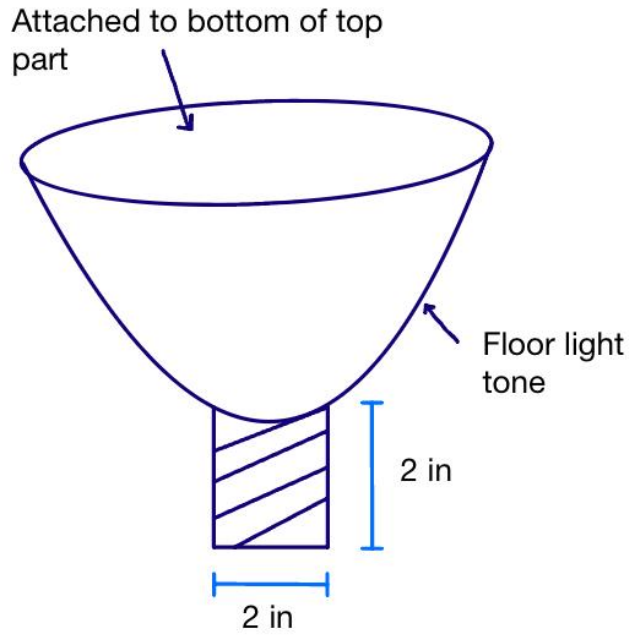
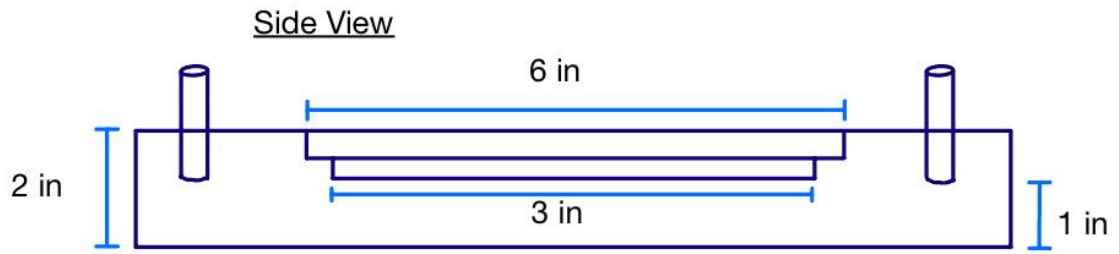

Diameter at top: 4 in

Height: 5 in

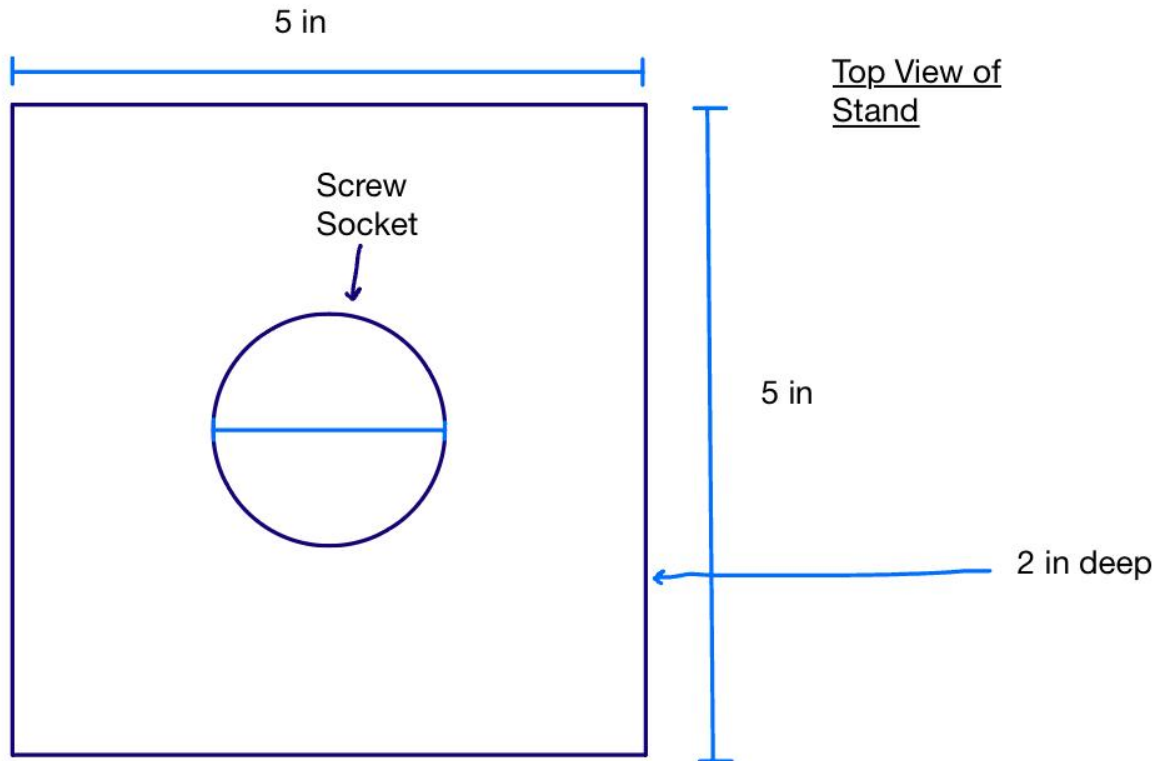

*Figure 3. Screw Design top and bottom piece dimensions.*

This is a fairly basic design, with some drawbacks. The constant screwing in and out would be tedious and would not be ideal for use in a teaching lab, especially considering that this device will be used only rarely (~2 weeks of the year). Along with that, the effectiveness would not be accurate. The client asked for minimal space between the masks and the wafer (10  $\mu\text{m}$ ). In the screw design, this space is almost impossible to achieve because of the design. There would be a bigger gap than asked for, which would lead to mistakes.

### Divot Design

The Divot design is a more complicated design than the others. It consists of a base, wafer holders, and alignment pillars. It also has a complimentary hole-punching stamp which is used to punch holes in the masks so that they can be properly aligned on the base using the alignment pillars. The Divot design features two alignment pins that are inserted flush into the base. The masks are then punched with the standardized hole-punching stamp so that they will fit onto the alignment pins exactly. The wafer with the spun photoresist will then be inserted into a wafer holder that corresponds to the space that the user wants. Each wafer will correspond to the different height of the photoresist to ensure that there is 10  $\mu\text{m}$  of space between the top of the

photoresist layer and the mask. Once the user has spun the photoresist they will place the wafer in the correct wafer holder and slot the cut mask onto the alignment pillars. Then, the photoresist will be burned with the mask and then removed from the device for baking. This process will be repeated for each mask. The overall device is shown in Figure 4.

Hole-Punching Stamp

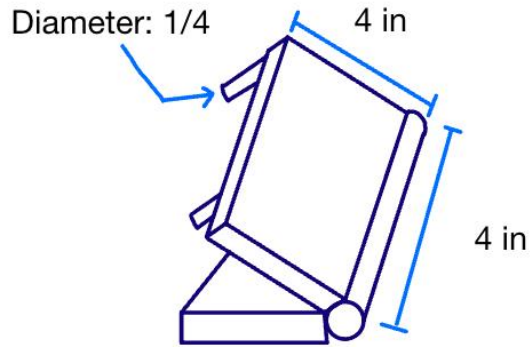

Alignment Pillars

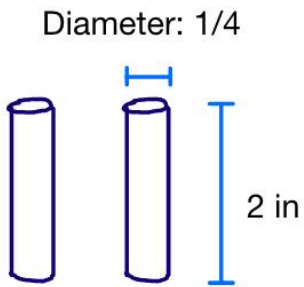

Base: Top Down View

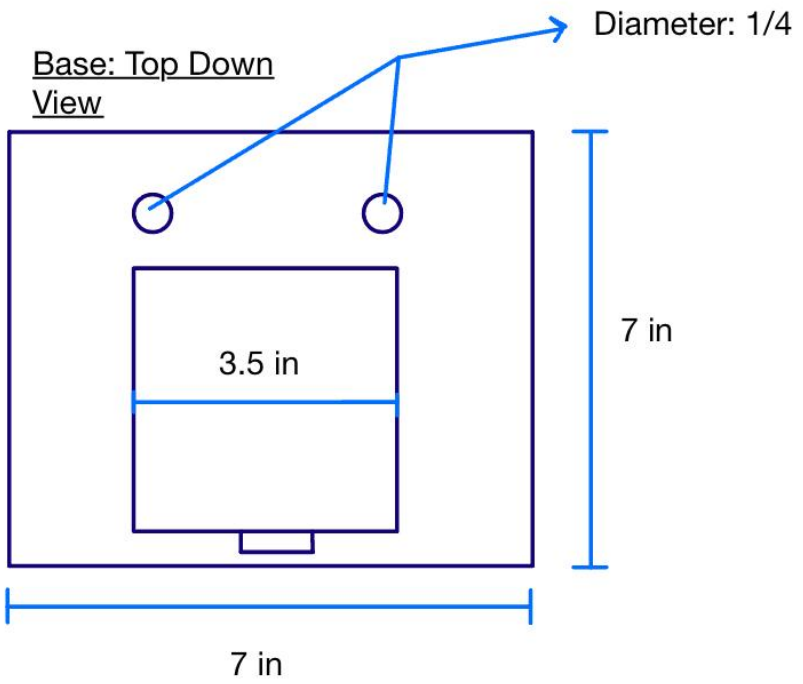

Side View

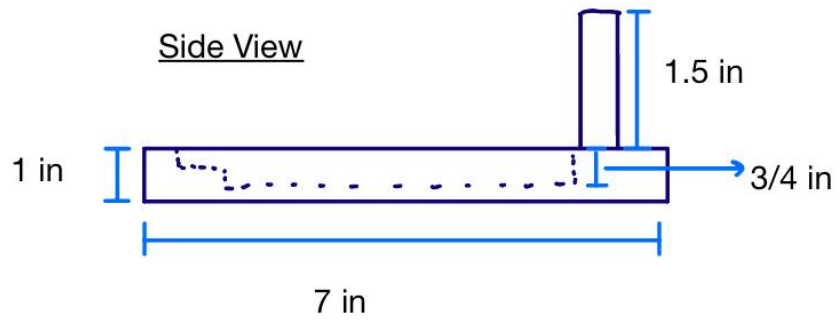

## Wafer Holders: Top Down View

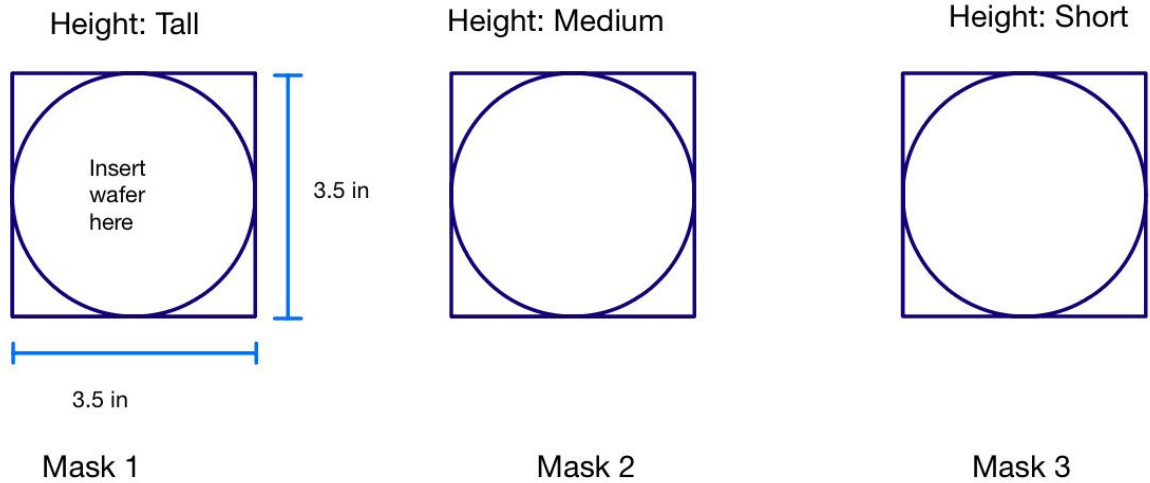

\*Heights are variable

*Figure 4. Divot Design.*

The Divot design is innovative although it is more complicated and may require more skill to use. It may also struggle with achieving the accuracy of 10  $\mu\text{m}$  with the current fabrication tools available. However, if done correctly, it will achieve great accuracy and meet the client's requirements.

## Preliminary Design Evaluation

### Design Matrix

In order to compare the four designs from above, the team used a design matrix with different criteria that are weighted based on their importance to meeting the product design specifications. Each category in the design matrix was selected specifically for this project and given a weight deemed by how important it is to this project's success relative to the other categories. Each design was measured against these categories and their scores are depicted numerically below. Each category is also detailed below and a brief description of the rationale used when ranking each design in each category is provided below as well. The design matrix is shown below in Figure 5.



Current Design Matrix	Weight	Rotating Tower		Laser Cut Alignment Holes		Screw Idea		Divot Design	
		Score	Weighted Score	Score	Weighted Score	Score	Weighted Score	Score	Weighted Score
Accuracy	25	3/5	15	4/5	20	3/5	15	4/5	20
Cost	20	4/5	16	3/5	12	5/5	20	5/5	20
Ease of Use	20	5/5	20	3/5	12	3/5	12	3/5	12
Ease of fabrication	15	3/5	9	3/5	9	4/5	12	4/5	12
Size	10	5/5	10	5/5	10	5/5	10	5/5	10
Durability	10	3/5	8	3/5	6	4/5	8	4/5	8
<b>Total</b>		<b>78</b>		<b>69</b>		<b>77</b>		<b>82</b>	

Figure 5. Design matrix.

**Accuracy (25%):** Accuracy in photomask alignment refers to the precision and correctness with which the patterns on two or more layers of a semiconductor or microfabrication process align or match with each other. The goal of this project is to create a mechanism that can align photomasks in successive trials of photolithography with little error. This involves accurately aligning the photomasks such that the mask patterns are as close to 10  $\mu\text{m}$  precision, with a +100  $\mu\text{m}$  tolerance. Accuracy was given the highest weight of 25/100 due to the fact that the main goal of this project is to develop a method of simple alignment that is highly accurate in the alignment of photomasks for a given substrate.

**Cost (20%):** Cost refers to how much the total expenses in dollars the design will include in this project. Cost was given a weight of 20/100 because of both the history of this project and the real-world struggles with accuracy at far less restrictive budgets. In the past, designers have struggled to create a mechanism that satisfies the client's desired accuracy while complying with a low cost budget. There are some devices that can achieve such desired accuracy, but they cost thousands of dollars usually being either automated, have to utilize built in microscopes, or are some combination of the two. Thus, the budget discrepancy between this project and what is currently produced and manufactured by BioMems companies is what ultimately gives the Cost design criteria such a high weight.

**Ease of use (20%):** Ease of use refers to the ability of the consumer to use the device fully, in a reasonable timeframe, and without unnecessary complexity. A user-friendly system offers

increased efficiency, reduced training time, minimized error rates, cost savings, improved productivity, and greater accessibility. Simplified operations make it easier for users to achieve accurate alignment, reduce production downtime, and maintain a skilled workforce, ultimately enhancing the quality and cost-effectiveness of the microfabrication process and therefore earning ease of use a 20/100 on the design matrix. The divot design ranks the highest in this category as it maintains the best balance of the number of steps in the design process, and is fairly easy to use.

**Ease of Fabrication (15%):** Ease of fabrication refers to how straightforward it is to create or manufacture photomasks used in semiconductor or microfabrication processes. An emphasis on ease of fabrication involves designing photomasks and alignment features in a way that minimizes complexity and reduces the likelihood of errors during the manufacturing process. This can include using well-established manufacturing techniques, clear and intuitive design specifications, and efficient production workflows. Achieving ease of fabrication ensures that photomasks are produced efficiently and accurately, leading to cost savings, reduced production time, and improved overall quality in microfabrication processes. The category of ease of fabrication was given a weight of 15/100 as the device needs to be able to be reproduced for a 6 in. wafer, given that the team is only making this product for a 3 in. wafer. Not only that, but given the small scale elements of this project, the fewer things that require small scale modifications, the better.

**Size (10%):** Size refers to the physical dimensions of the photomasks and alignment features used in semiconductor or microfabrication processes. The size of these components are properly considered as it affects the precision and scale of alignment between different layers or patterns. Smaller features may be used for a 3in wafer alignment, while larger sizes, like for the 6in wafer, may be scaled for different size alignments. The choice of size depends on the specific requirements of the fabrication process and the desired level of precision. Properly managing size in photomask alignment is essential to ensure that the alignment features match the intended patterns and achieve the desired results in the final microfabricated components, thus size earned a relative 10/100 on the design matrix, as it can be scaled and changed accordingly.

**Durability (10%):** Durability refers to the design's ability to withstand wear, stress, and various environmental conditions over an extended period of time while maintaining its functionality and performance. Just like all the other steps, it is important because it ensures the long-term reliability and consistent performance of the device. Since photomask aligners are used in various biomedical and microfabrication applications where precision and repeatability are essential. These devices need to withstand frequent usage and potentially harsh environmental conditions while maintaining precise alignment for accurate microfabrication processes. A durable aligner ensures stable, high-quality results, reducing the need for frequent maintenance

or replacements helping lead to lower cost applications. Thus, the team gave durability a modest 10%, even with this weighted percent, all of the categories in the design matrix are important.

### Proposed Final design

The proposed final design is the Divot design as it scored the highest in cumulative credits. It has good predicted accuracy and cost. However, it is more complicated to use than other designs making it less ideal than the other designs in this department especially considering that it will be used mainly in a teaching lab. It ties with the screw design in ease of fabrication, although none of the 4 design ideas will be particularly easy to fabricate. It also scores the best in size and durability, making it more fitting for use in a teaching lab than the other designs in these categories.

## Fabrication

### Materials

The base holders will be made of plastic from the 3D printer. The base and alignment pillars will be made of acrylic to withstand the UV baking step. The hole-puncher stamp will be made of two commercial hole punchers (steel) and a wooden alignment base.

### Methods

The following steps will be taken to fabricate the divot design:

1. The commercial hole punchers will be attached together at a fixed distance and a fixed depth to ensure that the hole will be punched in the same spot on every mask. This distance and depth will be measured and recorded.
2. Then, the base will be fabricated of acrylic. The holes will be drilled using a lathe at the exact dimensions recorded in step 1. The depth of the base holding hole will be recorded as well as the depth of the alignment pillar holes.
3. Then, the alignment pillars will be made of acrylic. They will be nearly the diameter of the alignment pillar holes in the base. This is so they will be flush with the rest of the design with little opportunity for movement or shifting.
4. Finally, the wafer holders will be made from a solidworks design and sent to a 3D printer. Each wafer holder will have different widths. The first wafer will sit 60  $\mu\text{m}$  below the surface of the base. The second will position the wafer 310  $\mu\text{m}$  below the surface of the base and the third will position the wafer 560  $\mu\text{m}$  below the surface of the base. This is to account for the changing height of the photoresist so that the mask will sit on top of the photoresist perfectly for each layer.
5. Now, the base, the pillars, hole-puncher stamp, and wafer holders have been fabricated separately.

6. To assemble, the pillars will be inserted into the pillar alignment holes in the base and a wafer holder will be inserted into the base hole. This is to make sure that they fit.
7. Finally, testing will be done to test the accuracy and perhaps improve upon the design.

### Final Prototype

The final prototype will consist of the assembled base and pillars, the separate hole-puncher stamp, and the 3 different width base holders. The masks will be slotted into the pillars after being cut with the hole-puncher stamp and aligned together manually with a microscope. The photoresist will then be spun on the wafer. For the first base holder, it will be 10  $\mu\text{m}$  below the surface of the base. This means that the first mask will rest on the base and then be 10  $\mu\text{m}$  away from the photoresist. So, the wafer will be inserted into the first wafer holder and then placed in the base. Then, the first mask will be slotted into the alignment pillars and the first layer of photoresist will be burned. Then, the wafer will be removed from the apparatus and a new layer of photoresist will be spun and the process will be repeated until the photoresist is completed.

### Testing/Future Work

The team plans to split into two groups, one will work on fabricating the hole-punching stamp and the other will focus on creating the base and the wafer holders. The base team will have to make a solidworks design for the wafer holders and then pick an appropriate material for the wafer holders as well. The base team will also work on fabricating the base which will hold the wafer holders, the base will be made of acrylic.

The hole-punching stamp group will work on fabricating the hole-punching stamp. This group will make sure that the holes punched into the masks are identical down to the error allowed. This group will most likely finish their work first and then they will assist the base team and also work on the final deliverables.

Testing will include checking for accuracy between the hole-punching stamp and alignment pillars. Photomasks will be cut using the hole-punching stamp and then inserted and used as intended. Then, a microscope will be used to check the alignment of the final product and its usefulness will be analyzed. This will be repeated 10 times to acquire enough data. If the layers are aligned within 10-100  $\mu\text{m}$  the device will have passed this test.

## Discussion

To expand on the discussion and future workings of this project, the team is going to be re-creating some of the preliminary designs and final design in the same format as the rotating tower, either using a drawing software or solid works. The initial prototype is going to be made using scraps like cardboard and popsicle sticks, representing the future final design. When it comes to design accuracy, the final design will be tested with the client, Dr. Puccinelli,

expanding on his manual alignment technique using the new design. An alignment accuracy of 10-100  $\mu\text{m}$  is expected from the final design. If the requirements are not met the necessary adjustments or improvements will be made to the design and the final design will be altered accordingly. Lastly, one of the main goals of this project is to have the final design be easily replicable. This is due to the photomask aligner being used in the teaching lab and for future student use. After our final design is completed with or without changes, the team plans on creating a replication PDF, more so a “DIY” (do it yourself), so that future students can create their own version of the design for one hundred dollars or less.

## Conclusion

The goal of this project is to design a photomask aligner using biological electrical mechanical microsystems (BioMEMS). In conclusion, BioMEMS play a pivotal role in the investigation of biological interactions, particularly in applications such as cell activity monitoring and biocompatibility testing. This project consists of creating an alignment system that can accurately align photomasks within 100  $\mu\text{m}$ . The overall procedure inherently demands precise alignment of image masks for multiple successive layers, a crucial step in BioMEMS fabrication. While high-fidelity aligners are readily available in the market, their exorbitant cost (tens of thousands of dollars), and impracticality for educational settings have driven the exploration of cost-efficient alternatives [8]. Consequently, the project consisted of three innovative aligner designs that were proposed and rigorously evaluated, leading to the selection of a final design, a fourth and more reliable design, that is both budget-friendly and well-suited for prototyping and testing. The development of these cost-effective aligners not only addresses financial constraints faced by educational institutions but also promotes accessibility and engagement in the field of BioMEMS research, lowering barriers to entry and fostering innovation and progress in the study of biological interactions. These endeavors underscore the collaborative efforts of researchers and educators in driving scientific advancements forward and making cutting-edge technologies more accessible.

## References

- [1] Mask alignment systems, <https://www.evgroup.com/products/lithography/mask-alignment-systems> (accessed Oct. 27, 2023).
- [2] T. James, M. Mannoor, and D. Ivanov, “BioMEMS –Advancing the Frontiers of Medicine,” *Sensors*, vol. 8, no. 9, pp. 6077–6107, Sep. 2008, doi: <https://doi.org/10.3390/s8096077>.
- [3] “OmniCure® S1500 UV Spot Curing System.” Accessed: Nov. 01, 2023. [Online]. Available: <https://sharedlab.bme.wisc.edu/labs/1002/equipment/microfab/OmniCure-S1500-Brochure.pdf>

[4] "Model P-6708D 8" Desk-Top Precision Spin Coating System Operator's Manual." Accessed: Nov. 01, 2023. [Online]. Available:

<https://sharedlab.bme.wisc.edu/labs/1002/equipment/microfab/spin-coater-scs6708.pdf>

[5] B. Department, "BME Shared Lab Resources," BME Lab - 1002 ECB - Biomedical Experimental Teaching Lab, <https://sharedlab.bme.wisc.edu/labs/1002/> (accessed Nov. 1, 2023).

[6] UW Makerspace, <https://making.engr.wisc.edu/> (accessed Nov. 1, 2023).

[7] Safety Data Sheet according to 1907/2006/EC, Article 31,

[https://kayakuam.com/wp-content/uploads/2019/08/SDS\\_SU-8-Series-Resists\\_-\\_EU.pdf](https://kayakuam.com/wp-content/uploads/2019/08/SDS_SU-8-Series-Resists_-_EU.pdf) (accessed Oct. 11, 2023).

[8] S. Cargou, "Introduction about photomask in Microfluidics," Elveflow,

<https://www.elflow.com/microfluidic-reviews/soft-lithography-microfabrication/introduction-about-photomask-in-microfluidic/> (accessed Nov. 1, 2023).

# Appendix

## A. PDS

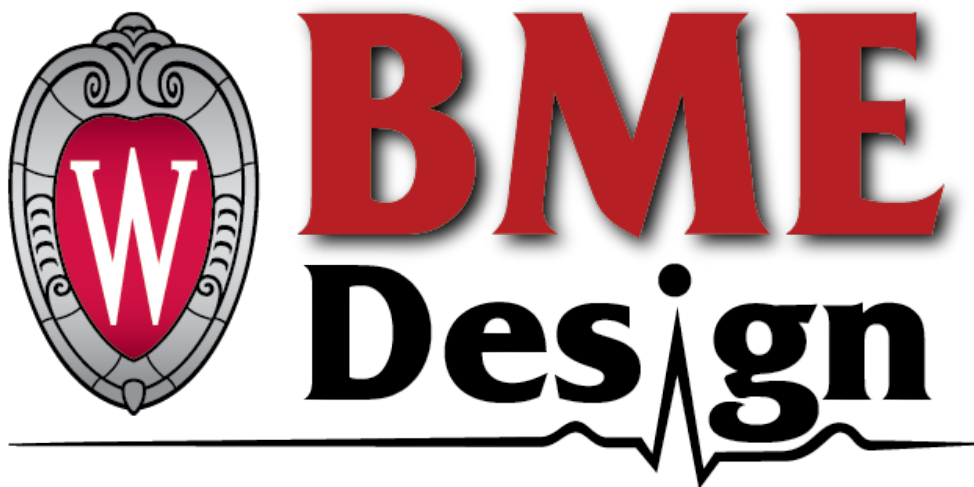

## LOW-COST BIOMEMS PHOTOMASK ALIGNER

---

PRELIMINARY PRODUCT DESIGN SPECIFICATIONS

*BME 200/300*

*Lab Section #: 303*

Team Members:

Jayson O'Halloran, Co-Team Leader

Emily Stoebe, Co-Team Leader

Luke Waldhuetter, Communicator

Saketh Peddireddy, BSAC

George Moran, BPAG  
Paulie Reuteman, BWIG

October 7th, 2023

**Function :**

The low cost BioMEMS photomask aligner is a device that is meant to align photomasks relative to each other so that when used in photolithography applications, separately spun photoresist layers are properly aligned for a multitude of uses such as individual cell culture. The photomask aligner must be extremely accurate down to micro-measurements in order to complete this goal.

**Client requirements:**

- The photomask aligner must be accurate under 100  $\mu\text{m}$  but preferably within 10  $\mu\text{m}$  in accuracy
- The aligner should be able to be held 12  $\mu\text{m}$  above the photoresist layers to ensure the pattern is burned into the photoresist accurately
- The aligner should be resistant to the baking step of the photolithography process

**Design requirements:**

1. Physical and Operational Characteristics

a. *Performance requirements:*

The photomask aligner should be able to hold the base plate and the subsequent photoresist layers in such a way that the sequence of photomasks are all aligned within 100  $\mu\text{m}$  of each other. Preferably, the photomasks will be aligned within 10  $\mu\text{m}$  of each other, however, 100  $\mu\text{m}$  is the stronger requirement. The aligner should also be able to hold the photomasks about 12  $\mu\text{m}$  above the photoresist layers so that the patterns can be accurately burned into each photoresist layer. Finally, the entire device should be resistant to temperatures of 90-110C [1] to be resistant to the baking step of the photolithography process.

b. *Safety:*

The aligner is meant to be used in a teaching lab so it must be extremely safe to use. It must not melt under the aforementioned 90-110C to prevent potential



damage to other items in the lab. It also must not conduct heat easily, to prevent burns to the users. It should be able to remain under 52C [2] at all times even during the baking step. Naturally, it should have limited sharp edges or pointy parts to ensure minimized cuts and other physical damage. The aligner should also have a strong center of gravity and be under 2 pounds [3] to prevent potential harm due to falling or dropping.

c. *Accuracy and Reliability:*

The aligner should be accurate to 100  $\mu\text{m}$  but preferably accurate down to 10  $\mu\text{m}$ . The aligner should also be able to hold the photomasks about 12  $\mu\text{m}$  above each layer. The aligner should be able to repeat the layer making process nearly exactly between all uses. This means that the aligner should be accurate down to 5  $\mu\text{m}$  between runs. However, as long as the aligner works as intended for each individual run, it will serve its purpose.

d. *Life in Service:*

The photomask aligner must consistently maintain similar conditions throughout the duration of usage. Since the aligner has to layer masks over each other to a difference of 10  $\mu\text{m}$ , the photomask aligner must be able to accurately layer masks 5 times to complete tests. The time it takes the photomask aligner to align two to three masks (at most four) will take approximately fifteen minutes. The fifteen minutes includes time it takes to align, bake, and run the UV light process.

e. *Shelf Life:*

It is estimated that the product should last more than ten years [4]. Since the photomask aligner will be made out of material similar to Plexiglass, it will be able to withstand temperatures as low as -40C and as high as 200C . However, room temperature storage is ideal.

f. *Operating Environment:*

The aligner is designed to operate within a teaching environment meaning it must be relatively easy to use. It also must be able to withstand 90-110C during the baking stage of the photolithography as stated previously. Sterilization is not a priority for this device and it will not require a clean room to operate. However, this device will likely be used under a fume hood due to the SU-8 solvent that will be applied to the wafers during the photolithography process [5].

g. *Ergonomics:*

The ergonomics of the photomask aligner must allow the photomasks to be placed into the aligner and adjusted relatively easily. It also is critical that the photomasks are able to be aligned extremely accurately. The aligner will have a feature that allows the user to swivel the mask out of the way to allow the user to bake the wafers without them leaving the aligner. Another critical consideration is the ability of the aligner to maintain alignment throughout the photolithography process to ensure a properly aligned product.

h. *Size:*

The photomask aligner is designed to fit varying wafer diameters and thicknesses. The typical sizes are 3, 4, and 6 inches. The thickness of the wafers ranges but this does not affect the alignment of the photomasks. The size of the aligner is not a critical factor. The only requirement is that it will fit under a fume hood. It does not need to be moved.

i. *Weight:*

Acrylic is a lightweight material, which will be used for the aligner. No weight specification was provided, but an estimate of about under 2 pounds for the aligner is a good gauge of what it should be, as it needs to have a strong center of gravity and be able to prevent damage from falls or chips [3].

j. *Materials:*

Both acrylic and polycarbonate were in consideration for the photomask aligner. Both are lightweight materials that will be able to withstand the temperature range it needs to, while staying under 2 pounds as stated before. Acrylic is more likely to shatter while polycarbonate is more likely to get scratches [6]. Acrylic is also cheaper than polycarbonate, which is big considering the budget of \$100. Ultimately, acrylic is the final decision, as scratches would not be good to have for a device that needs to be transparent, and acrylic is much cheaper [7].

k. *Aesthetics, Appearance, and Finish:*

The aesthetic and appearance of the photomask aligner, due to the acrylic material, will be a glossy, polished finish. The appearance will be a small device with three circles that are adjustable in height. It will most likely be the same color throughout and whatever color the client.

## 2. Production Characteristics

a. *Quantity:*

Only one alignment mechanism needs to be produced. This alignment mechanism will consist of one rod with three attached mask holders.

b. *Target Product Cost:*

The components needed to construct this mask aligner are the mask holders, the rod to which they are attached, and a means of attaching them. Acrylic is resistant to photolithography so acrylic mask holders, an acrylic rod, and acrylic glue will be used. The acrylic mask holders should cost about \$5 [8] a piece, giving a total sum of \$15. The acrylic rod will cost about \$3.63 [9], and the acrylic glue will cost \$10 [10]. None of these prices account for tax or shipping costs, so an additional \$5 is added for confidence. Additionally, the acrylic rod and acrylic photomask holders will need to be modified, but that should come free of cost at one of the provided labs. Thus, the total cost to construct the photomask aligner should be around \$35.

### 3. Miscellaneous

a. *Standards and Specifications:*

The photomask aligner is not classified by the FDA because it is not a device intended for clinical use or diagnostic purposes, rather it is used in research and laboratory settings. While there are no specific ASTM standards for this project, all individuals interested in using this device should have an understanding of photomask alignment prior to use of the aligner. This is due to the aligner being used for various techniques such as cell cultures, biochemical assays, mask mold alignment, etc.

b. *Customer:*

The customer is requesting the production of a Low-Cost BioMEMS Photomask Aligner that can provide accuracy between 10 and 100  $\mu\text{m}$  during mask alignment, ideally closer to the 10  $\mu\text{m}$  range. Currently the client creates photomasks in a CAD program, creating alignment marks on each mask [11]. The amount, location, and shape of the alignment marks varies based on preference. As expected with photomask alignment by hand and eye coordination, the resolution is to be around 200-300 $\mu\text{m}$  of accuracy at the very best, which is three to twenty times the scale than what is done with the traditional photomask aligner device.

c. *Patient-related concerns:*

Currently, there are no patient-related concerns when it comes to the usage of photomask aligners.

d. *Competition:*

There are existing means of aligning photomasks for comparable research and experimental practices. However, many are quite expensive; the cheapest manual mask aligner sells for under, but in the range of, \$7,500 [12], and automated mask aligners sell for even more.

**References:**

- [1] AllAdmin, “8. What is the function of the soft bake of photoresist films after the coating?,” Allresist EN, Aug. 14, 2008.  
<https://www.allresist.com/resist-wiki-what-is-the-function-of-the-softbake-of-photoresist-films-after-the-coating/> (accessed Oct. 07, 2023).
- [2] B. E. Pichoff, M. Schydlower, and S. R. Stephenson, “Children at risk for accidental burns from hot tap water,” *Texas Medicine*, vol. 90, no. 11, pp. 54–58, Nov. 1994,  
Available:  
<https://pubmed.ncbi.nlm.nih.gov/7997963/#:~:text=Studies%20show%20that%20a%20temperature>
- [3] “Broken Foot Basics,” WebMD. <https://www.webmd.com/a-to-z-guides/broken-foot>
- [4] R. GmbH, “Temperature behavior,” PLEXIGLAS® | EN,  
<https://www.plexiglas.de/en/temperature-behavior#:~:text=It%20can%20withstand%20temperatures%20as,the%20material%20start%20to%20fuse.> (accessed Oct. 10, 2023).
- [5] Safety Data Sheet according to 1907/2006/EC, Article 31,  
[https://kayakuam.com/wp-content/uploads/2019/08/SDS\\_SU-8-Series-Resists\\_-\\_EU.pdf](https://kayakuam.com/wp-content/uploads/2019/08/SDS_SU-8-Series-Resists_-_EU.pdf)  
(accessed Oct. 11, 2023).
- [6] “Acrylic vs. Polycarbonate - Regal Plastics,” [www.regal-plastics.com](http://www.regal-plastics.com).  
<https://www.regal-plastics.com/blog/acrylicvspolycarbonate/#:~:text=Acrylic%20plastic%20is%20a%20lightweight>
- [7] “Polycarbonate vs Acrylic - Learn about the Difference Between Acrylic & Polycarbonate Material | A&C Plastics,” [www.acplasticsinc.com](http://www.acplasticsinc.com).

<https://www.acplasticsinc.com/informationcenter/r/acrylic-vs-polycarbonate#:~:text=Polycarbonate%20is%20sometimes%20called%20Lexan> (accessed Oct. 11, 2023).

[8] Amazon, "Amazon.com: Tong Gu 1X 1/5 inch Thick Acrylic Plexiglass Glass Sheet Color Transparent for Home Decor DIY... (3.9x3.9 inch/10x10 cm, Transparent) : Industrial & Scientific," *www.amazon.com*. <https://a.co/d/9m6q5zI> (accessed Oct. 10, 2023).

[9] ePlastics, "0.250" Diameter Clear Extruded Acrylic Rod at ePlastics," *www.eplastics.com*.  
[https://www.eplastics.com/ACREXR0-250?gad\\_source=1&gclid=Cj0KCQjw7JOpBhCfARIsAL3bobeyQzHHtTiLKCFGtQex4JWtjAc0hEF0-ZPLN3d8\\_6TPEqhKg53utJkaAvlNEALw\\_wcB](https://www.eplastics.com/ACREXR0-250?gad_source=1&gclid=Cj0KCQjw7JOpBhCfARIsAL3bobeyQzHHtTiLKCFGtQex4JWtjAc0hEF0-ZPLN3d8_6TPEqhKg53utJkaAvlNEALw_wcB) (accessed Oct. 10, 2023).

[10] Amazon, "Glass Glue, 30g Clear Waterproof Acrylic Glue, Glass to Glass Glue for Bonding Glass and Other Materials, Super Instant Glue for Glass, Acrylic, Mirror: Amazon.com: Industrial & Scientific," *www.amazon.com*. <https://a.co/d/aVHDuU7> (accessed Oct. 10, 2023).

[11] R. Comer, P. Fossum, N. Retzlaff, and W. Zuleger, "BME Design Projects Better Health By Design," BioMEMS photomask aligner, [https://bmedesign.engr.wisc.edu/projects/f11/photomask\\_aligner](https://bmedesign.engr.wisc.edu/projects/f11/photomask_aligner) (accessed Oct. 10, 2023).

[12] Q. L. Pham, A. Tong, A. Mathew, S. Basuray, and R. S. Voronov, "A compact low-cost low-maintenance open architecture mask aligner for fabrication of multilayer microfluidics devices," *Biomicrofluidics*, vol. 12, no. 4, Jul. 2018, doi: <https://doi.org/10.1063/1.5035282>.