



DEPARTMENT OF  
**Biomedical Engineering**  
UNIVERSITY OF WISCONSIN-MADISON

# LOW-INTERFERENCE WHEELCHAIR FOOTREST

BME 200/300 - Final Report

**Client:** Mr. Dan Dorszynski

**Advisor:** Prof. William Murphy

**Team Members:**

Lael Warren	300	Team Leader
Liv Baumann	300	Team Leader/ BSAC
Amanda Kothe	200	Communicator
Sadie Rowe	200	BWIG
Gracie Hastreiter	200	BWIG
Juliana Dugo	200	BPAG

# Abstract

Worldwide, millions of people use wheelchairs as assistive devices. There are many aspects of wheelchairs that can be altered to cater to users with different needs, however there are not many options of footrests that could cater to users with varying leg mobility. Currently, the majority of wheelchair footrests on the market support the user's legs to a degree that prevents leg movement or access to the ground. While this level of stability is helpful for many users, it also creates a demand for wheelchair footrest that allow more leg movement for users with greater leg mobility. Additionally, existing footrests often permanently attach to the wheelchair or are removable but bulky and heavy. The team has been tasked with creating a footrest that allows for more leg movement than footrests currently on the market. The footrest must be lightweight and removable or easily stored on the wheelchair. In order to solve this problem, the team creates a removable folding footrest. The footrest consists of a castor cap that attaches to the wheelchair base, an aluminum footplate, and a hinge to connect the footplate to the castor cap. The footplate is able to be stored on the wheelchair when folded upwards 90 degrees, allowing for access to the ground. In order to ensure the team is providing the client with a sufficient device, the footrest is tested and evaluated on various criteria. If any design specifications are not met, possible future modifications will be discussed.

# Table of Contents

<b>Abstract</b>	<b>2</b>
<b>I. Introduction</b>	<b>4</b>
Motivation	4
Existing Devices and Current Methods	4
Problem Statement	5
<b>II. Background</b>	<b>5</b>
Relevant Biology and Physiology	5
Client Information	6
Design Specifications	6
<b>III. Preliminary Designs</b>	<b>7</b>
Fold-Up Footrest	7
Folding Mesh Footrest	8
Airplane Armrest Footrest	9
<b>IV. Preliminary Design Evaluation</b>	<b>10</b>
Design Matrix	10
Proposed Final Design	12
<b>V. Fabrication/Development Process</b>	<b>13</b>
Materials	13
Methods	13
Final Prototype	14
Testing	17
<b>VI. Results</b>	<b>18</b>
<b>VII. Discussion</b>	<b>21</b>
<b>VIII. Conclusions</b>	<b>22</b>
<b>IX. References</b>	<b>24</b>
<b>X. Appendix</b>	<b>26</b>
A. Product Design Specification (PDS)	26
B. Expenses and Purchases	30
C. Testing Protocols	30

# I. Introduction

## Motivation

Wheelchairs are one of the most common assistive devices worldwide, with approximately 131 million people worldwide reporting using a wheelchair [1]. Many wheelchairs in today's society are able to be customized to fit the users needs; with adjustments able to be made to the frames, controls, cushions, and head arrays [2]. Another customizable aspect of wheelchairs includes the footrests, which traditionally consist of a bar that connects foot plates to the base of the wheelchair seat. Footrests are vital to maintain stability, comfort and safety of wheelchair users. If a desired footrest can not be achieved or maintained, the patient may be negatively affected [3]. Current wheelchair models do not account for varying levels of mobility among patients, with many being difficult to remove when not in use or too heavy to use [4]. Ideally a wheelchair footrest should be able to adapt to a person's mobility and range of motion, while still being durable, lightweight, and easy to use.

## Existing Devices and Current Methods

While there are many different types of wheelchairs on the market, there are two major categories of foot support. The most common category is a footrest. A wheelchair footrest generally consists of a footrest hanger and footplate. Footrest hangers attach to either side of the seat and are often made of aluminum alloys or other lightweight but durable materials. Additionally, the footrest hanger is often designed to be adjustable in order to accommodate different leg lengths among wheelchair users. The footplate is a small plastic or metal piece fixed at a 90° to the end of the footrest hanger. Footplates are often made to swing-away, in line with the footrest hanger, in order to make transitions in and out of the wheelchair less cumbersome. There are several different types of footplates on the market, including individual standard footplates and rigid wheelchair footrests. Standard footplates consist of two separate components designed to rest both feet separately while rigid wheelchair footrests consist of a single platform designed for both feet to rest beside each other [5]. The other type of foot support available are legrests. Legrests are not as widespread as footrests and are most common on tilting wheelchairs where they are able to move with the chair to provide leg support in both seated and reclining positions. Legrests generally consist of the same components as a footrest with the addition of a calf-support pad perpendicular to the footrest hanger [6]. Due to its additional components, legrests are often heavy and bulky, making them less than ideal for users with limited mobility who require a lightweight design. It is also difficult to set the footplate to a comfortable position when the leg rest is adjusted. [7].

There are many wheelchair footrests and leg rests on the market currently. Both Drive Medical [8] and Invacare Corporation [9] offer traditional wheelchair footrest designs with a removable footrest hanger and footplate. In addition, the Drive Medical model includes a heel strap for increased foot support. The inclusion of a foot strap on footplates adds significant support without the addition of substantial weight and may be ideal for users who reposition often. The footplates for both of these designs are 7" x 6" and swing upwards 90° to create foot space when needed. Both Drive Medical [8] and Invacare Corporations [9] also offer legrest designs which feature calf pads. These calf pads are fixed rigidly on the footrest hanger and may not be adjusted, but the length of the hangers themselves can be altered accordingly. Most wheelchair companies offer a variety of footrests designed specifically for their type of chair, but a majority of designs model closely to the ones described above. Prices for wheelchair foot supports generally start at \$40 and range upwards of \$300, with some exceptions [10].

Existing designs include large and bulky components which might be difficult for users with mobility issues to attach and remove independently. If a new wheelchair footrest can be designed that allows for a greater accessibility, gives users increased range of motion, and maximized ease of use while still being lightweight and cost effective, wheelchair users would be allowed increased independence in their daily lives.

## Problem Statement

There are currently no wheelchairs on the market which allows those who are not paralyzed to perform helpful movements, such as opening doors with their feet or being able to pick up objects from the floor. In addition, current footrest models are heavy, bulky, and not easily able to be removed and stored when not in use. While footrests are crucial for support if the wheelchair tilts or reclines, it is imperative to design a wheelchair footrest that allows for more foot mobility- should the user require it- and for easier storage of said footrests. The updated footrests should be able to adapt to a person's abilities, should be easily able to remove and store them when not in use, and be lighter and less bulky, while still providing the benefits of a footrest when necessary.

## II. Background

### Relevant Biology and Physiology

There are many different conditions that require the use of wheelchairs; including quadriplegia, paraplegia, cerebral palsy, and various neuromuscular disorders. All of these conditions result in different

levels of mobility, strength, and range of motion [3]. It is estimated that 1.85% of the world population, or roughly 131,000,000 people, have a physical disability which requires use of a wheelchair [1]. The broad goal of this project is to design footrests that are able to adapt to differing levels of mobility in wheelchair users worldwide.

Proper leg and foot support is immensely important to the comfort of wheelchair users as long term use of improper foot or leg rests can lead to lower back pain and excess pressure on the user's thighs and buttocks area. Wheelchair footrests also offer posture support and play a significant role in supporting appropriate pelvic and lower limb positioning. Proper posture should compliment the natural 'S' shape curve of one's spine and is maintained when weight is distributed equally across both hips and both feet are flat on a solid surface [11]. The support of footrests on wheelchairs allows for proper seated positioning which contributes to an equal distribution of weight below the torso, increased blood flow, and eased pressure in the legs, hip joints, muscles, and lower back regions [12].

Proper footrest position is also important in order to prevent accidental injury. A study done by San Francisco State University's School of Engineering investigated the types of injuries sustained by wheelchair users over a 5 year period. In the 253 incidents over the 5 year period, 33 % were component failures, which included faulty footrests. In addition, 42% were tips and falls, which included footrests mishaps. Reported injury types included cuts and bruises, fractures, head injuries, muscle and tendon injuries, and 13 unspecified injuries. Results from the experiment show correlation with powered wheelchairs and sideways falls [3].

## Client Information

The client, Mr. Dan Dorszynski, is a resident of the Madison, Wisconsin area who is looking for improvements to his wheelchair's footrest design. He requires the team to manufacture a footrest that allows him more mobility and also is easier to handle when not in use.

## Design Specifications

This design is built specifically for our client, but there is potential for an expanded customer base for those in wheelchairs with foot mobility. The client's requirements include the footrest having the ability to be stored on the wheelchair itself or be easily removable from the wheelchair, have a combined weight of 3-4 lbs, and the ability to move vertically with the wheelchair. The footrest should have an equivalent lifespan of a typical wheelchair base (4-5 years) [13]. Additionally, the wheelchair should support the heel of the client's foot with a lip or ledge the heel can rest against in order to maintain a positioning, and prevent the heel from sliding off the back of the footplate, that will ensure the safety and

comfort of the client's foot. The device should be able to support the force of the clients feet, or 149.60 N [14], when in use. The footrest must be removable in order to not hinder the user's transfer onto or off of the wheelchair. The footrest must be able to be easily removed and attached onto the wheelchair. The footplates should be able to fold down to 0 degrees, and be parallel with the floor in order for the user to be able to rest on top of the footplate. Additionally, the footrest should allow for the client to easily flip the footrest between the upward storage position and the folded down position. The footrest should also be able to fold up 90 degrees in order to not interfere with any leg or foot movements the client wishes to perform. Finally, due to the weather and terrain in Wisconsin, the footrest must be able to operate both indoors and outdoors; specifically, they should withstand a temperature range of 14-80 °F [18], be waterproof, and have a ground clearance of at least 3 inches to avoid causing obstruction with the wheels and floor.

### **III. Preliminary Designs**

#### **Fold-Up Footrest**

The Fold-Up Footrest footrest design consists of two separate footrest pieces that will support one foot each. The footrest pieces attach to the right and left castors on the base of the wheelchair. An attachment device secures the footrest to the castors. The attachment devices are molded to fit tightly around the top of the castors and strap around the bottom of the castors to ensure the stability of the footrest. A hinge connects the attachment device to the footplate portion of the design. The hinge locks at 90 degrees, which ensures the footplate will remain parallel to the ground while in use. When the footrest is not in use, the footplates are able to fold back up 90 degrees to be stored next to the castors. This allows the client to remove the footrest and easily store it on the wheelchair while the wheelchair is in use.

The design features two separate footrest pieces to ensure that the client is able to easily fold up the footrests when not in use. Because the footrests do not take up the entire space between castors, the client is able to move his foot off the footrest and out of the way to allow enough room for the footrest to fold up. Additionally, the footrest attaches to the base of the wheelchair which allows the client to utilize the up and down movement of the wheelchair seat to get their feet on and off of the footrests. The compact design of the foot plate allows the footrest to be stored next to the castors without interfering with the wheelchair components, the movement of the client, or the client's transfer on and off the wheelchair.



**Figure 1:** *Fold-Up Footrest Design Drawing*

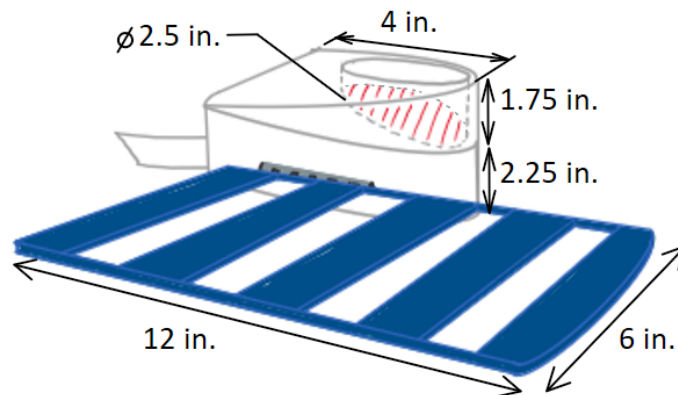

**Figure 2:** *Fold-Up Footrest Design Dimensions*

## Folding Mesh Footrest

The Folding Mesh Footrest design consists of one foot piece that will support both feet. The frame of this footrest is made from a metal material and the footplate is made from a mesh material. The back portion of the footrest attaches to the base of the wheelchair. The foot piece portion connects to the back section of the footrest by hinges. The hinges lock at 90 degrees, ensuring the foot piece will only fold down 90 degrees to remain parallel with the ground when in use. When not in use, the foot plate folds back up 90 degrees and stores on the base of the wheelchair, behind the client's legs.

This design also attaches to the base of the wheelchair. Again, this allows the client to utilize the movement of the wheelchair seat to get their feet on and off of the footrests. The footrest is made from a



mesh material to ensure the footrest is lightweight and compact and allows for storage on the wheelchair. Additionally, the footrest is able to be completely removed from the wheelchair base. The client is then able to remove the mesh portion from the frame if they wish to clean it.

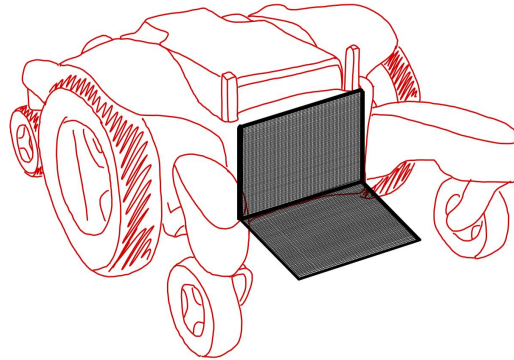

**Figure 3:** *Folding Mesh Footrest Design Drawing*

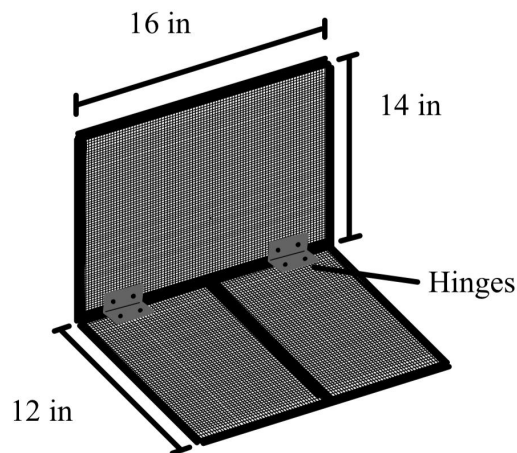

**Figure 4:** *Folding Mesh Footrest Design Dimensions*

## Airplane Armrest Footrest

The Airplane Armrest Footrest is stored underneath the armrest and flips around to fold down and to the side when in use, similar movement to an airplane tray table. The storage box is made from a plastic material and the footrest components are made from a plastic material with metal supports. This ensures that the footrest is strong enough to support the client's feet but also light enough that our client is able to fold the footrest down and back up into the storage box. When not in use, the footrest folds back up and is stored in the storage box that is located on the right side of the wheelchair. The client transfers

on and off the wheelchair from the left, so installing the storage box on the right side of the wheelchair ensures the footrest will not restrict the client's transfers.

The seat of the client's wheelchair is able to move up and down as well as tilt back and forward. This design attaches to the seat of the wheelchair, so it will move up and down and tilt with the seat. This ensures that the client's feet will be supported by the armrest no matter the position the seat is in.

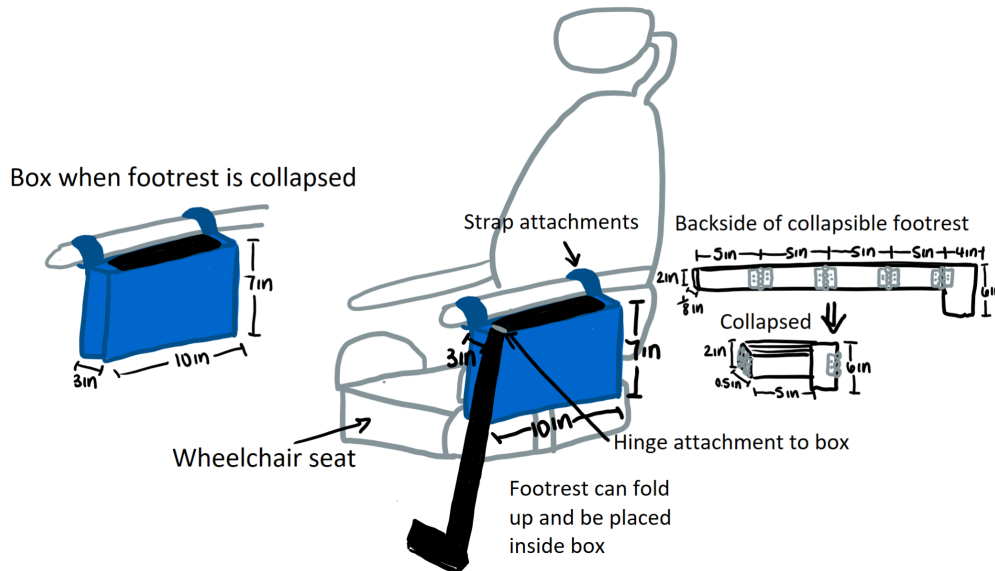

Figure 5: Airplane Armrest Footrest Design Drawing

## IV. Preliminary Design Evaluation

### Design Matrix

The design matrix is a tool employed by the design team to evaluate preliminary designs in terms of important selected criteria. The criteria chosen by the design team was evaluated based on the client's requirements, what was most readily accomplishable in a semester, and by the amount of background knowledge that the design team has.

The criteria includes 7 categories, where each category has a specific percentage in which they contribute to the total point system. First category is ease of use, weighted 25 percent which is the highest. Ease of use is extremely important since the design needs to be easy and simple to function for the client since they have limited mobility. Next is storage, weighted 20%. This category assesses how well the design is able to be low interference. The ideal design needs to be stored discreetly on the wheelchair, so it can be spatially low interference. The storage aspect must also not interfere with the other

functionalities of the wheelchair. Next is weight, weighted 15%. A lightweight footrest design is lacking in competing designs. The weight category assesses how well the design satisfies the outlined maximum weight of 4 pounds, to accommodate the clients needs. Next is size, weighted 10%. Size has a similar assessment to storage. This category assesses if the design has a good balance between being small enough to be low interference spatially, and an appropriate size to fit the client's feet. Next ease of fabrication, weighted 10%, assesses how easy the design is to fabricate. Next durability, weighted 10%, assesses how well the design can withstand day to day usage and potential weather elements. The footrest is desired to have the same lifespan as the wheelchair, which is about 5 years. Finally cost comes in last, weighted 5%, which assesses how expensive the design is. Higher the scores reflect a less expensive cost. This category is rated lower since the client's needs come first.

The matrix results applied the discussed criteria. For ease of use, The Fold-Up Footrest design and Folding Mesh Footrest scored full points since both have simple operations of flipping up 90 degrees for the optimal storage position. The storage category awarded full points to the Fold-Up Footrest since it proves to maximize low interference and does not crowd the front area or other functions of the wheelchair. The weight category awarded full points to the Folding Mesh Footrest since the footplate being made of mesh fabric will be extremely lightweight. The ease of fabrication category awarded full points to the Folding Mesh Footrest since it does not require complex mechanical procedures. The durability category awarded full points to the Fold-Up Footrest, since the sturdy foot plates made of either plastic or aluminum and hinge reinforcements, will withstand constant forces and weather. Finally cost awarded full points to the Folding Mesh Footrest since the use of mesh fabric minimizes the cost of the entire design.

**Table 1:** *Design Matrix. Evaluation of feasible design ideas amongst different criteria. Highlighted areas indicate the highest score per category. Scores out of 5.*

	Design 1: Fold-Up Footrest	Design 2: Folding Mesh Footrest	Design 3: Airplane Armrest
Ease of use (25)	5/5	5/5	2/5
Storage (20)	5/5	4/5	3/5
Weight (15)	4/5	5/5	2/5
Size (15)	5/5	5/5	3/5
Ease of Fabrication (10)	4/5	5/5	1/5
Durability (10)	5/5	3/5	3/5
Cost (5)	3/5	5/5	2/5
Total (100)	93	92	47

## Proposed Final Design

According to the design matrix, the team decided to move forward with a modified version of Design 1: The 'Fold-up Footrest'. In particular, its simple design allows for the most ease of use and greater potential for the use of lightweight durable materials. Several aspects of the design allow for the best storage capabilities. The fold-up aspect allows the device to be out of the way when not in use, but remain on the wheelchair. This eliminates the need for the user to do excess work. The design is also relatively confined to the castor region of the wheelchair and is therefore not a large hindrance to other wheelchair functions, both when in use and not in use. Compared to other designs, this one is slightly more difficult to manufacture. The modified design requires either a mold or a complete model of the castor in order to adequately create a casing to fit around them. However, the stability the design offers as a result outweighs this disadvantage, and the process for manufacturing this is nonetheless achievable. Design 2 did offer very similar advantages and was lower in cost, but its durability and storage disadvantages outweigh the disadvantages of Design 1. Design 3 did not perform high in any category.

# V. Fabrication/Development Process

## Materials

For the fabricated footplate, the team chose the aluminum alloy 6601-T6 because its properties outcompeted alternative materials when considering design specifications. AA6601-T6 allows for design flexibility as it is easy to cut and sand, making fabrication simple. The main benefit of this material is its high strength-to-weight ratio, meaning that weight reduction won't compromise the structure's integrity. The density of the alloy is  $2.70 \text{ g/cm}^3$  [15] and it is highly strong and durable, with capability of withstanding a stress of 276 MPa [15]. For our project specifications which pertain to the cross sectional area and weight of our clients legs, a compressive stress of 2921.54 Pa will be applied. This applied stress equates to a factor of safety of 94488. The material chosen is also corrosion resistant [16], will not deteriorate when in contact with water, and will remain stable at the temperature ranges 14-80 °F as stated in our design specifications, therefore reliable in a wide variety of weather conditions. This meets the lifespan design specification in which the designed footplate must have a longevity equivalent to that of the wheelchair: approximately 5 years [2].

For the 3D printed castor cap, the team opted to utilize tough PLA. This plastic option is low in cost and strong in durability. Tough PLA is less brittle than regular PLA and has a yield stress of 47.5 MPa [17] in the vertical direction, meaning it will not undergo plastic deformation if our anticipated load of 2921.54 Pa is applied. It costs \$0.08 per gram, making it reasonable within our budget. Additionally, tough PLA should not be exposed to temperatures greater than 136.4 °F [17], and is non porous and waterproof, therefore it fits within our weather resistance requirements.

## Methods

We initiated the fabrication process using a 12 by 12 inch sheet of aluminum alloy 6061-T6, with a thickness of  $\frac{1}{8}$ , and using a bandsaw, to divide the sheet into four 6 by 6 inch squares in the Team Lab. Subsequently, we rounded the edges using a vertical belt sander and refined the surface with handheld files. To meet weather conditions and functional criteria, we drilled 9 equidistant holes, forming a 2-inch spaced grid. We used a 0.334-inch diameter drill bit on a drilling machine at the recommended speed of 850 RPM based on our thickness, with cutting oil to reduce friction and prolong the life of both the drill bit and our material. This meticulous hole arrangement facilitates drainage of water or snow. After cleaning off the oil residue, our aluminum footplate was ready for integration.

In tandem, our 3D-printed caster cap was designed via SolidWorks, and printed using tough PLA. After printing, it was verified that the cap was compatible, and the holes lined up. The subsequent step involved modifying the aluminum plate to accommodate the 100-degree hinge. Markings and a calibrator guided the removal of a rectangular section using a bandsaw, and handheld files were used for finishing. We used M4 x 0.7 x 12 mm screws to screw the hinge into place onto the aluminum plate. Drilling was done using the drill press machine at 850 RPM and manual threading tools were then employed. The hinge was secured using screws, a 9/32" nut, and a torque wrench. Drilling and threading into the 3D-printed cap followed the same process, except a handheld drill was used. Finally, Velcro straps were employed to fasten the assembled components onto the castors, completing our comprehensive fabrication process for our final design as illustrated in Figure 8.

## Final Prototype



**Figure 5:** 6" x 6" *Aluminum Footplate*

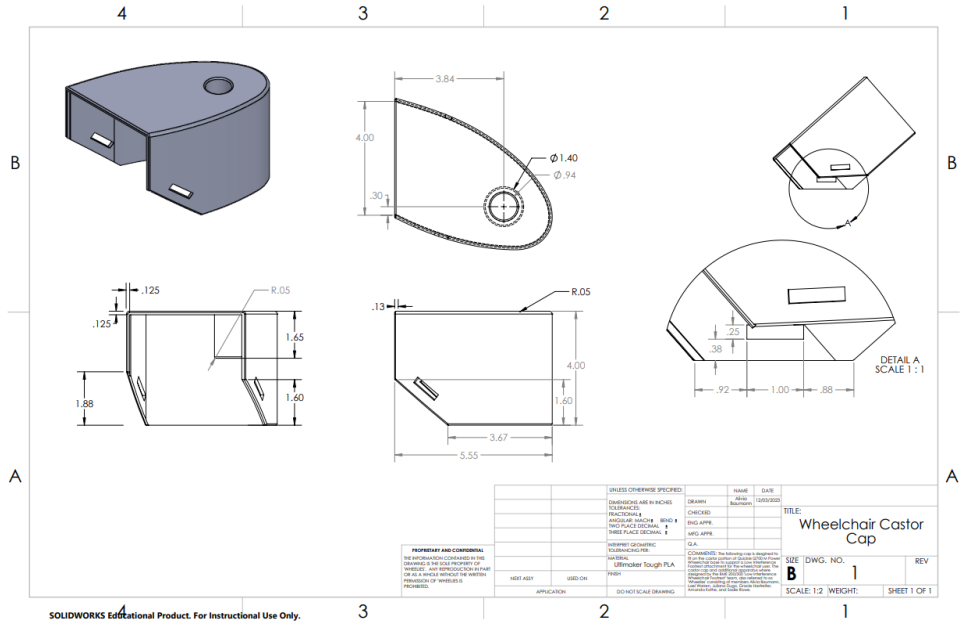
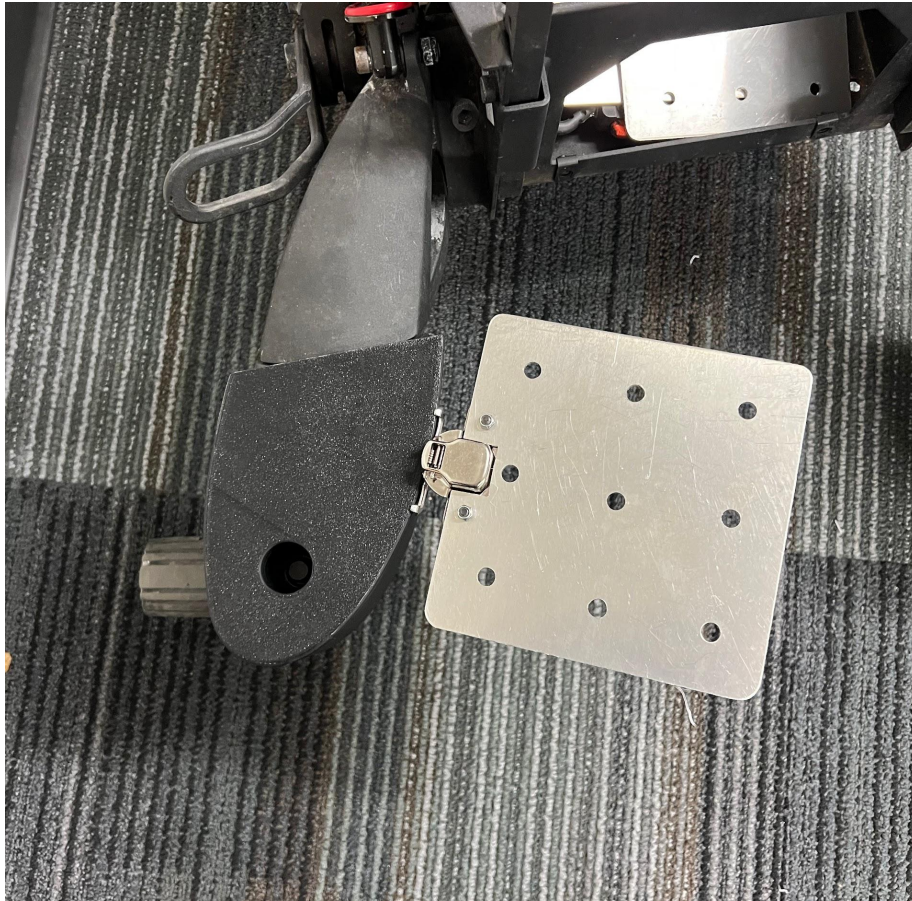

**Figure 6:** Final CAD Drawing of Castor Cap.



**Figure 7:** Castor cap inserted into the hole in the castors on the wheelchair





**Figure 8** : *Final Prototype of castor cap and footplate assembled with a 100-degree hinge from top view.*

The Fold-up Footrest final design was made by attaching the aluminum footplate to the castor cap with a 100-degree hinge, as seen in Figure 8. The design is similar to the proposed final design in that the footplate folds up 90 degrees in order to be out of the way when not in use, but remain on the wheelchair. Additionally, the final design has the ability to be removed and stored in two different ways; either by removing the footplate from the castor cap, or removing the entire device from the castor. Finally, the design was able to be confined to the castor region and therefore is not a large hindrance to other wheelchair functions, both when in use and not in use.

Unlike the proposed final design, there was no need to make a silicone mold of the castor, inserting a caliper into the hole and measuring was sufficient to get the dimensions needed to make the CAD drawing. Another difference from the initial design is the footplate does not span the entire length of the client's foot. In order to minimize weight and cost, the footplate was decreased in length; the intention is to have the footplate sit under the client's heel and arch in order to maintain stability.



## Testing

Various tests were conducted to test the functionality, stability, and ease of use of the prototype. As stated in the design specifications, the footrest must have a ground clearance of at least 3 inches. The ground clearance test was designed to test the device on various terrain conditions to ensure that the footplate does not interfere with the ground or obstruct any movement of the wheelchair base and wheels. Measurements for this test were largely qualitative. A team member pushed the wheelchair base with the device on the various terrains for 1 minute intervals. The terrains tested included tile floor, carpeted floor, concrete, and grass. Afterward, the device was rated on a scale of 1-10, with 1 meaning the device had significant clearance issues and 10 meaning the device had no clearance issues with the ground or other parts of the wheelchair base.

A force test was also performed to determine if the device is capable of supporting the force of the client's legs. The force of the client's leg is approximately 75 N or 16 lbs of force. The team decided to use a safety factor of 2, meaning the footrest should support double the force, a minimum of 149.60 N or 32 lbs. The footrest must be able to support this force while also maintaining structural integrity, specifically without deflecting more than 4 cm. If the device deflects more than 4 cm, the footplate will no longer be level with the ground, and the client's feet would be able to slip off the footplate. To test these requirements, weights are placed on the footplate in increments of 6 lbs. After each plate was added to the footplate, the deflection was measured and observations were recorded.

As stated in the design specifications, the device must be easily removed and attached to the device and the footplate must easily move between the folded up and folded down positions. Two tests were performed to determine ease of use of the device. The first was designed to test ease of use when maneuvering the footplate from its upright position to its usable position. In order to do so, 20 participants were asked to move the footplate from its upright position to its usable position and back again. Each participant was asked to rank the ease of their task on a scale from 1 to 10. A second similar test was conducted to measure the ease of use of attaching and removing the entire footrest device from the wheelchair castors. 20 participants were asked to take the prototype off of the castor by undoing the velcro strap and removing the cap. They were then asked to reattach the prototype and rank the ease of their task on a scale from 1 to 10.

## VI. Results

Each team member tested the wheelchair on all 3 terrains, meaning each terrain was tested 5 times. All scores of the terrain testing results were 10s, meaning that the prototype was able to clear all types of terrain and obstacles with at least a 3 inch clearance.

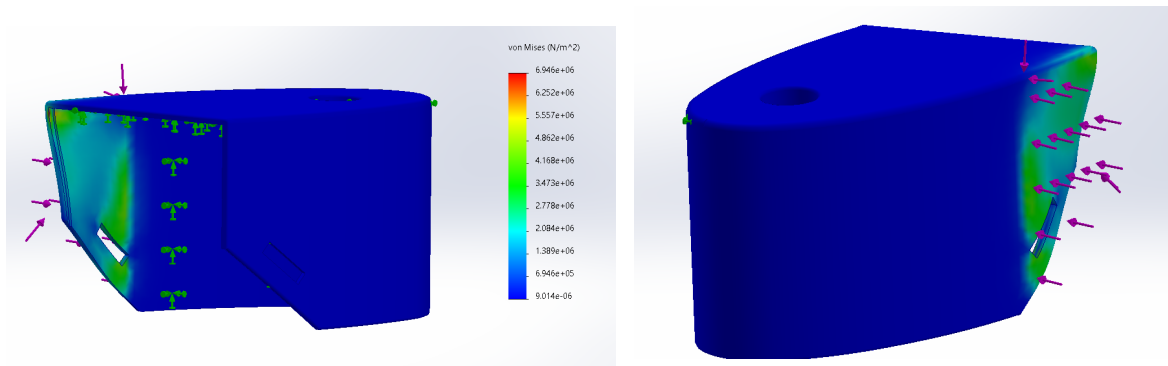

**Figure 9 & 10** : Results from Solidworks Force Testing

**Deflection (cm) of Footplate at Different Weights (lbs)**

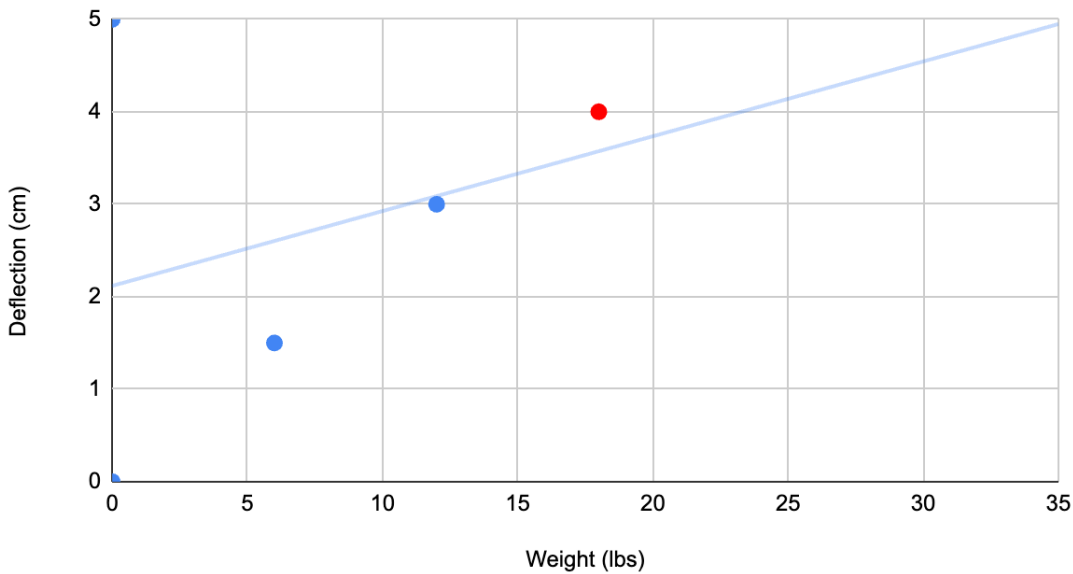

**Figure 11** : Graph of the Deflection (cm) of the footplate caused by different weights (lbs) being applied to it. Weights were applied in 6 lbs increments until the castor broke or the footplate deflected 4 cm. The red dot on the graph shows where the test failed, at 18 lbs. Not only did the footplate deflect 4 cm, the castor cap also broke.

In order to determine if the prototype was able to hold the necessary weight in order to support the clients foot and leg, two different force tests were performed. The first test was on Solidworks and from where the force is applied, Figures 9 and 10 detail where the resulting force was on the castor. This test shows where on the castor it is most likely to break due to the force applied. The results of this test show that near the back end of the castor, towards the wheelchair, where there is a straightedge and a slit is the most likely place for resulting forces to show and for the castor to break. The Deflection vs weight test shows was conducted until the prototype failed, which was either when the footplate deflected 4 cm or the castor cap broke. In order for the test to be successful, the prototype needed to support at least 30.5 pounds, deflect less than 4 cm, and not break. When there was no weight applied, the footplate had no deflection and sat at 0-degrees. At 6 pounds and 12 pounds the footplate deflected 1.5 and 3 inches, respectively. Showing a linear trend of deflection. However once 18 pounds was applied to the footplate, the castor deflected 4 cm and broke, resulting in a failed test. The red dot in the graph marks at which point the test failed. Because the prototype failed on the first test, more tests could not be conducted on the prototype.

### Ease of Use Maneuvering Footplate

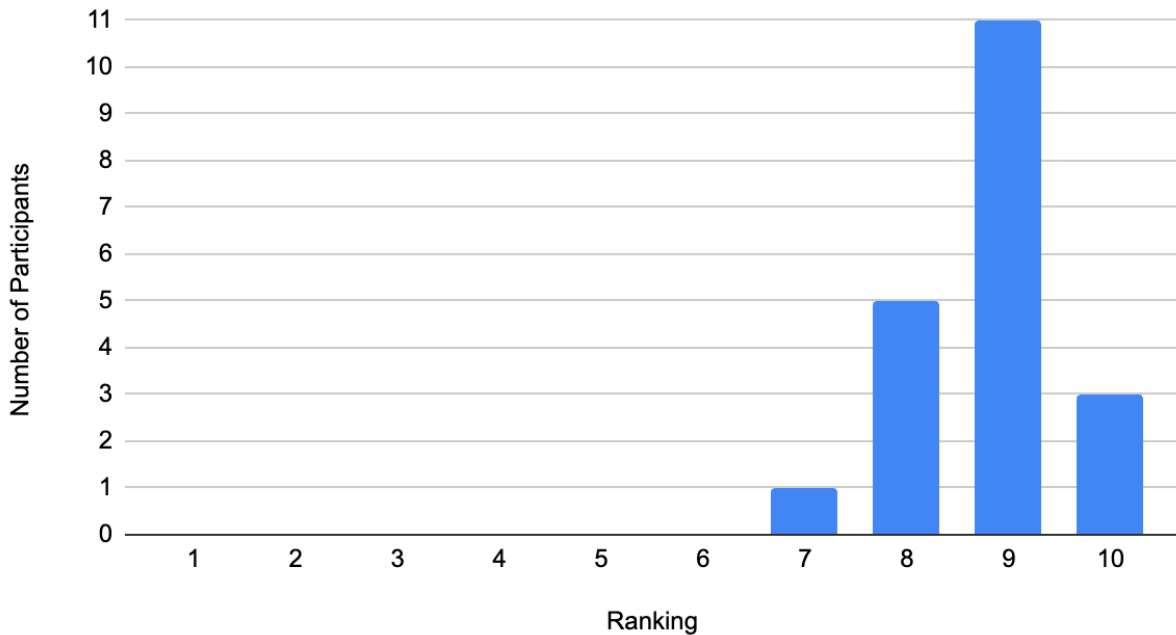

**Figure 12** : Histogram detailing the rankings that 20 participants gave for ease of use of maneuvering the footplate from the stored position to the usable position, and from the usable position back to the stored position.

### Ease of Use Taking Prototype On and Off

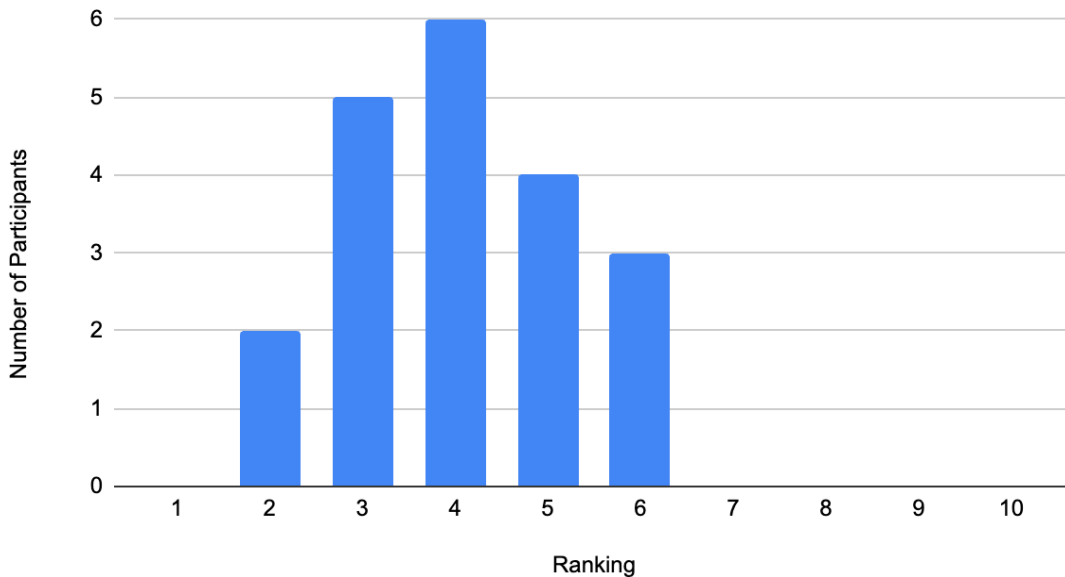

**Figure 13** : *Histogram detailing the rankings that 20 participants gave for ease of use of taking the prototype off the castor and then putting the prototype back on.*

A second set of tests were conducted in order to determine the ease of use of the prototype. The first one conducted was the ease of use maneuvering the footplate. The results of the 20 UW-Madison students who attempted to put the footplate in the usable and storage position shows a graph with a concentration on the upper values of the chart. The mode of the results was 9, with 11 participants giving that score. Qualitative feedback on this test included that it is easier to move the footplate into the stored position rather than the usable position; and that the soft close is nice for when you are putting it down into the usable position. The second ease of use test conducted was taking the castor cap on and off the castors. The results of this graph show the response concentration towards the lower ranking values, with the mode being a 4. The rankings for this ease of use test were more evenly distributed between the values given (2-6). Qualitative feedback for this test included that it was not hard to remove the cap from the castor but it was hard to put it back on, specifically the velcro. Other comments included that it is hard to bed down in the chair to take the cap on and off, and the question of where you would store the caps and footplates on the wheelchair if they were not in use.

## VII. Discussion

This product was designed around a specific model of a wheelchair, so it would only be useful for clients with a Quickie Power wheelchair. However, competing footrests often restrict leg movement and are not able to be removed while the wheelchair is in use. Therefore, it is possible that different clientele would benefit from a wheelchair footrest that can be stored on the wheelchair, allows for leg movement, and allows feet to reach the ground. In order to make the device more widely usable, different castor caps would have to be printed to fit the desired chair. The final design of the footrest consists of an aluminum footplate attached to a 3D printed castor cap with a 100 degree hinge.

Throughout the group's testing and research, main ethical considerations consisted of ensuring that the final product is safe to use and does not inhibit any functions of the wheelchair. The product should not affect the movement of the wheelchair by restricting the movement of the front wheels. Through testing, we were able to determine that the footrest does not inhibit the main functions of the wheelchair in any way, as it does not get in the way of the wheels, even considering deflection of the footplates when force is applied. Additionally, the product should not permanently alter or damage the wheelchair by putting more force on the castors than they are able to support. Throughout the testing process, the group attempted to ensure the product is able to support the force of the client's feet. However, when applying force during testing, the cap cracked and hindered the ability and safety of the footrest. Changes need to be made to the cap on top of the castor to ensure that it is able to support the weight of the client's feet without breaking. This could include support bars underneath the foot plate to help distribute the force, making the cap thicker, or adding extra support into the design so the cap fits the castor wheel better. The final ethical concern was that the product should not affect the client's transfer on and off of the wheelchair. Due to the position of the footplate, the footrest should not have any effect on the client's transfer into the wheelchair.

Throughout various stress tests and calculations, we diligently replicated the client's weight and abilities. For instance, to assess ease of use, a team member tested flipping the plate up and down while simulating the client's motion, focusing on vertical foot movement. Leveraging the soft close feature of the hinge made the rotation effortless, requiring just a slight push. However, the accuracy of our simulation is subjective without testing with the actual client. For stress tests, we calculated the weight of the client's legs. We acknowledge the potential variations as the client might shift sides adding additional pressures, so our findings are merely an estimation. Our calculations indicated that the aluminum's yield stress far exceeded the applied stress, ensuring a significant factor of safety. The footplate's deflection was negligible, and with testing, it was confirmed that all deflection originates from the hinge. Our current hinge raised concerns due to potential material weakness and the not-ideal 100-degree angle led us to

insert a metal piece limiting the angle to 80 degrees during unfolding, enhancing stability and preventing weight slippage. Another critical issue was the cap not being snug enough. This led to instability under eccentric loads, leading to torsion that twisted the cap out of its resting place, which added to the deflections observed.

Many different tests were completed to determine if the prototype meets the design specifications. Many of the design specifications were met for this prototype, however some were not. The prototype did have a combined weight below 3-4 pounds, and will have a lifespan of 4-5 years based on the material. Based on the properties of materials used, the device is also expected to be able to withstand 14-80 °F and be waterproof. The device has a ground clearance of 3 inches, and footplates are constructed of aluminum which can withstand a stress of 0.423 lb/in<sup>2</sup>. The production of the prototype did not exceed \$100, and the footrests do have the ability to fold out of the way. However, the prototype was not able to support a weight of 30.5 lbs, and test subjects were not able to easily remove and reattach the footrests.

Possible sources of error could arise from inaccurate measurements of the force of the client's feet that will be applied to the footrest. The force of the client's feet onto the footrest changes depending on the angle of the client's legs or if they are leaning forward or backward. Additionally, the client could lean to one side or the other, which would put additional pressure on one of the footrests. This could make it difficult to find an exact number for the weight the footrest must support. Additional sources of error arose in the testing of the prototype. While undergoing the force test, the castor cap portion of the design cracked. The structural integrity of the footrest failed, meaning the team was unable to test the full capabilities of the footplate and hinge components of the footrest. Another source of error in the testing was in the ease of use test maneuvering the footplate test. The client was unable to test the device, so the team moved forward with testing with fellow students. In the ease of use test maneuvering the footplate test, students rated the ease of moving the footplate between the folded up and folded down positions with their feet. This data creates a source of error because the team tested with able bodied individuals whose ease of motion could be different than individuals with a disability.

## **VIII. Conclusions**

Wheelchair users with limited movement capability are restricted by existing wheelchair footrest models. Current footrest models are heavy, bulky, and difficult to store. Because footrests are crucial for lower-body support, it is imperative to design a wheelchair footrest that allows for increased lower-body mobility—should the user require it. The goal of this project was to create a low-interference wheelchair

footrest that provides increased adaptability, functionality, and simplicity compared to existing models. To improve user experience, the team has developed design ideas and a detachable footrest prototype that is able to be moved from a usable position to a stored position on the wheelchair. Additionally, the group has conceptualized potential changes in the original design which may improve functionality and facilitate future work.

To begin the project, market research was conducted and the proposed final design was chosen after careful comparison to competing market designs. The team produced three design sketches and decided upon a final design based on comparison of weighted scores in various design criteria categories. The team's final proposed design was a variation of Design 1: The 'Fold up Footrest'. This prototype was created with attachment of a 3D-printed castor cap to a 6 by 6 in aluminum footplate via a 100 degree soft-close hinge. The castor cap was fit to insert into an existing hole on the castors and attached from the bottom with velcro straps for increased stability.

Several tests were conducted to evaluate the design specifications. The design successfully passed the ground clearance and ease of use maneuvering footplate tests. During testing, however, it was revealed that the selected design was not fit to accommodate adequate force and failed to support upwards of 18 lbs without significant deflection of the footplate. Additionally, the device does not meet design criteria pertaining to ease of use when attaching and removing the footrests as testing revealed that participants had a difficult time performing these tasks. Some aspects of the design worked well and should be incorporated into a revised prototype, such as the aluminum footplate, height of the footrests, and the general design concept. Although the selected hinge was unable to properly support necessary force, the aluminum footplate proved to be made of a sufficiently strong material and cut to a proportional size according to the client's feet. Additionally, the height of footrests allows adequate space for clearing any objects on the ground which might obstruct wheelchair movement and will likely be maintained in future revisions. The concept of the design proved to be an effective and lightweight alternative to current market options, but changes are required to improve the longevity and usability of the footrest design.

In future semesters, we plan to enhance our design's strength and functionality. A crucial adjustment involves upgrading the hinge to handle significant loads and distribute stress more evenly. Currently, stress concentrations and deflection stem from the hinge's axle, prompting consideration for a stronger hinge or a permanent modification, akin to the metal piece insertion we previously implemented. To counteract deflection, we're exploring a folded angle adjustment from 100 to 90 degrees or smaller, providing better support for clients' feet. Adding support under the footplate is also under consideration. Redesigning the cap to address fit issues and adjusting wall thickness for durability is another focus. Improvements to support mechanisms for the castor cap and exploring alternatives to velcro straps, such as a more efficient mechanism tailored to the client's mobility, are essential. Testing the product on the

client's current wheelchair is imperative for gathering data on long-term usage, stress distribution, and wear and tear.



## IX. References

- [1] “Worldwide Need,” Wheelchair Foundation,  
<https://www.wheelchairfoundation.org/fth/analysis-of-wheelchair-need/> (accessed Oct. 5, 2023).
- [2] “The benefits of a custom wheelchair: Ohio,” NPL Home Medical,  
<https://www.nplhomemedical.com/post/the-benefits-of-a-custom-wheelchair-ohio#:~:text=With%20a%20seemingly%2Dendless%20number,%2C%20cushions%20and%20head%2Darrays.> (accessed Sept. 15, 2023).
- [3] “Wheelchair rider injuries: Causes and consequences for wheelchair design and selection ,” Google Books,  
[https://books.google.com/books?hl=en&id=878PkR7AEHkC&oi=fnd&pg=PA58&dq=wheelchair&ots=yjd7q5rYzh&sig=IXkqTCztI1CAZGZTUIUWuP2QD7U#v=onepage&q=wheelchair&f=false](https://books.google.com/books?hl=en&amp;id=878PkR7AEHkC&oi=fnd&pg=PA58&dq=wheelchair&ots=yjd7q5rYzh&sig=IXkqTCztI1CAZGZTUIUWuP2QD7U#v=onepage&q=wheelchair&f=false) (accessed Sept. 8, 2023).
- [4] “Wheelchair management,” Occupational Therapy Assessment Guide,  
<https://otassessments.wordpress.com/wheelchair-management/> (accessed Oct. 10, 2023).
- [5] “Footrest options to support function and mobility,” Tips and advice, Motion Composites,  
[https://www.motioncomposites.com/en\\_us/community/blog/tips-and-tricks/footrest-options-to-support-function-and-mobility](https://www.motioncomposites.com/en_us/community/blog/tips-and-tricks/footrest-options-to-support-function-and-mobility) (accessed Sept. 20, 2023).
- [6] D. Stewart, “Wheelchair footrests,” Wheelchair Footrest Information,  
<https://mobilitybasics.ca/wheelchairs/footrests> (accessed Sept. 20, 2023).
- [7] A. for C. Innovation, “Spinal Seating Modules,” Keep the big picture in mind | Agency for Clinical Innovation,  
<https://aci.health.nsw.gov.au/networks/spinal-cord-injury/spinal-seating/module-10/keep-the-big-picture-in-mind> (accessed Sept. 30, 2023).
- [8] “Swing-away footrests,” Swing-Away Footrests | Accessories | Wheelchairs | Mobility | Products | Drive Medical US Site, <https://www.drivemedical.com/us/en/for-use-with/swing-away-footrests/p/1215-1> (accessed Sept. 20, 2023).
- [9] “Invacare Corporation - Product Catalog,” Invacare Homecare,  
[http://www.invacare.com/cgi-bin/imhqprd/inv\\_catalog/prod\\_cat.jsp](http://www.invacare.com/cgi-bin/imhqprd/inv_catalog/prod_cat.jsp) (accessed Sep. 20, 2023).

- [10] “Drive Medical Swing Away Footrests,” Vitality Medical.  
<https://www.vitalitymedical.com/wheelchair-swing-away-footrests-stds3j24sf.html> (accessed Sept. 20, 2023).
- [11] “Why are wheelchair footrests essential for posture?,” Passionate People by Invacare,  
<https://www.passionatepeople.invacare.eu.com/wheelchair-footrests-essential-posture/> (accessed Sept. 30, 2023).
- [12] “Guide to good posture,” MedlinePlus, <https://medlineplus.gov/guidetogoodposture.html> (accessed Sept. 20, 2023).
- [13] Quickie Q700 M / Q700 M HD - Sunrise Medical,  
[www.sunrisemedical.com/getattachment/f2db9ac9-1c2b-4dcc-903e-cafdbacb5111/Quickie-Q700-M-Owner-s-Manual.aspx](http://www.sunrisemedical.com/getattachment/f2db9ac9-1c2b-4dcc-903e-cafdbacb5111/Quickie-Q700-M-Owner-s-Manual.aspx). (Accessed 22 Sept. 2023).
- [14] D. A. Winter, “Anthropometry Tables,” in *Biomechanics and motor control of human movement*, 4th ed, Hoboken, NJ: John Wiley, 2009
- [15] “The Online Materials Information Resource,” MatWeb,  
<https://www.matweb.com/search/datasheet.aspx?matguid=b8d536e0b9b54bd7b69e4124d8f1d20a&ckck=1> (accessed Sept. 20, 2023).
- [16] J. R. Davis, Corrosion of Aluminum and Aluminum Alloys. Materials Park: ASM International, 1999 (accessed Sept. 20, 2023).
- [17] University of Wisconsin-Madison. (n.d.). *3D Print Guide on Ultimaker Tough PLA*. UW Makerspace. <https://making.engr.wisc.edu/3d-printing-the-makerspace/> (accessed Dec. 1, 2023).
- [18] “Climate and Average Weather Year Round in Wisconsin,” Wisconsin Climate, Weather By Month, Average Temperature (United States) - Weather Spark, <https://weatherspark.com/countries/US/WI> (accessed Nov. 29, 2023).

# X. Appendix

## A. Product Design Specification (PDS)

### **Function:**

There are currently no wheelchairs on the market which allows those who are not paralyzed to perform helpful movements, such as opening doors with their feet or being able to pick up objects from the floor. In addition, current footrest models are heavy, bulky, and not easily able to be removed and stored when not in use. While footrests are crucial for support if the wheelchair tilts or reclines, it is imperative to design a wheelchair footrest that allows for more foot mobility- should the user require it- and for easier storage of said footrests. The updated footrests should be able to adapt to a person's abilities, should be easily able to remove and store them when not in use, and be lighter and less bulky, while still providing the benefits of a footrest when necessary.

### **Client requirements:**

- I. Combined weight between 3-4 lbs
- II. Ability to fold footrest up or be able to easily remove and store them
- III. If removable, a place to store them so they are accessible but not a hindrance
- IV. Ability to move with wheelchair (i.e. move with the rest of the chair when chair tilts backwards)
- V. Have calf support

### **Design requirements:**

#### **1. Physical and Operational Characteristics**

##### *a. Performance requirements:*

- I. The wheelchair footrests must have an equivalent lifespan of wheelchair base (between 4-5 years [1]). Production cost should not exceed \$100 to maintain reproducibility and combined weight may not exceed 4 lbs. The footrests must be able to be stored on the wheelchair.

##### *b. Safety:*

- I. Any materials used to construct wheelchair footrests must not include sharp edges.
- II. Footrests should hinder the user's foot and leg from sliding backwards into the base of the wheelchair as to ensure comfort and safety.
- III. Footrest accessories must be removable or at swing at least 90 degrees out foot space in order to avoid accidents when the user transfers into/out of the wheelchair seat.

##### *c. Accuracy and Reliability:*

- I. The footrest must be able to connect to the base of the wheelchair and support the weight of the client's feet, or 15.25 lbs [12], with a factor of safety of 2 [13], every time it is attached.

d. *Life in Service:*

- I. Footrest should have the same lifespan as a typical wheelchair base, which is an average of 4-5 years [1].

e. *Shelf Life:*

- I. The footrest must be able to last as long as the client will be using the specific wheelchair that the footrest will attach to, 5 years. [2]

f. *Operating Environment:*

- I. The footrest must be able to operate both indoor and outdoors. The footrests should be able to withstand a temperature range of 14-80 °F [10] and be waterproof. In addition, the footrests should be able to clear multiple types of terrain and flooring. To ensure good clearance with room to spare, the footrests must sit at least 3 inches above the ground.
- II. The footrest must be able to support the force of the client's feet, or 149.60 N, with a factor of safety 2, therefore 299.21 N [12].

g. *Ergonomics:*

- I. The footrest must be able to support the client's feet while also not restricting leg movement or the client's ability to put their feet on the ground.

h. *Size:*

- I. The footrest, if two separate pieces, should accommodate wider than the shoe's width, but can be shorter while supporting the majority of the foot's length. The size of our footrest should accommodate a variety of sizes and can be based on average shoe sizes. Based on the average men's shoe being a 10.5 with measurements of 11.645 by 4.25 inches [3], the footrest's dimensions can be around 7 by 5 inches.
- II. The footrest, if one piece, should accommodate for a shoulder width apart orientation of feet, or 41 cm based on the average distance between shoulders in men in the United States [11].

i. *Weight:*

- I. The weight of our entire design should be a maximum of 3-4 lbs, per client's request.

j. *Materials:*

- I. The foot plate should be constructed of a durable material that is able to withstand a stress up to 0.4236 lbs/in<sup>2</sup> [12], and a temperature range of 14-80 °F [10], and last the equivalent lifespan of the wheelchair base, around 5 year [1]. Potential materials include Aluminum Alloy (7075-T6 or 6061-T6), stainless steel, plastic, or polyvinyl chloride (PVC), which can withstand a yield strength up to 10,000 psi, 1910 psi, and 25,000 psi, respectively [14].

k. *Aesthetics, Appearance, and Finish:*

- I. The final configuration of the footrest can not impede any other relevant functions of the wheelchair or user safety. Other relevant functions include raising and lowering the wheelchair, transferring to and from the wheelchair, going over uneven terrain, fitting through doorways, and driving a car.
- II. The aesthetics and appearance aspects of the product are not relevant to the final design so long

as they meet the other requirements detailed in this document.

## **2. Production Characteristics**

### *a. Quantity:*

- I. The client requires a single prototype to be used as an attachment to his current wheelchair. With successful creation of one prototype, more could be created for a larger population.

### *b. Target Product Cost:*

- I. The target cost of the product provided by the client is within \$100.

## **3. Miscellaneous**

### *a. Standards and Specifications*

- I. ISO 7176: This standard states testing guidelines for various mechanical components off the wheelchair. Parts 1 and 2 [4][5] refer to static and dynamic stability of the wheelchair movement. Other parts refer to wheelchair dimensions, maneuvering space, durability, etc. Since the apparatus would affect the physical properties of the wheelchair itself, these are important to note.

### *b. Customer:*

- I. The customer for this product is our client Mr. Dan Dorszynski. He dislikes the current footrest options that restrict his ability to use his feet for small everyday actions, such as opening a door. The customer would like the rest of the wheelchair to stay the same, with modifications only being made to the castor attachments.
- II. While this product is being designed with a specific customer in mind, if similar frustrations are faced by other wheelchair users with degrees of mobility, the final product could potentially be utilized in other similar situations.

### *c. Patient-related concerns:*

- I. The final product is one such that it may require some modification or attachment to the clients wheelchair. As the wheelchair is a necessary component of our clients everyday life, it is essential that any building, testing, and final product allow all other functions of the wheelchair to remain intact.

### *d. Competition:*

- I. There are many other wheelchair footrests on the market today with varying design elements. These include, but are not limited to, models from Drive Medical [9], Invacare Corporation [6], Comfort Company [7], and Therafin Corporation [8].
- II. Prices generally start at \$40 and range upwards of \$300 [9].

## References

\*any quantitative information without references came directly from the client, Mr. Dan Dorszynski\*

[1] Ngamwongsa-Nguan, Panya & Arayawichanon, Preeda & Manimmanakorn, Nuttaset. (2017). Manual Wheelchair Longevity and Related Factors among Spinal Cord Lesion Patients. *Asia-Pacific Journal of Science and Technology*. 22. 1-6.

[2] Quickie Q700 M / Q700 M HD - Sunrise Medical, [www.sunrisemedical.com/getattachment/f2db9ac9-1c2b-4dcc-903e-cafdbacb5111/Quickie-Q700-M-Owner-s-Manual.aspx](http://www.sunrisemedical.com/getattachment/f2db9ac9-1c2b-4dcc-903e-cafdbacb5111/Quickie-Q700-M-Owner-s-Manual.aspx). (Accessed 22 Sept. 2023).

[3] "Brannock Device® Foot-Measuring Device User Guide" by The Brannock Device Co., Inc.

[4] ISO. (2014). Wheelchairs — Part 1: Determination of static stability. <https://cdn.standards.iteh.ai/samples/56817/abc81b2284d1465f91679e4588c269be/ISO-7176-1-2014.pdf>

[5] ISO (2014). Wheelchairs — Part 2: Determination of dynamic stability of electrically powered wheelchairs. <https://cdn.standards.iteh.ai/samples/57753/61ac15402fd74aee98b3aa1803400f2b/ISO-7176-2-2017.pdf>

[6] "Invacare Footrest Assembly," Quickie Wheelchairs. <https://www.quickie-wheelchairs.com/Wheelchair-Parts-Accessories/Assorted-Wheelchair-Parts/Footrests-Legrests/Invacare-Footrest-Assembly-3-1-8-Pin-Spacing-Pair/24518p> (accessed Sep. 20, 2023).

[7] "Comfort Calf Protector," Quickie Wheelchairs. <https://www.quickie-wheelchairs.com/Wheelchair-Positioning/Lower-Extremity/Comfort-Calf-Protector/27557p> (accessed Sep. 20, 2023).

[8] "Ankle Supports - Velcro Closures" Quickie Wheelchairs. Ankle Supports - Velcro Closures | Lower Extremity ([quickie-wheelchairs.com](http://www.quickie-wheelchairs.com)) (accessed Sep. 20, 2023).

[9] "Drive Medical Swing Away Footrests," Vitality Medical. <https://www.vitalitymedical.com/wheelchair-swing-away-footrests-stds3j24sf.html> (accessed Sep. 20, 2023).

[10] "Climate and Average Weather Year Round in Wisconsin," Wisconsin Climate, Weather By Month, Average Temperature (United States) - Weather Spark, <https://weatherspark.com/countries/US/WI> (accessed Nov. 29, 2023).

[11] K. Watson, "Average shoulder width and how to measure yours," Healthline, <https://www.healthline.com/health/average-shoulder-width#the-takeaway> (accessed Nov. 29, 2023).

[12] D. A. Winter, "Anthropometry Tables," in *Biomechanics and motor control of human movement*, 4th ed, Hoboken, NJ: John Wiley, 2009

[13] A. Winter and R. Hotchkiss, "Mechanical Principles of Wheelchair Design ," PDF.live, [https://pdf.live/edit?url=https%3A%2F%2Fweb.mit.edu%2Fawinter%2FPublic%2FWheelchair%2FWheelchair+Manual-Final.pdf&guid=a122f460-b73d-6198-17e9-ed1b87378a5d&installDate=092523&source=google-d\\_pdftab\\_crx](https://pdf.live/edit?url=https%3A%2F%2Fweb.mit.edu%2Fawinter%2FPublic%2FWheelchair%2FWheelchair+Manual-Final.pdf&guid=a122f460-b73d-6198-17e9-ed1b87378a5d&installDate=092523&source=google-d_pdftab_crx) (accessed Dec. 1, 2023).

[14] J. Lie, "Metal Strength Chart," Ransom Precision, <https://www.ransom.com/design-tips/metal-strength-chart/> (accessed Dec. 1, 2023).

## B. Expenses and Purchases

Part Type/Name	Unit Price (\$)	Quantity	Total Price (\$)	Source	Dimensions	Link
Aluminum Sheet	\$19.25	1	\$19.25	Makerspace	6 in x 6 in x 1/8 in	N/A
90 Degree Hinge	\$3.75	4	\$14.99	Amazon	2.4" L x 1.8" W	<a href="#">link</a>
100 Degree Hinge	\$5.00	2	\$9.99	Amazon	3.34" L x 2.44" W	<a href="#">link</a>
Demo Cap	\$12.88	1	\$12.88	Makerspace	161 g (.08 cents/gram) Tough PLA	N/A
Velcro Strap	\$0.75	4	\$3.00	Makerspace	12 in x 1 in	N/A
3D Printed Cap	\$10.89	1	\$10.89	Makerspace	132 g (.08 cents/gram) Tough PLA	N/A
		<b>Total Items:</b>	<b>Total Price:</b>			
		13	\$71.00			

## C. Testing Protocols

### 1. Name of testing protocol/portion of prototype: Ground Clearance

**Date to be completed:** 12/5/23

#### Detailed Steps of testing:

The device will be tested on different terrain conditions to ensure ground clearance of each individual footrest. Terrain conditions will include tile flooring, carpeting flooring, concrete, and grass/dirt. Measurements will be largely qualitative, taking note of the interaction between the footplates and both the castors, wheels, and the ground. A scale from 1-10 will be used to quantify how well footplates are able to avoid interaction with the ground, with 10 meaning there are no clearance issues.

1. Terrain testing
  - a. Manually propelling devices for 1 min intervals at each terrain (tile flooring, carpeted flooring, concrete, and grass/dirt)
  - b. At the end of each interval, record observations and notes on ease of use and surface interaction
  - c. Repeat (a), (b) and (c) for a second trial.
  - d. After all trials, quantify observations into 1-10 scale.

Data from this test will be analyzed using a median to find the average. If the average is under 80% of full possible functionality, then further revision of the design is required and the tests will be rerun.

#### Data Collection:

Terrain	Clearance Rating (1-10)		
	Trial 1	Trial 2	Trial 3
Tile Flooring	10	10	10
Carpeted Flooring	10	10	10



Concrete	10	10	10
Grass/Dirt	10	10	10

Observations: The footplates have a clearance of 28 cm from the ground and do not impede motion or interfere with castors and wheels.

**2. Name of testing protocol/portion of prototype:** Force Testing

**Date to be completed:** 12/5/23

**Detailed Steps of testing:**

Footrests will be tested with various weights to test stability and structural integrity. The footrests must be able to withstand the weight of the clients legs while resting in addition to any applied force if the footrests are used as leverage when moving around. This will consist of a load to failure test.

1. Weight will be tested at 6 pound increments for visible changes and failures in structural integrity
  - a. Photos of the footrests will be taken at each weight increment
  - b. Measurement of footplate deflection will be tested after each new addition of weight
  - c. 4 cm deflection is acceptable
  - d. Footrests should support a minimum weight of 15.25lbs
  - e. Weight of failure will be recorded unless the device can withstand over 30.5 lbs

**Data Collection:**

Weight (lbs)	Deflection (cm)	Observations
0	0 cm	Footplate rests slightly above 90°
6	1.5 cm	
12	3 cm	
18	4 cm	Opposite side cracked FAIL
24		
30		
36		
42		

### 3. Name of testing protocol/portion of prototype: Ease of Use Maneuvering Footplate

**Date to be completed:** 12/5/2023

#### **Detailed Steps of testing:**

The testing will be completed using a survey in which a minimum of 5 participants will rank the ease of use of footrests on a scale of 1-10.

**Setup:** Set a chair over the wheelchair base to simulate the chair on the wheelchair. Ask participants to sit in the chair and then move the footrests from their stored position to their usable position. Then move the footplate from the usable position back to the stored position. Ask them to rank how easy it was to complete those tasks on a scale from 1 to 10.

#### **Data Collection:**

Participant	Ease of Use Score (1-10)
1	9
2	9
3	9
4	10
5	9
6	8
7	8
8	9
9	9
10	7
11	10
12	10
13	9
14	8
15	9
16	9
17	9

18	8
19	8
20	9

**Qualitative Feedback:**

- Easier to move them into the stored position then to move them down into the usable position
- Soft close is nice for when you are putting it down into the usable position

Ease of Use Maneuvering Footplate

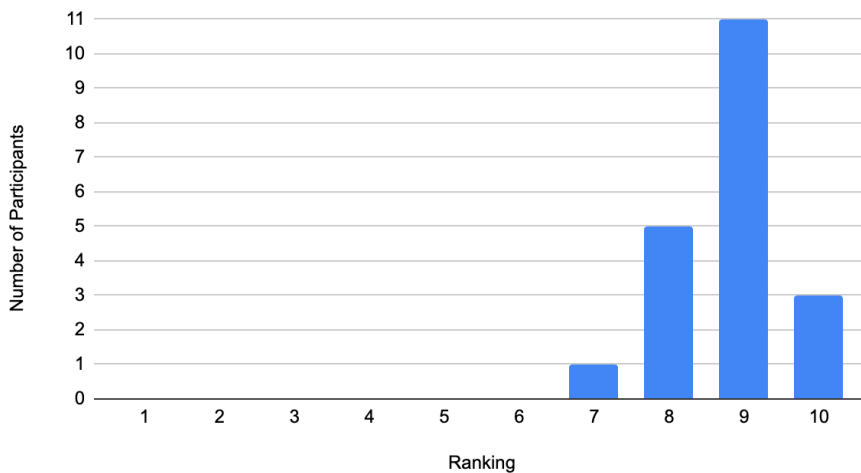

**4. Name of testing protocol/portion of prototype:** Ease of Use Taking Prototype on and off

**Date to be completed:** 12/5/2023

**Detailed Steps of testing:**

The testing will be completed using a survey in which a minimum of 5 participants will rank the ease of use of footrests taking the prototype on and off on a scale of 1-10.

**Setup:** Set a chair over the wheelchair base to simulate the chair on the wheelchair. Ask participants to sit in the chair and then have them take the prototype off the castor by undoing the velcro and removing the cap. Then ask them to put the prototype back on by inserting the cap into the hole and having them strap the velcro onto the bottom of the castor. Ask them to rank how easy it was to complete those tasks on a scale from 1 to 10.

**Data Collection:**

Participant	Ease of Use Score (1-10)
1	2
2	5
3	3
4	6
5	3
6	4
7	3
8	4
9	5
10	4
11	6
12	2
13	3
14	4
15	4
16	6
17	3
18	4
19	5
20	5

**Qualitative Feedback:**

- Not hard to remove the cap from the castor but hard to put it back on
  - Inserting the cap is easy but getting the velcro back on is hard
- Bending all the way over can be difficult, especially if the client has restricted movement, so that could pose an issue for getting the cap on and off
- Question: where would you store the caps and footplates on the wheelchair if they were not in use?

### Ease of Use Taking Prototype On and Off

