

Progress Report - Week 11

Title: Stabilizer Device for Intra-Cardiac Echocardiography (ICE) to Assist Structural Heart Interventional Procedures

Client: Dr. Amish Raval

Advisor: Dr. Darilis Suarez-Gonzalez

Team: Sara Morehouse (Leader)

Max Aziz (Communicator)

Noah Hamrin (BWIG & BPAG)

Kaden Kafar (BSAC)

Date: November 21, 2024

Problem Statement:

Intracardiac echocardiography (ICE) is a technique commonly used during catheter-based interventional procedures to treat congenital heart disease, valvular heart disease and myocardial disease. Typically, the ICE catheter is advanced into the right atrial from a femoral vein, where it is positioned for imaging purposes. A separate catheter to perform the interventional procedure such as a transeptal needle or Watchman left atrial appendage occluder delivery system is then introduced. Many times, the ICE catheter drifts out of place, the imaging perspective is lost and the ICE catheter needs to be readjusted. Therefore, there exists a need for a simple re-sterilizable device to stabilize a variety of commercially available ICE catheters during interventional procedures. The device must prevent movement of the ICE catheter so that it does not migrate out of place when in use.

Brief Status Update:

This week, the team focused on prototyping. We have ordered materials that we are currently waiting for, but while we are waiting we 3D-printed another functional prototype to begin initial testing of the device with. As soon as additional materials arrive, we will complete further testing in order to prepare for our Final Presentation for this semester.

Difficulties / Advice Requests:

N/A at this time.

Current Design:

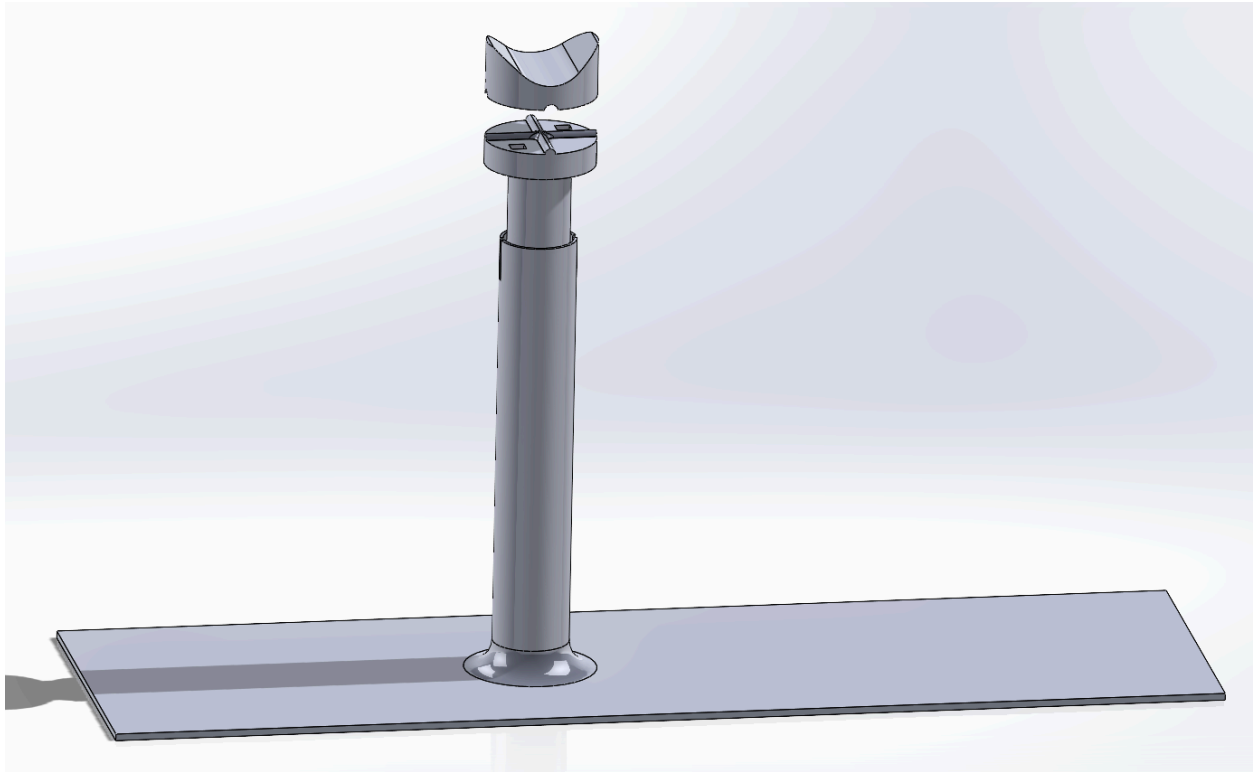

The Body Weight Holder design consists of 3 main components: the base plate, the shaft, and the top holder. The base plate will be welded to the bottom part of the shaft, and the top part of the shaft will be inserted into the bottom shaft and held in place with a quick release clamp. This clamp will allow for adjustable height. The top part of the shaft includes a circular base that will have magnets, which will attach to the top holder component. The magnets will allow the top holder to be secured to the shaft through a surgical sterile drape. Additionally, the top holder will be lined with rubber on the internal surface to provide a secure hold on the catheter handle. There will also be rubber straps that secure over the handle of the catheter.

Materials and Expenses:

Item	Description	Manufacturer	Mft Pt#	Vendor	Date	#	Cost Each	Total	Link
3D printed prototype	3D-printed model of our initial prototype concept	n/a	n/a	MakerSpace	10/31/24	1	\$6.97	\$6.97	n/a
PLATT Bike	Quick release	PLATT	n/a	Amazon	11/8/24	1	\$8.99	\$8.99	amazon.com

Seat Post Clamp Aluminium Alloy Bicycle Quick Release Seatpost Collar 34.9mm	clamp - 34.9 mm size								
McMaster 5848K11	1/4" x 1/4" x 1/8" magnet	McMaster	5848K11	McMaster	11/8/24	2	\$2.57	\$5.14	https://www.mcmaster.com/5848K11
McMaster 5848K15	3/8" x 3/8" x 1/8" magnet	McMaster	5848K15	McMaster	11/8/24	2	\$3.10	\$6.20	https://www.mcmaster.com/5848K15
McMaster 5848K83	1/4" x 3/4" x 1/4" magnet	McMaster	5848K83	McMaster	11/8/24	2	\$6.76	\$13.52	https://www.mcmaster.com/5848K83
DGSL Neoprene Rubber Sheet	1" Wide x 1/16" Thick x 10' Long Rubber sheet	DGSL	n/a	Amazon	11/8/24	1	\$9.99	\$9.99	amazon.com
Adhesive Rubber Strips Neoprene Rubber Sheets, Rolls & Strips with Adhesive Backing	2" Wide x 1/16" Thick x 10' Long Rubber sheet with adhesive backing	n/a	n/a	Amazon	11/8/24	1	\$12.98	\$12.98	amazon.com
McMaster 89955K169	1-3/8" OD shaft - 1ft long	McMaster	89955K169	McMaster	11/8/24	1	\$29.37	\$29.37	https://www.mcmaster.com/89955K169
McMaster 89955K959	1-1/8" OD - 1 ft long	McMaster	89955K959	McMaster	11/8/24	1	\$25.20	\$25.20	https://www.mcmaster.com/89955K959
McMaster 4459T188	Sheet metal 4130 easy-to-weld steel 6"x36"	McMaster	4459T188	McMaster	11/8/24	1	\$63.80	\$63.80	https://www.mcmaster.com/4459T188

Meetings														
Client	X					X		X						
Advisor	X		X	X		X			X		X			
Website														
Update	X	X	X	X	X	X	X	X	X	X	X			

Previous week’s goals and accomplishments:

- Fabricate prototype when materials arrive
 - We 3D-printed a functional prototype, however are still waiting for a few materials to arrive.
- Complete testing
 - This week, we are beginning to test tomorrow, and will finish up any additional tests early next week.

Activities:

Name	Date	Activity	Time (h)	Week Total (h)	Sem. Total (h)
Sara	11/19/24	3D printed prototype, worked on testing and fabrication protocols.	2	2	25
Max	11/19/202	3D printed prototype and worked on testing protocols	2	2	24
Noah	11/15/24	Refined solidworks model based on initial prototype	2	2	27
Kaden	11/15/24	3d Printed updated model, worked on testing protocol, and fabrication protocol	2	2	20