

# Preliminary Deliverables

October 9th, 2024

Section 302

Affordable Diagnostic EEG System for Viral-induced Epilepsy

Team Lead: Richard Yang  
Communicator: Ellie Dingel  
BSAC: Mark Rice  
BWIG & BPAG: Elliott Harris

Client: Dr. Brandon Coventry, Department of Neurosurgery  
Advisor: Prof. Amit Nimunkar, Department of Biomedical Engineering

## **Abstract**

Epilepsy is a common chronic neurological disease characterized by abiding recurrent seizures. Electroencephalogram (EEG) is the most widely used detection and analysis procedure for epilepsy, which records cortical electrical activity. However, 80% of epilepsy patients live in low- and middle-income countries, the majority of which do not have access to EEG systems or treatments. Therefore, affordable EEG systems that can be rapidly and broadly deployed are in critical need. In this work, we show the development of an affordable diagnostic EEG system replete with ten channels, high temporal resolution, and a flexible 3D-printed head cap.

## Table of Contents

<b>Abstract</b>	<b>2</b>
<b>Table of Contents</b>	<b>2</b>
<b>Introduction</b>	<b>4</b>
<b>Background</b>	<b>4</b>
<b>Preliminary Designs</b>	<b>5</b>
Headcap	5
Store-bought Head Cap	5
DIY Head Cap	5
Naked Electrode	6
3D-printed Head Cap	7
Circuits	7
Single-channel Analog-to Digital Converter + Multiplexer	7
Multi-Channel Analog-to-Digital Converter	8
<b>Preliminary Design Evaluation</b>	<b>9</b>
Proposed Final Headcap Design	9
Circuits	10
<b>Fabrication</b>	<b>11</b>
Headcap	11
Materials:	11
Methods	12
Circuits	12
Materials:	12
Methods	12
Final Prototype	12
<b>Testing and Results</b>	<b>13</b>
Head Cap Evaluation	13
Comfort Assessment	13
Spatial Accuracy Assessment	13
Analog Front End Printed Circuit Board Evaluation	13
Functionality Check	14
Signal Quality Quantification	14
Frequency Response	14
Signal-to-Noise Ratio (SNR)	14
Common Mode Rejection Ratio (CMRR)	14
<b>Conclusions</b>	<b>14</b>
<b>References</b>	<b>15</b>
<b>Appendix</b>	<b>16</b>
<b>A: Material Cost Summary</b>	<b>16</b>

<b>B: Product Design Specifications</b>	<b>17</b>
<b>Function</b>	<b>17</b>
<b>Client requirements</b>	<b>17</b>
<b>Design requirements</b>	<b>17</b>
Physical and Operational Characteristics	17
Performance requirements	17
Safety	17
Accuracy and Reliability	17
Life in Service	18
Shelf Life	18
Operating Environment	18
Ergonomics	18
Size	19
Weight	19
Materials	19
Aesthetics, Appearance, and Finish	19
Production Characteristics	19
Quantity	19
Target Product Cost	20
Miscellaneous	20
Standards and Specifications	20
Customer	21
Patient-related concerns	21
Competition	22
<b>Reference</b>	<b>22</b>
<b>C: Design Matrix</b>	<b>24</b>
<b>Electrode Cap</b>	<b>24</b>
<b>Electronics</b>	<b>26</b>

## Introduction

It is estimated that 1 in 26 Americans develops Epilepsy at some point in their lifetime. Epilepsy is a neurological disorder that causes sporadic seizures [1]. Various treatments exist for Epilepsy, such as anti-seizure medications (AEDs), ketogenic diets, seizure-preventing devices, and even surgery [2]. However, diagnosis of the sub-type of Epilepsy is required before a treatment plan can be devised. The primary way to detect Epilepsy without observing recurring seizures is through an electroencephalogram (EEG) [3]. The EEG system is placed on the patient's scalp and is used to detect the electrical impulses in the human brain. Currently, EEG devices are expensive and difficult to obtain. Medical-grade EEG systems cost tens of thousands of dollars, and open-source projects are still prohibitively expensive. OpenBCI, a partially open-source project known for its brain-computer interface devices, offers an eight-channel biosensing board, EEG cap, and electrodes for \$2,578 [4]. Although this device may be effective, areas without the necessary resources could not afford a stock of these devices to detect and diagnose epilepsy. 80% of epilepsy patients live in low- and middle-income countries, the majority of whom have access to treatment but not diagnostic equipment [5]. This project aims to create a reliable, accurate, and inexpensive EEG device. The product must receive, process, and display signals from ten channels in a format that a medical professional can easily interpret.

## Background

Epilepsy is a brain disorder characterized by abnormal neuron activity, leading to misfires in the brain and resulting in seizures. Two or more of these seizures, with an unknown cause, is what is called Epilepsy. Anyone at any age can develop Epilepsy. However, it is most common in early childhood or old age [1]. EEG can detect miscommunications between neurons. These channels that detect those miscommunications will tell the physician that the patient may have epilepsy. Using more channels across different brain regions can give a higher chance of detecting these disruptions in brain activity. One study found that Epilepsy affects the hippocampus, amygdala, frontal cortex, temporal cortex, and olfactory cortex most often. However, disruptive activity can be detected across many brain regions [6]. This justifies the constraint of 10 channels rather than eight or fewer channels, giving a higher chance of detection.

Neurodiagnostic tests like EEG are challenging to perform in less fortunate areas. A study completed by the American Academy of Neurology says that in most low-income countries surveyed during the study, only the top 10% or 20% of the population could afford tests below catastrophic levels. In surveyed lower-middle-income countries, >40% of the population, on average, could not afford neurodiagnostic tests [3]. Brandon Coventry, a post-doctoral fellow in the Department of Neurosurgery at the University of Wisconsin School of Medicine and Public Health, decided to create this project to find a way to solve this problem. For the device to be useful for less fortunate areas, Brandon aims to keep the production cost under 100 dollars. This device must also be compatible with various head shapes and sizes. The team found that the 50-64 cm circumference range would capture all regular occurring head sizes [7]. The device must remain in operation for 3-4 years without a dip in performance. The device must be able to be transported, stored, and implemented in a variety of temperatures depending on the environment. Please see Appendix B for the team's complete product design specifications for this product.

This project also includes the processing of weak signals from the brain. This consists of filtering and amplifying the signal. The team must also find a way to keep this design cheap and easy to fabricate. Filtering unwanted signals is vital in any environment where capacitive coupling from the powerline and other electrical interferences exist. One commonly used filtering technique is a bandpass filter, which uses a circuit of varying electrical components to achieve a calculated sampling frequency. Instrumentation amplifiers are critical elements extensively used for input buffering and high voltage gain [8].

## Preliminary Designs

### Head Cap

To acquire an accurate EEG signal, electrodes must be secured on the head in standardized placements, usually achieved through a head cap. The team explored four designs: store-bought head cap, DIY head cap, naked electrode, and 3D-printed head cap.

#### Store-bought Head Cap

Purchasing an already existing product gives the benefit of a tested market product that provides a reproducible reading each time. However, for an open-source project, a 3rd party head cap design is subject to potential hurdles such as price changes and supply chain availability in the given region.

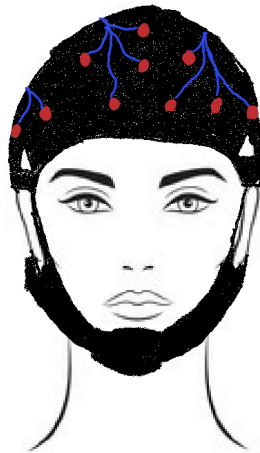

Figure 1: Store Bought Head Cap Concept Drawing

Figure 1 shows a representative concept drawing of many available EEG cap designs similar to the OpenBCI Head Cap [9]. Commercially available EEG head caps like this may be at various prices. On the higher end, the OpenBCI Head Cap [9] costs around \$500, while cheaper ones, like the Contec Head Cap [9], may cost only \$16.

#### DIY Head Cap

To keep costs as low as possible, a “do it yourself” or DIY design was considered where a set of measurements would be provided to modify common existing objects such as winter hats or baseball caps.

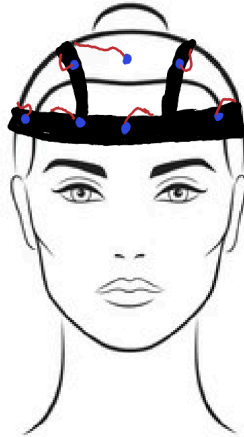

Figure 2: DIY Head Cap Concept Drawing

This design, represented by Figure 2, has limitations of repeatability. Misunderstanding of instructions could lead to incorrect measurements and potentially incorrect diagnosis. Additionally, each head cap would be different, providing varying readings, making design verification difficult.

### Naked Electrode

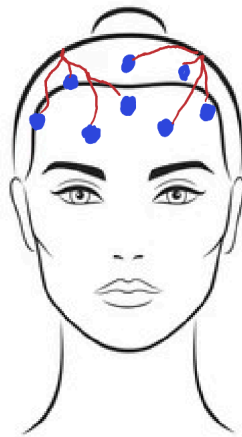

Figure 3: Naked Electrodes Head Cap Concept Drawing

A design without a head cap minimizes associated costs: the electrodes are placed directly on the scalp (Figure 3). However, ensuring correct electrode placement and stability is a significant hurdle. All anatomical landmarks must be correctly manually identified, and electrodes must be consistently placed between tests.

## 3D-printed Head Cap

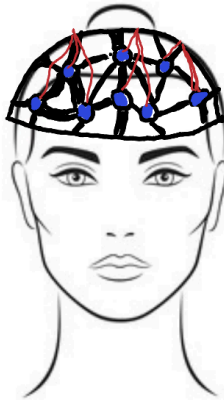

Figure 4: 3D Printed Head Cap Concept Drawing

The final proposed design is a 3D printed head cap building off an existing pipeline that takes a computed tomography scan and provides a 3D printable design with the standard 10-20 placement [10] (Figure 4). This design uses a mesh of flexible filament that helps to reliably find landmarks and gives open space for hair to be adjusted during electrode placement. Each cap uses about 21 grams of filament with support material excluded. It has been proven to work with thermoplastic polyurethane (TPU) [10], which has a Shore Hardness scale between 60A-77D and an approximate cost per gram of filament between \$0.30-\$0.80. This proposed design would consider alternative flexible filaments that cost less and attempt to build upon the design to minimize extra material used for supports.

### *Circuits*

In addition to selecting a head cap, a circuit is required to accurately acquire the brain's signals. The circuit must include components to filter the signal and sample the waves at a rate of 1kHz. Two proposed circuits met the criteria.

#### Single-channel Analog-to Digital Converter + Multiplexer

The first proposed circuit consisted of a single instrumentation amplifier (INA) connected to each electrode, which are then fed into a multiplexer (MUX) (Figure 5). It cycles through each signal, sending one at a time through to the microcontroller (MCU). There is an additional set of circuitry to further ready the signal for acquisition; all collected signals go through a single set of circuitry due to the multiplexer. The signal is then collected from the Analog-to-Digital Converter (ADC) onboard the MCU.



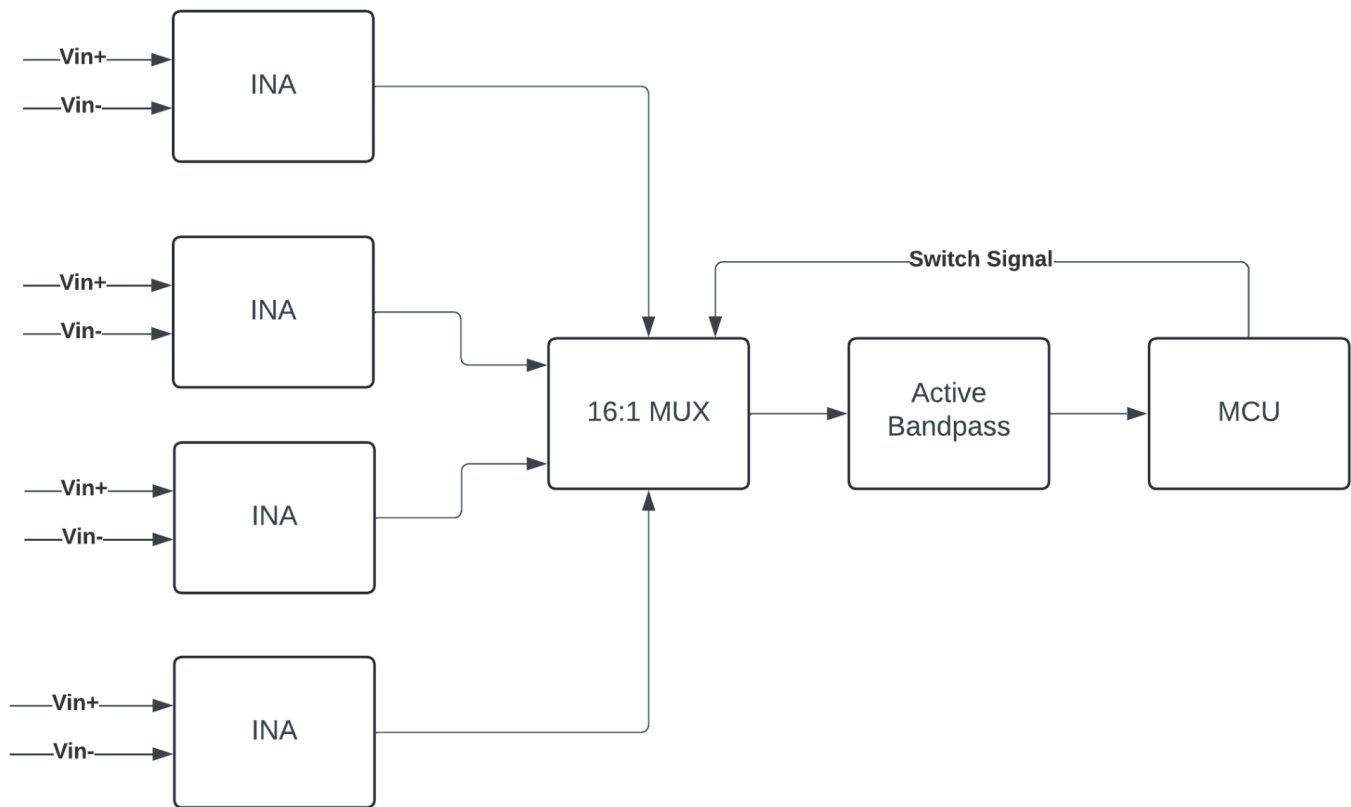

Figure 5: Circuit design with a single digital signal and multiplexer

### Multi-Channel Analog-to-Digital Converter

The second proposed circuit involves processing each individual signal through their dedicated instrumentation amplifiers and additional front-end circuitry (Figure 6). These signals are then collected by a multi-channel ADC. It connects to the microcontroller via serial communication, which can then process and display every signal. This process involves ten bandpass filters and ten level shifters (among other signal processing units) for each electrode, unlike the one detailed previously.

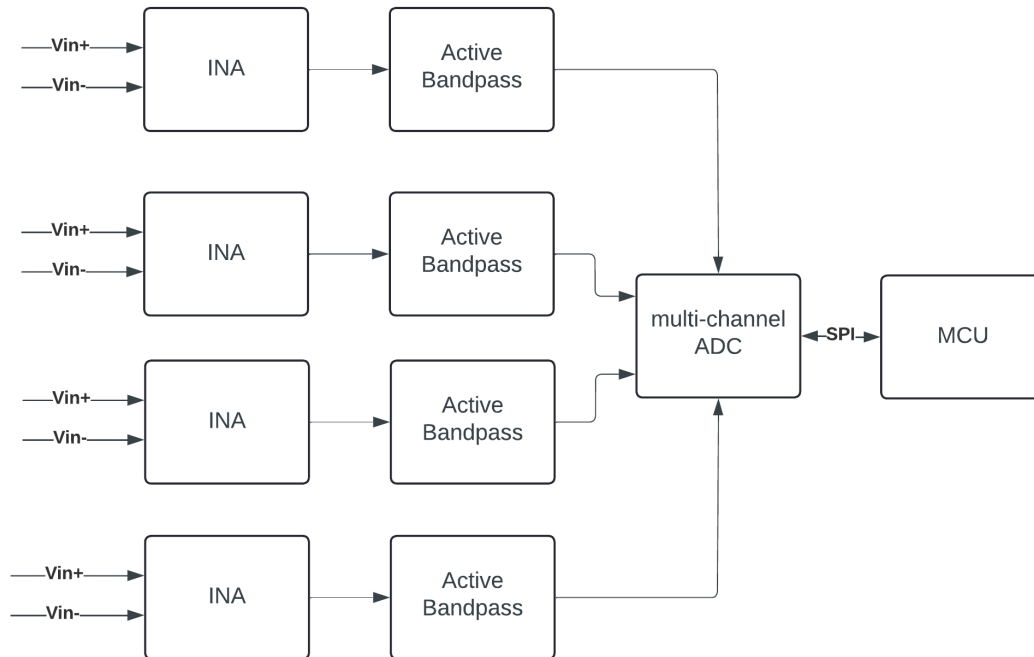

Figure 6: Multi Channel ADC Circuit Connected to Front End

## Preliminary Design Evaluation

### Proposed Final Head Cap Design

To evaluate the effectiveness of the proposed head cap designs, the following design matrix was proposed. Each design was rated on a scale between 0 and the weight of that category, where the maximum possible score for each design is 100. Each design was rated based on the overall cost of that solution, the safety for the person wearing the head cap, meaning electrodes were secure, how accurately each electrode would be placed on the standard 10-20 electrode markers, how repeatable the design is, meaning each time it was created it would have the identical dimensions and each time it was used given the same inputs it would provide the same outputs, ease of use for the person administering the test, how comfortable the design would be on the person receiving the test and finally how easy each would be to fabricate including either production, assembly or purchasing.

Table 1: Head Cap Design Matrix

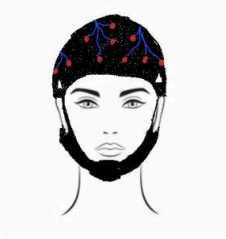
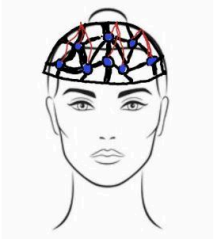
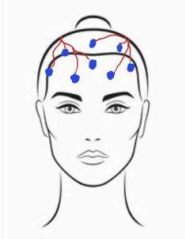
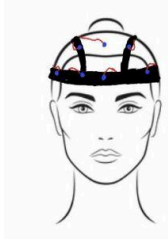
					
	Store Bought	3D Printed	No Head Cap	DIY	Weights
Cost	0	16	20	16	20
Safety	15	12	9	9	15
Accuracy	14	11	3	6	14
Repeatability	11	14	3	6	14
Ease of Use	13	10	5	5	13
Durability	12	7	10	5	12
Comfort	7	6	6	4	7
Ease of Fabrication	5	2	5	3	5
<b>Total</b>	<b>77</b>	<b>78</b>	<b>60</b>	<b>53</b>	100

While the Store Bought design did have the highest score in the majority of categories, due to the highest quality designs having a cost higher than the entire cost of this product, the 3D printed design was chosen to continue as the proposed final design. For more details see Appendix C.

### Circuits

A design matrix was also proposed to evaluate the various circuit designs. Similar to the head caps, a rating scale was created where a maximum of 100 could be achieved for each design. The designs were compared against one another in several categories, with the most weight being awarded to cost, as well as how accurate the signal collection would be. Other categories of rating included how easy it would be to fabricate the design, how difficult it would be to code the analysis and display of the signals, and how available the components would be for purchases; this includes how easy it is to swap one component for another readily available on the market. All of these categories were placed in the design matrix, as seen below in Table 2.

Table 2: Circuit Design Matrix

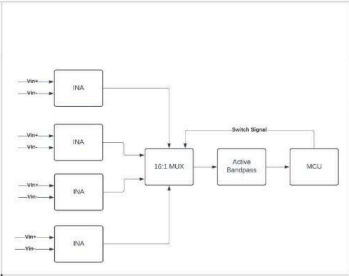
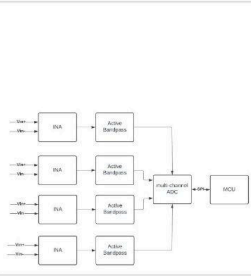
			
	<b>Single-channel ADC + MUX</b>	<b>Multi-channel ADC</b>	<b>Weights</b>
<b>Cost</b>	26	16	26
<b>Accuracy</b>	16	21	26
<b>Ease of fabrication</b>	20	15	25
<b>Firmware Complexity</b>	5	3	5
<b>Components Availability</b>	14	10	17
<b>Sum</b>	<b>81</b>	<b>65</b>	100

From the design matrix, it can be seen that the single channel ADC + MUX is the clear winner. The cost of this design is much less due to the decreased number of op amps, and because the reduced circuitry wins in both fabrication ease and component availability. It is also easier to code as there is only one signal, allowing for easier processing. The only category it loses in is accuracy, as it has to switch between 10 different signals. However, by allowing time for the signal to stabilize, disruptions in collection can be minimized, avoiding inaccurate readings. Thus, the single-channel ADC + MUX is the selected design to pursue. More information regarding the selection can be found in Appendix B.

## Fabrication

### Head Cap

#### Materials:

Proposed materials for 3D printing of the head cap include: TPU, soft polylactic acid (Soft PLA), thermoplastic polyamide (TPA), polyether block amide (PEBA), thermoplastic copolyester (TPC) and thermoplastic styrenic elastomer (TPS). These filaments range in price between \$0.05 to \$0.80 per gram of filament. Any full size head cap will take approximately 20 grams of filament, not including any supports. 3D printed head caps have been proven to work with TPU before [10], but experimenting with other filaments may give a lower cost, as well as trying to minimize or eliminate support material.

Table 3: Proposed Head Cap Filament Materials

Name	Cost (\$/gram)	Flexibility (Shore Hardness)	Printing Temp (deg C)
TPU	0.3-0.8	60A-77D	210-230
Soft PLA	0.12	92A	190-230
TPA / TPI	0.39	70A-95A	230-250
PEBA	0.16	75A-90A	240-260
TPC	0.052	95A	220-260
TPS	0.08	70A-90A	260-280

## Methods

Head cap design and production will follow many of the steps outlined in with a few key distinctions [10]. First, biometric analysis of head size will be done to find approximate CT sizes that will fit a set range of users; this can be used to create a Small, Medium and Large or as many sizes as needed. Also, post-processing of the stereolithography (STL) file in Blender (Blender Foundation, Amsterdam, Netherlands) or Solidworks (Dassault Systemes, Velizy-Villacoublay, France) will be completed to change the model in such a way as to minimize or eliminate support material. 3D printing will occur according to instructions for the specific printer model and recommended settings from the filament manufacturer and adjusted as needed for optimal results.

## Circuits

### Materials:

To complete the circuit, various components will be used to create the design. The MCP6N11-100 (Microchip Technology, Chandler, Arizona) will be used for an instrumentation amplifier, as it contains sufficient input impedance at a low price. The multiplexer used will be CD74HC4067M96 (Texas Instrument, Dallas, Texas), which allows for sampling of all signals at a 1kHz rate. The programmable operational amplifier LMH6515SQ will provide a way to control the gain of the entire circuit. The Raspberry Pi RP2040 (Raspberry Pi Foundation, Cambridge, England) provides a way to control the circuit, and also has 4 ADC on board. Bi-directional Zener Diodes ESD9B5.0ST5G (Onsemi, Phoenix, Arizona) will be utilized to allow for circuitry protection. The operational amplifier TL072CDR (Texas Instrument, Dallas, Texas) was a cheap option that provided the required functions necessary for a level shifter and a right leg driven circuit. Additionally, a microchip TC962EPA (Microchip Technology, Chandler, Arizona) will allow for DC-DC conversion to create a negative voltage. Finally, various resistors and capacitors will be purchased for the completion of the circuit. The total for these major components is \$30.73, with a cost breakdown provided in Appendix A.

Methods

A design will be completed in Altium Designer (Altium, San Diego, California) to start the creation of the circuit. This will allow for visualization of the entire circuit and an outline for the completed board. After the design is complete, the schematic will be sent to a company to print the circuit board. This method will cost approximately \$10, after which the board will be inspected to ensure it was printed accurately. The necessary pieces will be soldered into the board following this inspection to complete the assembly. After testing connections to ensure proper connectivity, the board can begin to be tested.

Final Prototype

The final prototype is not yet completed, however is in progress. The current Altium schematic of the prototype can be seen in Figure 7 below. This schematic will be finalized then sent off to be printed.

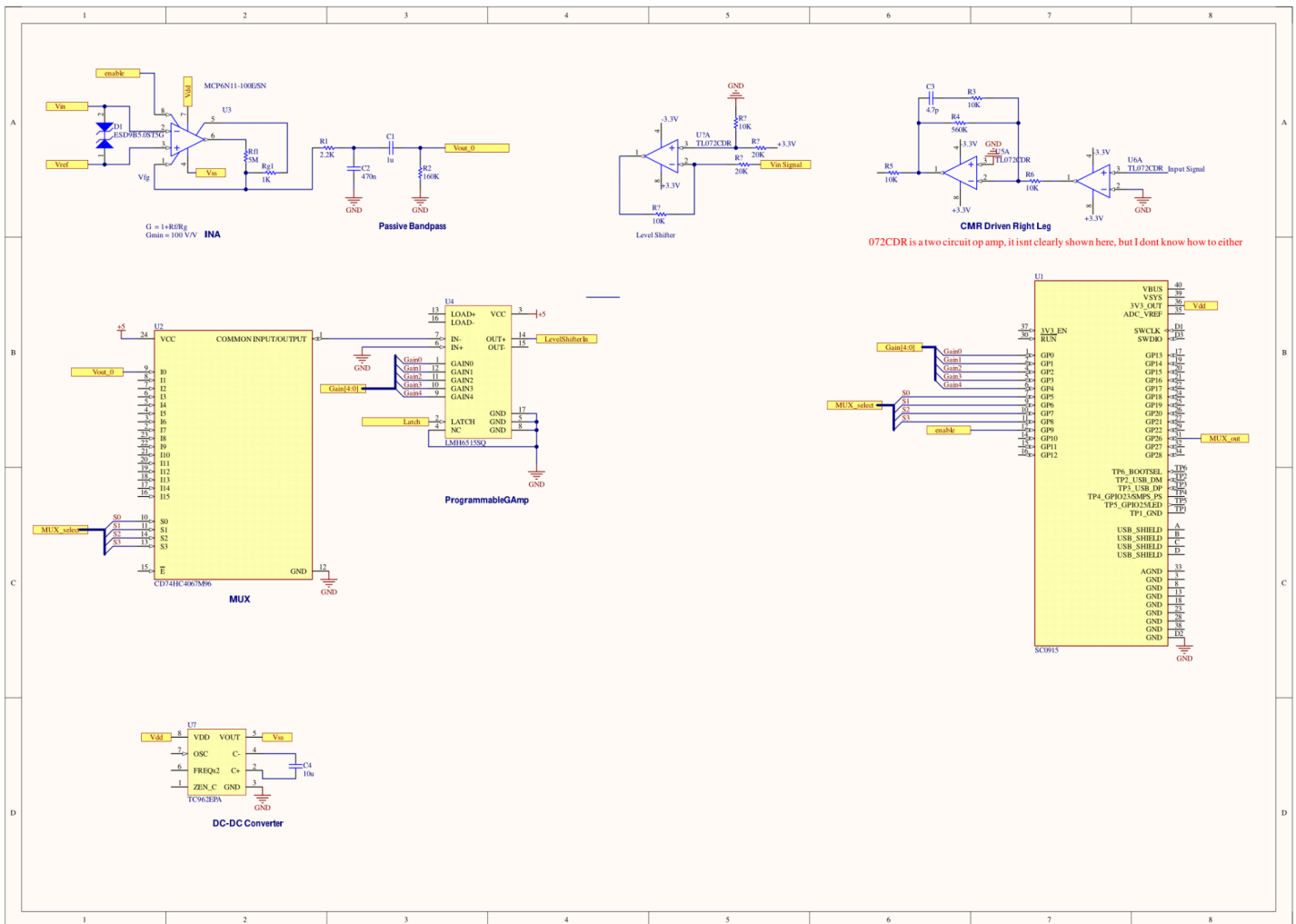

Figure 7: Proposed Schematic of the Analog Front End

## Testing and Results

The system's evaluation is divided into two sections: head cap evaluation and analog front end evaluation, which are conducted separately.

### Head Cap Evaluation

The evaluation of the head cap consists of two phases: comfort and spatial accuracy. Tests in both aspects are conducted with volunteers who are representative of targeted users. Notably, we seek participants with a maximum head circumference ranging from 50 to 64 cm [9], [11], typical of commercial EEG system limits, and with various hair volumes and textures [12].

### Comfort Assessment

The head cap is placed on the participant's head without electrodes attached. The participant is then asked to sit still for five minutes. At the end of the session, the participant fills out a survey rating each category out of five (Table 4). For True/False questions, the score is five for True and zero for False. The participants are asked for additional comments at the end of the survey.

Table 4: Proposed Comfort Assessment Survey

Category	Score
How secure does the head cap feel on your head?	
Were there sharp corners pressing against your head?	
How willing would you be to wear the head cap for another 30 minutes?	

### Spatial Accuracy Assessment

The spatial accuracy tests are conducted concurrently during the same session as the comfort assessment. It serves primarily as a qualitative assessment of the deviation between ideal electrode placement according to the international 10-20 system and the actual placement of the electrode on the head cap. Medical students are consulted to ensure that the placements are acceptable for clinical usage.

### Analog Front End Printed Circuit Board Evaluation

The assessment of the analog front end is divided into two sections. First, we ensure that the ports, power lines, and grounds are correctly connected and that the microcontroller can successfully control the gain of the programmable amplifier. Then, we quantify the quality of the signal and determine if further improvement is necessary.

## Functionality Check

Firstly, power is delivered to the microcontroller and the PCB via a USB cable. Then, the input electrode is connected to a 100  $\mu\text{V}$  peak-to-peak 40 Hz sinusoidal signal, typical of EEG signals [13], while the reference electrode is connected to ground. The microcontroller is then programmed to sample the output of the analog front end at a 1 kHz rate and reproduce the signal through the digital-to-analog converter (DAC) at the same rate. The DAC is then connected to an oscilloscope to verify that a signal resembling the input is observed.

## Signal Quality Quantification

### **Frequency Response**

The frequency response of the analog front end is calculated by connecting the input electrode to a 100  $\mu\text{V}$  peak-to-peak signal with various frequencies and calculating the output magnitude observed by the microcontroller. The frequency ranges from DC to 500 Hz at a resolution of 5 points per decade. The response is then plotted in a bode plot.

### **Signal-to-Noise Ratio (SNR)**

The electrodes are first placed on a non-conductive material, e.g., plastic, to collect the baseline noise signal. Then the electrodes are placed on the scalp of a subject according to standard EEG practice and a sample signal is recorded by the microcontroller. The power of the noise and signal are calculated by equation 1:

$$P_{signal} = \frac{1}{N} \sum_{i=1}^N (V_{signal,i})^2, \quad (1)$$

where  $P_{signal}$  is the power of the signal of interest,  $N$  is the number of samples, and  $V_{signal}$  is the magnitude of the signal of interest. Then the SNR is given by:

$$SNR(dB) = 10 \times \log_{10} \left( \frac{P_{signal}}{P_{noise}} \right). \quad (2)$$

### **Common Mode Rejection Ratio (CMRR)**

The input electrode is connected to a 100  $\mu\text{V}$  peak-to-peak 40 Hz sinusoidal signal, and an additional 60 Hz 10  $\mu\text{V}$  peak-to-peak noise is applied to both the input electrode and the reference. The magnitude of the common mode signal in the output signal is quantified through the Fourier transform. The CMRR is then calculated through equation 3:

$$CMRR(dB) = 20 \times \log_{10} \left( \frac{G_{differential}}{G_{common}} \right), \quad (3)$$

where  $G_{differential}$  and  $G_{common}$  refers to the differential mode gain and the common mode gain, respectively.



## Discussion

When looking at the results of the testing, it is important that the accuracy of the device is assured. This device should be low-cost to allow EEG's to be more widely available. However, this can not come at the expense of inaccurate data. While the acquired signals may not be as clean, they need to be able to accurately reflect the signals that are occurring within the brain. If, through testing, it is discovered that the signals are inaccurate, higher quality products must be invested in to allow for correct results.

When testing the circuit, there are several different sources of error that could contribute to inaccurate or faulty results. If components were improperly selected, or manufactured incorrectly, results could be skewed. If the board is printed incorrectly it will not function properly. There could be issues with human assembly, such as incomplete soldering resulting in a faulty connection. Tolerances of devices have the potential to pose a challenge, particularly due to the fact that cheaper items have a bigger tolerance for error. To minimize these effects, components will be tested individually for proper function and tolerances, particularly in the initial design stages. The boards will be carefully inspected after printing, as well as soldering, in an attempt to ensure proper connections prior to testing.

Testing of the device will need to be completed to ensure that the design of the device is accurate and effective. Following this extensive testing, another protocol will be created to aid individuals in testing the device on their own. This testing can be less intensive, as the device will be known to operate correctly. It will still have to include components to ensure that everything is hooked up correctly. By reducing the total amount of testing that is required, the device will be more accessible to hospitals in need. As many doctors do not have an extensive electrical background, simplifying the testing where possible will open up more opportunities to employ the product, as well as ensure confidence with the product, due to the fact that the doctors can comprehend the tests being conducted.

Ethical considerations also need to be taken into consideration when designing this product. This product needs to give consistent, dependable, and reliable results before being used clinically, as it deals with treating patients. This device should also pose no risk to the individuals using it; this includes both the test administrator as well as the patient themselves. Numerous tests will be conducted to ensure that safety measures are in place for possible events that could happen, including power surges and components failure. The patients must also have informed consent when using this device, which means that a document listing possible outcomes and giving accurate product information must be written up and provided to the patient. All of this will be done prior to connecting anyone to the device.

## Conclusions

In this work, we show the final design of an affordable diagnostic EEG system and its proposed fabrication and testing protocols. EEG is critical in the diagnosis and treatment of Epilepsy. Since 80% of epilepsy patients live in low- and middle-income countries [5], the majority of which do not have access to EEG systems or treatments, an affordable EEG system is essential. No product on the market, however, satisfies this critical need. The team presents a 3D-printed head cap with ten channels sampled in series via a multiplexer and is finalizing design details. PCB designs are mediated through Altium Designer (Altium, San Diego, California). Once printed, the team will complete the analog front end prototype according to the fabrication protocol outlined in this document and evaluate the prototype accordingly. The head cap designs are mediated through Blender (Blender Foundation, Amsterdam, Netherlands) and will similarly follow the fabrication and testing protocols outlined in the sections above.

## References

- [1] “About Epilepsy,” Epilepsy Alliance Ohio. Accessed: Oct. 09, 2024. [Online]. Available: <https://www.epilepsy-ohio.org/about-epilepsy/>
- [2] “Epilepsy Treatment | Epilepsy Foundation.” Accessed: Oct. 09, 2024. [Online]. Available: <https://www.epilepsy.com/treatment>
- [3] H. C. McLane *et al.*, “Availability, accessibility, and affordability of neurodiagnostic tests in 37 countries,” *Neurology*, vol. 85, no. 18, pp. 1614–1622, Nov. 2015, doi: 10.1212/WNL.0000000000002090.
- [4] “All-in-One EEG Electrode Cap Bundle,” OpenBCI Online Store. Accessed: Oct. 09, 2024. [Online]. Available: <https://shop.openbci.com/products/all-in-one-eeeg-electrode-cap-bundle>
- [5] “Epilepsy: a public health imperative.” Accessed: Oct. 07, 2024. [Online]. Available: <https://www.who.int/publications/i/item/epilepsy-a-public-health-imperative>
- [6] “The Anatomical Basis of Seizures - Epilepsy - NCBI Bookshelf.” Accessed: Oct. 09, 2024. [Online]. Available: <https://www.ncbi.nlm.nih.gov/books/NBK580614/>
- [7] “Determining your hat size, head circumference.” Accessed: Oct. 09, 2024. [Online]. Available: [https://www.bon-clic-bon-genre.us/content-how-to-determine-your-hat-size\\_0.htm](https://www.bon-clic-bon-genre.us/content-how-to-determine-your-hat-size_0.htm)
- [8] “chipstein - Homebrew Do-it-yourself EEG, EKG, and EMG.” Accessed: Oct. 09, 2024. [Online]. Available: <https://sites.google.com/site/chipstein/homebrew-do-it-yourself-eeeg-ekg-and-emg>
- [9] “EEG Electrode Cap Kit,” OpenBCI Online Store. Accessed: Oct. 07, 2024. [Online]. Available: <https://shop.openbci.com/products/openbci-eeeg-electrocap>
- [10] A. McCann, E. Xu, F.-Y. Yen, N. Joseph, and Q. Fang, “Creating anatomically-derived, standardized, customizable, and three-dimensional printable head caps for functional neuroimaging,” Aug. 30, 2024, *bioRxiv*. doi: 10.1101/2024.08.30.610386.
- [11] “EasyCap Standard EEG Cap (with Holders).” Accessed: Oct. 07, 2024. [Online]. Available: <https://shop.neurospec.com/easycap-standard-eeeg-cap-with-holders>
- [12] S. N. Moody *et al.*, “Impact of hair type, hair sample weight, external hair exposures, and race on cumulative hair cortisol,” *Psychoneuroendocrinology*, vol. 142, p. 105805, Aug. 2022, doi: 10.1016/j.psyneuen.2022.105805.
- [13] J. G. Webster, *Medical Instrumentation Application and Design, 4th Edition*. John Wiley & Sons, Incorporated, 2009.

## Appendix

### A: Material Cost Summary

Component	Manufacturer	Manufacturer Part#	Cost Each	QTY	Total
Instrumentation Amplifier	Microchip Technology	MCP6N11-100	1.76	10	17.6
Multiplexer	Texas Instrument	CD74HC4067M96	0.66	1	0.66
Programmable Operational Amplifier	Texas Instrument	LMH6515SQ	2.78	1	2.78
Microcontroller	Raspberry Pi	RP2040	4	1	4
Protection Circuit	Texas Instrument	TPD13S523PWR	0.71	1	0.71
Operational Amplifier	Texas Instrument	TL072CDR	0.3	2	0.6
DC-DC convertor	Microchip Technology	TC962EPA	4.09	1	4.09
				<b>Total</b>	30.44

## **B: Product Design Specifications**

### **Function**

Epilepsy is a common chronic neurological disease characterized by abiding recurrent seizures [1]. The most recent WHO report cites 50 million people affected worldwide, whose risk of premature death is up to three times that of the general population [2]. Electroencephalogram (EEG) is the most widely used detection and analysis procedure for epilepsy, which records cortical electrical activity. Identifying EEG patterns and seizure foci is critical for the diagnosis of specific epilepsy syndromes and, consequently, the selection of appropriate therapy [3]. However, 80% of epilepsy patients live in low- and middle-income countries, the majority of which do not have access to EEG systems or treatments [2]. Therefore, affordable EEG systems that can be rapidly and broadly deployed are in critical need.

### **Client requirements**

- A single-channel sampling rate of at least 1 kHz.
- 12- to 16-bit analog-to-digital converter resolution.
- Periodic reading of electrode impedance to detect improper electrode contact.
- Total system cost at or below \$100.
- 10-channel analog frontend.
- Driven by wall-plugged power supply.

### **Design requirements**

### **Physical and Operational Characteristics**

#### **Performance requirements**

The devices will be used for 20 to 40 minutes per patient per procedure [4]. The frequency of usage is dependent on the medical facility.

#### **Safety**

The device must be sanitized between uses, and the skin contact electrodes must be replaced. Since the device involves prolonged skin contact, irritation, discomfort, and allergic reactions are possible. The device consists of active electrical components and wires; thus, it must be carefully handled and not be tampered with while powered on. Furthermore, the device's temperature during operation must not exceed 40 °C.

#### **Accuracy and Reliability**

The system should have a sampling rate of at least 1 kHz per client's requirement. The analog-to-digital converter (ADC) should encode with at least a 12-bit resolution to capture finer details of the EEG waveform. Low impedance, e.g., 5 k $\Omega$  electrodes, should be used to enhance signal clarity. To improve ease of use, the device should detect improperly connected electrodes. Additionally, signal filtering is required to reduce capacitive coupling effects from power lines and electromyogram interference. Typically, the reliability of a

diagnostic system is measured by its positive predictive value; however, the accuracy of epilepsy classification is critically dependent on monitoring duration and is unrealistic to calculate within the scope of this project [5].

### Life in Service

The system must remain operational for 3-4 years with proper daily usage, ensuring durability and consistent performance. It should function effectively within a temperature range of 0-40°C without any drop-off in EEG signal amplitude, as higher temperatures are observed to negatively affect signal quality in existing EEG systems [6]. Additionally, the system must be easy to clean between uses, as it will be exposed to various cleaning products. The head cap should remain functional for 3-4 years with daily cleaning.

### Shelf Life

The product should maintain its integrity and functionality in storage for at least ten years at room temperature. It must withstand transportation without any wear or damage and be designed to endure harsh conditions during transit. The product should tolerate storage temperatures ranging from -20°C to 100°C, as it may encounter extreme environments during transportation.

### Operating Environment

The EEG cap must ensure consistent and secure contact between the electrodes and the scalp to accurately capture brain signals while maintaining user comfort over extended periods. The materials should be soft, lightweight, and non-invasive, providing a secure yet non-irritating fit. The EEG system should also function reliably in various temperatures typical of indoor and controlled outdoor environments, e.g., 0-40°C. The cap and circuit board should resist sweat, moisture, and mild physical impacts, ensuring long-term durability and accurate signal collection.

### Ergonomics

The system should be accurate and fit users with a maximum horizontal head circumference between 50 to 64 cm, similar to other commercially available EEG electrode caps [7, 8]. The system should be effective for users of any hair volume and texture between bald and hair type 1 to 4d [9].



*Figure 1. Examples of hair types*

### Size

The entire system should be portable and easy to carry. The cap and electrodes should be able to fit on most children and adults.

### Weight

The system should weigh less than 1 lb and cause no neck strain while wearing.

### Materials

There are no printed circuit board (PCB) materials restrictions as the device is not intended to operate in extreme environments. Operating temperatures, coefficient of thermal expansion, and electrical characteristics are non-critical factors. Dry electrodes are preferred, typically composed of conductive silicone or gold-plated electrodes, as requested by the client [10]. The head cap should resist cleaning solutions, e.g., ethyl or isopropyl alcohol and chlorine-releasing agents.

### Aesthetics, Appearance, and Finish

The cap's design will ensure the patient feels comfortable in the environment. All wires should be as enclosed as the system allows. The circuit board will have a cover to shield the view from the patient. The appearance will be sleek and neutral to avoid any strong aversions. The appearance of the electrodes and the board will be professional in portraying the device's safety.

### Production Characteristics

### Quantity

One unit is needed for the scope of this project. This unit should be created to be reproducible on a large scale.

### Target Product Cost

For one unit, the entire system costs at or below \$100.

### Miscellaneous

#### Standards and Specifications

The Code of Federal Regulations Title 21, Volume 8 Chapter 1 Part 882: Neurological Devices provides specific standards concerning electroencephalograms (EEGs) and other commercially distributed neurological devices intended for humans. Sec. 882.1400 states that EEGs are used to measure and record the brain's electrical activity and are classified as a class II medical device [11]. This means they have to follow general regulatory control and special controls, including performance standards, special labeling requirements, and post-market surveillance [12]. They must also go through the 510(k), a premarket submission process that proves the device is similar to one currently operating and showcases that it is safe [13]. To be considered within this classification, the EEG can have recording hardware, monitor, and basic software; however, this does not include electrodes, a complex software analysis system (to either auto-detect or analyze events), or a system with more than 16 electrodes. Additionally, this device is not allowed to be used in sleep studies. EEG electrode/lead tester is a device used to test the impedance of electrodes. It is classified as a Class I device, along with an EEG signal spectrum analyzer and an EEG test signal generator. Cutaneous electrodes are applied directly to the skin to record or apply electrical stimulation and are classified as a Class II medical device.

In addition to FDA standards, IEEE recommended practice for EEG Neurofeedback Systems details practices that should be abided by [14]. The system must adhere to the IEC 60601-1 Safety and Essential Performance standard to follow safety procedures. The EEG should be sold as a medical device, where the user is trained to operate the equipment properly. System software shall be available to allow all parts of the system to be analyzed as needed. This includes electrodes, which should have an expected lifetime, performance, polarization rate, and long-term stability. Cleaning techniques, application, and impedance checking should accompany these electrodes. Several different specifications should be included for the primary component, as listed in Table 1.

Along with these documents, several ISO and IEC standards are applicable. IEC standard 80601-2-26:2019 details the particular requirements for EEGs' basic safety and performance [15]. ISO standard 22077-5:2021 specifies the format of waveforms created during EEG to support one recording session [16].

***Table 1: Specifications that must be listed, as stated by IEEE Recommended Practice for EEG [14]***

Amplifier Specifications	Frequency specifications	Analog to Digital Conversion
Input impedance	Magnitude response	Number of bits, number of channels, and type input/output channel
DC/AC coupling (time constant if ac coupled)	Phase response	Sampling rate
Noise/sensitivity (RMS and/or peak-peak voltage, given bandwidth or application, noise spectrum)	Corner frequency / frequencies	Anti-aliasing filter specification
Signal input range	Decay and rolloff	Resolution, quantization error, and/or least-sig bit size (eg performance over temperature, hysteresis, etc.)
Signal output range	Decibel (dB) attenuation in stopband	ADC technique
Ground type (active/not) or direct reference line noise		Channel-to-channel isolation and digital channel
CMRR		
Gain		
Bandwidth		
Supply voltage/current consumption		
Impedance checking specifications (stimulus, measurement time/duration, absolute accuracy, relative accuracy)		
Amplification		

## Customer

The device is tailored for medical clinics in underdeveloped areas; thus, its cost and durability are prioritized. Both criteria are detailed in this document above. Additionally, the device should be intuitive to use and include detailed instructions in various languages.

## Patient-related concerns

Four main patient-related concerns will be addressed:

- **Patient Comfort & Skin Irritation:** Long-term EEG monitoring may cause discomfort or skin irritation, especially due to the electrodes' contact with the scalp. Proper cap design, skin preparation, and using hypoallergenic materials are essential to reduce discomfort and prevent rashes or sores.
- **Movement Restrictions:** Patients must remain relatively still during EEG recording to avoid artifacts from muscle movements. This can be challenging, especially for pediatric or uncooperative patients, leading to inaccurate readings.
- **Infection Risk & Hygiene:** Reusing EEG caps and electrodes poses a risk of infection if they are not properly sanitized between uses. Ensuring strict hygiene protocols and using disposable components when necessary can mitigate this risk.



- **Psychological Stress or Anxiety** Some patients, particularly children or those with certain neurological conditions, may experience anxiety or discomfort during the EEG process due to unfamiliar equipment or the need to remain still for extended periods. Clear communication and a calming environment can help alleviate these concerns.

## Competition

Most EEG systems are intended for medical use and are inaccessible to consumers and medical facilities in underdeveloped countries. Although consumer EEG systems with relatively low costs exist, none of the multi-channel systems cost close to the \$100 threshold (Table 2). Commercialized products like Neurosky, Muse, and Emotiv often feature non-essential Bluetooth functionalities and auxiliary sensors that contribute to their cost. Their channel count and sampling rate also fall short of the client's requirements. Open EEG's modular EEG system offers the most competitive pricing for its performance. However, its ATmega8 employs a 10-bit ADC with six channels that fail to meet the performance requirements.

*Table 2: Summary of Existing Consumer EEG Devices*

Product	Channel Count	Sampling Rate (Hz)	Bit Depth	Wireless	Cost (USD)
Neurosky MindWave	1	512	12	Yes	130
Muse2	4	256	12	Yes	300
Emotiv MN8	2	128	14	Yes	400
Emotiv Insight	5	128	16	Yes	500
Emotiv EPOC X	14	256	14-16	Yes	1000
Emotiv Flex Saline	32	256	16	Yes	2000
Open BCI Complete Kit	16	125	24	No	2500
Open EEG	2-6	Up to 15.4k	10	No	200-400





## Reference

- [1] E. Beghi, "The epidemiology of Epilepsy," *Neuroepidemiology*, vol. 54, no. 2, pp. 185–191, Dec. 2019. doi:10.1159/000503831
- [2] *Epilepsy: A Public Health Imperative*. Geneva: World Health Organization, 2019.
- [3] S. Noachtar and J. Rémi, "The role of EEG in epilepsy: A critical review," *Epilepsy & Behavior*, vol. 15, no. 1, pp. 22–33, May 2009. doi:10.1016/j.yebeh.2009.02.035
- [4] S. C. Schachter, "EEG procedure," Epilepsy Foundation, <https://www.epilepsy.com/diagnosis/eeg/procedure> (accessed Sep. 19, 2024).
- [5] G. S. Drenthen et al., "Predictive value of functional MRI and EEG in epilepsy diagnosis after a first seizure," *Epilepsy & Behavior*, vol. 115, p. 107651, Feb. 2021. doi:10.1016/j.yebeh.2020.107651
- [6] C. de Labra, J. L. Pardo-Vazquez, J. Cudeiro, and C. Rivadulla, "Hyperthermia-induced changes in EEG of anesthetized mice subjected to passive heat exposure," *Frontiers in Systems Neuroscience*, vol. 15, Sep. 2021. doi:10.3389/fnsys.2021.709337

- [7] NEUROSPEC, “EasyCap Standard EEG Cap (with Holders).” Accessed: Sep. 18, 2024. [Online]. Available:  
[https://shop.neurospec.com/easycap-standard-eeeg-cap-with-holders?\\_\\_store=en\\_US&\\_\\_from\\_store=x\\_default](https://shop.neurospec.com/easycap-standard-eeeg-cap-with-holders?__store=en_US&__from_store=x_default)
- [8] OPENBCI, “EEG Electrode Cap Kit.” Accessed: Sep. 18, 2024. [Online]. Available:  
<https://shop.openbci.com/products/openbci-eeeg-electrocap>
- [9] S. N. Moody et al., “Impact of hair type, hair sample weight, external hair exposures, and race on cumulative hair cortisol,” *Psychoneuroendocrinology*, vol. 142, p. 105805, Aug. 2022, doi: 10.1016/j.psyneuen.2022.105805.
- [10] G. Di Flumeri et al., “The dry revolution: Evaluation of three different EEG dry electrode types in terms of signal spectral features, mental states classification and usability,” *Sensors*, vol. 19, no. 6, p. 1365, Mar. 2019. doi:10.3390/s19061365
- [11] 21 CFR § 882.1400, Code of Federal Regulations, U.S. Government Publishing Office, 2014
- [12] Center for Devices and Radiological Health, “Regulatory controls,” U.S. Food and Drug Administration,  
<https://www.fda.gov/medical-devices/overview-device-regulation/regulatory-controls#:~:text=Special%20controls%20are%20regulatory%20requirements,Guidelines> (accessed Sep. 19, 2024).
- [13] Center for Devices and Radiological Health, “Learn if a medical device has been cleared by FDA for marketing,” U.S. Food and Drug Administration,  
[https://www.fda.gov/medical-devices/consumers-medical-devices/learn-if-medical-device-has-been-cleared-fda-marketing#:~:text=Section%20510\(k\)%20of%20the,manufacturer%20can%20market%20the%20device](https://www.fda.gov/medical-devices/consumers-medical-devices/learn-if-medical-device-has-been-cleared-fda-marketing#:~:text=Section%20510(k)%20of%20the,manufacturer%20can%20market%20the%20device) (accessed Sep. 19, 2024).
- [14] IEEE recommended practice for electroencephalography (EEG) neurofeedback systems.  
doi:10.1109/ieeestd.2023.10186304
- [15] Medical electrical equipment – Part 2-26: Particular requirements for the basic safety and essential performance of electroencephalographs, IEC 80601-2-26, International Electrotechnical Commission, 2019.
- [16] Health informatics — Medical waveform format — Part 5: Encoder for SCP-ECG, ISO/TS 22077-5, International Organization for Standardization, Geneva, Switzerland, 2021.

## C: Design Matrix

### Electrode Cap

	Store Bought		3D Print		No Head Cap		DIY		
									
	Points out of 5	Weighted Score							Weight
<b>Cost</b>	0	0	4	80	5	100	4	80	<b>20</b>
<b>Safety</b>	5	75	4	60	3	45	3	45	<b>15</b>
<b>Accuracy</b>	5	70	4	56	1	14	2	28	<b>14</b>
<b>Repeatability</b>	4	56	5	70	1	14	2	28	<b>14</b>
<b>Ease of Use</b>	5	65	4	52	2	26	2	26	<b>13</b>
<b>Durability</b>	5	60	3	36	4	48	2	24	<b>12</b>
<b>Comfort</b>	5	35	4	28	4	28	3	21	<b>7</b>
<b>Ease of fabrication</b>	5	25	2	10	5	25	3	15	<b>5</b>
<b>Total</b>		<b>386</b>		<b>392</b>		<b>300</b>		<b>267</b>	<b>100</b>

Cost:

The expected cost to produce one electrode cap. Store Bought is by far the most expensive, with most models being well over \$100, No Head Cap requires no additional material so is therefore the cheapest. DIY and 3D Print have the potential to be inexpensive depending on material choice, but do have some cost associated with them.

Safety:

All electrode caps should be safe for use and provide stable electrode connection, while none of these designs provide major risk, Store Bought was most safe since it provides the most protection between the electrodes and head while other designs may be at higher risk for electrodes to come loose.

Accuracy:

The electrode cap design must keep each electrode accurately at the associated biological marker. Store bought was ranked the most accurate since with more material covering the head, strain to cause electrode drift to incorrect locations is minimized by more material. No head cap is the least accurate since it requires the Doctor to place electrodes manually before each test.

Repeatability:

## BME 400

The design must be able to be constructed and run repeatedly with no dip in performance of the product. The environment, patient, and the person running the test are all factors that could change. Despite these changes, the results should remain consistently accurate. The 3D printed design was ranked the highest because the team would have control over the production of each component unlike the store bought. The no head cap and DIY both ranked lower as these have a much higher chance of human error leading to less accurate results over multiple trials.

### Ease of Use:

Ease of use refers to the difficulty for the tester to run the test on the patient. This product needs to be fairly easy to use so that a trained operator can consistently give the test and the patient has no issues during the test. The store bought design ranked highest because the commercial products are tailored to the interest of the consumer, giving it a good chance to be easy to use. The DIY and no head cap ranked lowest as these would require a lot more training on how to create/execute the test.

### Durability:

This design must be durable in order to withstand travel, repeated use, and movement as the patient adjusts the product in order to fit the cap to their head. The store bought design was ranked the highest as since these are commercially available, the quality of the product will most likely be higher than our other design ideas. The no head cap scored higher on this metric as there is not much that could be damaged to the product itself. While the DIY and 3D printed designs have a higher chance of human error as well as a design tailored to performance and not durability.

### Comfort:

The design must be comfortable enough for the patient to get through the test without any difficulties but the team decided this was not of top priority due to the importance of other factors. The store bought design ranked the highest amongst this metric as since those are typically more expensive the company creating the design has put more effort into the comfort of the product than our other designs. The DIY ranked the lowest as this design would be very simplistic and tailored towards accomplishing the task of running the test accurately without a focus on comfort.

### Ease of fabrication:

Ease of fabrication was not weighted as highly as other factors due to most of these products being easy to assemble. The 3D printed design ranks the lowest as this would be the most difficult to fabricate due to the size and structure of the cap itself. The store bought would be easily fabricated as there would be no assembly, the cap would arrive fabricated.

***Electronics***

	<b>Single-channel ADC + MUX</b>	<b>Multi-channel ADC</b>	<b>Weights</b>
<b>Cost</b>	26	16	26
<b>Accuracy</b>	16	21	26
<b>Ease of fabrication</b>	20	15	25
<b>Firmware Complexity</b>	5	3	5
<b>Components Availability</b>	14	10	17
<b>Sum</b>	<b>81</b>	<b>65</b>	100

Cost:

Cost is defined as the listed price of the component on Digikey. The cost for creating the single-channel ADC + MUX costs less to produce, as the multi-channel ADC costs significantly more than the single channel ADC.

Accuracy:

Accuracy is defined as the amount of noise contributed by the individual component. There are less components in the multi-channel ADC, so there is less probability of noise being created. However, neither circuit was given a 5, as the components will generate some amount of noise. This will particularly be true due to the low cost objective; more noise will likely enter the signal acquisition as a result of using cheaper components.

Ease of fabrication:

Ease of fabrication is defined as the amount of time and effort that it takes for the team to fully assemble the system, e.g., soldering, PCB designs. The multi-channel ADC has less individual components, so it will be easier to fabricate.

Firmware Complexity:

Firmware complexity is defined as the associated coding and wiring complexity. The multi-channel ADC received a higher score because of the ease of coding. Creating the code to alternate through each electrode channel is more difficult than reading all of the separate signals at once.

Component Availability:

Components availability is defined as the number of equivalent components available on Digikey. Equivalency refers to the ability of the component being swapped without changes to other components. There are more equivalent swaps for the creation of the single channel circuit, so it was given a higher rating.