

## Introduction

Our client this semester is Dr. Daniel Muller from the Institute of Aging in the Mind Body Center. Dr. Muller has been working with meditation and its medicinal uses for over 30 years, and meditation is one of his main fields of study. Meditation is a proven alternative medicine and is effective in combating diseases such as epilepsy, mood disorders, addictions, and it is a stress reducer as well (Gaudet, 1998).

Meditation involves one altering their state of mind, so it can be quantized by brain waves. As seen in figure 1, the brain is in one of four states at any given time.

When designing our device, we will be primarily concerned only with alpha and theta

brain states. Alpha

brain waves

correspond to the state

of mind where one is

relaxed but awake.

This is the mind state

one would be in when

one was attempting to

meditate, but had not

reached a meditative

state yet. Theta waves

correspond to the

brain state one is in

when one has achieved a meditative state (Anderson et al, 2005). Also, notice the

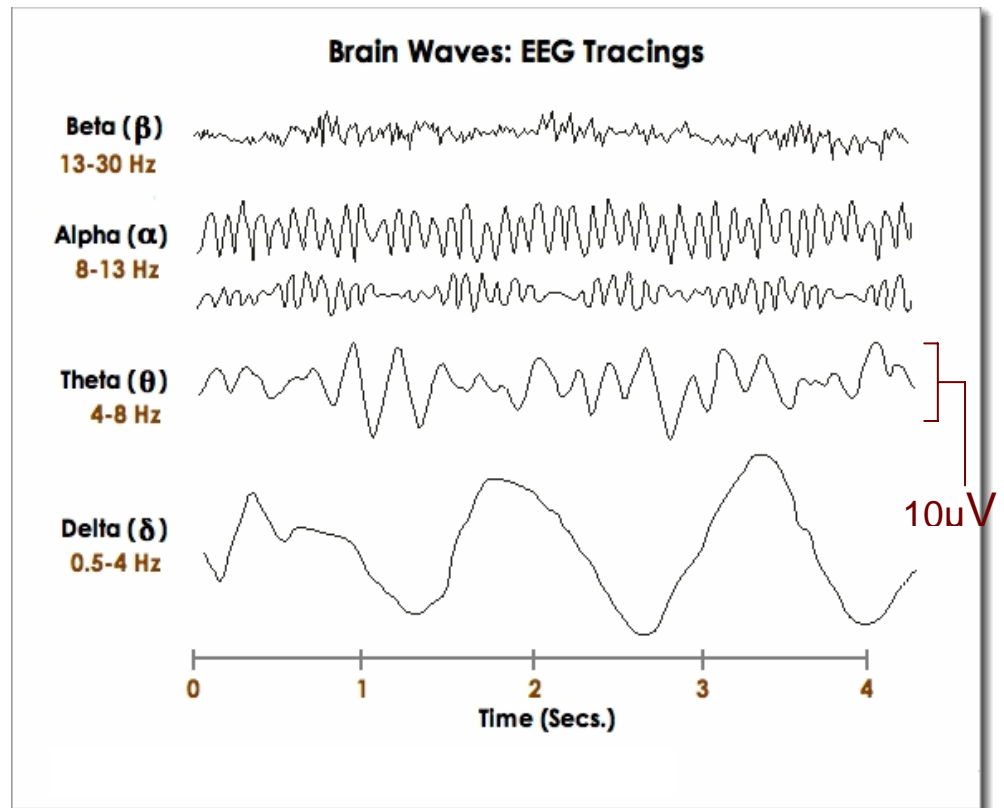

*Figure 1: EEG signals of four different brain states.* Above is an EEG of four different states the brain can be in at any given time. Notice the amplitude of the waves is 10 microvolts.

frequencies of the alpha and theta waves; 8 to 13 Hz and 4 to 8 Hz, respectively. These are the frequencies that our filters have been constructed to pass. The amplitude of the brain waves is on the order of 100  $\mu\text{V}$ ; another important design specification for amplification.

The problem that our client presents to us is this; meditation is a learned practice so it is inherently difficult to master without some sort of feedback. Feedback would tell the person trying to meditate what state of mind they are in, and how close to a meditative state they are. Our client would like us to design and construct a device that would detect a person's brain state by measuring brain waves with electrodes. Then, the brain waves would be selectively filtered and amplified eliminating any noise. Lastly, the brain wave would be turned into some sort of biofeedback signal, such as a light or a sound to notify the user what brain state they are in, alpha or theta, and how close to meditation they are. This semester, we chose to put all of our focus on the amplification and filtering stage the device.

## **History**

The biofeedback and stress management project has been active for the last five years. Overall, there have been three main goals, namely, signal acquisition, amplification/filtering, and feedback. Previous work has primarily involved similar design components including: electrodes, amplifiers, filters, rectifiers, averagers, and voltage controlled oscillators.

The signal acquisition phase involves electrode type, quantity, and placement. Electrode types have included disposable, reusable, and active/dry electrodes (contain electrical components) (Fielala, 2000). Most groups have found self-made reusable

electrode systems to be most affordable and versatile in terms of electrode position and user cranium size. The first electrode system in Fall 1999 involved dual (horizontal-vertical) head-straps and multiple slits for variable electrode positions (Kane, 1999). Subsequent groups have developed similar systems and additionally have proposed multiple electrode probes (Jain et. al 1976). Most recently, in the Fall 2005, the electrode system involved earplugs (soaked with 2% NaCl solution) fitted over the end of silver wire (Gaudet, 1998). There were three electrodes with positions at C3, C4, CZ, which were based on the 10-20 international system for electrode placement (Gaudet, 1998). Previous teams have utilized quantities ranging from 3 to 5 electrodes with one being a ground electrode (Gaudet, 1998). Decisions of electrode quantity and placement have been made by the evaluation of desired circuit simplicity and the target signal frequencies.

The second phase of the project is amplification and filtering. Most of the previous teams have cited two amplifier designs that were incorporated into their circuits. The first amplifier design was from “Amplifier Design with a Minimal Number of Parts” by A. C. MettingVanRijn, et al. This design proposed an amplifier with high Common Mode Rejection Ratio (CMRR), minimal part count, and reduced power consumption (MettingVanRijn, et al, 1994). This amplifier design was ideal for most groups that desired battery operation and portability. The second amplifier design was a basic instrumentation amplifier (MettingVanRijn, et al, 1994). This instrumentation amplifier had the advantage of having greater gain (signal amplitude), but at the expense of increased power consumption. This increased power use could potentially cause issues with battery utilization. By this, it is meant that increased power consumption by the device might limit the size and type of batteries used, due to differences in supply

voltages. Proposed amplifier gains in previous years have ranged from 15,000 to 100,000 (Kane, 1999) and this gain depends upon the circuit elements and their configuration. For filtering, most of the earlier groups used first or second order band-pass filters and later groups pursued digital signal processing to isolate the frequencies of interest. The main difference between the response of these two filter types is the steepness or slope of the transition from high to low response (output voltage). A higher slope means a steeper transition and better attenuation of unwanted frequencies and hence more effective filtering. By maximizing the removal of undesired frequencies, the output is made more accurate, because the undesired frequencies will not contribute as much to the response due to filtering. The second order response exhibits a steeper transition than that of the first order. The consequence of using the second order filter is the increased complexity of the circuit and potential increase in the number of parts. Another method of increasing filtering effectiveness is to utilize digital processing. The advantages of digital processing includes greater control and versatility, but consequently much greater complexity, cost, and time for development. Citations were made to a band-pass filter design and digital signal processing techniques from “A Spectrum Analyzer for EEG Signals” by V. K. Jain and A. Agarwal (Anderson, et al, 2005).

The final phase of the project is feedback. Previous groups have sought two types of feedback, namely, auditory and visual. Some groups used one or both, giving the user an option with the reasoning being that some may find one type of feedback more distracting than the other (Kane, 1999). Some designs have even provided feedback to outside observers, who may be monitoring the meditator (Kane, 1999). Most feedback processes in the past have been real-time or continuous meaning that the user always had

some indication of their status. Auditory feedback has been achieved through the change in pitch (frequency) or volume (Kane, 1999). It was deemed much easier for the human ear to discern changes in pitch rather than in volume (Kane, 1999). Visual feedback has been attained through the use of light emitting diodes (LEDs), where light intensity or color would be indicative of meditation status (Jain, et al, 1976). Pre-selection of a desired brain state has been used by a majority of the previous groups for circuit simplicity. This pre-selection would involve rotating a dial or altering a switch to the brain state one was training for (i.e., alpha or theta). Some common challenges faced by the previous teams include weak signals due either to electrode selection and/or to poor contact with the scalp through hair, difficulties with auditory feedback in that the sound response was sometimes distracting to the person meditating, low and high frequency interference, and signal baseline drift. The main challenge has been signal interference resulting in complications during testing. Due to the presence of high amplitude and low frequency interference, the signal arising from the brain activity cannot be clearly defined. The feedback can be erroneous due to this high amplitude/low frequency interference due to unwarranted triggering of the threshold level (i.e., amplitude at which the given frequency range (brain wave type) is deemed dominant).

### **Client Specifications**

Our client, Dr. Muller, has proposed the following desired device characteristics. The device is to be intended for recreational (non-clinical) use to aid those learning how to meditate. The device should therefore provide some sort of feedback to the user to indicate the progress of the meditation. The device should not be overly expensive and should be easily transportable (i.e., lightweight and small overall size). The ultimate goal

of the device would be to help the learning meditator to the point where the biofeedback would be unnecessary for the user to meditate effectively (i.e., after training with the device, the user would know how they should feel in the meditative state, where theta brain waves are predominant).

### **Device Parameters**

With the main goal of achieving the aforementioned specifications, our focus on filtering and amplification necessitated several circuit characteristics. Desired amplification parameters included high gain, high CMRR, and minimal number of parts. Gain is the factor by which the input is increased at the output. Gain is also affected by the circuit elements used in the amplifier. A relatively high gain is desired so that the output signal is easier to monitor with an oscilloscope. Gain alone is not that helpful if the common interference is also amplified, therefore a high Common Mode Rejection Ratio (CMRR) is also desired for the amplifier. If CMRR is high, then one can be assured that the gain is applied primarily to the target input signal (i.e., from the brain) and not from other sources (i.e., electrical equipment). In this case, the higher the CMRR, the more accurate the measurement. Normal brain signals can range from 10 – 100  $\mu\text{V}$  in amplitude (Kane, 1999). Amplification of these signals by 100,000 would result in an output voltage between 1 – 10 V. An output voltage above this would not be desired, because such amplification could result in amplifier saturation. Saturation occurs when the output is greater than the input power supply to the amplifier. In this case, the input supply was 15V, therefore an output above 10V would approach saturation. When viewing the response with an oscilloscope, saturation is easily seen by truncation of the signal amplitude at the saturation level. Minimal number of parts ties into device

portability, specifically in size and weight. A heavy and bulky device would not at all be easily portable by the user and might even distract the user during device operation. A high part count can also increase the power usage of the device. Desired filter parameters include the incorporation of band-pass filters (combination of low-pass and high-pass filters) to isolate the brain state frequencies and to remove interferences. For this project, the brain state frequencies of interest include alpha (relaxed) ranging from 8 – 13 Hz and theta (meditation) ranging from 4 – 8 Hz.

### **Design circuit components**

In order to achieve the design specifications, our circuit will be composed of three sections: preliminary amplification, filtering, and main amplification.

#### *Preliminary amplification*

The purpose of this section is to amplify the voltages measured by the electrodes so we can manipulate the voltage without distorting/eliminating the signals. To achieve this, we considered using differential amplifiers with a gain of 25. The limit for preliminary amplification is set at the gain of 25 to avoid saturation of the operational amplifiers (typically  $\sim 13\text{V}$ ) because of the possible DC-offsets (re-positioning of signal baseline due to the presence of a DC voltage). The DC-offsets can occur at the maximum of  $0.3\text{V}$ ; with gain of 25, the amplification would bring the DC-offsets to  $7.5\text{V}$  — a value close to saturation. One important principle in the implementation of differential amplifiers is the Common-Mode-Rejection ratio (CMRR). The CMRR quantifies the performance of a differential amplifier. Two configurations of a differential amplifier, both having high CMRR, are sketched below (figure 2 and figure 3).

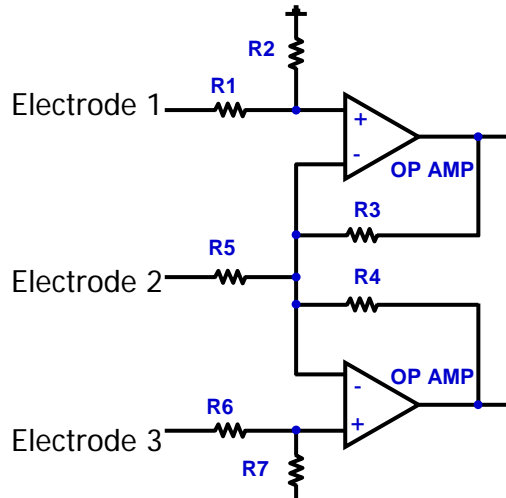

Figure 2: Text book example of a differential amplifier. Differences in voltages between electrodes (reference with electrode 2) are amplified. Attenuation would occur due to resistors placement.

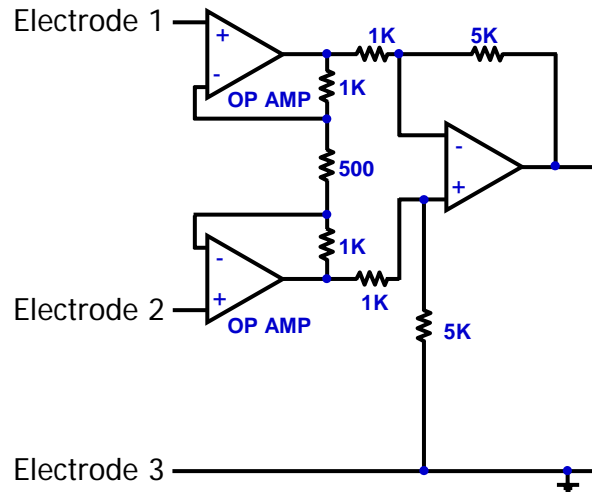

Figure 3: Instrumentation differential amplifiers commonly found in electrocardiogram. No resistor between electrodes and first operational amplifier, therefore no attenuation.

The main difference between the two circuit layouts reside in the placement of the resistors. The differential amplifier depicted by figure 1 has resistors between the electrodes and the first operational amplifiers. This placement of resistors would cause attenuation of the measure voltages prior to amplification, which is an undesired effect.

The circuit layout depicted by figure 2 better suited our design specifications. There is no resistor before the first operational amplifiers, therefore no attenuation of signals. Figure 2 circuit layout is also commonly used in the amplification of electrocardiogram (ECG), which measures the biological stimulation of the heart by action potentials. ECG have many properties similar to an EEG, therefore we adopted the circuit with modifications.

### Filtering

This section of the circuit allows us to pick out frequencies of input signals that are of importance to meditation; we used band-pass filters built from the



combination of high-pass and low-pass filters. Two circuit layouts were considered for the design: first-order filter (figure 4) and second-order filter (figure 6). Beside difference in complexity, the two filters also differ in their fall-off values. Fall-off values are measures of the rate of voltage decrease outside the band of allowed frequencies; the higher the fall-off value, the more ideal the circuit filters. Since our device will be used in a non-clinical setting, a stringent fall-off value is not absolutely necessary; however, relatively high fall-off value is required to distinguish between the alpha (8-13 Hz) and theta (4-8 Hz) signals, which has minimal marginal frequencies between the two waves. The two filter systems, first-order and second-order, were constructed and their response to various frequencies were tested using a waveform generator and an oscilloscope. The output of the waveform generator ( $V_{p-p} = 100\text{mV}$ ,  $f = 1\text{Hz}\sim 80\text{Hz}$ ) was fed into the input of the filters; the output of the filters was monitored with the oscilloscope, and the voltage ( $V_{p-p}$ ) was recorded for individual frequencies. The data obtained for the two filters are shown graphically below.

*First-order filter:*

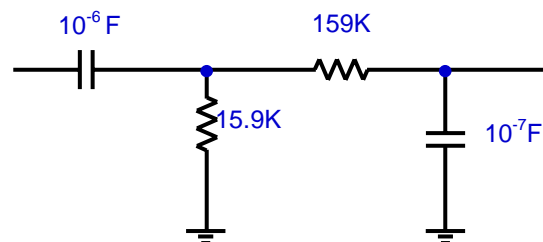

**Figure 4: First-order filter circuit layout.**

The first-order filter is composed of a high-pass filter in series with a low pass filter. The response of the first-order filter is depicted in figure 5. The pass-band of the alpha filter ranges from 2 Hz to 14 Hz; the pass-band of the theta filter ranges from 4 Hz to 26 Hz. The pass-band of the two filters overlapped in the region of 4Hz to 14Hz.

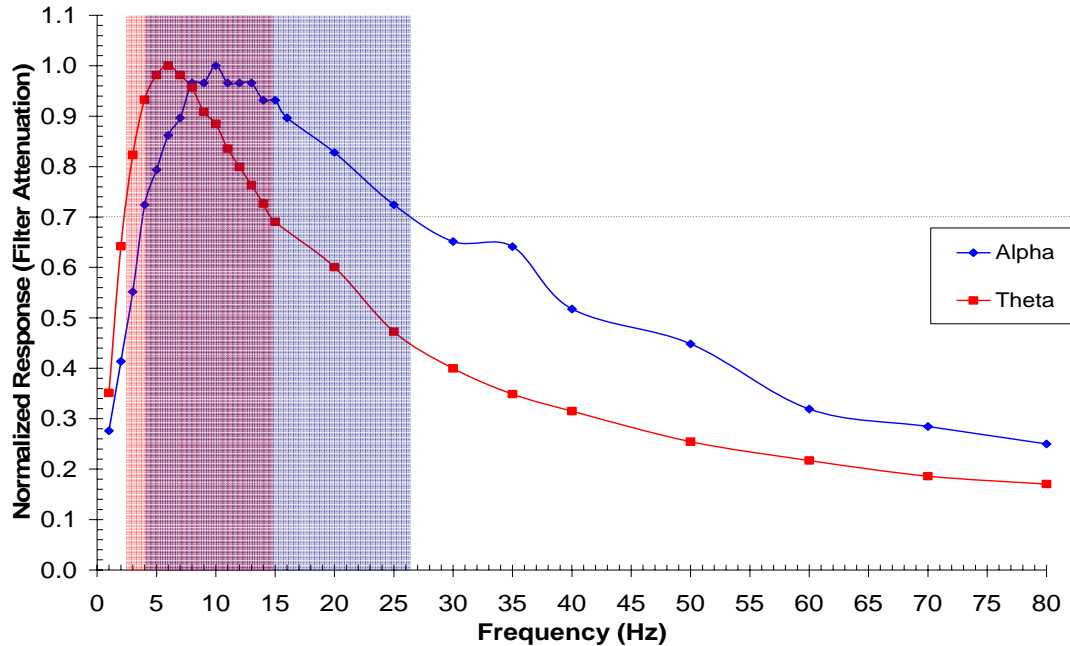

*Figure 5: Normalized frequency response for first order alpha and theta filters.* The responses of the filters were normalized against the highest  $V_{p-p}$  observed with the various frequencies (1 ~ 80Hz) for individual filter (alpha and theta).

### Second Order Filters:

Second order filters are able to more accurately filter out more unwanted frequencies than primary filters. Due to second order properties, the bandwidth can be controlled more with manipulation of resistor values. The basic design of the active filter included 3 resistors, 2 capacitors and an op-amp which are diagrammed in figure 6.

Equations that describe second order filters like the one in figure 6 were taken from Sendra and Smith, 1991. By manipulating these derivations, an equation describing each of the three resistors can be found by setting the capacitor value, band width value, center frequency, and gain of the filter constant. The equations are described in the appendix.

To set the band width value, which is directly related to Q or quality factor (equation can be found in appendix), we needed to find the optimal range of frequencies to pass. Due to the fact that our theta and alpha center frequencies were very close to one

another (6Hz and 10Hz, respectively), a Q value of 3 was chosen. The corresponding range of frequencies that a second order filter with a Q value of 3 would pass is 2 Hz on either side of the center frequency. So, the theta filter should theoretically pass from 4Hz to 8Hz and the alpha filter should pass between 8Hz and 12Hz, leaving no overlap of frequency between the two. Another interesting feature of the second order filter is the limitation on the amount of gain, or  $A(v)$  that can be had in the filter. With a chosen value of 3 as the quality factor, the maximal gain would be 18 times dictated by the term  $(2Q^2 - A(v))$  because resistor values can not be negative. To leave a reasonable margin of error as the components were not perfect, a gain of 10 was deemed sufficient to demand from the filters.

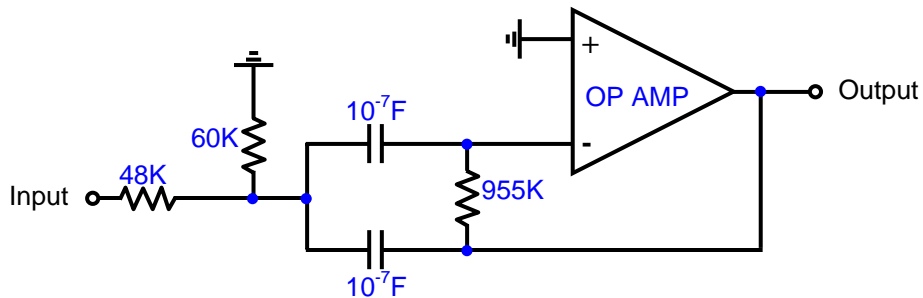

Figure 6: Second order filter layout.

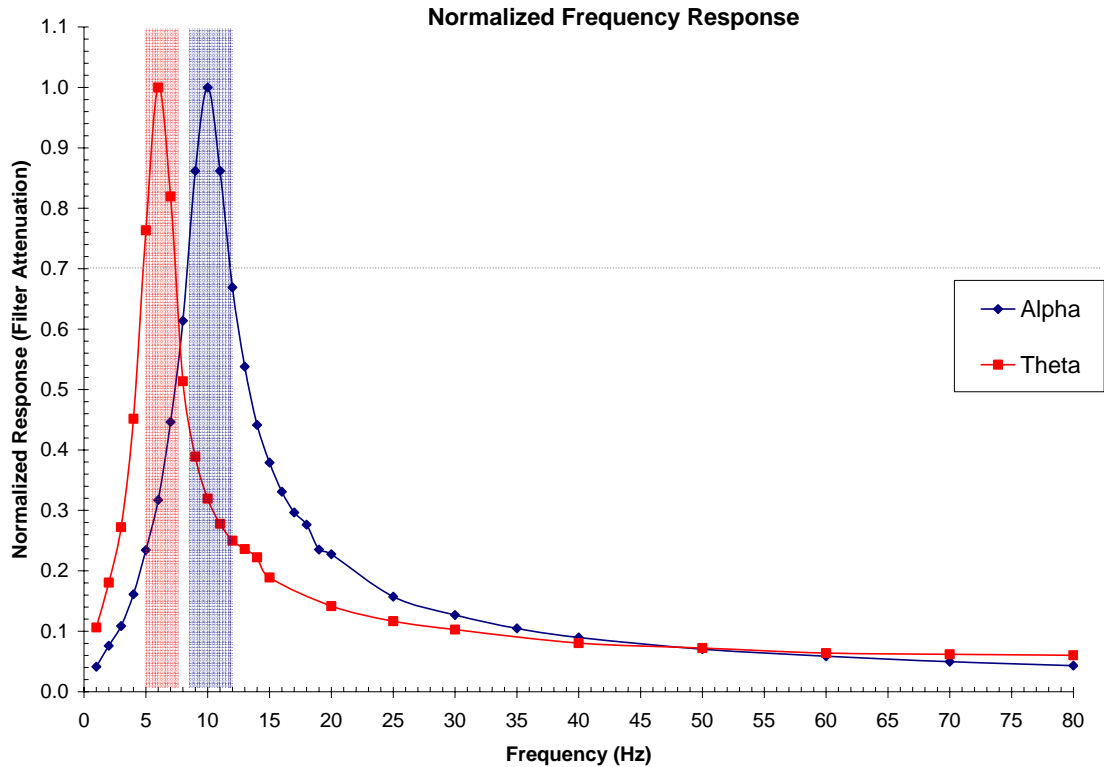
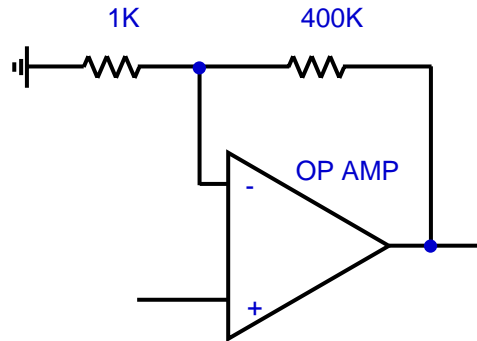

Figure 7: **Frequency response of second order alpha and theta filters.** The shaded regions are representative of the regions that the filter passes .707 or  $1/\sqrt{2}$  of the original signal. Most circuit experts agree this value is a good cut off point and anything above is considered passed.

## Main amplification

In order to amplify the voltages measured by the electrodes, which are on the order of  $100\mu\text{V}$ , an overall gain of  $10^5$  required for an output of 10V, an output decided upon by the Fall 2003 group that worked on the output stage of this project. The preliminary stage provides a gain of 25; the secondary-filters provide a gain of 10; the main amplification stage provides the remaining gain of 400. We achieved the theoretical gain of 400 in our circuit by using a non-inverting amplifier (figure 8). This operation amplifier setup is easy to implement into our circuit, and the gain of the non-inverting amplifier can be easily adjusted by the ratio the resistors. The 400 times amplification was tested in conjunction with the secondary amplifiers, which have a gain

of ten, for a total amplification of 4000 times. When 100mV was input into the circuit, the output was saturation, indicating the final stage was amplifying 400 times.



*Figure 8: Non-inverting amplifier.* The gain of the circuit can be adjust by the ratio of the resistors. Currently, the gain of the operation amplifier is  $4 \cdot 10^5 \Omega / 10^3 \Omega = 400$ .

## Conclusions

Due to the tightly controlled frequency response obtained by the second order filter, it was chosen over the first order to be implemented into the design. First order filtering of the signal would have allowed too large of a band width as testing showed a gain of .707 from frequencies of 4 Hz to 26 Hz in the alpha filter (figure 5). Since the theta filter has a central frequency of 6 Hz and alpha has 10Hz, differentiating between the two signals would be impossible. The overlap would cause an output in both the alpha and theta branches of the circuit for frequencies between 4Hz and 25Hz and this would render the device useless.

As far as amplification is concerned, all of the different stages are achieving the gain required by each of them. The first stage is amplifying 25 times, the second stage (secondary filters) is amplifying 10 times, and the final stage is amplifying 400 times. Put all of these stages together and the overall amplification is 100,000; exactly what is

required by the design specifications. However, we were unable to test the entire circuit all at once. This was due to faulty equipment. In order to test the  $100\mu\text{V}$  input, which is what the circuit is designed to test, we needed to input  $100\mu\text{V}$  into the circuit. This proved to be a very difficult task. A voltage divider was constructed using a  $680\text{k}\Omega$  and  $680\Omega$  resistors for an input of  $100\mu\text{V}$ , but the oscilloscope consistently read anywhere from  $50\text{-}312\text{mV}$  input at all times; even when the leads were not hooked to anything. Thus, it was impossible to determine what size input was entering the circuit. It appeared that an input larger than  $100\mu\text{V}$  was entering the circuit, as every time we used the voltage divider to input the  $100\mu\text{V}$ , we saw saturation of the amplifiers. This would indicate an input much larger than  $100\mu\text{V}$ , because if the input were  $100\mu\text{V}$ , we would see a gain of 100,000 and an output of 10V. More precise equipment would be required for testing the overall gain of the circuit. Another possible method of testing would be the use of a different source. It is possible that the oscilloscope may be actually recording the correct input voltages and it is the source that is varying in voltage. The use of another source, such as EEG signal output from last semester's detection prototype would be an ideal alternate source.

As far as future work, the first step would be to conclude testing of the overall gain of the circuit. Next, the detection prototype from last semester should be incorporated into the amplification/filtering circuit and the apparatus should be tested to determine whether or not it is capable of detecting and then filtering and amplifying the signal as measured by an oscilloscope. Once the circuit from this semester and the detection prototype have been integrated into one design, the next step would be taking the amplified/filtered EEG signals and converting them into some sort of biofeedback

signal in the form of light or a sound. The first step in this process would be taking the output AC signal from the circuit and passing it through a rectifier, which would cut off any negative portions of the output and save all positive portions. Next, the signal would be passed through a signal averager, which would average the positive portion of the output. The amplitudes of the averages of the output would range in size and would be dependant on the input frequency. The largest amplitude average would be at 6Hz and 10Hz, the center frequencies of our filters.

## References

1. Feala, J., et al. (UW-Madison EPICS, Fall 2000). Biofeedback/stress management. <http://homepages.cae.wisc.edu/~meditate/REPORTS03>.
2. Feala, J. and Kane, S. (UW-Madison EPICS, Fall 1999). *Biofeedback from EEG frequency bands*. <http://homepages.cae.wisc.edu/~meditate/REPORTS03>.
3. Gaudet T. Integrative medicine: the evolution of a new approach to medicine and to medical education. *Integrative Medicine* 1998;**1**:67-73.
4. Anderson, A., III., Wegener, C., Thome, R., Shikha, & Lorenz, M. (UW-Madison BME Design, Fall 2005). *Portable Electroencephalogram Biofeedback Device*. [http://homepages.cae.wisc.edu/~bme200/eeg\\_biofeedback\\_fall05](http://homepages.cae.wisc.edu/~bme200/eeg_biofeedback_fall05).
5. MettingVanRijn, A.C., A. Peper, and C.A. Grimbergen. (1994). Amplifiers for bioelectric events: a design with a minimal number of parts. *Medical & Biological Engineering & Computing*, 32: 305-310.
6. Jain, V.K., and Agarwal, A. (1976). A Spectrum Analyzer for EEG Signals. *Journal of Instrumentation Electronics and Telecommunications Engineers*, 22: 797-802.
7. Birkeneder, E., Kinney, K., Valley, C., and Miller, E. (BME Design-Fall 2003). *Biofeedback and stress management*. <http://homepages.cae.wisc.edu/~bme402/biofeedback>.

## Appendix

Equations that can be used to find resistor values of the second order filter.

$$R1 = Q / (2\pi * f(c) * A(v) * C)$$

$$R2 = Q / (2\pi * f(c) * C * (2Q^2 - A(v)))$$

$$R3 = 2Q / (2\pi * f(c) * C)$$

$f(c)$  = center frequency

$Q^*$  is quality factor

$C$  is the capacitor values

$R1$ ,  $R2$  and  $R3$  are the values of the resistors

$A(v)$  is the gain, also described as  $R3/2 * R2$

$*Q$  is described as Center Frequency / Band Width

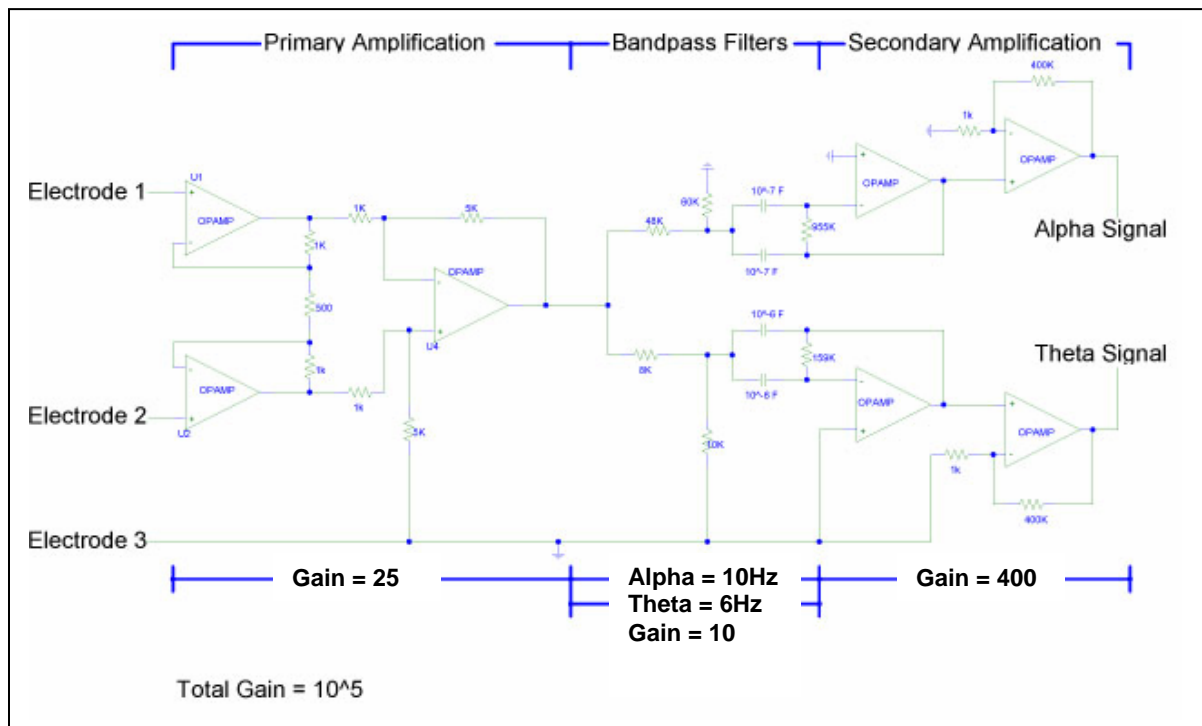

Figure 9: The entire circuit with all stages combined.



## Product Design Specifications

**Function:** The portable EEG (brain wave monitor) will take an incoming signal from a series of electrodes, amplify the signal to measurable and interpretable levels, filter out specific frequencies and present the occurrence of those distinctive brain waves in a manner applicable for biofeedback.

### Client Requirements:

- A device that minimizes complicated user input (simplistic like an iPod)
- Final cost of \$100-200
- A type of biofeedback output that is not distracting to the user during meditation

### Design Requirements:

#### *Physical and Operational Characteristics*

- Performance: Device should be able to be used for a minimum of two hours on a single battery charge, with the possibility of daily use.
- Aesthetics, Appearance, and Finish: Device should be minimally complicated visually, with an interface similar to that of portable music players (such as an iPod). The shape should be rectangular, and colors should be pleasing to the eye without being distracting.
- Safety: Device should be free from danger of shock, and be appropriately labeled to warn of this danger as well as damaging interaction with electrical components.
- Size & Weight: Device should be portable and easy to transport.
- Accuracy and Reliability: Device should produce feedback accurate enough for qualitative analysis, not necessarily clinical applications.
- Operating Environment: Device should be able to be operated by one person, in reasonable indoor/outdoor conditions (not extremes such as in rain/bathtub), and be able to withstand the typical wear associated with accidents and everyday use.
- Materials: Should incorporate a maximum number of reusable parts.
- Life in Service: Device should last a minimum of 5 years.

#### *Production Characteristics*

- Quantity: The portable EEG will be relatively mass-produced for consumer delivery.

- Target Product Cost: \$100 - 200, compared to commercial versions ranging from \$1,000 – 5,000

Other Characteristics

- Standards and Specifications: Meets national standards for electronic devices, as well as FDA requirements (Level 1 or 2?).

- Customer: Device should be conducive to a meditative environment (comfortable, a user-friendly, simple interface)

- Patient-related concerns: Preparation of the electrodes may be extensive, requiring daily cleaning, and eventual replacement.

- Competition: Should be able to produce comparable signal quality and feedback for a lower price, smaller packaging, and no necessary training.

*N.B. A patent search found a similar device using rapid LEDs as the feedback mechanism.*