

Medflight Manual Hands-Free Ventilator Project

Peter Ma- Group Leader

Matthew Valaskey- BWIG

Richard J. Long- Communications

Jimmy Fong- BSAC

BME 201

March 3, 2006

Client: Michael K. Abernethy, MD, FACEP

Advisor: Dr. Paul Thompson, University of Wisconsin

Abstract: The existing manual ventilator bag (commonly referred to as “AMBU bag”) is researched and analyzed. Three new designs are presented that allow for the manual ventilator to operate as a hands-free operation. The goal of these designs is to create a product that meets the standards of the current AMBU bag while allowing the doctor another means to manually ventilate the patient while maintaining free use of his or her hands. The product must adequately replicate the respiratory function of traditional ventilators in order to provide the patient with sufficient oxygen and prevent overexposure to harmful toxins that are part of the respiratory process.

Overview:

- I. Problem Statement**
- II. Background Information**
- III. Materials and Methods**
- IV. Management Planning**
- V. Ethical Considerations**
- VI. Alternative Designs**
 - i. Belt Attachment**
 - ii. Hinge Design**
 - iii. Foot Bellow Pump**
- VII. Discussion & Results**
- VIII. Future Work**
- IX. References**

Note: Updated Product Design Specifications are attached to end of report.

I. Problem Statement:

The goal of the project is to create a ventilator for the UW Medflight team that replaces the traditional method of providing hand-powered manual ventilation with a hands-free method that gives the client greater ability to assist victims. The incentive of the hands-free method is that it allows the doctor to devote more attention to the patient while still performing the ventilation process. A common complaint among those who use hand-operated ventilators is that it is often too risky to try to operate the ventilator while performing other tasks. Medflight helicopter conditions are characterized as being cramped, due to the large amount of medical equipment on board, leading to the doctor most always working alone in the field. The project is intended to allow for the doctor on board to perform other tasks along with the ventilation process, catalyzing the process of individually providing life-saving treatment.

II. Background Information:

The product's function is extremely important for members of the Medflight team. Medflight is composed of physicians, nurses, pilots, and dispatchers that are specially trained in transporting patients in emergency situations. This flight service has provided emergency care and transport for victims of crashes and disasters for more than twenty years. The University of Wisconsin's Medflight has three rotating helicopters available at all times. This Medflight team works in a 225 mile radius around Madison. The helicopters can be in the air within minutes of receiving word of an accident. Many pieces of emergency equipment are carried in flight such as: ventilators, blood pressure monitor, heart monitors, IV equipment, defibrillators, pacemaker equipment, emergency

medicine, and medication. During the transportation of a patient, the physician's task is to maintain life and stabilize the person until they arrive at a location where better care or treatment can be provided.

During the research process we have consulted with our client, Dr. Michael Abernethy, when analyzing the feasibility of the several of the proposals we will discuss later in the text. While researching the project several websites highlighted the importance of the Positive End Expiratory Pressure Valve (PEEP Valve) as being critical to providing safe ventilation and avoiding harmful toxins that are part of the respiratory process. While the PEEP Valve (which is commonly referred to in the text) is in important, its main function is not to protect the patient from toxic gases that are a product of respiration, but rather to control the rate of air flow in the respirator to keep the patient's lungs from reaching zero pressure during exhalation. During normal respiration, the lungs do reach a moment of zero pressure during exhalation. However, in times of trauma, always maintaining some pressure in the lungs is beneficial. This pressure eases the burden that is placed on the patient who is having trouble breathing, providing them with sort of a reservoir to continue the breathing process with.

Having had some members with prior experience working with Dr. Abernethy and Medflight, the factors were clear and concise from Day 1. The important factors that are being considered when making decisions pertaining to these proposals mainly have to do with the pressure the proposed ventilator delivers or is expected to deliver to the patient, its ease of operation, and the logistics of operating the device in the cramped conditions that are part of basic Medflight operation.

It is hard to understand the amazing efficiency of the hand-operated AMBU bag. The AMBU bag does not require strenuous pumping because it efficiently delivers sufficient volumes (1300 mL) within safe pressure ranges. For this reason, Dr. Abernethy has clearly stated that it is imperative to maintain standards within acceptable ranges of the AMBU design. Failure to do this would create more problems than not having the ability to work with your hands and compromise patient care. Dr. Abernethy often deals with patients that are in tremendous need of medical attention, along with respiratory assistance. His advice has lead us to make sure that product efficiency and performance goes hand-in-hand with the ergonomics of each design. After all, a sleek design that compromises efficiency does not make Medflight operation any easier for the client. Having done extensive research on manual respiration and PEEP Valve function, we were able to break down the process try to build a design that fit the setting along with operating efficiently with acceptable performance.

In order to make hands-free operable AMBU bag, it became clear that the compressible “bubble” portion of the AMBU bag, traditionally compressed by the hand, needed to be replaced or relocated for hands-free use. One possible replacement is bellow pump, a foot pedal type pump often used for inflating air mattresses or similar items. Several manufacturers produce bellow pumps. We found the Sevylor to be one of the most common manufacturers, with a small variety of pumps to choose from. The ergonomics of the bellow pump were immediately pleasing. These pumps are designed to be manually pumped by foot for a short duration, and given their shape, could easily have a pumping force generated by some part of the body other than the foot. One drawback, however, of the bellow pump, is the way it moves air. The bellow pump is

designed to move as much air as possible for a reasonable amount of effort. As a result, even smaller versions of these pumps move volumes of air as large as 3000 mL with each pump, nearly three times the accepted value of 1300 mL for an AMBU bag. Another issue is the amount of pressure that a bellow pump could possibly generate. Due to its design, the pressure in the bellow pump is dependent upon the force exerted on it, much like the AMBU bag. Being operated by foot, the bellow pump may lack the tactile feedback of an AMBU bag, making it more difficult for the user to control rate and volume of air moved as opposed to the AMBU bag. In order for a bellow pump to be safely incorporated into a design, it must be capable of delivering a sufficient volume of air at a safe pressure, without potential of exceeding accepted values.

Another important consideration in our designs is the concept of “dead space”. During the process of respiration, the patient inhales and exhales air through the same tube. Ideally, when the patient exhales, all of the gases would be released, not to be inhaled again. However, it is inevitable that exhaled air will stay in the tube in the length of tubing that runs from the patient to the respective location where the exhaled gases are exhausted. This air is then inhaled again with the next breath. “Dead space” refers to the volume of this length of tube that contains exhaled air that will be reinhaled. It is very important that this volume is not of significant size when compared to the average breath volume of 1300 mL to ensure that the patient is not overexposed to the toxic products exhaled during respiration.

III. Materials and Methods

Our client supplied us with ample tubing and ventilation equipment which allowed us sufficient resources to plan and evaluate our design proposals. We were able to spend enough time with the client to gain a firm grasp of what direction we wanted to take with the project. The designs were created in an effort to gain maximum efficiency out of the materials that were provided by the client. Physical implementation has yet to take place but will begin shortly after we finish breaking down the materials in our inventory. Once prototypes are constructed, our client will be able to provide equipment to test performance specifications such as volume and pressure. The existing inventory consists of tubing material along with AMBU bags consisting of PEEP valves and ventilation equipment.

IV. Management Planning

The group firmly believes that we will be able to accomplish the entire fabrication process without the use of outside assistance. We estimate that it will take approximately 20 hours to build an acceptable working prototype using the materials given to us. Necessary materials such as the PEEP Valve and ventilation tubing was given to us, saving us anywhere between 100 to 200 dollars. The Foot Bellow equipment can be purchased from various retailers, for prices ranging from 10 to 30 dollars. Accessory materials will not provide with any financial burden and will mainly consist of plastic parts that will be used to attach parts together and provide aesthetic detail. The final prototype will not cost the group more than 60 dollars because of the material given to us. However, if the materials were not provide the unit production price would be around

250 dollars because ventilation material would not be provided. The group believes the project will not require a sufficient amount of strategy because our designs go into detail covering the specifics of the project.

V. Ethical Considerations

To ensure the safety of the patient, the hands-free respirator must function within pressure, volume and air quality limits of a traditional respirator. Breathing pressure in the lung is measured in centimeters of water above normal atmospheric pressure. Typically, normal breathing inflates the lungs to 36 cm H₂O above atmospheric pressure, causing the lung to be 70% inflated. This is equivalent to 26.47 mm Hg above the normal atmospheric pressure of 760 mm Hg. The oxygen concentration should be kept as high as possible. With an oxygen tank attached, the concentration of oxygen should be kept close to 100% with an efficient exhaust and possibly the addition of an O₂ reservoir.

VI. Alternative Designs

i. Belt Attachment

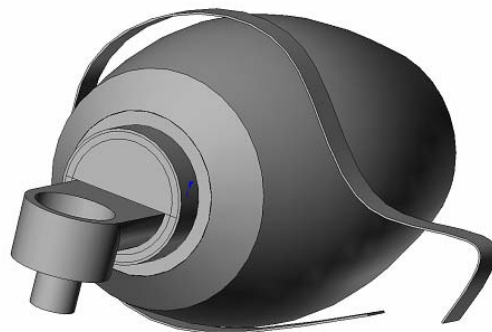

Figure 1: Front view of the belt attachment design

The belt attachment design involves a customized belt that attaches around the AMBU bag. This belt is used to mount the “bubble” portion of the ventilator to the leg of the operator securely and can be easily detached. After placing it at the most comfortable location, the valve end of the AMBU bag would be placed beside the knee. This prevents the respirator from separating from the extension tubing. By moving the knees together, the operator can compress the bag and force air from the bag into the patient’s lungs through extended tubing. The end of the extended tubing, distal from the operator, is connected to a PEEP exhaust valve which prevents the accumulated carbon dioxide from reaching the patient and maintains some beneficial pressure in the lungs. The belt should be adjustable from 15 inches to 20 inches so that it can fit the majority of leg sizes. The operator must also be able to attach and detach the AMBU quickly and easily.



Figure 2: Back view of the belt attachment design

A major advantage of the belt design is its ability to be set up in a small amount of time. This is because the only detachable components are the belt and the extension tubing. This feature also allows the respirator to be stored easily and reduces the cost of

production. The oxygen flow supplied by this design is already within human respiratory regulations because the original AMBU bag is used.

The disadvantages of this design, however, limit its potential of being widely used. The motion that this design requires is non-intuitive and provides much less tactile feedback when compared to the hand model, possibly making it difficult for the operator to control the air flow. This may cause the user to be preoccupied with operating the respirator and prevent him or her from performing other critical tasks.

ii. Hinge Design

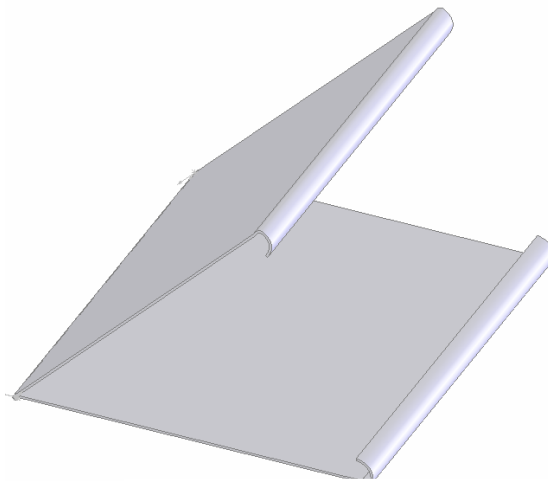

Figure 3: A mechanical hinge

The hinge design compresses an AMBU bag with the movement of a customized mechanical hinge. The hinge would be controlled by a hydraulic pedal actuated by highly compressed fluid through tubing. Once activated, the upper part of the hinge will lower and thereby, compressing the AMBU bag. As expected, the top of the hinge will rise once the pedal is released causing the AMBU bag to re-inflate. This hinge rests on top of the patient and only requires a short extension tube.

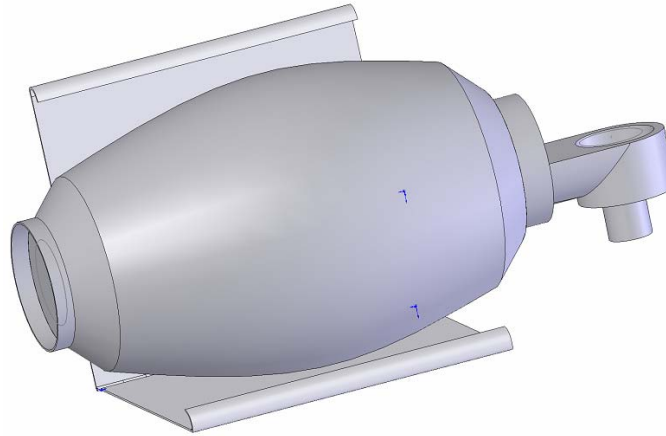

Figure 4: Hinge combined with respirator

This system allows the operator to accurately control the air flow to the patient. The motion of activating the pedal is intuitive and allows the user to use his or her hands for other important duties.

The construction process for this design, though, will be relatively complicated as there are basically three components: a hinge, a pedal and a hydraulic system. All these contribute to the manufacturing cost of the prototype. The placement of the device on top of the patient is not as stable as a system placed on a fixed surface. Further development and advanced design may be able to make this concept a viable option in the future.

iii. Foot Bellows Pump Design

The third design alternative involves a separate foot pump that the client can place on the ground and operate without any compromise of his hands. This design stresses the intuitive foot pedal motion that drivers employ when controlling the throttle of the car

and allows the doctor to control the flow of oxygen with the amount of foot pressure on the pump. This design utilizes four main elements to replace the function of traditional respirators: a bellows foot pump, an extension for the ventilation circuit, an exhaust valve and an oxygen reservoir.

The primary component of the pump design is the actual bellows pump itself. The average size for an AMBU bag respirator on the market is 1300 mL, therefore, the bellows pump should have a comparable volume in order to deliver the same volume of oxygen. As a force is applied forward from the operator's foot, the pump chamber collapses and forces air from the pump into the reservoir and the ventilation circuit. The pump would also possess a valve connector for an oxygen tank tube that could be attached if needed. The underside of the bellows pump would be coated with a non-slip to prevent the pump from slipping during operation.

The function of the reservoir in a traditional respirator bag is to provide a small supply of oxygen to the pouch when the rate of pumping is too high to allow for the pouch to be filled quickly enough by the oxygen tank. The reservoir will be incorporated in the pump design as a plastic bag attached directly to the bellows pump. This will allow the reservoir to be filled with air or oxygen first before the pump. If oxygen is not filling the pump fast enough, the oxygen will be drawn from the reservoir instead.

An issue that arises in the design of a respirator with a distal oxygen supply is the amount of dead space in the ventilation circuit from the respirator to the patient. This dead space causes a reduction in oxygen pressure that reaches the patient and allows carbon dioxide to contaminate the air supply. In traditional respirator the carbon dioxide from exhalation exits the ventilation circuit through an exhaust valve connected to the

pouch and the mask. Since the pump design has the mask separated from the bellows pump by approximately 2 m, the exhaust valve will need to be attached to the patient’s mask at the end of the circuit. A standard ventilation exhaust valve could be used, but this design will implement a positive end expiratory pressure, or PEEP, valve.

A PEEP valve is a specific type of exhaust valve that allows a specific pressure to be maintained in the system and the lung after exhalation. In this case, the amount of pressure is simply adjusted by turning a threaded knob on the valve. Like any other exhaust valve, the opening will only allow for airflow in one direction. A diaphragm lets carbon dioxide and other exhaled gases out of the system, but does not allow ambient gases to enter the system.

VII. Discussion & Results

<i>Factor</i>	<i>Weight</i>	<i>Belt Attachment</i>	<i>Hinge</i>	<i>Foot Bellow</i>
Design Feasibility	3	5	3	5
Expected Performance Output	5	3	3	4
Comprehensive Design	3	4	3	5
Reliability	5	4	3	4
Ease of Use in Medflight Conditions	4	3	4	5
Cost	2	5	3	4
Total		87	70	98

Figure 5: Design Matrix

When analyzing the three designs, we focused on six main factors, design feasibility, expected performance output, comprehensive design, reliability, ease of use in Medflight conditions, and finally cost. When considering these factors, it was decided to give more weight to those concerning performance and function due to the life-sustaining function the ventilator provides, as seen in Figure 5.

We feel that all three of our designs are capable of solving Dr. Abernethy's problem and allowing hands-free ventilation, but when all things are considered, the foot bellow design is the most logical choice. One of the main appeals of the foot bellow design is the foot pumping motion required for its operation. This motion is very intuitive, much like the motion of pressing a gas pedal in an automobile. Since this motion is more familiar than those that would be required to operate the other designs, the learning curve would be shorter for the operator in respect to the other designs. This device would also fit well in the small confines of the Medflight helicopter, where the bulk of the device would rest on the floor, out of the way of the flight physician and the other equipment.

The main problem the group has anticipated with the foot bellow design is the possible difficulty in controlling air flow. It is likely going to be necessary to modify the bellow pump in order to limit its output, since most bellow pumps are designed to deliver a much greater volume than the acceptable 1300 mL. As a group, we are confident we will be able to overcome this problem once a bellow pump is obtained and we are able to gain more insight into its workings. If the bellow pump proves not to be a suitable replacement for the compressible portion of a traditional AMBU bag, we are prepared to

adapt the bellow design to the traditional bag. In doing this, we would create a mechanical hinged foot pedal very similar to Figure 3. This would enclose a traditional AMBU bag. By varying the force necessary to move the hinge, its range of motion, and the shape of the inner surfaces that contact the bag, it would be possible to control the output of the device while providing the same foot pedal motion for the operator.

VIII. Future Work

In order to proceed with our foot bellow pump design we would need to order a foot bellow pump, obtain tubing for the ventilation circuit and modify the traditional respirator bags that we received from our client. We plan testing the prototype as we build so that modifications can be made if needed. The UW Hospital provides all the equipment necessary to test air flow rate, pressure and percent O₂ saturation. Weekly emails with semi-regular meetings will be maintained with the client in order to facilitate communication and allow for the client's input in the project. Our goal is to be able to provide our client with a working prototype that allows for easy hands-free use, while meeting the necessary performance specifications.

IX. References

- Campbell, N. Reece J. Biology, 2005. Pearson Benjamin Cummings Publishing. 7th Edition.
- “Ambu Inc.” 1 Feb. 2006 <<http://ambu.com>>
- “Sevylor Inc.” <<http://sevylor.com>>
- Dr. Michael Abernethy. UW- Medflight Flight Physician
- “Initial Response Online Store: Ventilator circuit” <<http://www.initialresponse.com> >
- “Lung Physiology and Respiration” 27 Jan. 2006
<<http://people.eku.edu/ritchisong/301notes6.htm>>
- Advisor Dr. Paul Thompson
- “Instrumentation Industries Inc” 1 Feb. 2006 < www.iirespiratory.com>
- “Manual Ventilation” 27 Jan. 2006 <www.wikipedia.com>

Product Design Specifications

Hands-free Ventilator Project

March 3, 2006

Team Members:

Peter Ma *Leader*

Richard Long *Communications*

Jimmy Fong *BSAC*

Matt Valaskey *BWIG*

Function:

The product function is to modify the disposable manual ventilator (AMBU bag) to allow hands-free operation. This could be operated by foot or legs with the user in a sitting position.

Client Requirements:

The project will allow for hands-free operation of the manual ventilator (AMBU bag), using the client's legs or feet. Traditionally, AMBU bags operate as an inflatable bag by hand. To allow for the AMBU bag to be operated using legs or feet, an extension piece needs to reach the patient. The extension piece needs to still maintain the current capabilities of the manual ventilator and assist in respiration (adequate exchange of oxygen and carbon dioxide). Failure of the extension piece to adequately replicate the respiratory function of the traditional AMBU bag would result in the patients becoming

overexposed to harmful carbon dioxide and also suffering from oxygen deprivation.

Design Requirements:

1) Physical and Operational Characteristics

- a. *Performance Requirements:* Product needs to still maintain the current capabilities of the AMBU manual ventilator and assist in respiration (adequate exchange of oxygen and carbon dioxide). Product should be able to provide maximum delivery volume of 1300 mL.
- b. *Safety:* Product must adequately replicate the respiratory function of the traditional AMBU bag to prevent patients from becoming overexposed to harmful carbon dioxide and also suffering from oxygen deprivation.
- c. *Accuracy and Reliability:* Product must sufficiently allow for oxygen carbon dioxide transmission. Product must provide adequate oxygen to the patient while eliminating carbon dioxide buildup in the tubing.
- d. *Life in Service:* Product should be able to tolerate traditional helicopter conditions. Damage and wear can be repaired by tubing and plastic repair. Product is repairable. No disposable model is being made.
- e. *Shelf Life:* Shelf life should last the same length of the traditional AMBU bag which traditionally last 1-2 years without leaks.
- f. *Operating Environment:* Since Medflight operation takes place year round, the device will be able to endure a variety of weather conditions including moisture, high and low temperatures. Traditional AMBU Bag is operable in temperatures ranging from 0°F to 122°F.

g. *Ergonomics*: Product is designed to comfortably fit at client's feet or on his leg and stretch to the patient. Product will feature traditional bag base and tubular extension.

h. *Size*: Extension piece will stretch from air source to patient. Extension piece will be in tubular shape to allow for oxygen-carbon dioxide transmission. Traditional AMBU bag reservoir volume is 1500 mL with a maximum delivery volume of 1300 mL.

i. *Weight*: Final weight will be determined but should not restrict operation ability or cause increased discomfort. Traditional AMBU bag weight is .92 lbs (without oxygen), approx.

j. *Materials*: Ventilator extension will be crafted using tubing material and plastic that is similar to that used in AMBU bag prototype which consists of crafted silicone rubber.

k. *Aesthetics, Appearance, and Finish*: Product should be free from excess appendages that take up excess space.

2) Production Characteristics

a. *Quantity*: 1, with the possibility of further replication.

b. *Target Product Cost*: Estimated Cost: \$10.00 cost of traditional disposable AMBU bag. Target Product Cost most likely to include the cost of disposable AMBU bag, extension materials (crafted with similar materials used in AMBU products), and other bellows instruments used to simulate respiration. Target Product Cost most likely to exceed cost of disposable bag.

3) Miscellaneous

a. *Standards and Specifications:* none.

b. *Customer:* Product needs to minimize “dead-space” that could in extension piece and become contaminated with carbon dioxide. Traditional AMBU bags contain less than 5 mL dead space.

c. *Patient-related concerns:* Product needs to be free from harmful materials (i.e. carbon dioxide) and have all performance capabilities as original AMBU bag.

d. *Competition:* none