

Breast Pedicle Protector

BME 201
University of Wisconsin – Madison
May 9, 2007

Team:

Kuya Takami, *Team Leader*
Nathan Werbeckes, *Communications*
Joseph Yuen, *BSAC*
Laura Bagley, *BWIG*

Client:

Michael Bentz, MD, FAAP, FACS
Dept. of Surgery
UW Medical School

Advisor:

Prof. Naomi Chesler
Department of Biomedical Engineering

Table of Contents

Abstract.....	3
Product Design Specifications	
<i>Physical and Operational Requirements</i>	4
<i>Safety Concerns</i>	4
Background	
<i>Need for breast reduction surgery</i>	5
<i>Breast reduction procedure</i>	6
Design Alternatives	
<i>Design 1: No Moving Parts</i>	8
<i>Design 2: 2D Adjustable, Snap-on pieces</i>	9
<i>Design 3: 2D Adjustable, Spring Mechanism</i>	10
Design Matrix.....	11
Final Design	
<i>Construction – Prototype 1</i>	12
<i>Construction – Prototype 2</i>	13
<i>Material Choice</i>	14
Future Work.....	14
References.....	16
APPENDIX 1: Product Design Specifications.....	17

Abstract

During breast reduction surgery, the surgeon requires an assistant to hold the breast in place while he/she cuts away the excess breast tissue. Working around the assistant while maintaining the breast position and ensuring both breasts are reduced evenly is difficult and time consuming. The goal of this project is to design a device that will hold the breast in place during surgery and protect the breast pedicle, the tissue that supplies blood and nerves to the nipple. The device will surround the breast pedicle with needles that serve as a guide for the surgeon to cut along. The device should adjust to fit each patient. The use of this device will eliminate the need for an assistant and thus increase the surgeon's precision and decrease the time required to complete the procedure.

Product Design Specifications

Physical and Operational Requirements

The device needs to adjust to each patient. The width should adjust between 5 cm and 10 cm. While it would be acceptable for the length to be a fixed 8 cm, it would be desirable to have the length cover a range from 6 cm to 12 cm. The adjusting mechanisms should be accurate within 5-10 mm. The needles protruding from the device should be approximately 10 cm long and be placed no more than 1 cm apart. The needles should be 3-4 mm in diameter to easily penetrate the breast tissue and be made of a material that will not deform due to forces applied during surgery. The tip of the needle should be rounded similar to a knitting needle to avoid excessive tissue damage. Ideally, the device will be made entirely of stainless steel. Finally, the device needs to be operable by one person.

Safety Concerns

The major safety concern is patient comfort and recovery time. The tips of the spikes should be sharp enough to penetrate fat tissue, but not so sharp as to penetrate the muscles lying beneath the breast tissue. The length of the spikes is also a factor in whether or not the device penetrates the muscle. A length of 10 cm should be long enough to hold the breast steady in patients of varying sizes but short enough to avoid piercing the muscle of most patients. Because the ribs lie directly underneath the chest muscles and would prevent the device from penetrating internal organs, it would not harm the patient if the device were to completely penetrate the fat layer and come into contact with the muscle. It would, however, cause more bruising and pain during recovery.

Background

Need For Breast Reduction Surgery

Breast reduction surgery is not generally a cosmetic procedure. Surgery is needed to improve the physical, developmental, social and emotional problems that excessively large breasts cause. These symptoms are usually pressing enough to be covered under a woman's health insurance, and therefore not treated as cosmetic surgery. Abnormally large breasts develop pathologically, often in women entering puberty, coming out of a pregnancy, or going through menopause, which indicates that hormones usually play some role in the disorder.

The physical symptoms associated with overly large breasts vary by age. If the breasts become very large during the start of puberty, patients are diagnosed with virginal

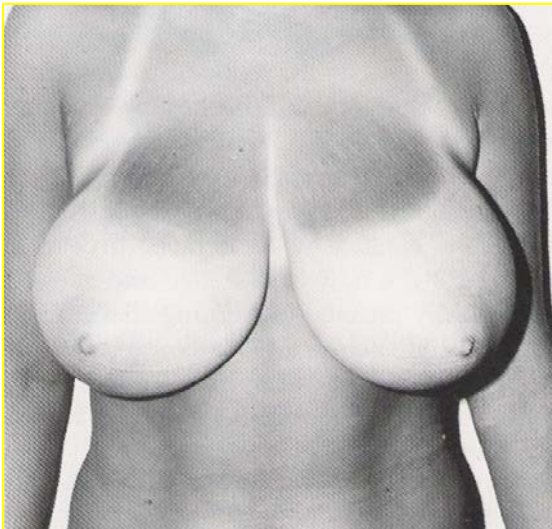

hypertrophy (see figure 1). These young women are between the ages of 11 and 15. Doctors are also concerned about how the girls' posture develops. Women with heavier breasts, no matter what age, may also be afflicted by shoulder grooving, neck and back pain, thoracic curvatures, and upper extremity neurological symptoms due

Fig 1: candidate for breast reduction surgery, virginal hypertrophy (Bostwick, 1983)

to compression of the brachial plexus. Additionally, pendulous breasts lead to issues with moisture and other dermatoses due to the skin-on-skin contact. (Bostwick, 1983)

Not all consequences of large breasts are immediately apparent, but some are more obvious, such as being larger than what is considered attractive, appearing heavier than she actually is, or having trouble finding clothing that fits properly. Larger breasts also impair physical functioning in activities such as running, golf, or tennis.

Lastly, overly full breasts prevent a timely diagnosis of tumors. The overall size reduces the area in which a cancerous tumor would be easily seen or felt. Therefore, large and advanced cancerous masses may grow without medical attention. (Bostwick, 1983)

Breast Reduction Procedure

The most commonly used technique for breast reduction surgery is the inferior-pedicle technique. This procedure is used for breasts that are wide, pendulous, or just large (600 to 2000 g). It is also used for moving the nipple upwards in an otherwise normally sized breast. The technique can reduce the mass by as much as 800 g, and move the nipple-areolar complex vertically as much as 8 cm. (Spear, 2006)

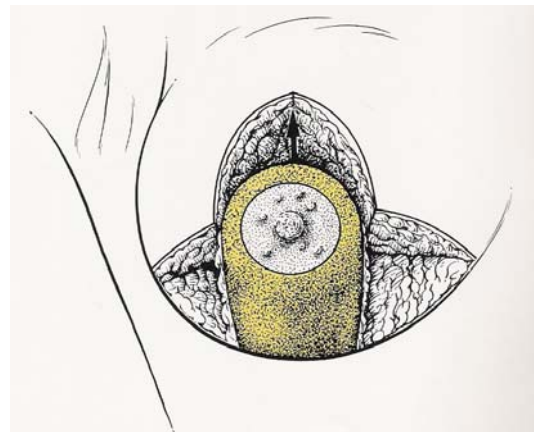

Fig 2: where tissue will be removed (Spear, 2006)

The surgery removes adipose tissue that is directly superior, medially-inferior and laterally-inferior to the nipple-areolar complex (see figure 2). The tissue that is directly inferior is preserved. This section of tissue is known as the central pedicle and must be retained as it brings blood and nerves to the nipple and areola. Harming this region can

lead to loss of feeling, lactation, and in the worst case the nipple dies and sloughs off.

The purpose of the proposed device is to prevent any damage to the central pedicle.

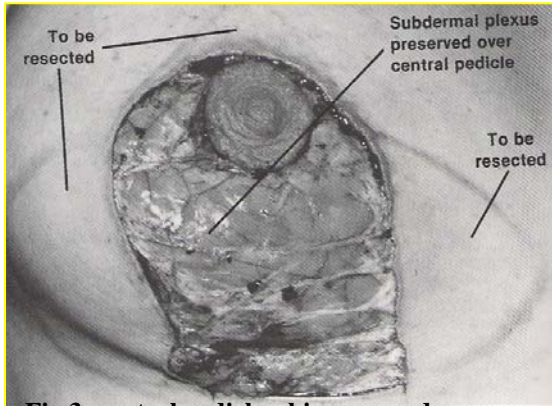

Fig 3: central pedicle, skin removed
(Bostwick,1983)

The surgery begins by removing the skin around and inferior to the areola. In figure 3, the skin has been removed to reveal the central pedicle. At this stage, the device

would be placed onto the pedicle to protect the blood vessels, nerves and mammary glands contained within it. The device also needs to provide a straight edge to cut against when removing the medial and lateral inferior tissue. The current procedure involves a second pair of hands to hold the breast in place while all cuts are being made. There are currently no tools or equipment on the market that surgeons can use to hold the breast and the pedicle in place when removing the excess tissue. Figure 4 shows the removed tissue and from what area of the breast the tissue came.

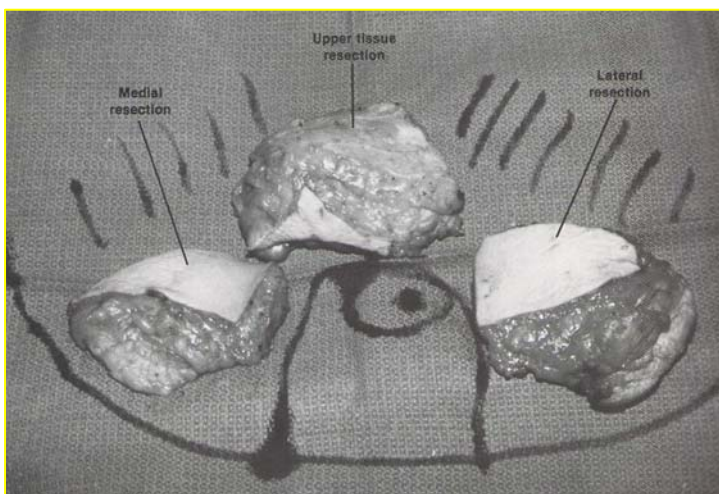

Fig 4: dissected tissue (Bostwick, 1983)

Design Alternatives

Design 1: No Moving Parts

The first design consists of fixed width, length, and height (see figure 5). The

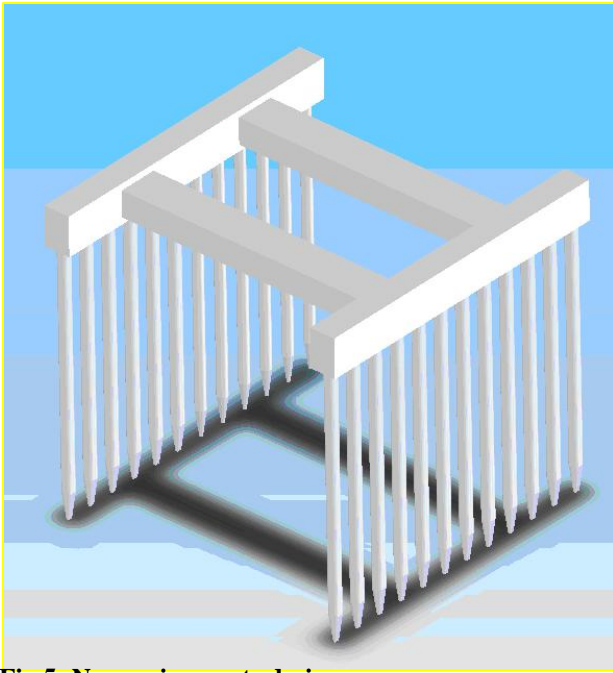

Fig 5: No moving parts design

length and height are 8 cm and 10 cm, respectively. A length of 8 cm will fit most patients, and a height of 10 cm will cover a wide range of breast thicknesses. Width, however, must vary between 5 cm to 10 cm depending on the patient. This problem can be solved by making six devices; the first device will have a width of 5 cm and each subsequent device will increase in width by 1 cm. The two

bridges that connect the two rows of needles can be used as a handle during the surgery. The opening between the bridges gives the surgeon a clear view of the areola during surgery. Since this design is simple and contains no moving parts, it is easy to construct and there is no risk of the device accidentally adjusting during surgery. It is also easy to sterilize because there are few places for debris to get trapped. Having multiple devices, however, requires more storage space and the risk of losing a device is increased. This design also does not allow for adjustment more precise than 1 cm.

Design 2: 2D Adjustable, Snap-on Pieces

The second design adjusts both width - and length –wise (see figure 6). The width adjusts with a sliding track and locks with a simple screw mechanism. It has a range of 5-10 cm. The sliding track is created by having the bridge on one row of

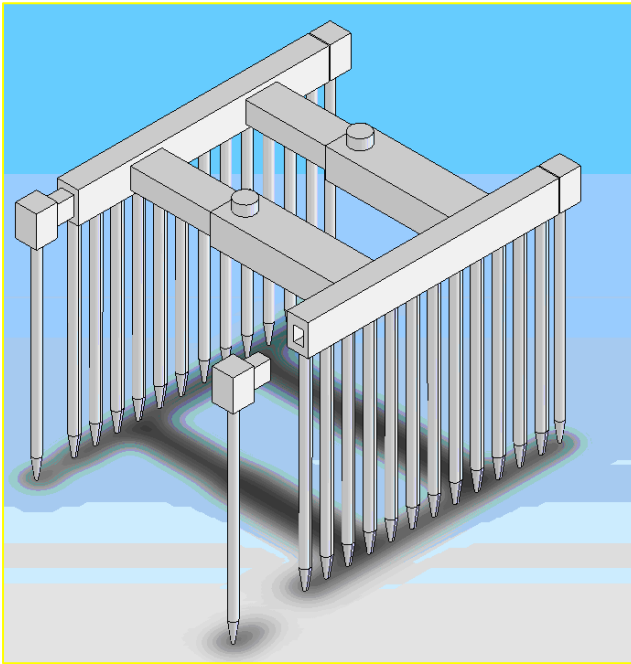

Fig 6: 2D adjustable, snap-on pieces design

needles fit inside the bridge on the other row of needles. Two of these mechanisms will be needed as the two rows of needles are connected by two adjusting bridges. The track is marked with a ruler so the surgeon can easily adjust the device to the correct dimension. The length of the device adjusts by snapping on extra needles. The main device has a

length of 6 cm. Each extra snap-on needle adds a length of 1 cm giving the length a range of 6-12 cm. Making the extra pieces in 1 cm intervals allows the needles to remain less than 1 cm apart. This device is more complicated to construct than the first design, but it allows the surgeon to adjust the device more specifically to each patient. This design also requires the user to keep track of extra pieces.

Design 3: 2D Adjustable, Spring Mechanism

The third design (see figure 7) is similar to design 2, but utilizes different adjustment mechanisms. The width will be adjusted using the same track described in design 2, but it uses a spring loaded push-button mechanism as a lock instead of a screw.

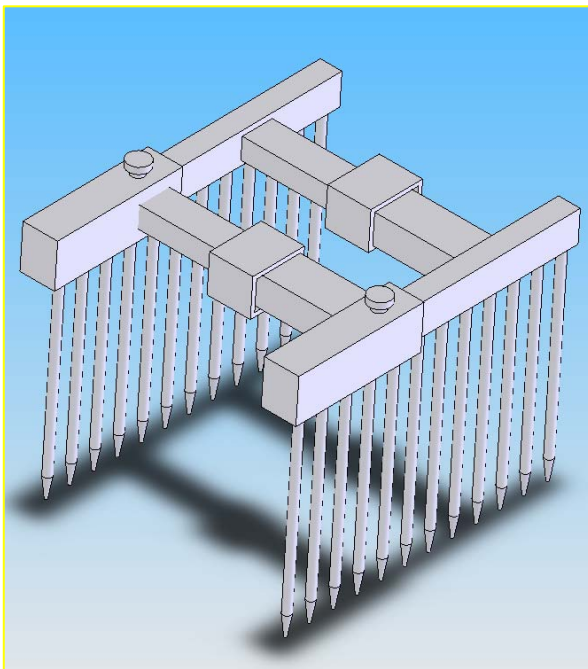

Instead of a smooth track like design 2, the track is notched. When the button is pushed down, a spring is compressed and a tab is pushed out of the notches that serve as the locking mechanism. When the button is released, the tab falls back into the notches. The width adjusts within a 5-10 cm range. The buttons on the bridges face away from the device

Fig 7: 2D adjustable, push-button design

(towards the head and feet of the patient). This will make it possible for surgeon to push both buttons at the same time with one hand and use other hand to slide the device to the desired width. The length of this device uses a modified screw mechanism described in design 2. Within the bars running length-wise, the needles are spaced by compressed springs. When the screw is released and the length is adjusted, the springs will compress or lengthen to accommodate the 1 cm needle spacing requirement. The construction of this design is more complicated than designs 1 and 2, but it allows the surgeon even more accuracy when adjusting the device to fit the patient. This design also does not require storage of extra pieces.

Design Matrix

In order to choose a design to pursue, we constructed a design matrix (see figure 8). We decided the most important criterion was being able to easily adjust to the patient. We also accounted for ease of use, ease of construction, ease of sterilization and cost. Each design was scored on a weighted scale of 1 (worst) -5 (best).

	Weight	Design 1:No moving parts	Design 2: Snap-on pieces	Design 3: Push-button
Ability to adjust to patient	0.4	1	4	5
Ease of use	0.25	4	4	3
Ease of Construction	0.2	4	3	3
Ease of sterilization	0.1	5	4	4
Cost	0.05	3	3	3
Total	1.0	2.85	3.75	3.9

Fig 8: Design matrix

After carefully weighing the design constraints, cost and available time, we decided to pursue design 3: 2D Adjustable, Spring Mechanism. Although this design involves complicated mechanisms, the width and length of the device can be adjusted without any extra components, such as snap-on pieces.

Final Design

Construction - Prototype 1

Upon further research into the adjustment mechanism of our chosen design, we realized construction would be much more complicated than originally thought. In order to finish a prototype on our timeline, we decided to focus only on making the device adjustable width-wise. For construction purposes, we also decided to adjust the width using either a pin or a screw mechanism.

For the first prototype, parts 1 and 2 are made of aluminum and for parts 3 and 4 are made of steel (Figure 9). The spikes have a diameter of 0.4 cm and a length of 10 cm. The centers of the spikes are 1 cm apart. The width is adjustable between 8 cm and 12 cm. In order to make the spikes, a steel rod was sundered to make a pointed end. The rod was cut to 10.5 cm to allow 5 mm of the spike to be inserted into part 1. Each side of the device contains 8 spikes (total of 16). To keep the spike inserted in to the part 1, holes were drilled with slightly smaller drill bit than the diameter of the spike. The spikes were forced into the hole.

For part 3, a square, hollow piece of steel was cut to a length of 6.5 cm. One end was filled with a 6 mm thick piece of steel in order to make a thread for the bolt. For part 2, a round aluminum rod was cut to a length of 6 cm. A thread for the bolt was made on one end. Four holes were drilled on part 2 and one hole was drilled on part 3 to allow the device to adjust to different widths and be locked with a pin. The adjusting parts 2 and 3 were connected to the part 1 with bolts.

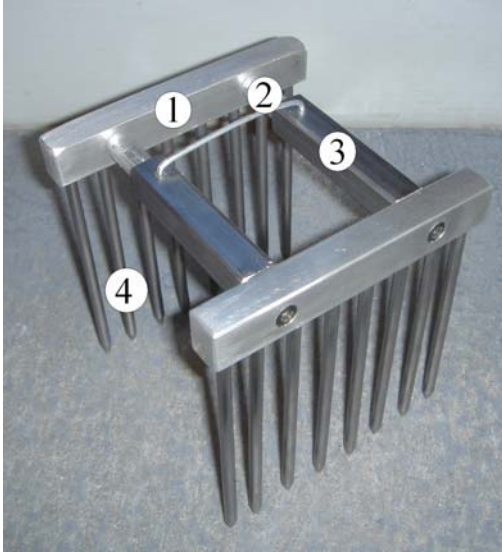

Figure 9: Prototype 1
 1) Side beams. 2) Inner cross bar. 3) Outer cross bar. 4) Spikes.

Construction – Prototype 2

Prototype 2 is made entirely of stainless steel. This device has the same dimensions as the first, but a few areas have been improved. First, the material used for the spikes in the first prototype is softer than stainless and bends under little pressure. Because of this, the row of spikes in final product looked slightly uneven. Secondly, the screws used to connect the sidebars to the cross beams in the first prototype created more nooks for debris and bacteria to fill during surgery and might not be easily sterilized. These unwanted gaps could be removed by welding the crossbeams and sidebars. Lastly, the second prototype uses a screw adjusting mechanism instead of a pin. This allows for a wider variety of widths as it is not dependent on holes drilled at set measurements. It also eliminates extra holes in the device that could trap debris and bacteria.

Construction techniques for the second prototype were very similar to the first. The welding, however, created problems. The wrong type of stainless steel was sent to us and is not suitable for welding.

Material Choice

Stainless steel is durable so the needles will not dull excessively. This material is also heavy enough so the device will stay in place during surgery. Many other medical tools and devices are constructed from stainless surgical steel so the same cleaning procedure would be able to be applied to this device.

Future Work

First of all, the stainless steel prototype assembly needs to be completed. Once this is done, the device should be tested on animal tissue. The device needs to be tested to ensure the spikes are of appropriate sharpness. This means they will penetrate fat tissue easily but not significantly penetrate muscle. The device should also be tested for stability. This involves placing the device into a layer of fat tissue and making sure that it stays in place with little outside force, does not tip from side to side and the adjustment mechanism stays locked at a fixed width. Once certain the device is safe and reliable, human testing should be done. The stainless steel prototype feels slightly heavy in the hand so if testing reveals that the device exerts too much force on the patient, lighter materials may need to be researched.

The current sliding pin adjustment mechanism is a little awkward and difficult to adjust. It would be desirable to develop a more ergonomic mechanism that can be adjusted with one hand. This might be accomplished using the push-button mechanism discussed in alternative design 3.

Finally, a custom metal working factory that would be able to mass produce this device needs to be found. Both prototypes were completely machined by hand. Not only

was this process time consuming, but there is more room for error and dissimilarities will develop among the devices.

References

Bostwick, J. *Aesthetic and Reconstructive Breast Surgery*. Mosby. St. Louis. 1983. pp.

138-143, 156-158, 184-188.

Spear, S.L. (editor). *Surgery of the breast*. v. 2. 2006.

APPENDIX 1: Product Design Specifications

Team Name

Kuya Takami, Laura Bagley, Nathan Werbeckes, Joseph Yuen

Problem Statement:

Our goal is to design a device that will hold the breast pedicle, which supplies blood and nerves to the nipple, in place during breast reduction surgery. The device will also protect the pedicle by surrounding it with spikes that mark where the surgeon will cut to remove the breast tissue.

Client Requirements:

- Device should be able to be adjusted for each patient
- Device should be accurate and reliable
- Device should perform current standard procedure
- Safety of patient and surgeon should be maintained
- Device should be able to be sanitized or disposable

Design Requirements:

1. Physical and Operational Characteristics

- a. Performance Requirements
 - Very light loading capacity
 - 100-150 surgeries performed per year
- b. Safety
 - Sharp enough to pierce breast tissue but not harm ribs or internal organs
 - Storage should cover sharp spikes
 - Able to be sterilized
- c. Accuracy and Reliability
 - Absolute accuracy not needed
 - 5-10 mm accuracy
- d. Life in Service
 - Unknown at this point
 - Account for dulling of spikes
- e. Shelf Life
 - Unknown at this point
 - Need some sort of container for storage and safety (sharp spikes)
 - General storage container okay
- f. Operating Environment
 - Used by a surgeon in a surgical environment
- g. Ergonomics
 - Should be able to be operated by one person
 - Handle/gripper needed
- h. Size
 - Width adjustable between 5 cm and 10 cm

- Length adjustable between 6 cm and 12 cm or non-adjustable 8 cm to 10 cm
- Height approximately 10 cm
- Spikes 3-4 mm in diameter
- Spikes approximately 1 cm apart
- i. Weight
 - Light enough to be handled easily by surgeon
 - Heavy enough to stay in place while surgeon makes cuts
 - No specific requirement
- j. Materials
 - Stainless steel
 - Minimize dulling of spikes
 - Entire device should be same material (preferably)
- k. Aesthetics
 - Used in surgery so aesthetics are not a major concern

2. Production Characteristics

- a. Quantity
 - One prototype
- b. Target Product Cost
 - Actual product cost unknown
 - Project budget ideally under \$500, under \$1000 okay

3. Miscellaneous

- a. Standards and Specifications
- b. Customer
 - Would like two working devices on hand
- c. Patient-related concerns
 - Device sterilized between surgeries
 - Needles preferably stop at muscle, but it is acceptable to stop at ribs
- d. Competition
 - No similar device on market