

# BME 301 (BIOMEDICAL ENGINEERING DESIGN)

*Project #22: Umbilical Cord Model for Umbilical Vein Catheterization Training*

## FINAL REPORT

May 07, 2008

### **TEAM MEMBERS:**

Ann Sagstetter (Team Leader)

Kelvin Ng (Communicator)

Megan Britson (BSAC)

Fan Wu (BWIG)

### **CLIENT:**

Dr Julie Kessel

*Department of Pediatrics, UW-Madison*

### **ADVISOR:**

Professor Brenda Ogle

*Department of Biomedical Engineering, UW-Madison*

---

**Abstract:** Current models used in umbilical vein catheterization training have been deemed inadequate at simulating the actual procedure. To provide a more realistic experience for the trainees, a cuff mechanism was designed last semester and was proven to surpass the current models in terms of the ability to incorporate and stabilize a real umbilical cord. This semester, the project focuses on the design of a manufacturable external support that mimics the infant's abdomen and can be integrated with the cuff mechanism. A silicone rubber cast model have thus been devised and proven by surveys to be clinically more welcome than the current models. The project now aims to present the prototype to suitable manufacturer in a comprehensive manufacturing package.

---

---

## Table of Contents

Background Information	
<i>Anatomy of the Umbilical System</i> .....	4
<i>Umbilical Vein Catheterization (UVC)</i> .....	5
<i>UVC Training by the American Academy of Pediatrics</i> .....	5
Market Research.....	6
Problem Statement	
<i>Client's Requirements</i> .....	7
<i>Ethical Considerations &amp; Human Factors</i> .....	7
Project History	
<i>The Gel Model</i> .....	8
<i>The Cuff Model</i> .....	9
<i>Model Testing</i> .....	9
<i>Plans for This Semester</i> .....	11
External Support Design	
<i>The Artificial Skin Model</i> .....	12
<i>The Bean Bag Model</i> .....	13
<i>The Rubber Cast Model</i> .....	13
<i>Design Matrix</i> .....	13
Experimental Results.....	14
Manufacturing Package	
<i>Standard Operating Procedures &amp; Technical Drawings</i> .....	16
<i>Testing Results</i> .....	16
<i>Production Cost Estimation</i> .....	17
<i>Market Demand Estimation</i> .....	17
Future Work & Potential Difficulties.....	18
Credits.....	18

References.....	19
Appendix A: Product Design Specifications.....	20
Appendix B: User Manual.....	23
Appendix C: Technical Drawings.....	33
Appendix D: Project Expenditure.....	34
Appendix E: Time Contributions of Individual Members.....	35

## Background Information

### *Anatomy of the Umbilical System*

Before delivery, the fetus is connected to the mother through the umbilical cord and the placenta. A healthy umbilical cord contains 1 central vein which transports oxygenated blood from the placenta to the fetus, and 2 umbilical arteries which transport deoxygenated blood in the opposite direction. Structural differences between the umbilical vessels include lumen size and wall thickness (Figure 1). In the umbilical cord, the umbilical vessels are surrounded by Wharton's jelly, a gelatinous substance that is composed of mostly hyaluronic acid, some collagen and mesenchymal stem cells. Functionally, the Wharton's jelly provides structural support and protection for the umbilical vessels, regulates blood flow, and stores chemicals upon the onset of labor. The allantoic duct, though running in parallel with the umbilical vessels within the umbilical cord, is a remnant of embryonic development and eventually becomes a vestigial structure. Besides the allantoic duct and the umbilical vessels, other macrostructures in the umbilical cord such as nerves and lymphatic vessels are absent.<sup>[1]</sup>

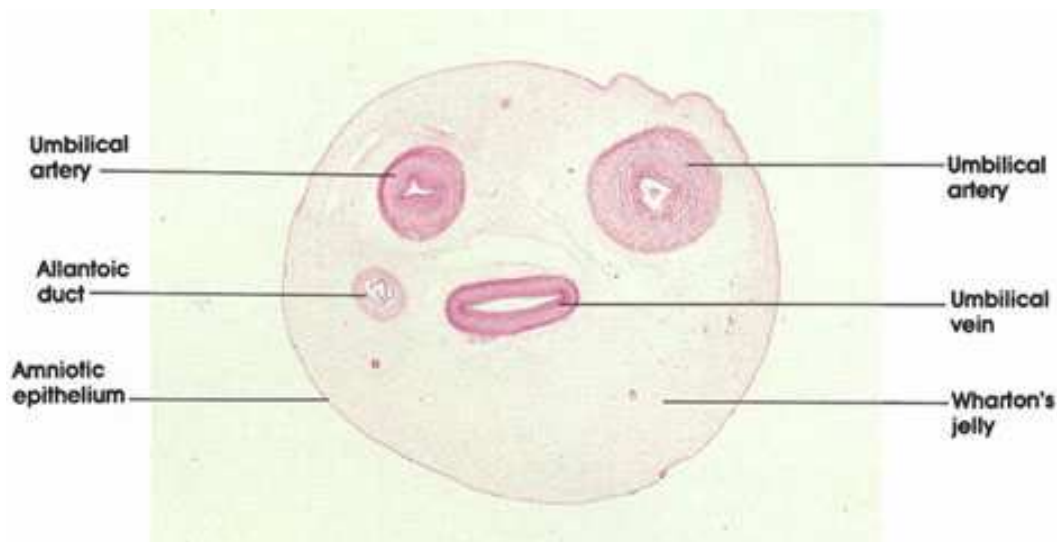

**Figure 1:** Histological cross section of an umbilical cord revealing the relative positions of the umbilical arteries and veins, and the surrounding Wharton's jelly.<sup>[1]</sup>

From the placenta to the umbilicus, the umbilical vessels intertwine in a helical fashion, and diverge upon entry into the fetal abdominal cavity (Figure 2)<sup>[2]</sup>. The umbilical arteries turn inferiorly towards the legs and course around the urinary bladder before joining the internal iliac arteries (and eventually the aorta) approximately at the first sacral vertebral level<sup>[3]</sup>. On the other hand, the umbilical vein ascends into the liver and bifurcates at the transverse fissure, branching into the right hepatic lobe and the inferior vena cava<sup>[4]</sup>.

In a full-term neonate, the umbilical cord is on average about 50 cm long and 2 cm in diameter. The lumen of an umbilical vessel is approximately 1 to 2 mm in diameter.<sup>[2]</sup>

## *Umbilical Vein Catheterization (UVC)*<sup>[6,7]</sup>

During delivery, once the neonate is able to breathe independently, the umbilical cord is doubly clamped at about 2 to 3 cm from the neonatal end and severed between the clamps. The position at which the cord is severed heavily depends on the wellbeing of the neonate. If the need for catheterization through any of the umbilical vessels is foreseen, the cord is cut further away from the neonatal end, leaving a longer umbilical stump. Once the cord is severed, the umbilical stump that remains takes up to 3 weeks to dehydrate and self-amputate.

UVC is called for when the neonate requires medical intervention via venous access, whether or not it is an emergency. Examples of such situations include shock, cardiopulmonary failure and hypoglycemia, all of which can happen during or after delivery. Venous access allows clinicians to deliver intravenous drugs and perform blood transfusions. Having no innervation, the

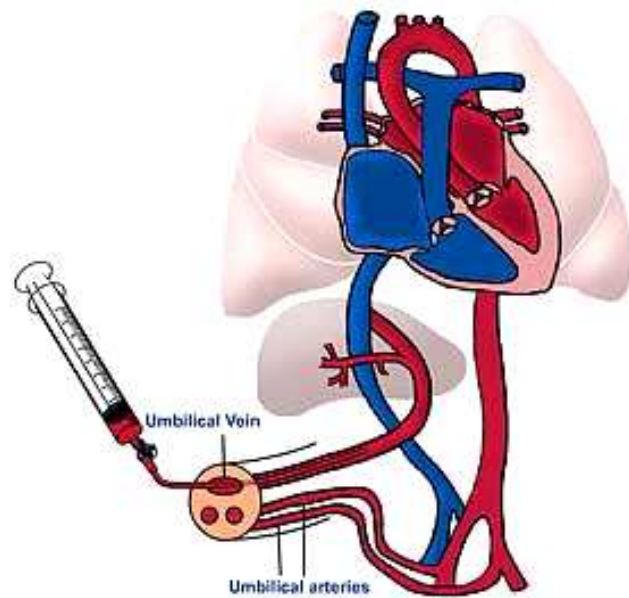

**Figure 2:** Schematic of the course of the umbilical vessels upon entry into the abdominal cavity and the insertion of an umbilical vein catheter.<sup>[5]</sup>

UV provides the most direct and painless intravenous route without the need to access intact systemic veins and damage them unnecessarily. However, due to the rapid deterioration of the umbilical stump, UVC can only be used temporarily while new routes of venous access are being identified.

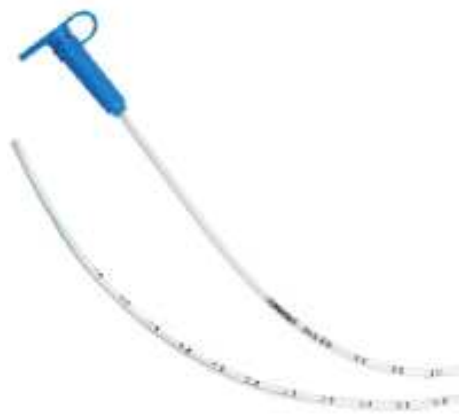

**Figure 3:** An umbilical vein catheter.  
(3 French = 1 mm)

During UVC, the clinician carefully inserts a 3.5- or 5-French catheter (Figure 3) into the UV while an assistant stabilizes the umbilical stump with forceps. The clinician then navigates through the UV towards the liver, usually up to a depth of about 5 cm beyond the umbilicus. To verify the depth of insertion, the clinician refers to the graduations on the catheter and regularly draws back on the catheter syringe to observe the presence of blood. If blood can be drawn back, the clinician stops advancing and performs the necessary medical procedures.

## *UVC Training by the American Academy of Pediatrics*<sup>[5,7]</sup>

Via the Neonatal Resuscitation Program (NRP), the American Academy of Pediatrics trains thousands of clinicians about 35,000 times a year globally to hone their UVC skills. The current accepted training model is the baby bottle model. It consists of a bottle of Pedialyte solution and a cap of a standard milk bottle. The tip of the cap is cut to expose a hole through which a fresh umbilical cord can be inserted, and the Pedialyte solution is dyed red using commercial food coloring (Figure 4a). The umbilical cord is subsequently tied as required by the actual catheterization protocol (Figure 4b), and catheterization proceeds (Figure 4c). Although tying helps to stabilize it, the cord readily slips in and out of the bottle once the

trainee starts to catheterize it. This increases the tendency of the trainee to apply more force while catheterizing, which may eventually puncture the cord (Figure 4d). Clearly, such cord instability in the NRP baby bottle is not at all representative of the actual procedure and hinders training progress.

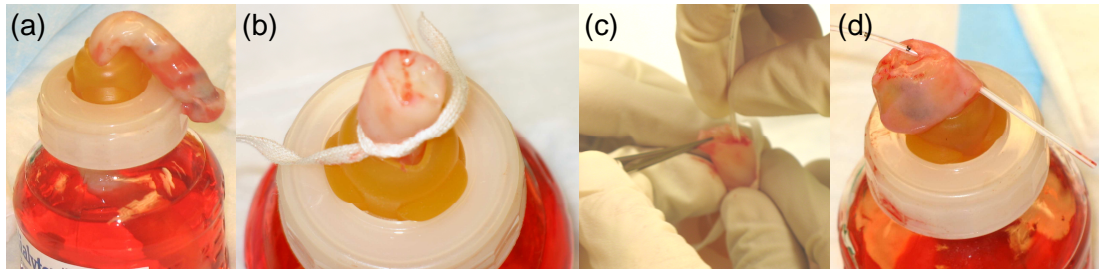

**Figure 4:** (a) The NRP baby bottle model. (b) Tying the cord offers some stability. (c) Assistance is needed during catheterization as the cord slips in and out of the bottle. (d) Punctured cord due to aggressive handling.

## Market Research

There are 2 models existing in the current market that aim to provide a better simulation model for the NRP UVC training. One of them is an artificial umbilical cord made from vinyl tubing (Figure 5a). This model can be homemade at less than \$5 and does not require expertise for assembly.<sup>[8]</sup> Friction between the vinyl tubing and the milk bottle cap is considerably higher than that between Wharton's jelly and the milk bottle cap, hence providing sufficient stability for use in UVC training.

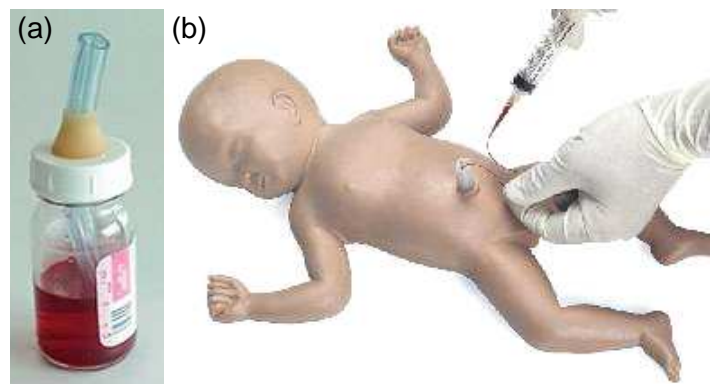

**Figure 5:** (a) Using the vinyl umbilical cord with the NRP baby bottle model<sup>[8]</sup>. (b) “Baby Umbi” from Laerdal<sup>[9]</sup>.

The other model is “Baby Umbi” from Laerdal (Figure 5b). Without tax, the model costs \$416 per doll and \$56 per set of 3 artificial umbilical cords.<sup>[9]</sup> Besides offering adequate stability during UVC training, the model has an additional dimension of simulation by providing an infant substitute. This is beneficial as the trainee is now able to support his or her wrists on the doll's abdomen like what is done in the actual procedure. The doll also permits a more realistic visual experience.

The 2 existing models indeed resolve the issue of cord stability posed by the NRP baby bottle. However, one major setback of these models is the absence of a real umbilical cord. Regardless of how stable or realistic the models might be, using real umbilical cords is critical to the trainee's learning. In particular, plastic tubing does not possess the soft, slimy texture of the Wharton's jelly and the intertwining anatomy of the umbilical vessels. More resistance is also encountered when catheterizing a plastic tube as the friction between the plastic tube and the catheter is much higher than that between a real umbilical vein and the catheter. It is thus apparent that the existing models are inadequate substitutes for the NRP baby bottle model.

## **Problem Statement**

This project aims to provide a better model for the NRP UVC training and entails 2 short-term goals and 1 long-term goal. The short-term goals include the design of a functional mechanism that incorporates and stabilizes a real umbilical cord, and the design of an external structure that mimics the infant's abdomen. Both components should be complementary and able to be integrated into a single model. These goals essentially combine the strengths of the existing models. On the other hand, the long-term goal is to utilize the model in the NRP. To do so, the model must first undergo practical testing to prove its advantage over the baby bottle model and eventually be manufactured in bulk. Manufacturability must therefore be taken account in the model design.

## ***Client's Requirements***

There are several specific requirements put forth by the client. Firstly, fresh umbilical cords must be used within 1 to 2 days after birth, in the light of their rapid deterioration *ex vivo*. The dimensions of the stabilizing mechanism must allow for at least 2 cm of cord extruding beyond the "umbilicus" and 3 cm into the "abdomen", and must also accommodate various cord sizes. The internal segment of the cord can be treated as systemic blood vessels, so there is no need to mimic the internal abdominal anatomy. As umbilical cords are biohazards, materials used in the model must be disposable.

Next, the stabilizing mechanism must withstand the upper limit of mechanical forces involved during UVC training. This limit should be low since trainees are expected to practise cautious handling during UVC. The mechanism should also include a blood reservoir from which blood-mimicking solution can be drawn for verification of catheter depth. Meanwhile, the external structure needs to fit the dimensions and weight of the infant's abdomen. Its texture must resemble human tissue and should ideally be opaque. Although the entire model will be disposed after usage, it should be durable at least for the period of use.

Lastly, the final model should be user-friendly such that minimal preparation effort is required on the user side. It must also perform better than the existing models, and yet remain easily manufactured.

## ***Ethical Considerations & Human Factors***

To preserve donor confidentiality, umbilical cords must be obtained anonymously. Morally, the cords must be treated with respect and should not be misused. Instructions on using the model should be provided if it is not obvious how the model can be used. Meanwhile, potential dangers of the model must be made clear to the user and manufacturer. Both pieces of information can be provided in a comprehensive user manual. From the engineering perspective, the design must take into account how the model may be misused and try to minimize it by considering factors of safety. Predictable ways of misuse that are inevitable should be listed as warnings in the user manual.

With regards to intellectual property, it is necessary to keep the design as original as possible; otherwise, respective sources must be properly cited. Technical drawings, dimensions, test results, cost estimates, and other quantitative data must be reported accurately and honestly. Administratively, usage and construction of the model must be compatible with prevailing training protocols and manufacturing guidelines. If necessary, approval should be sought from the American Academy of Pediatrics, the Food & Drug Administration, the Institutional Review Board, and other relevant authorities.

## Project History

Both short-term goals were pursued in the previous semester. An external support derived from a foam football was created to mimic the infant's abdomen. A 1.75"-diameter hole is drilled into the football to contain the stabilizing mechanism and the umbilical cord. At the same time, two models were created to incorporate and stabilize real umbilical cords, namely the gel model and the cuff model.

### *The Gel Model*

The gel model utilizes two 1.75"-diameter Playtex liners. One liner is used to contain the umbilical cord, and its inner surface is coated with a 2 cm by 13 cm strip of adhesive sandpaper just below the brim. A 7-cm segment of umbilical cord is then vertically suspended in the middle of the liner with a weight tied to its lower end to straighten it. The weight is chosen such that overstretching of the cord is prevented. Meanwhile, Knox gelatin is dissolved in boiling water at a concentration of three packets per 150 ml of water. The solution is continuously stirred to ensure complete dissolution and left to cool to room temperature. It is then poured into the sandpaper-coated Playtex liner leaving approximately 2 cm of the cord exposed in air. Finally, the entire liner is placed in a large airtight bag and cooled at 2°C overnight to allow the gelatin to set.

The liner is removed from the refrigerator on the following day. Using a scalpel, the liner is cut to detach the weight and expose a cross section of the cord. The other liner is then filled with 50 ml of water and a few drops of red dye, and the sandpaper-coated liner with the cord and gelatin is inserted into it (Figure 6a). The entire unit of 2 liners is finally inserted into the external support until the lips of the liners touch the support (Figure 6b). This completes the gel model.

As the umbilical cord is fixed in place by the gelatin and further enhanced by the sandpaper (which provides additional adhesion between the liner and gelatin), the gel model greatly supersedes the NRP baby bottle model in terms of the stability of the cord. Not only does it prevent rotation and translation of the cord during catheterization, it even resembles an umbilicus due to the skin-like texture of the solidified gelatin. Also, a variety of cord sizes can be accommodated. Finally, the incorporation of real umbilical cords renders the gel model superior to existing models in the market.

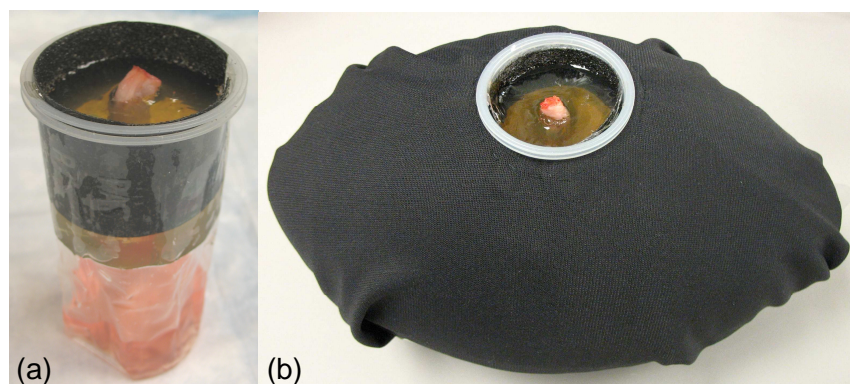

**Figure 6:** (a) Stabilizing mechanism of the gel model. The cord specimen is embedded in solidified gelatin. (b) The completed gel model.



## *The Cuff Model*

The major functional component of the cuff model is a Philips Neonate 3 blood pressure cuff, which has a maximum diameter of 3.18 cm and collapses upon complete inflation such that opposite sides of the cuff's inner surface are in contact with each other. The cuff is prepared by gluing 4.1 cm by 0.3 cm strips of sandpaper to its inner surface in groups of 3. The strips are regularly spaced at about 0.2 cm between each other and each group is placed at regions of the cuff's inner surface that do not crease upon inflation. Such a placement ensures that the cuff inflates into a square shape so that the umbilical cord is in optimal contact with the frictional surfaces.

The modified cuff is then secured inside a Medela 80-ml SpecialNeeds Feeder bottle by applying a cyanoacrylate-based adhesive between the cuff's outer surface and the bottle's inner surface. A 3.57 mm-diameter hole is drilled 4.5 cm from the upper lip of the bottle to allow the cuff's air tube to exit the bottle without blocking the lumen. Once the air tube is passed through the hole, it is attached to a 50-ml syringe which serves as a control for the cuff's inflation (Figure 7a). 25 ml of water and a few drops of red dye are then added to the bottle to form the blood reservoir, and the entire unit is inserted into the external support (Figure 7b). To accommodate the air tube, a 3/8"-hole is drilled into the external support. This completes the cuff model.

Like the gel model, the cuff model performs better than the NRP baby bottle model and the existing models in the market in terms of cord stability and realistic simulation. Various cord sizes can also be accommodated. However, the major difference is that the cuff model does not engage the user in preparatory work in order to use it.

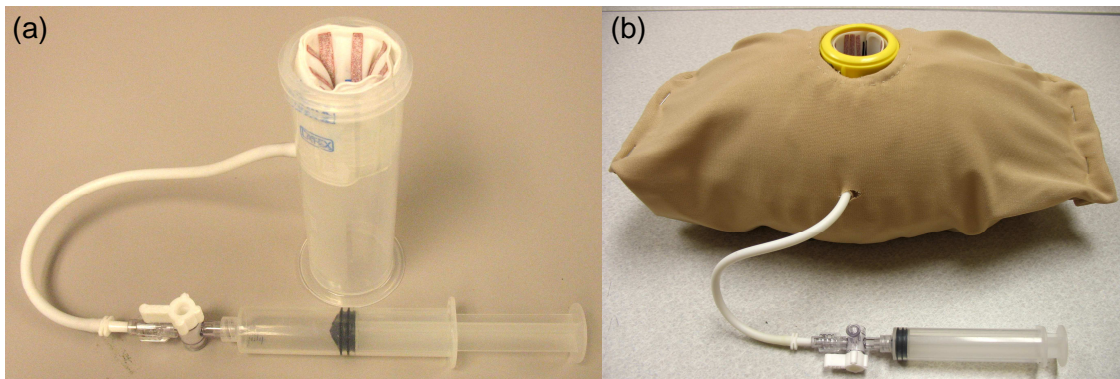
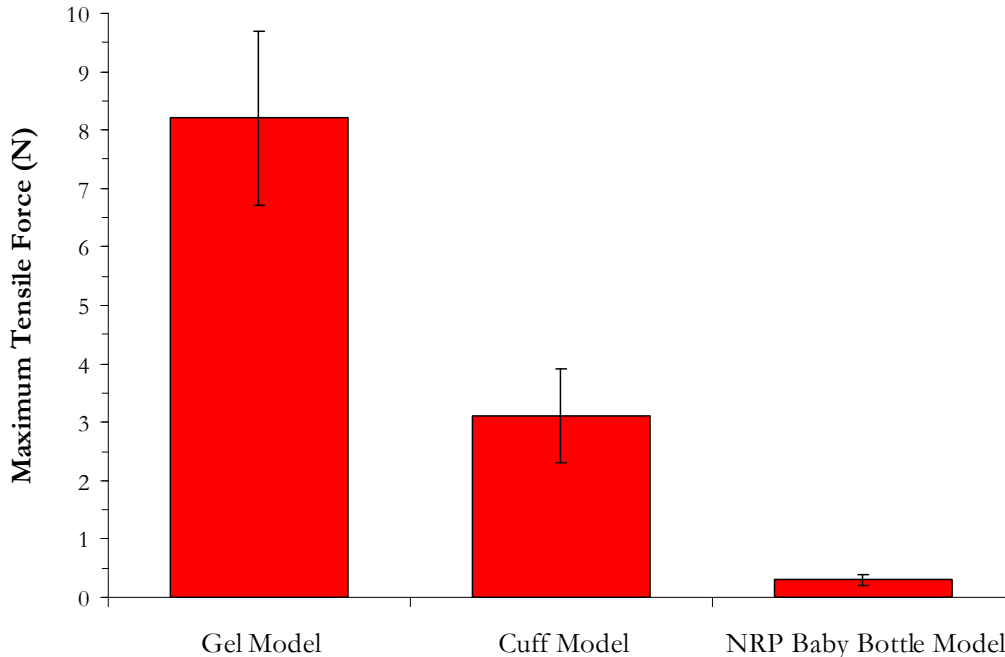

**Figure 7:** (a) Stabilizing mechanism of the cuff model. The cord specimen can be held in place by inflating the sandpaper-lined blood pressure cuff using the syringe. (b) The completed cuff model.

## *Model Testing*

Without quantitative assessment, it was difficult to determine which model was actually better as both models satisfied the design requirements. More importantly, objective evidence was necessary to prove that the models were indeed better than the NRP baby bottle model. Hence, two types of tests were performed. The first was a tensile test in which a cord specimen was stabilized using each model, and a Newton meter was used to uproot the cord. The maximum force required was recorded and averaged over several cords. The second test put the models through actual catheterization and the average success rate was computed.

To minimize the effects of confounds such as variability in the cord tissue and the coiling of the umbilical vein, each umbilical cord was cut into 3 equal segments so that every cord was tested in each model. Results are shown below.



**Figure 8:** Tensile test results. Figures reflect the average maximum tensile force required to uproot a cord segment from each model. (Sample size = 5)

MODEL	SUCCESS OF CATHETERIZATION
Gel Model	100%
Cuff Model	67%
NRP Baby Bottle Model	0%

**Figure 9:** Catheterization test results. Figures reflect the percentage of cord segments that could be successfully catheterized. (Sample size = 3)

Clearly, both models performed better than the NRP baby bottle model, and the gel model was superior to the cuff model in both tests. However, it was noted that the cuff model has a greater commercial potential as it is much more user-friendly in terms of its preparation and can be repeatedly used since the cord is not permanently fixed to it. Such manufacturability was not observed in the gel model. Hence, further testing was performed to assess if the characteristics of the cuff model are sufficient despite being weaker than those of the gel model.

One hypothesis to why the cuff model underperformed in the catheterization test was that the pressure might be too high for successful catheterization, as the umbilical vein could be occluded. Hence, an additional test involved catheterizing the same cord under different pressures, and repeating the same procedure on different cords. Out of 3 cords, the same success rate as that in Figure 9 was observed. However, it was noted that the “unsuccessful” cord had multiple blood clots which might have hindered catheterization. More importantly, the cuff pressure seemed to have no effect on the success rate, as all “successful” cords remained catheterizable between pressure limits of the cuff. There was also no movement of the cords throughout the test, implying that even though the cuff model is weaker than the gel model in terms of tensile stability, it is strong enough to sustain the forces involved during cord handling. Pending experiments to substantiate the above speculations (refer to page 15), the cuff model was selected against the gel model, fulfilling one of the short-term goals.

### ***Plans for This Semester***

The focus of this semester is to pursue the remaining 2 goals, namely external support design and product manufacturing. Although brainstorming for the external support has begun last semester, it was not the project’s focus then, hence the foam football served as a substitute all along. The foam football was not ideal because its shape and texture cannot be modified, being a commercial product. This semester, the primary objective pertaining to external support design is to create a better external support that closely mimics the texture, shape, size and weight of the infant’s abdomen, and can be easily manufactured. Meanwhile, the primary objective pertaining to product manufacturing is to find out the relevant manufacturing standards, fulfill them and ultimately present the product to a suitable manufacturer. This can be done by devising a manufacturing package that contains all the information a manufacturer needs to assess the product.

## **External Support Design**

Besides the client’s requirements, there are certain engineering and manufacturing concerns that are involved when designing the external support. They can roughly be divided into 3 categories: physical and operational characteristics, production characteristics, and miscellaneous. Together with the client’s requirements, these are summarized in the Product Design Specifications available at Appendix A.

The physical and operational characteristics provide guidelines on how the external support must look and function in a predetermined environment (in this case, clinical or laboratory settings). Firstly, the support must be either disposable or sterilizable since its usage involves physical contact with blood and human tissue. However, as sterilizable materials are much more restricted in terms of their moldability, the design will focus primarily on disposable materials. Consequently, the support should withstand usage for at least 2 hours but have a shelf life of at least 2 years. Mimicry of the abdominal texture must be achieved without compromising the functionality of the cuff model. In other words, the external support must be compatible with the cuff model. As the average weight of a newborn is 3.4 kg<sup>[10]</sup>, the external support is expected to weigh between 1 kg to 2 kg, given that only the abdomen or torso will be simulated. It should be around 30 cm long, 15 cm wide, and 5 cm deep to accommodate the cuff model.

The production characteristics provide information on the quantity and target production cost of the external support prototype due by the end of this semester. For a target retail price of \$90 at maximum, one reproducible model shall be constructed at a cost below \$15, considering only raw materials.

The miscellaneous category covers all requirements that did not fit into the categories above. Here, the only requirement is that the external support must comply with manufacturing standards and the NRP guidelines.

Summing all the above requirements, the design assessment criteria for the external support can be broadly classified as follows:

1. **Appearance & texture:** This refers to the model's ability to mimic the infant's abdomen in terms of texture, visual appeal, color and shape. It is the most important criterion as it is crucial at providing a realistic visual and tactile experience to the user.
2. **Ease of construction:** This refers to the complexity of the construction procedure and the availability of materials. Ideally, the materials and methods used to build the model should be available on the manufacturing line, yet accessible on campus. The incorporation of the cuff model into the support should also be simple.
3. **Reproducibility:** This refers to how easy it is to reconstruct the original model with minimal errors and variability. The construction or reconstruction process should also allow easy backtracking and repair should accidental defects be detected before completion of the product.
4. **Durability:** This refers to how long the model can be stored without significant degradation and how much it can endure the stresses involved during handling. It is the least important criterion as the usage period is only 2 hours and the users are expected to handle the model carefully.

### *The Artificial Skin Model*

The artificial skin model is composed of 2 elements: a core made of a tough, deformable material such as high-density foam, and an outer layer made of a soft, elastic material such as soft rubber (Figure 10). The main advantages of this model is the ease of construction and reproducibility as the core and external layer can be easily purchased, drilled and adhered together. It is however not perfect as the interface between the 2 materials presents a source of mechanical weakness and construction errors. It may also be difficult to select 2 materials that give the ideal texture and respond equally to the same adhesive. Nevertheless, these weaknesses are not significant, hence the model is still a strong candidate.

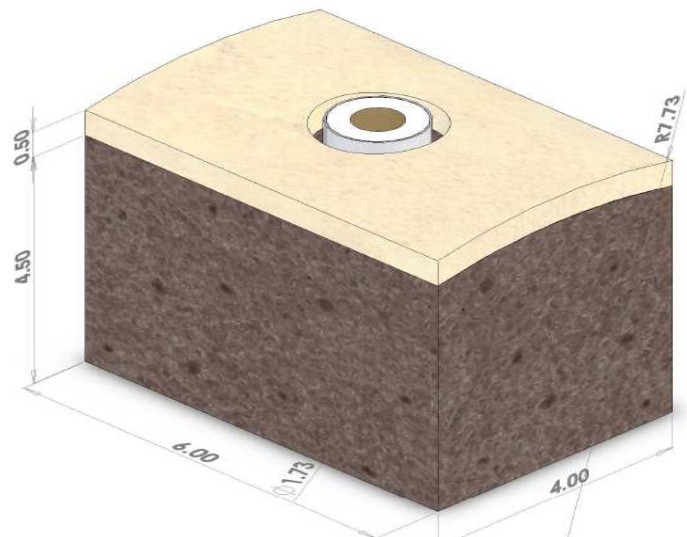

**Figure 10:** A representative portion of the artificial skin model. The thinner top layer is made of low-density material while the thicker core is made of high-density material. All measurements are in inches.

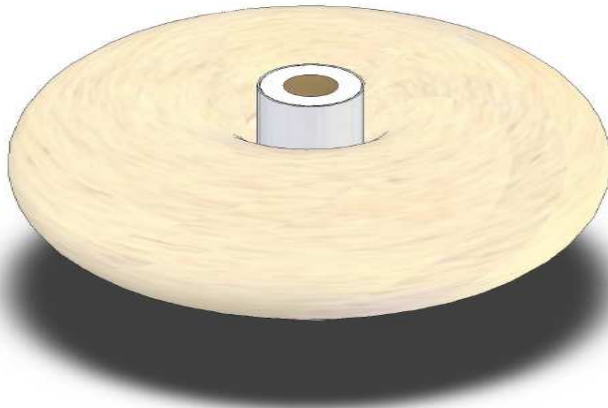

**Figure 11:** The bean bag model. The “bean bag” wraps around the cuff model and is coated with a layer of soft polymer. The outer diameter of the model is about 30 cm.

### *The Bean Bag Model*

The bean bag model utilizes a donut-shaped cushion that is stuffed with beads, sand, or any other particles and wraps around the cuff model (Figure 11), based the concept of a bean bag. The cushion fabric is additionally coated with a layer of soft polymer such as rubber to mimic skin texture. The motivation behind this model is to produce a similar compression when pressed as does the infant’s abdomen. Compared to the artificial skin model, this model is weaker in all aspects. Not only does it resemble the infant’s abdomen less, it is more difficult to alter its appearance and texture. Sewing renders it less reproducible, less easy to construct, and less durable though it may be sufficient to endure the usage period.

### *The Rubber Cast Model*

The rubber cast model is simply a block of soft polymer molded to accommodate the cuff model (Figure 12). Compared to the other models, it is the most reproducible as only one step is involved in the construction process. Since the polymer density can be controlled, there is a lot of flexibility in appearance and texture. However, a certain level of expertise may be required to mold such polymers, hence this model fares less on the ease of construction than the artificial skin model. Nevertheless, if properly molded, the model has little or no points of weakness.

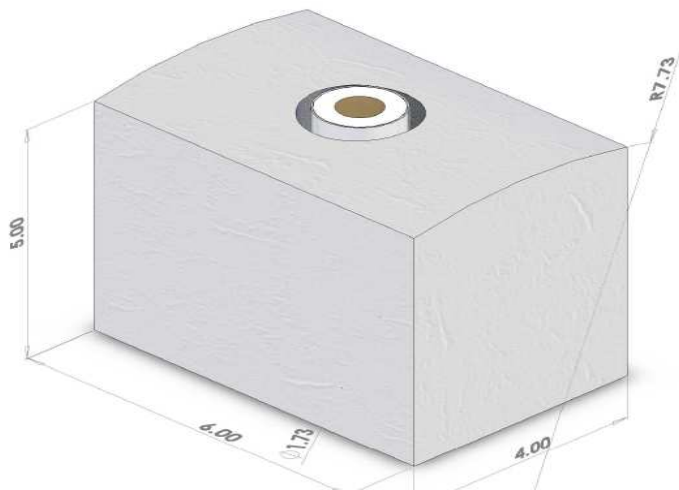

**Figure 12:** A representative portion of the rubber cast model. The entire model is made of a single soft polymer. All measurements are in inches.

### *Design Matrix*

To identify the best model to pursue, the design criteria are weighted in percentages according to their importance and relevance to the design requirements. Each model is then evaluated and given a score out of 100 for each criterion. The score for each criterion is multiplied by the corresponding weight and added up to yield the total score for that model. Based on the design matrix (Figure 13), both the artificial skin and rubber cast models are deemed equally well and are chosen for future work.

CRITERIA	WEIGHT	ARTIFICIAL SKIN MODEL	BEAN BAG MODEL	RUBBER CAST MODEL
Appearance & Texture	40%	80	70	90
Ease of Construction	30%	90	60	80
Reproducibility	20%	90	50	100
Durability	10%	80	70	90
<b>TOTAL</b>	<b>100%</b>	<b>85</b>	<b>63</b>	<b>89</b>

**Figure 13:** Design matrix showing the weight of each design criterion and the scores of each model. Both the artificial skin and rubber cast models were chosen for future work.

## Experimental Results

As both the artificial skin and rubber cast models involve polymer selection, 2 types of polymer – Smooth-Sil 910 silicone rubber and Vytaflex 10A polyurethane rubber – were bought from Smooth-On, Inc. ([www.smoothonsecure.com](http://www.smoothonsecure.com)) and tested for their efficacies at texture mimicry. As a preliminary step, the models were constructed with simple geometry and tested by touch to assess the degree of mimicry. Specifically, the artificial skin model was made by coating a rectangular foam block with liquid polymer, while the rubber cast model was made by pouring liquid polymer into a rectangular tupperware. Results based on the artificial skin model revealed that silicone rubber was a better choice (Figures 14a-b).

The cuff mechanism was incorporated when constructing the rubber cast model to assess their compatibility with each other (Figure 14c). No experiments, however, were run to assess the compatibility of the artificial skin model, as contrary to the original intent, preparation of the outer layer could not be done separately from the inner core. Hence, structural modifications to incorporate the cuff mechanism into the artificial skin model were deemed more difficult compared to the rubber cast model. The rubber cast model was therefore selected for further development.



**Figure 14:** (a) The artificial skin model made using polyurethane rubber. A qualitative compression touch test showed minimal deformation. (b) The artificial skin model made using silicone rubber. Deformation is much higher, implying softer texture. (c) Rubber cast models made using polyurethane (left) and silicone (right) successfully incorporated the cuff mechanism.

To optimize the characteristics of silicone rubber, Smooth-Sil 910 was substituted with the softer EcoFlex 0030, also from Smooth-On, Inc. Not only is EcoFlex 0030 better at texture mimicry, a compatible silicone dye, Sil-Pig Pink Flesh Tone, is available to enhance its appearance. A construction procedure was then meted out to produce a prototype (Figure 15a). Essentially, a plastic doll was modified and used as a mold to mimic the size and shape of an infant’s torso.

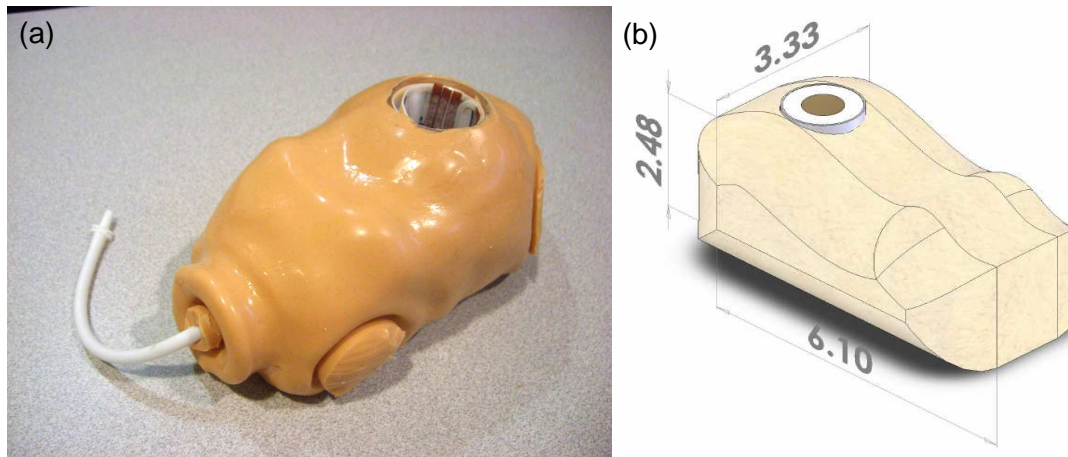

**Figure 15:** (a) The final prototype. Details of its construction are provided at Appendix B. (b) A technical drawing depicting the dimensions of the prototype. All measurements are in inches.

It was noted that the entire prototype weighed only 308 g, and its size was only about 35% of what was originally intended. However, with the fact that the density of EcoFlex 0030 is close to water (or human tissue) at about 1.07 g/cm<sup>3</sup>, it is likely that the weight and size of the model can be easily augmented to match those of an infant when its construction is translated into industrial processes such as injection molding. Moreover, further materials research can be done to identify a better and cheaper material. This is where the flexibility of the rubber cast model lies: its construction is adaptable to many materials.

Finalizing the external support design directs the project back to the issue of imperfect catheterization success of the cuff mechanism. As the original assumption was that excessive cuff pressure and blood clots could have impeded catheterization, an additional step was introduced to the usage instructions. By pumping water into the UV prior to catheterization, the cuff pressure can be assumed to be adequate if water successfully passes through it. Further pumping clears all blood clots and forms the blood reservoir. This additional step was tested against the NRP baby bottle model for catheterization success (Figure 16).

MODEL	SUCCESS OF CATHETERIZATION
Cuff Model	100%
NRP Baby Bottle Model	25%

**Figure 16:** Catheterization test results with an additional step in the usage procedure. Figures reflect the percentage of cord segments that could be successfully catheterized. (Sample size = 4)

## **Manufacturing Package**

Along with the recipe for constructing the cuff model, the manufacturing materials and methods, once identified, constitute the standard operating procedures – the first piece of information that needs to be included in the manufacturing package. Substantiating the standard operating procedures are detailed technical drawings. Additionally, testing results are required to prove the market niche of the product. Estimation of the production cost based on the raw materials, industrial equipment and labor, energy expenditure, intellectual property associated with original equipment manufacturers, materials research, and opportunity cost is also crucial. Lastly, the demand quantity in the current and future market must be determined. This is important as it directly correlates with product profitability and justifies the production cost.<sup>[11]</sup>

**Note:** With regards to the cuff model, no specialized machinery currently exists to assemble it, as it is a novel invention whose components are derived from products of various companies. However, it is possible to tap on and modify existing machines that perform similar functions to suit the needs of this project. Such a decision lies mainly on the manufacturer and will not be pursued in this semester until a suitable manufacturer is engaged.

### ***Standard Operating Procedures & Technical Drawings***

A user manual is crafted to describe how the prototype can be constructed and used based on the optimized procedures delineated above. Detailed safety information requires input from the manufacturer, and is hence left out in the current user manual. Technical drawings are provided in 2 and 3 dimensions. Both documents can be found at Appendices B and C respectively.

### ***Testing Results***

Based on the usage instructions defined in the user manual, surveys were conducted with pediatric residents at the Meriter Hospital to ascertain the advantages of the prototype over the NRP baby bottle model. The participants were asked to rate each model on a scale from 1 (strongly disagree) to 5 (strongly agree) on 3 primary aspects – cord stability, realistic experience, and biological safety – and provide comments on the functionality of each model.

Results revealed that the prototype was deemed more suitable for UVC training by the residents compared to the NRP model (Figure 17). In terms of cord stability, the prototype performed much better at preventing excessive movement of the cord. The residents readily observed that the prototype can be manipulated to fit various cord sizes, and the cuff pressure can be varied to accommodate various UV orientations within the cord. On the other hand, the NRP model is much more restricted in terms of its ability to adapt to various cord sizes and UV orientations, as its stabilization mechanism cannot be reversed once the nipple is cut.

The provision of an external support was the main reason why the prototype fared better than the NRP model in terms of realistic experience. The residents appreciated the mimicry of the infant's abdomen and found EcoFlex 0030 sufficiently representative of human tissue. It was noted that variability among the response was significantly larger than the others, but this could be explained by the fact that realistic experience is a more subjective issue. Nevertheless, the absence of such simulation in the NRP model rendered the prototype the more realistic training model.



Biological safety for both models was adequate as long as the user has undergone proper safety training. Being the currently accepted model, the NRP model must have fulfilled the safety standards of clinical training. Since the prototype did as well as, if not better than, the NRP model, it is likely that the prototype will fulfill the prevailing safety guidelines for it to be used as a training tool in the NRP.

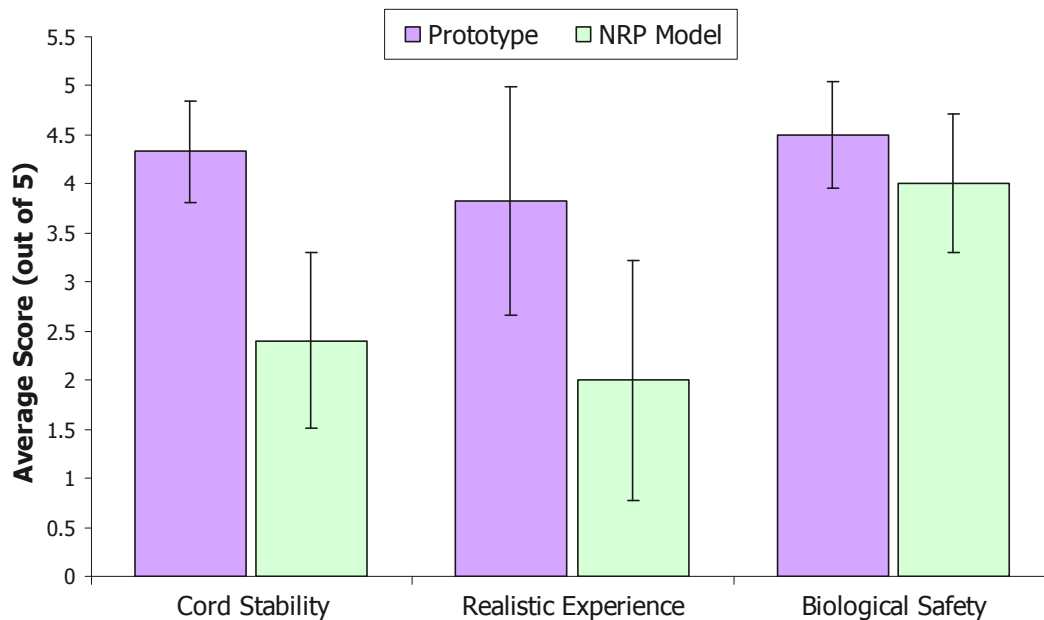

**Figure 17:** Survey results obtained from pediatric residents at the Meriter Hospital. (Sample size for prototype = 6; sample size for NRP model = 5)

### ***Production Cost Estimation***

Considering only raw materials, the current price of one prototype is about \$12.61 (Figure 18). The Medela 80-ml SpecialNeeds Feeder bottle was replaced with Medela 80-ml Breastmilk Freezing & Storage bottle to minimize the cost, since both of them are identically sized and have similar properties. It is estimated that in bulk production, the raw materials may be purchased at a 20% discount. Assuming that all other production costs can be summarized as a 6-fold mark-up from the cost of raw materials, the estimated retail price of the prototype is \$60.53. Not only is this within the target price range, it is significantly lower than prices of commercial products in the current market, considering the number of functionalities the prototype provides.

### ***Market Demand Estimation***

Annually, about 35,000 NRP courses are held across the world<sup>[12]</sup>. For every course, it is recommended by the NRP that 1 instructor is paired with 4 to 6 trainees. Assuming that each course involves only 1 instructor and that 2 prototypes on average would suffice per instructor, the annual market demand would be at least 70,000. This brings a raw income of \$4,236,960. Putting raw materials aside, there is \$3,530,800 to spare for other production expenditure, such as industrial equipment and labor. Given that the cost of an injection molding machine is between \$5,000 and \$200,000, the prototype is likely to be profitable in long term.

ITEM	RETAIL PRICE	USAGE COST
Medela 80-ml Breastmilk Freezing & Storage Bottle	\$14.00 / 12 pieces	\$1.17 / 1 piece
Philips M1870A Neonate 3 Blood Pressure Cuff	\$84.00 / 20 pieces	\$4.20 / 1 piece
Norton 3X Fine 150 Grit Premium Aluminum Oxide Sandpaper	\$5.00 / 9" by 11"	\$0.12 / 1440 mm <sup>2</sup>
Loctite All Plastics Super Glue with Activator*	\$5.39 / 1 set	\$0.27 / 1 use
Smooth-On EcoFlex 0030 Silicone Rubber	\$166.64 / 2 gallons	\$6.16 / 280 ml
Smooth-On Silc-Pig Pink Flesh Tone Silicone Dye	\$16.22 / 4 oz	\$0.69 / 5 ml
<b>TOTAL:</b>		<b>\$12.61</b>

Figure 18: Breakdown of cost estimation for one prototype.

### Future Work & Potential Difficulties

There are currently 3 potential manufacturers that the client has in mind: Laerdal, the American Academy of Pediatrics, and the S.T.A.B.L.E. program. Once a manufacturer is contacted, the preliminary agenda is to identify areas of ambiguity that the current test results are lacking. In addition, the prototype's compatibility with existing industrial processes will be assessed. One foreseeable difficulty is automated manufacturing of the cuff mechanism, as the current construction procedure heavily relies on manual labor. Also, negotiations with the target manufacturer and the original equipment manufacturers may have to be conducted to find out how best the manufacturing process can be expedited.

Pending the identification of a suitable manufacturer, the standard operating procedures will be optimized to improve the aesthetics of the prototype and user convenience. Clearance needs to be sought from the American Academy of Pediatrics to officially incorporate the model into the NRP. Further market research is also required to obtain better estimates for the target production quantity and cost. Specifically, the proportion of NRP instructors who are willing to replace the current training model with the prototype must be determined to have a better approximation of the future market demand.

### Credits

The team would like to thank Dr Julie Kessel and Professor Brenda Ogle for their guidance throughout the year, Professor Tim Osswald for his valuable advice on polymer selection and the manufacturing process, and Dr Elizabeth Goetz and Sharon Blohowiak who have selflessly lent their assistance in our umbilical cord experiments. The team also appreciates contributions from Angwei Law, Timothy Balgemann, and Padraic Casserly in the previous semester.

## References

1. Ronald A. Bergman, Adel K. Afifi & Paul M. Heidger, Jr. "Plate 13.261 Umbilical Cord". *Atlas of Microscopic Anatomy, Anatomy Atlases*.  
(Website: <http://www.anatomyatlases.org/MicroscopicAnatomy/Section13/Plate13261.shtml>)
2. "Umbilical Cord". *Wikipedia*.  
(Website: [http://en.wikipedia.org/wiki/Umbilical\\_cord](http://en.wikipedia.org/wiki/Umbilical_cord))
3. "Umbilical Artery". *Wikipedia*.  
(Website: [http://en.wikipedia.org/wiki/Umbilical\\_artery](http://en.wikipedia.org/wiki/Umbilical_artery))
4. "Umbilical Vein". *Wikipedia*.  
(Website: [http://en.wikipedia.org/wiki/Umbilical\\_vein](http://en.wikipedia.org/wiki/Umbilical_vein))
5. "Neonatal Resuscitation Program". *American Academy of Pediatrics*.  
(Website: <http://www.aap.org/nrp/nrpmain.html>)
6. "Insertion of Umbilical Vessel Catheters". *University of Iowa Health Care, 2006*.  
(Website: <http://www.uihealthcare.com/depts/med/pediatrics/iowanecanatologyhandbook/procedures/insertionumbilicalvessel.html>)
7. John Kattwinkel. "Textbook of Neonatal Resuscitation". *American Academy of Pediatrics, 5<sup>th</sup> Edition, 2006*.
8. William Ehman. "Umbilical Cord Model". *Canadian Family Physician, 2003*.  
(Website: <http://www.cfpc.ca/cfp/2003/Jan/vol49-jan-clinical-2.asp>)
9. "Baby Umbi". *Laerdal*.  
(Website: <http://www.laerdal.com.au/document.asp?subnodeid=32972403>)
10. Beth Weinhouse. "Sizing up your infant". *Your Baby Today, 2008*.  
(Website: <http://www.yourbabytoday.com/features/size/index.html>)
11. John Walker. "Design / Manufacturing Process". *Fourmilab Switzerland, 2008*.  
(Website: [http://www.fourmilab.ch/autofile/www/section2\\_83\\_13.html](http://www.fourmilab.ch/autofile/www/section2_83_13.html))
12. "NRP Celebrates 20<sup>th</sup> Anniversary". *NRP Instructor Update Newsletter, Fall/Winter 2007*. 16(2): 3.  
(Website: [http://www.aap.org/nrp/newsletter/2007\\_fallwinter.pdf](http://www.aap.org/nrp/newsletter/2007_fallwinter.pdf))

---

---

## **APPENDIX A: PRODUCT DESIGN SPECIFICATIONS**

**Project Title:** Umbilical Cord Model for Umbilical Vein Catheterization Training  
(Project Number: 22 / Code: umbilical)

### **Initial Problem Statement**

The American Academy of Pediatrics Neonatal Resuscitation Program (NRP) is required training for thousands of physicians and medical staff who attend the delivery of newborns. Placement of an intravenous catheter in the umbilical vein of the cord stump in a distressed newborn is one way to provide life-saving medication and is a skill that is essential to the NRP course. Hands-on training in the placement of an umbilical venous catheter has received increased attention and emphasis since the 2005 update of the NRP course. Currently, two models for hands-on training are available. Some companies make newborn models for CPR that also have artificial umbilical cords (eg. Laerdal). These models appear to inadequately mimic placement in a real cord and are very expensive. Alternatively, the American Academy of Pediatrics recommends using sections of an umbilical cord obtained after delivery. The cord section is placed in a glass baby bottle with part of the nipple cut off so the cord extends about 1/2 an inch from the top of the nipple. While this model has the advantage of using a real cord, the cord is secured poorly and thus does not adequately mimic placement in a newborn. The goal of this project would be to create an inexpensive and disposable model that would be a vast improvement over the “baby bottle” model for teaching and could be patented and marketed to the over 25,000 individuals in the US who teach NRP.

During the first semester of this project, the umbilical team designed two working models, the “cord-in-gel” and “sphygmomanometer”. Both models had good tensile test assessments and limited but promising side-by-side comparisons of catheterization success. Additional design work is needed for both models before consideration of patent and production. The superior model needs to be identified, and the materials and construction process need to be refined for bulk manufacturing. The mold for the “cord-in-gel” model needs additional design work with alterations to mimic the course of the umbilical vein in the body and modifications to ensure correct placement of the cord in the gel and exit of the cord end to a reservoir. The “sphygmomanometer” model was created from a blood pressure cuff and purchased materials. This model needs to be designed from appropriate materials with a built-in “cuff”. The design for the support system for both models will need to be altered accordingly. In addition, part of the design goals will include work with human cords to determine if cord orientation, storage (eg. freezing), or fixation affect the model. Ultimately, we will have physicians test the models side by side to gather data for the possible patenting of this product through WARF, including success of catheterization, biosafety, and infection control data.

### **Revised Problem Statement**

The superior model has been identified as the “sphygmomanometer” (or cuff) model. The design focus now lies on the creation of an external support that incorporates the cuff model and mimics the infant’s abdomen. As umbilical vessels themselves will be used to simulate the systemic blood vessels upon the umbilical cord’s entry beyond the umbilicus, the course of the umbilical vein in the abdomen needs not be mimicked. Manufacturability of the entire model must be considered as a design constraint. At the end of the semester, a manufacturing package that encompasses all pertinent information required for a manufacturer’s assessment should be prepared. This includes testing results as mentioned in the initial problem statement.

## Client Requirements

- Fresh human umbilical cords are to be used within 1 to 2 days before significant postnatal deterioration begins and renders the cords unsuitable for handling.
- The umbilical cord should be well stabilized and be able to withstand the mechanical forces involved during catheterization training.
- At least 2 cm of the umbilical cord should extrude from the surface of the model, while 3 cm of it should be embedded within the model to simulate the systemic blood vessels.
- A variety of cord sizes must be accommodated.
- A blood reservoir should be included to contain blood-mimicking solution that can be drawn to verify catheter depth during catheterization training.
- The external support of the stabilizing mechanism should mimic the infant's abdomen in terms of dimensions and weight, and its texture must resemble human soft tissue and be opaque.
- Materials should be disposable to ensure biosafety, but should at least be durable for the period of usage.
- The final product must be user-friendly and require minimal or no preparatory work by the user.
- The model should perform better than existing models and must be manufacturable in a standard production line.

## Design Requirements (for External Support)

### *1. Physical & Operational Characteristics:*

- a. **Performance Requirements:** The external support must mimic the infant's abdomen in terms of dimensions, weight and texture, and incorporate the cuff model without compromising the stability of the umbilical cord.
- b. **Safety:** Materials used in the entire model must be disposable since physical contact with human tissues is anticipated. Additionally, the model must not contain sharp edges, or any mechanisms that permit skin contact with human tissue during usage. Expected device failures must not endanger the user.
- c. **Accuracy & Reliability:** The dimensions and weight of the external support should be within 10% from those of an average healthy infant. Texture mimicry will be assessed using compliance testing, but the acceptable accuracy has yet to be determined. Methods and materials employed to construct the external support must optimize reproducibility to reduce variance among the products at both design and manufacturing stages.
- d. **Life in Service:** Each usage should last for at least 2 hours between opening of the packaging and disposal of the product.
- e. **Shelf Life:** At least 2 years of storage is expected since NRP training presumably occurs at least 45 times a year per participating hospital.
- f. **Operating Environment:** Normal clinical or laboratory environment.

- g. **Ergonomics:** The model should require minimal or no preparation on the user's part. During usage, the user must be sufficiently "convinced" by the abdominal mimicry, and the catheter should be inserted at least 5 cm into the umbilical vein to be considered successful.
- h. **Size:** Assuming that the "abdomen" is roughly rectangular, the external support should be around 30 cm by 15 cm by 5 cm, and contain a cylindrical hole of 1.75" in diameter to incorporate the cuff model.
- i. **Weight:** Between 1 kg to 2 kg, considering the average weight of a newborn is 3.4 kg and the abdomen is approximately 30% of the body weight.
- j. **Materials:** One fresh human umbilical cord per use, but may be sectioned such that 2 to 4 products share the same cord. Soft elastomers or other low-density polymers will be considered to mimic the texture of the infant's abdomen.
- k. **Aesthetics, Appearance & Finish:** The model must resemble an infant's abdomen primarily in terms of texture. Color will be of secondary concern.

### *2. Production Characteristics:*

- a. **Quantity:** About 70,000 units per year.
- b. **Target Product Cost:** Raw materials should cost less than \$15 for 1 product. Target retail cost is less than \$90.

### *3. Miscellaneous:*

- a. **Standards & Specifications:** The design and construction of the model must comply with manufacturing standards and the NRP guidelines.
- b. **Customers:** Any clinical institution that is involved in the NRP umbilical vein catheterization training.
- c. **Patient-Related Concerns:** The donor of the umbilical cords must remain anonymous to the designers and users of the model.
- d. **Competition:** The recommended baby bottle model currently used in NRP. Commercial products include "Baby Umbi" from Laerdal.

## **APPENDIX B: USER MANUAL**























**APPENDIX C: TECHNICAL DRAWINGS**

A 2-dimensional isometric drawing of the prototype (all measurements are in inches):

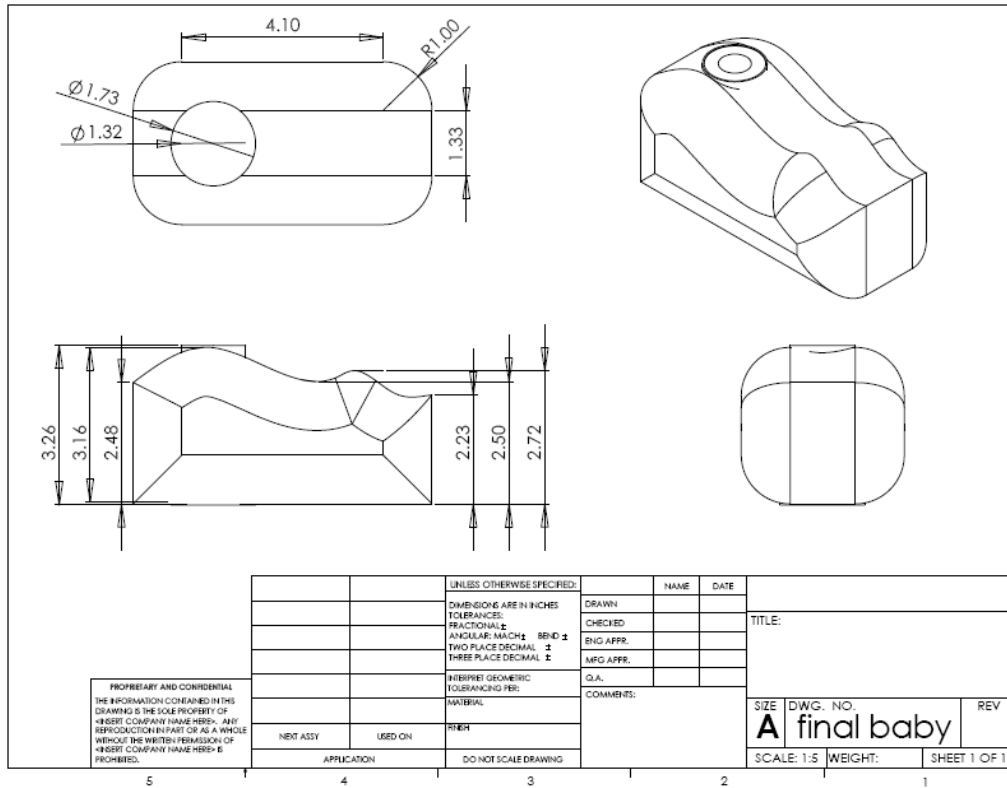

A 3-dimensional representation of the prototype (all measurements are in inches):

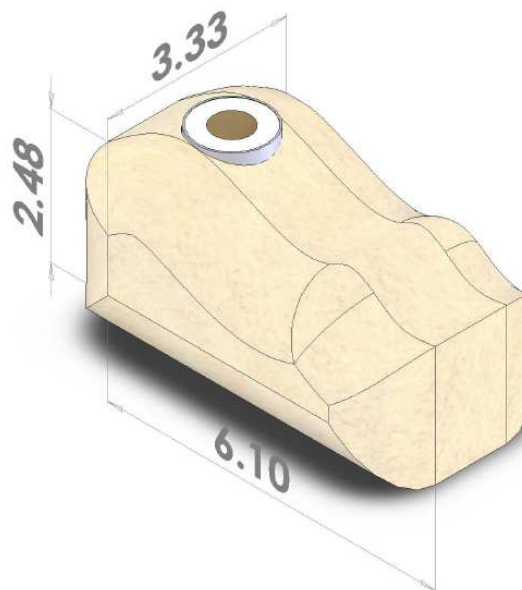

**APPENDIX D: PROJECT EXPENDITURE**

SOURCE	ITEM	QUANTITY	TOTAL PRICE (USD)
Wal-Mart	Knox Gelatin	12 packs	12.00
	<b>Subtotal (with tax):</b>		<b>12.00</b>
Goodwill Industries International	Cabbage Patch Baby Doll	1	3.15
	<b>Subtotal (with tax):</b>		<b>3.15</b>
Home Depot	Paint Tray	2	1.05
	Sponges	6 blocks	5.70
	Plaster of Paris	2 packets	12.66
	Spray Adhesive	1	9.45
	Foam Paint Brush	2	1.67
	Gloss	1	4.90
<b>Subtotal (with tax):</b>		<b>35.43</b>	
Walgreens	Bucket	2	6.94
	<b>Subtotal (with tax):</b>		<b>6.94</b>
Toys 'R Us	Berenguer Baby Doll	1	20.03
	<b>Subtotal (with tax):</b>		<b>20.03</b>
University Book Store	Ring Binder	1	2.37
	Transparent Holders	7	1.48
	<b>Subtotal (with tax):</b>		<b>3.85</b>
College Library Printing Services	Poster	1	35.00
	<b>Subtotal (with tax):</b>		<b>35.00</b>
<b>TOTAL:</b>			<b>116.40</b>

**APPENDIX E: TIME CONTRIBUTIONS OF INDIVIDUAL MEMBERS**

<b>WEEK #</b>	<b>ANN SAGSTETTER</b>	<b>SONGYU NG</b>	<b>MEGAN BRITSON</b>	<b>FAN WU</b>
0	15	18.5	12.5	12
1	7.75	8.75	6.75	6.75
2	8.75	9.5	6.25	6.25
3	6.5	9.5	4	4
4	9.5	8	7.5	4.5
5	8.25	14.5	1.75	4.5
6	11.25	4	6.75	1.25
7	5.75	5	4.25	4.25
8	14.5	12.5	7	7
9	4.25	4	3.5	3.5
10	10	14	9	9
11	10	12	9	9.5
<b>TOTAL:</b>	<b>111.5</b>	<b>120.25</b>	<b>78.25</b>	<b>72.5</b>

**Note:** All figures listed are in hours.