

Bronchoalveolar Lavage Trap

Ali Johnson, Kim Kamer, Elise Larson and Laura Zeitler

March 11, 2009

Table of Contents

ABSTRACT	3
BACKGROUND	3
BRONCHOALVEOLAR LAVAGE.....	3
PROBLEM STATEMENT.....	4
CURRENT SOLUTIONS.....	5
ERGONOMICS.....	5
DESIGN CONSIDERATIONS	6
FIXED LONG DISTANCE	6
BALL AND SOCKET FRAME	7
BALL AND CAGE VALVE.....	7
DESIGN EVALUATION	8
FUTURE WORK	9
REFERENCES.....	10
APPENDIX A: PRODUCT DESIGN SPECIFICATIONS	11

Abstract

Bronchoalveolar lavage is a procedure that involves taking a lung effluent sample by injecting saline solution into the lungs, retrieving it, and depositing it into a specimen trap. If the specimen trap is freely hanging in space, however, manipulation of the bronchoscope can lead to inversion of the trap and subsequent loss of sample to the vacuum line. In order to address this issue, we designed three new preliminary trap solutions to eliminate the risk of losing the effluent sample. The first involves designing a frame for the trap in order to fix it to a universal site in the exam room; the second uses the force of gravity keep the trap vertical with a ball and socket frame. The final design attaches a ball and cage valve between the trap and the tubing to the vacuum source to form a seal between the trap and suction whenever the trap is turned. Though these options all have potential, upon evaluation, we determined that our best design to be the ball and cage valve. Future work includes determining the specifications and materials for fabrication, constructing our prototype, and extensively testing and modifying our prototype.

Background

Bronchoalveolar Lavage

Bronchoalveolar lavage is a procedure performed on immuno-suppressed patients to collect an aqueous lung tissue sample for laboratory analysis (Prakash *et al.* 2007). Because this analysis often leads to a workable diagnosis, preserving the collected effluent sample safely and consistently is critical to an affected patient's health and comfort (Lee 2004).

The process of bronchoalveolar lavage involves the skilled use of specialized equipment. A flexible bronchoscope, suction tubing, vacuum source, and sterile collection trap work in unison to obtain the effluent sample (Dugdale and Medoff 2008). The flexible bronchoscope involves a long and thin tube with a lighted end to allow the doctor to view the airway (WebMD 2007).

First, the patient is either anesthetized locally or generally, depending on age and condition. Children are usually put under general anesthesia. The flexible bronchoscope is inserted into the trachea via the nose or mouth and maneuvered into one lobe of the lung,



Figure 1. A pulmonary specialist maneuvers flexible bronchoscope within patient.

Image courtesy of Department of Respiratory Care

<http://www.uihealthcare.com>

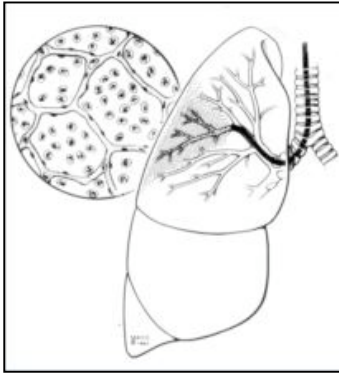

Figure 2. View of flexible bronchoscope wedged into bronchiole. Close-up shows cells that will be washed into effluent solution.

Image courtesy of "The Art of Bronchoscopy"

<http://www.bronchoscopy.org>

where the tip of the scope is then tightly wedged into a bronchiole. A camera located at the tip of the scope allows the specialist to visually investigate the area (NHLBI 2008).

Once the scope is positioned firmly in the bronchiole, the bronchoscope is connected to the vacuum source with tubing that is 1.2 to 2.2 mm in diameter. Approximately 100 mL of 0.9% saline solution is injected through the scope into the bronchiole, washing epithelial cells from the pulmonary wall into the saline solution (Oulu University 2000). These cells represent the contents of millions of alveoli. The aqueous sample is then suctioned out of the bronchiole, and deposited into a specimen trap. Excess sample is suctioned through the trap and into a waste container (Prakash *et al.* 2007).

After the sample is collected, it is sent to a laboratory for analysis, and subjected to several tests. The results of these analyses can then be used to diagnose malignancies, alveolar hemorrhage, or infection in the lungs of the patient (American Registry of Pathology 2007).

Problem Statement

In the current procedural setup, the specimen trap is free hanging and unstable (Figure 3). Manipulation of the bronchoscope and surrounding movement can displace the trap resulting in loss of sample to the vacuum line. When the trap is inverted, the vacuum quickly pulls the sample solution to the trash trap where it is irretrievable. Losing the sample can cost up to \$4,000 because the procedure may need to be redone. This is inconvenient for all involved, but especially for the patient, as there is special risk associated with a procedure performed under

general anesthesia.

An additional aspect of the problem with the current trap is the method of transportation to the lab. The sample could ideally be transported in the specimen trap as displayed in Figure 4, however it does not meet the general



Figure 4. The tubing on specimen trap that connects to the scope can be attached to the vacuum connection to enclose the system.



Figure 3. The specimen trap is free hanging causing unwanted movement of the trap upon scope movement.

laboratory transportation requirements. These requirements include a tightly sealed container that could be sent through hospital pneumatic tube systems without concern of sample loss.

Current Solutions

The current solutions to avoid loss of sample are effective but inconvenient. The first solution involves crudely taping the specimen trap to the bronchoscope. This solution, however, prevents the doctor from having a secure grip on the scope and limits ability and accuracy. The second solution requires additional personnel to hold the specimen trap steady and upright throughout the procedure. However effective, this method is undesirable and expensive.

For transportation within the UW Hospital, the current solution is to transfer the sample from the trap to a sterile urine cup. This transfer carries the additional risk of sample loss due to spilling. It is also wasteful and costly since both the trap and urine cup are disposed after use. Although not used by the UW Hospital, Covidien currently sells specimen traps with an extra secure cap to ensure ease of transport (Covidien 2009).

Ergonomics

Ergonomics is an important factor to this project because medical personnel use the device during the lavage procedure. The device must allow the procedure to be done efficiently, safely and reliably. Performing the procedure as smoothly as possible will ensure that the patient is subject to the least amount of discomfort. It is also important to avoid unnecessary repeated procedures due to expense and inconvenience. The current solution to prevent sample loss involves taping the trap to the bronchoscope or having additional staff hold the trap upright. Taping the trap to the scope prevents the doctor from obtaining a comfortable grip on the scope and having an additional person to hold the trap makes the procedure more expensive and the environment overcrowded. While redesigning the trapping system, we want to make sure that the new solution does not interfere with the procedure or change it in a negative way. The medical community has been performing bronchoalveolar lavage with little change for years (Soffer 1994) and a drastic change is unlikely to be accepted. Therefore, our improved design should not change the way the procedure is performed. By preventing the possibility of sample loss when inversion occurs, bronchoalveolar lavage will run more smoothly and be more ergonomic.

Design Considerations

Since current bronchoalveolar lavage traps are free hanging and easily shifted out of place, the sample is sometimes accidentally lost to the vacuum source. The client would like a cost effective trap design to allow manipulation of the bronchoscope without losing the sample. Although the initial prototype and testing may prove to cost up to \$100, the final product should cost less than \$10 to be mass-produced or the design is unlikely to be accepted by the medical community. The trap device should ideally be made of plastic in order to avoid problems with latex allergies and cells adhering to the glass surfaces. It must hold at least 35 mL of sample, be able to withstand more than 40 kPa vacuum pressure, and function without disrupting the current procedure (Appendix A).

Upon researching solutions to the transportation problem, a medical supplier (Covidien 2009), not used by the UW Hospital, was found to have already solved the issue by providing an additional secure cap with the specimen trap. Therefore, since this problem has a readily available solution, we decided to focus on developing a better trap set up. We devised three preliminary design options:

Fixed Long Distance

The fixed long distance design uses a frame to attach the lavage trap close to the vacuum source, extending the length of the tube to about 3 to 4 m to reach the bronchoscope (Figure 5). By fixing the trap in a sturdy location and preventing motion in any direction, the chance of losing the sample is completely eliminated. The frame that attaches the trap in place would have adjustments to allow for any sized trap to fit and be held in place. The advantages of this design are its simplicity and low cost. However, it is not universal between exam rooms since there is no common location where it could be attached because hospitals and exam rooms vary. It is also problematic that the doctor would not be able to see the trap during the procedure and therefore is unable to know when it has been filled.

There would be some time delay as well between the suction of lung effluent and the filling of the trap due to tube length between the scope and the trap.

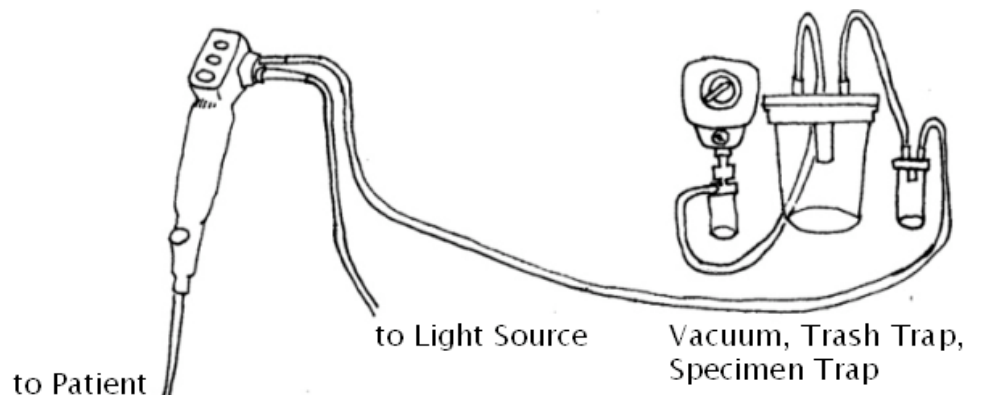

Figure 5. The fixed long distance design involves fixing the specimen trap (80 mL) away from the scope with 4 m of tubing.

Ball and Socket Frame

The ball and socket frame design uses gravity to prevent the trap from being inverted and losing the sample. A fixed frame that includes a ball and socket joint is attached to a sturdy location on the bronchoscope and extends several inches away from the scope (Figure 6). The ball and socket would allow free rotation in almost all directions. If the manipulation of the scope displaced the trap at any angle, the freely moving ball would rotate around in its socket until the trap was once again perpendicular to the ground. Advantages to this design include that it is reusable and universal. The frame could be connected to any bronchoscope because all scopes include a port connecting to the light source that is strong enough to support our frame. Some flaws in the design include its possible inability to realign without sample loss with quick scope movement. The frame is also a bulky attachment that may get in the way of the doctor's manipulations of the scope, perhaps interfering with the procedure.

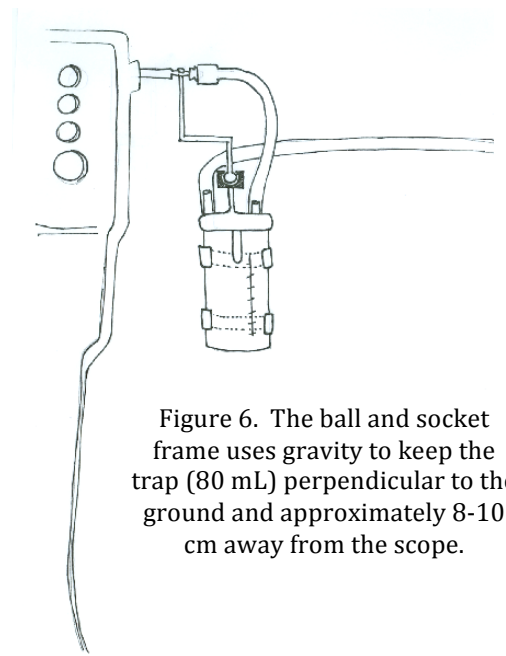

Figure 6. The ball and socket frame uses gravity to keep the trap (80 mL) perpendicular to the ground and approximately 8-10 cm away from the scope.

Ball and Cage Valve

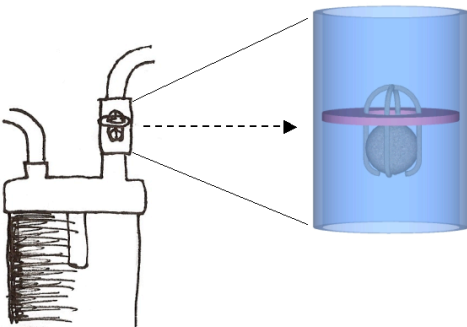

Figure 7. The ball and cage valve with a diameter of approximately 2 cm and a length of 4 cm is an attachment that connects between the trap (80 mL) and vacuum tubing.
Valve constructed in Google Sketch

The ball and cage valve incorporates an internal valve mechanism to prevent fluid flow out of the trap. The assembly includes a sphere enclosed in a cage threaded through a softer, washer-shaped disk. The disk acts as a stopper and seal and is located inside a plastic cylinder. This system is then connected externally between the trap and vacuum tubing (Figure 7). The valve acts as a preventative mechanism to stop the flow of the sample in the trap to the vacuum source on the wall. Once the trap is displaced at the desired angle, the ball will travel along the cage while being pulled up by the vacuum until it is lodged into the soft disk, creating an airtight seal (Figure 8). If the trap is once again returned to its proper configuration perpendicular to the ground, the ball will fall back into place at the bottom of the cage and allow air to pass around it. An advantage to this design is that it can be used in any setting since it attaches

externally to the original trap lid and vacuum tubing. Because the attachment is small, not cumbersome, and presents little change to the current procedure, the design is likely to be accepted among practitioners. The prototype cost for this design may be slightly higher than the others and it may be more difficult to calculate the needed details for full functionality; however, the completed prototype will be an innovative solution.

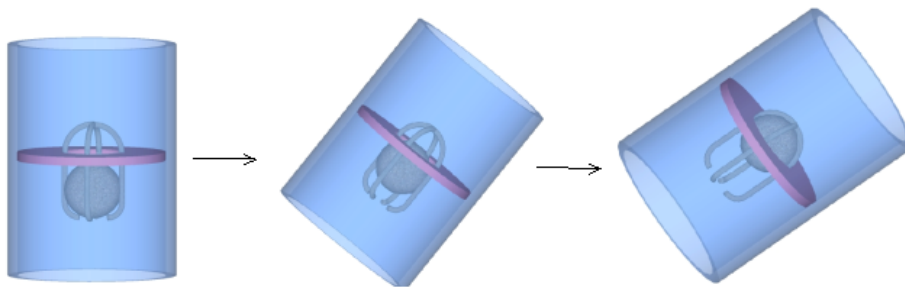

Figure 8. As the trap tips, the sphere starts to travel along the cage and is eventually pulled up into place by the vacuum creating a seal.

Valve constructed in Google Sketch.

Design Evaluation

The fixed long distance design, the ball and socket frame and the ball in cage valve were all evaluated on a scale of one to ten and weighted on a variety of design criteria (Table 1). The most important criteria were given more weight in the matrix, which included the mass production cost, the friendliness to the user, the feasibility of building the prototype, and the dependability of the device. These aspects were determined to be the most important design characteristics because they are most important in terms of patient safety and effective functionality of the final product. The mass production cost was considered one of the most important aspects because the problem fixed by our prototype is an annoyance, but not a major problem to the medical community. If our design is expensive—even more than a few extra dollars per procedure—it is unlikely to be used. Prototype cost, universality, acceptability, and bulkiness were determined to be less important, as these characteristics do not directly inhibit effective use of the design in the field, and were therefore weighted less heavily in our analysis. Based on the results, the ball and cage valve is the most favorable and therefore is the design we will pursue.

Weight	Design Aspects	Fixed Long Distance	Ball and Socket Frame	Ball in Cage Valve
0.05	Prototype Cost	8	4	6
0.2	Mass Production Cost	8	9	5
0.05	Universality	3	8	10
0.2	User Friendly	3	8	10
0.2	Feasibility	10	7	8
0.05	Acceptability among MDs	3	3	10
0.2	Dependability	8	9	10
0.05	Bulkiness	8	4	10
1	TOTAL	6.9	7.6	8.4

Table 1. Design matrix that displays our evaluation on a scale of one to ten and weighted on a variety of design criteria for all three design concepts.

Future Work

The first thing we need to do is determine material and manufacturing specifications. Details including the weight of the ball, length of the cage and diameter of the stopper hole need to be established through calculations and testing. We currently are in the process of acquiring information from the Polymer Engineering Center at the University of Wisconsin-Madison to determine the kind of plastics and methods that can be used to manufacture a prototype. After finalizing details and ordering materials, an initial prototype must be constructed and be extensively tested using vacuum pressure and water to simulate the effluent. The testing will take place in the Biomedical Engineering Department at the UW Hospital and will be used to determine the limitations of the design and will be evaluated accordingly. Our design will then be modified to fit the results.

While we chose the design that best matched our needs as laid out in our design matrix, there are a few key limitations that we are aware of with the ball and cage design we are pursuing. First of all, it may prove difficult to find a way to make sure that no sample is lost before the ball makes a seal when tipped. However, we expect the sample loss in this situation to be minimal because as the sample is pushed into the cage, we expect it to also help push the ball upward, aiding the seal formation. In addition, we may not be able to find a ball weight that is heavy enough to avoid vacuum suction under normal conditions, but light enough to fall back down after the trap is corrected after a seal has been formed. If we are not able to accomplish this factor in our design, the doctor or medical personnel involved in the procedure could simply pinch the tubing to reduce vacuum suction instantaneously, resulting in the ball falling back down.

References

- American Registry of Pathology. "Bronchoalveolar Lavage". Medscape Today. 2007. Viewed on February 9, 2009. http://www.medscape.com/viewarticle/549031_3
- Covidien. Argyle Lukens Specimen Containers. 2009. Viewed on February 14, 2009. <http://www.kendallcriticalcare.com/criticalcare/pageBuilder.aspx?contentID=103991&webPageID=0&topicID=70216&breadcrumbs=0:108244,81044:0,67443:0#FAQs>
- Dugdale, D.C., Medoff, B. "Bronchoscopy." Medline Plus. 2008. Viewed on Feb 1, 2009. <http://www.nlm.nih.gov/medlineplus/ency/article/003857.htm>
- Lee, Augustine S. 2004. "Bronchoalveolar Lavage." American Thoracic Society. Viewed on March 1, 2009. <http://www.thoracic.org/>
- NHLBI, National Heart Lung and Blood Institute. "What To Expect During Bronchoscopy" Bronchoscopy. 2008. Viewed on March 6, 2009 http://www.nhlbi.nih.gov/health/dci/Diseases/bron/bron_during.html
- Oulu University Library. "Type I and III procollagen propeptides in sarcoidosis, fibrosing alveolitis and asbestos-related lung diseases." 2000. Viewed on January 24, 2009. <http://herkules.oulu.fi/isbn9514253728/html/x207.html>.
- Prakash, Udaya, Mehta, Atul, Shepherd Wes. "The Art of Bronchoscopy." Bronchoscopy International: Art of Bronchoscopy, an Electronic On-Line Multimedia Slide Presentation. 2007. http://www.bronchoscopy.org/ppt-art/AB-2A/AB-2a_files/frame.htm
- Soffer, Alfred. "The Pulmonary Clinical Consultant". Pharmaceutical Division. 1994. VHS.
- WebMD. "Bronchoscopy." 2007. Viewed on February 9, 2009. <http://www.webmd.com/a-to-z-guides/bronchoscopy-16978>.

Appendix A: Product Design Specifications

Function:

The purpose of the bronchoalveolar lavage trap is to collect a fluid sample from a bronchiole using a lighted bronchoscope attached to a suction unit. The trap should be stable, rigid, cost-effective, able to hold at least 35 mL of sample and must capture and prevent the sample from being pulled into the trash trap. It should also be secure when closed and able to withstand transportation to fit the criteria of medical specimen receiving laboratories.

Client Requirements:

- Cost Efficient
- Plastic – avoid latex
- Gradations of volume
- Must hold at least 35 mL
- Cannot be attached to bronchoscope handle

Design Requirements:

- 1) Physical and Operational Characteristics
 - a) *Performance requirements* – Must be able to contain sample despite bronchoscope movement.
 - b) *Safety* – Must be sealed tight and a durable container
 - c) *Accuracy and Reliability* – Should be able to repeat procedure with little or no deviation.
 - d) *Life in Service* – One-time use, must be able to withstand transportation and contain sample for at least 6 hours.
 - e) *Shelf Life* – Able to withstand a basic medical storage environment.
 - f) *Operating Environment* – Must be able to withstand 300 mm Hg.
 - g) *Ergonomics* – Should not interfere with regular procedure.
 - h) *Size* – Must hold at least 35 mL of fluid.
 - i) *Weight* – Should be as light as possible.
 - j) *Materials* – Cost-efficient, no latex or glass, plastics preferred.
 - k) *Aesthetics* – Should be transparent.
- 2) Production Characteristics
 - a) *Quantity* – One, but should be designed with the intent of mass production in the future.
 - b) *Target Product Cost* – Under \$10
- 3) Miscellaneous
 - a) *Standards and Specifications* – Should not lose the sample.
 - b) *Customer* – Medical Community
 - c) *Patient-related concerns* – Do not include latex to avoid problems with latex allergies.
 - d) *Competition* – Current traps lose sample easily.