

HEART & BREATH SOUNDS AMPLIFIER FINAL REPORT

BME 201
Department of Biomedical Engineering
University of Wisconsin-Madison
May 4, 2011

Drew Birrenkott, Team Leader
Bradley Wendorff, Communicator
Jared Ness, BWIG
Caleb Durante, BSAC

Client
Scott Springman, M.D.
UW School of Medicine and Public Health
Department of Anesthesiology

Advisor
Willis Tompkins, Ph.D.
University of Wisconsin-Madison
Department of Biomedical Engineering

Table of Contents

Abstract.....	3
Background and Other Methods.....	4
Client Requirements.....	5
Data Collection & Interpretation.....	6
Initial Design.....	8
Design Options.....	10
Design Matrices.....	12
Current Design.....	15
Testing.....	18
Future Work.....	19
Budget.....	20
Safety and Ethics.....	21
References.....	22
Appendices	
Appendix A: Product Design Specifications.....	23
Appendix B: Electronic Circuit Diagram.....	25
Appendix C: Executive Summary.....	26

Abstract

The standard acoustic stethoscope has become the hallmark of the medical profession. In wide use for over a hundred years, it is not a device that is easily replaced by new technology. In recent years electronic stethoscopes have entered the market for prices roughly two times as much as standard stethoscopes. Our project is to design an electronic stethoscope that increases the functionality of the standard stethoscope three fold while maintaining the fidelity of standard acoustic stethoscope. The three areas of increased functionality are: converting the acoustic sound waves from the stethoscope to a filterable, amplifiable electronic signal, increasing the length of the stethoscope so the heartbeat can be heard from further away, and creating both headphone and speaker listening capabilities. As a first step, we conducted data collection to determine the appropriate amplification and bandwidth. After the data collection we created a plan for a design consisting of three main components: initial sound pick-up, conversion of acoustic sound to an electric signal, and amplification, filtering and audio of the signal. We then considered different design alternatives through design matrices and determined that the optimal microphone type is a condenser microphone, the best microphone location is inside the tubing, and the top power source is battery. From this preliminary design work and design matrices we proceeded to design and construct the electronic stethoscope. The final design consists of a the normal stethoscope head running into a microphone which converts the acoustic signal to an electronic one. The signal enters a circuit containing an amplifier and filter for the whole system as well as specific amplifiers for a output to headphones and an output to speakers. The design is housed in a polycarbonate box with two switches and two potentiometers for user adjustment. The future work for the project includes increasing amplification of the prototype while avoiding excess background noise and making the switch from analog to digital.

Background & Other Methods

The medical stethoscope was first invented in 1816 by French physician René Théophile Hyacinthe Laënnec in order to hear the sounds of the heart and other organs in the chest (Bause 2010). As the process of listening to the sounds of the organs in the chest became widely practiced, it became known as auscultation (Sterne 2010). But, the use of the stethoscope was not widely practiced initially; however, it provided many advantages over direct ear to chest auscultation including no interference from the rest of the face and the ability to listen to areas where face to body contact was not appropriate or possible (Sterne 2010).

The basic acoustic stethoscope has evolved over time, but is still based on a fairly simple design. The stethoscope operates using a diaphragm that is placed on the chest which vibrates in and out with the vibrations of the body (Rappaport and Sprague 1941). The sounds created by the diaphragm then travel into the bell of the stethoscope and pass through a long rubber tube (Rappaport and Sprague 1941). The tube serves as a filter to guarantee that only sounds from the body are transmitted to the ears (Rappaport and Sprague 1941). The final step is the passage of the sound through binaural ear pieces for the listener to hear (Rappaport and Sprague 1941) (Figure 1).

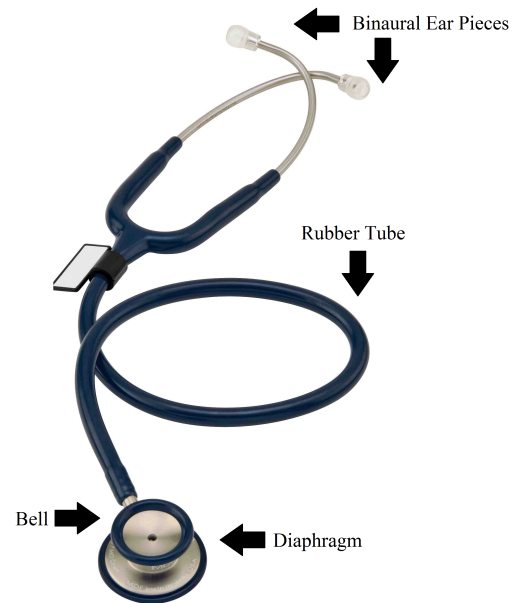

Figure 1: Diagram of a standard acoustic stethoscope including labels for different stethoscope elements. (Alibaba.com 2011)



Figure 2: 3M Littman 3100 Electronic Stethoscope (Medisave 2011).

The acoustic stethoscope is still the most widely used type of stethoscope, but as technology has increased, different variations of stethoscope have entered the market including electronic stethoscopes. One of the more popular electronic stethoscopes on the market is the 3M Littman 3100 Electronic Stethoscope (3M Corporation 2011) (Figure 2). The Littman 3100 Electronic Stethoscope maintains all of the functionality of a standard stethoscope but is also able to amplify heart sounds 24x and reduce the effects of ambient noise on the sounds by up to 85% (3M Corporation 2011). The largest downfall of the Littman 3100 Electronic Stethoscope is the cost, its listed MSRP is \$342.47 while that of an acoustic medical grade stethoscope ranges from \$75.00 to \$95.00 (Welch-Allyn Medical Supply Store 2011). For this design project we are looking to emulate the functionality of the Littman 3200 Electronic Stethoscope in its ability to amplify sounds, but we want to extend beyond its functionality in the length of the stethoscope and its ability to be heard on multiple audio components. To do this we plan on using the components of the standard acoustic stethoscope and using a microphone to create an

electric signal.

Client Requirements

The client has specified three components of the stethoscope's functionality to be enhanced as well as a few design specifications that must be met.

The first aspect of the functionality is the conversion of the acoustic sound signal into an electronic signal that is both filterable and amplifiable. This is a critical improvement in the operating room setting that our client normally works in because operating rooms have a large amount of background noise. The ability to increase the volume of the stethoscope will thus guarantee that the client is always hearing the heart and breath sounds clearly.

The second aspect of functionality to be addressed is the stethoscope length. This design aspect comes from the fact that the client is an anesthesiologist and often has to adjust medication dosages during surgery. The stethoscope cannot reach the machine where dosages are adjusted. This requires the client to stop listening to the heart and breath sounds of the patient while adjusting medication. Increasing the length of the stethoscope should easily alleviate this problem.

The final aspect to be addressed is the audio output of the device. The client would like to see the stethoscope be able to transmit sounds to both headphones and speakers. This would increase the functionality because heart and breath sounds could be heard individually in the operating room, and could be heard by a group in an educational setting such as when a medical educator is training medical students.

Along with these three aspects of functionality the client has a few design constraints including that the device must incorporate the existing stethoscope design and preserve its diagnostic capabilities, it must be transportable from operating room to operating room, it cannot create an electrical interference on the head of the stethoscope which might interrupt the function of an electrical device implanted into a patient, and the budget must be within \$100 to \$300.

Data Collection & Interpretation

The primary goal of the design is to create an electronic version of the stethoscope with added functionality over the current standard. With this goal in mind, there are several important considerations to be made in creating a working prototype. Primarily, the design must be created to deal with the excess noise levels associated with recording a very faint noise and amplifying it to ranges easy audible to the human ear. These high frequency background noises can pollute the recorded signal rendering it useless to the client. Signal filtering will therefore be necessary. Additionally, excess amplification can cause clipping or distortion of the recorded signal rendering it equally useless to the client. Thus, to create an electronic stethoscope that matches the fidelity of a current acoustic stethoscope the prototype will need to utilize appropriate signal filtering schemes as well as an overall amplification gain that balances the need for an audible signal with the need to preserve the subtle diagnostic aspects embedded into a patient's heart and breath sounds.

Data Collection

With the goal of determining which parts of the frequency spectrum are active in heart and breath sounds, our team deemed it necessary to collect several samples of heart and breath sounds for analysis. An existing stethoscope was modified as shown (Figure 3) to digitally capture sample recordings of heart and breath sounds. The rubber tube was cut from the stethoscope ear pieces and a small actively powered condenser microphone was attached to the top of the tube, protected in foam, and fastened with duct tape. The heart was measured at variable gain levels from different loci on the chest and breath sounds were recorded from a location above the sternum and also below the right shoulder blade on a subject's back. Each location was recorded at a total of four different gain levels (25%, 50%, 75%, 100%) This was done to determine how much amplification would be required in the prototype as well as to determine how much gain was harmful to the signal.

Signal Processing

In order to determine which frequencies made up the sound of a heartbeat, a sample recording of the heart was imported into MATLAB for digital signal processing. Through the use of the Discrete Fast-Fourier-Transform (FFT), we were able to obtain a plot of the frequency spectrum vs. amplitude for our sample recording. Figure 4 shows the FFT plot. Initial research indicated



Figure 3: Recording Apparatus used to obtain heart and breath sounds samples.

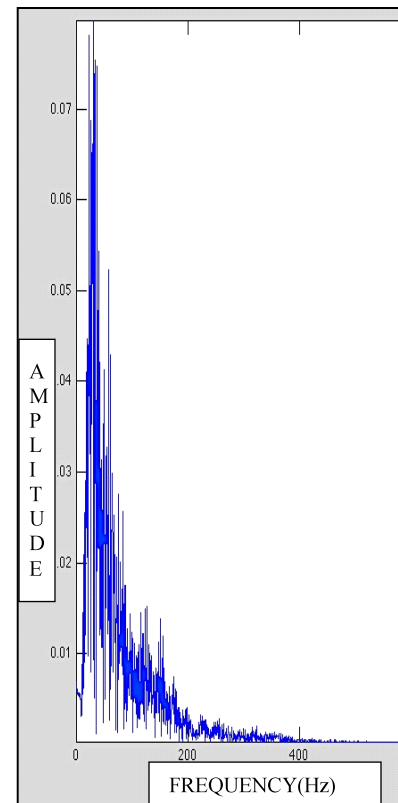

Figure 4: Single-sided amplitude spectrum of sample recording

that the sound of the heart beating resided around 300Hz and below (Jin et al. 2009), and this information is confirmed by our data.

Filter Modeling

While listening to the given sample (recorded at 100% gain), the heartbeat can be easily discerned. However, the high gain in recording resulted in excess noise dominating the signal. A low-pass filter is necessary to remove the unwanted hiss from the recording. Our team has decided to construct an active filter circuit to filter the signal instead of providing our prototype with DSP capabilities. Using the data we collected from the FFT on our signal, we modeled a low-pass filter appropriate for our design. Figure 5 shows the low-pass filter model that we created. It is an active, low-pass, third order, Butterworth filter with a cutoff frequency of 300Hz.

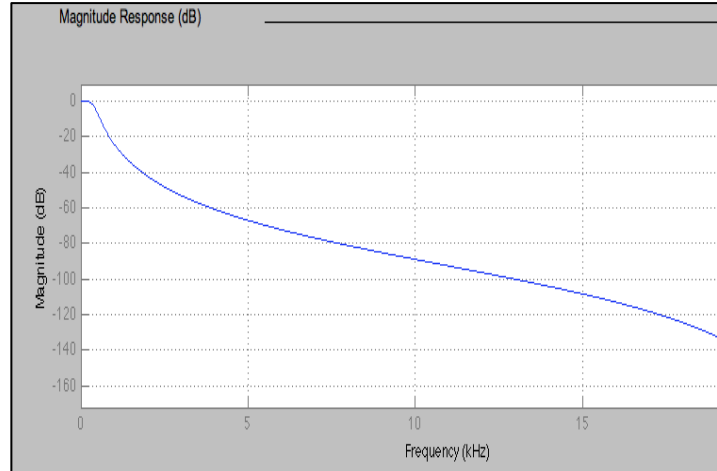

Figure 5: Low-Pass digital filter model (MATLAB)

Additional Filtering Considerations

Because device must not filter out any sounds that are diagnostically relevant, it was necessary to determine the frequency components of irregular heartbeats. A literature search was conducted and multiple heartbeat irregularities were considered. It was further determined that a corner frequency of 800Hz would encompass the vast majority of irregular sounds, with an ample amount of headroom. Figure 6 shows the FFT plot of a heartbeat with a murmur. Compared to figure 4, there are additional frequency components in the signal around 200-500 Hz.

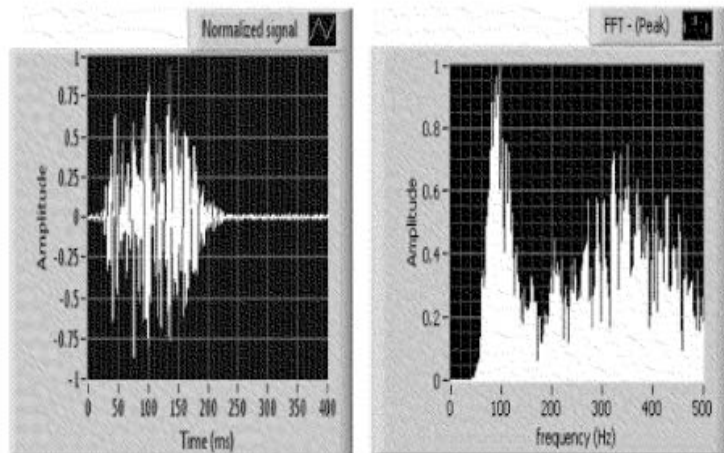

Figure 6: (Left) normalized heartbeat with murmur signal. (Right) single-sided amplitude frequency spectrum of murmur recording, note components at 300hz and above.

Initial Design

Using the data collected on heart and breath sounds, we laid out plans to create a device that will maintain the design concepts of an acoustic stethoscope and convert the acoustic signal to an electronic signal which will allow us to increase functionality as planned. The major components

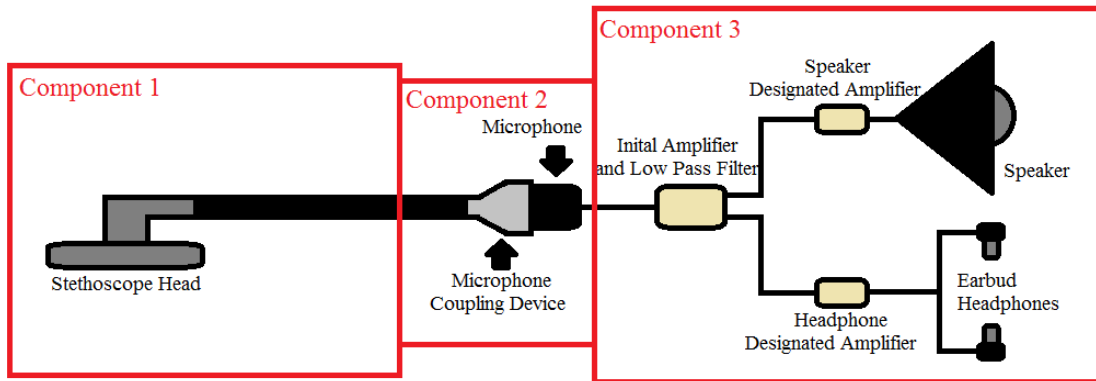

Figure 7: General block setup for current design showing three major design components: initial sound pick-up, conversion of acoustic sound to electrical signal, and amplification, filtration, and audio sound of the signal

of the design can be divided into three main sections: the initial sound pick-up, the conversion of acoustic sound to an electric signal, and the amplification, filtration and audio sound of the signal (Figure 7).

The first component of the design focuses on maintaining as much of the standard stethoscope design as possible. In the design the head of the stethoscope is kept and potentially a length of the rubber tubing will be kept because they help to maintain the fidelity of the original acoustic stethoscope design and keep the design simple as possible. The head of the stethoscope is crucial because it has the unsurpassed noninvasive ability to retrieve heartbeat and breath signals. These signals then lead into the rubber tubing, another important design, due to its ability to filter out excess noise not wanted by the user (Rappaport and Sprague 1941). The tubing will then lead off the chest away from the body to component two.

Component two is the conversion of the acoustic sound to an electronic signal. This conversion will either occur away from the stethoscope head or directly in it. The design will require a small microphone with high quality pick-ups so even a quiet heartbeat can be clearly picked up and sent into the amplifier.

Regardless of how the microphone functions there is still a need for additional filtering and amplification which is the purpose of the third component of the design. In order to create this filtering and amplification, the signal will travel from the microphone into a box containing an analogue filtering circuit as well as an amplifier. The decision to use analogue as opposed to digital was made for ease of design, and cost effectiveness. The filter design to be used is a low-pass Butterworth filter which is based on the digital filter applied using MATLAB. The Butterworth filter (Figure 8) is an active filter meaning it has gain, is able to filter out signals,

and can create a clear filtered signal due to rapid decay of unwanted frequencies and a longer pass-band (Figure 5). With a higher order Butterworth filter, the decay of unwanted frequencies and the length of the pass-band increase (Storr 2011). We chose to use a second order low-pass filter, in order to make the signal of the heartbeat as clear as possible. The equations for both gain and corner frequency of the Butterworth filter are found in figure 9. In addition to the filter the second part of the third component is amplifying the signal so that the heartbeat and breath can be heard in both speakers and ear phones.

The final step in the third component is conversion of the electronic signal to actual audio. Because there are two audio options, headphones and speakers, a switch can be selected for either the earphones or the external speaker. Both have independent amplifiers contained in the circuit box and have controls used to adjust volumes for the listener to hear.

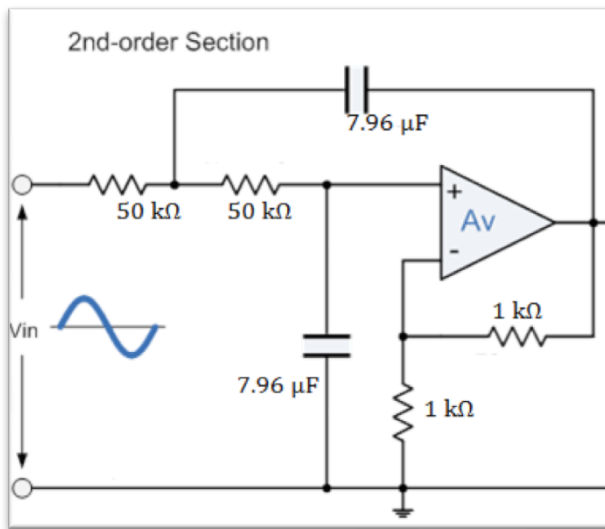

Figure 8: 2nd Order Butterworth filter circuit (Storr 2011).

$$A_v = 1 + \frac{R_2}{R_1}$$

$$f_c = \frac{1}{2\pi \sqrt{R_3 R_4 C_1 C_2}}$$

Figure 9: Circuit equations for cutoff frequency and open loop gain used to calculate resistance in Butterworth circuit.

Design Options

Along with the general outline of the overall design, three main design components were heavily weighed. These design options reduced to three major decisions, microphone type, power source, and microphone location in the device. The general set up for the device will consist of parts taken from a basic acoustic stethoscope, a microphone that may be housed in two different places in the device, a circuit enclosed in a circuit box that is expected to be no larger than a 15cm cube, an external speaker, and a pair of headphones.

Microphone Type

Advantages and disadvantages of three different types of microphones were analyzed and compared. The three types of microphones that were considered were: a condenser microphone, a dynamic microphone, and a piezo microphone. Condenser microphones (Figure 10), otherwise known as capacitor microphones, work by means of a capacitor, which converts acoustical energy into electrical energy (MediaCollege 2011). They require an external power source, which is reason for their higher output than that of dynamic microphones, which do not require external power. Condenser microphones are very sensitive to sound, which is why they are not commonly used for high-volume recording. In order to function, condenser microphones rely on a capacitor, which has two plates with a voltage between them. The front plate, otherwise known as the diaphragm, is made of a very light material so that when sound waves come into contact with it, the distance between the plates change and a current is produced. The closer the plates are, the greater the current produced, corresponding to the intensity of sound waves.

The second microphone considered is the dynamic microphone (Figure 11). They are very common in settings that require a microphone that can handle a high input volume. They do not contain

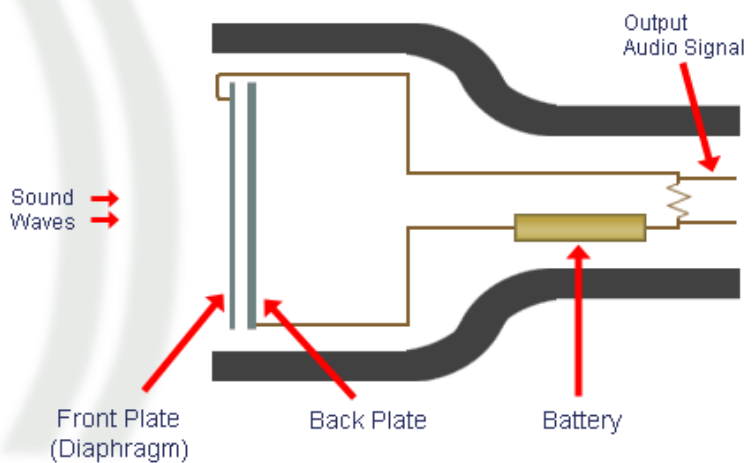

Figure 10: Cross-Sectional view of condenser microphone

Cross-Section of Dynamic Microphone

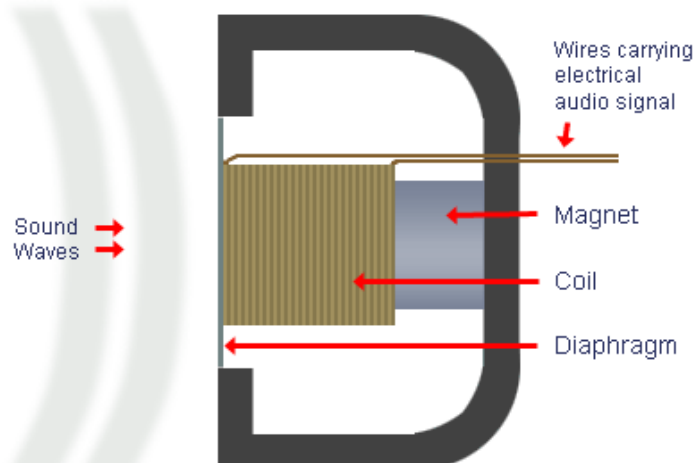

Figure 11: Cross-sectional view of dynamic microphone element

an internal amplifier, and also are able to operate without a power source, unlike the condenser microphone. Instead of a capacitor plate, dynamic microphones rely on a magnet and coil to create a current. The coil is attached to a diaphragm, which will vibrate as it is impacted by sound waves. The vibrations cause the coil to move in relation to the magnet, which creates a current. This phenomenon is known as the electromagnet principle.

The final microphone consideration is the piezo microphone. The piezo microphone functions by means of piezoelectricity, which is the ability of a material to produce a voltage when pressure is applied to it. These microphones are often used to amplify sound from acoustic instruments, such as a guitar. Rather than using a diaphragm as illustrated by the condenser and dynamic microphones, the piezo microphone utilizes materials such as crystal or certain ceramics to produce an electric current.

Microphone Location

Within the device, two possible locations for the microphone were considered. The first design would place the microphone inside the tubing, some distance away from the diaphragm of the stethoscope (Figure 7). Acoustic stethoscopes sound the way they do, because of the mechanical filtering done by the tube, prior to the sound reaching the doctor's ears. This low-pass filter is responsible for the sound that doctors have become accustomed to. Placing the microphone in this location would require a coupling of some sort to act as the medium between the tubing and circuit box, which could be made on a rapid prototyping machine. This design allows for preservation of the mechanical filtering, yielding a sound consistent with that of a standard mechanical stethoscope.

The second location considered involved placing the microphone directly inside the diaphragm at the end of the tube. This could improve the aesthetics and stability of the stethoscope, but as a compromise, the mechanical filtering done by the tube would be lost. It would require some creative manipulation of the stethoscope head in order to fit the microphone inside.

Power Source

Because this is an electronic device, some external power will be required to power it. The two power sources considered were battery operated and an external power cord, which would be plugged into a standard wall outlet. It is estimated that a 9-volt battery will be sufficient enough to power the device for an extended period of time. 9-volt batteries are used to power devices that show moderate drain levels, such as a clock radio or baby monitor. The battery would be housed within the circuit box, and would supply power to both the circuit and condenser microphone, should that be the type selected.

The other option is to use an external power source that plugs into a wall outlet. This would definitely limit range of motion with the device, as it would be constrained to the length of the cord. On the positive side though, there would never be the need to replace the power source. The cord would extend out of the circuit box, and have some type of Velcro strap to secure it when it is not in use to increase ease of transportation.

Design Matrices

Based on our assessment of the problem, we determined three key areas in which design decisions needed to be made: microphone type, power source, and microphone location.

		Microphone Type		
Factors	Weight	Rating (1-10)		
		Condenser Mic	Dynamic Mic	Piezo Mic
Cost	0.10	4	5	2
Sensitivity/Fidelity	0.40	9	4	3
Size	0.25	7	6	4
Simplicity/Circuit Requirements	0.25	4	8	8
TOTAL	1.00	6.75	5.60	4.40

Figure 12: microphone type matrix

Figure 12 contains the design matrix for the microphone type to be used in the device. Sensitivity/Fidelity was rated highest for this matrix, because in order to have a usable stethoscope, the sound that it produces must be as accurate as possible in terms of replicating a mechanical stethoscope. The sensitivity of the condenser microphone ranked highest out of the three, because of its excellent transient response, coverage of a wide frequency band, and high output volume. The condenser microphone is commonly used with quieter sounds, because the external power allows for the signal to be amplified upon recognition. Size and simplicity were both rated second. Should the microphone be too large, portability of the device would be compromised, which our client defined as a necessity. The condenser microphone that is currently being implemented is 10.0mm in diameter, by 5.0mm in depth, plenty small to maintain portability of the device. The simplicity of circuit requirements was given the same weighting as size, because in order to have a functioning electronic stethoscope, the microphone must be correctly integrated into the device. The condenser microphone received a lower score than the other two microphones, because of the external power source requirement that's associated with that type of microphone. Finally, cost was weighted the lowest in this design matrix. The specified budget of \$100-\$300 makes cost less of a factor, and without the proper fitting microphone for the device, diagnostic information may be compromised. Piezo microphones are the most expensive of the three. The numbers show that the condenser microphone is the best option for the device.

Power Source			
Factors	Weight	Rating (1-10)	
		Batteries	External Power
Life	0.30	2	9
Life-Cycle Cost	0.15	3	4
Portability	0.35	9	2
Client Preference	0.20	7	5
TOTAL	1.00	5.60	5.00

Figure 13: Power source design matrix

Figure 13 contains the design matrix for how the device will be powered. The client emphasized portability of the device, so that it can be carried from operating room to operating room with ease. Given that, portability was ranked highest to ensure the best power source option was chosen. Batteries were rated highly in this factor, because a battery-powered device can be transported much easier than one that requires a wall outlet. External power would limit range of motion, and would also introduce another cord in the operating room, creating a potential tripping hazard. The life of the power sources was weighted second highest, because a constant need to replace batteries would not only cause an annoyance to the user, but could also be problematic should the device lose power during a critical situation. Batteries were rated very low, due to the fact that they do run out of power over time, and will have to be replaced. External power is of course incredibly reliable, and will only need to be replaced should the cord fail. Client preference was weighted third highest, as the client explicitly noted that he would prefer batteries to an external power. Finally, life-cycle cost was weighted lowest, because pricing for either option is not all that expensive. As for the batteries, rechargeable batteries have been considered, which could greatly reduce life-cycle cost. After taking all factors into consideration, it was determined that batteries would be the best power source to fit the design specifications.

Microphone Location			
Factors	Weight	Rating (1-10)	
		Inside Tubing	Inside Diaphragm
Fidelity	0.35	7	4
Stability/Portability	0.10	4	7
Aesthetics	0.05	5	8
Multifunctionality	0.10	8	2
Safety	0.40	8	2
TOTAL	1.00	7.10	3.50

Figure 14: Microphone location design matrix

Figure 14 contains the design matrix for microphone location in the device. The two designs being considered were a device that housed the microphone inside the diaphragm of the stethoscope, or at the end of the tube connected to the diaphragm. Safety of the device was most heavily weighted, because it is ultimately counterproductive to introduce a new hazardous variable into the operating room that may harm the patient. It was noted by our client that a design in which the microphone would come in direct, or very close contact with the patient, could potentially be harmful to patients who have electronic devices such as a pacemaker. Given that, it was decided that the microphone should be housed in the tubing to minimize that risk. The second most important factor in this design matrix involves maintaining the fidelity of the acquired signal. The design for this device is not intended to re-invent the traditional stethoscope sound, but to preserve the sound that doctors have become accustomed to, and increase its volume. The tube attached to the diaphragm acts as a low-pass filter, which is reason for why stethoscopes sound the way they do. Placing the microphone inside the diaphragm would result in a loss of the mechanical filter, and potentially a completely different sound in comparison to traditional stethoscopes. Ratings defined in safety and fidelity alone made it evident that the microphone should be housed in the tubing for the best possible design.

Current Design

The current prototype follows the same original layout and features as outlined in figure 7 with a few slight alterations to improve the functionality of the device. Following the functional diagram in figure 7, the heartbeat signal originates at the bell of the stethoscope and the vibrations of the thin diaphragm send sound waves up the rubber tube which acts as a mechanical



Figure 15: Stethoscope bell with microphone coupling mated with rubber tube

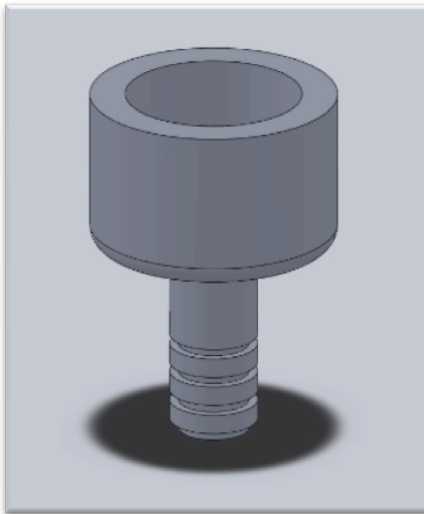

Figure 16: Drawing of microphone tube coupling in SolidWorks. Ridged edges are inserted into rubber tubing and microphone sits in the large cup on top.

low pass filter which helps to imitate the sound of an ordinary stethoscope (Figure 15). Approximately 0.3 meters from the head the sound waves are captured by the electret condenser microphone housed in a plastic coupling specifically designed in SolidWorks and printed on the 3-D printer. A number of coupling devices were designed so that it would pressure fit into the tubing and couple with the microphone and specific head attachments slipping or sound escaping pickup (Figure 16). From here, the sound waves are converted into the electronic signal. The original design calls for rubber tubing to carry the wires from the junction box to the microphone. However, through testing, it was determined that the rubber tubing simply conducted the sounds emitted by the speaker down the tube and back to the microphone which resulted in an undesired feedback loop. Sacrificing durability for functionality, the rubber tubing was removed from the prototype and the wires run unprotected into the junction box and breadboard. (Left, Figure 17).

Following the circuit diagram (Appendix B), the signal enters the schematic from the left side. First the signal passes through a DC blocking capacitor and is subjected to a non-inverting voltage follower, second-order low pass filter, and finally an active gain stage providing amplification of 10x. Research was done to determine the appropriate corner frequency for the filter and 800Hz was selected to provide headroom for the heart and

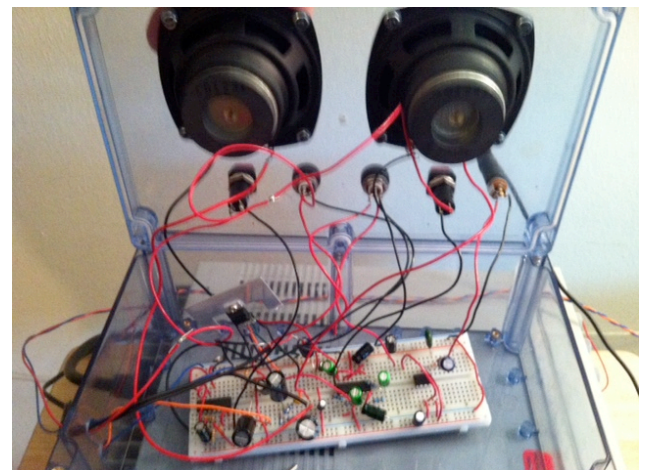

Figure 17: View of open junction box, breadboard, and rear view of controls panel.

breath sounds but also for some higher frequency noises caused by heart murmurs (Altrabsheh 2011). After the buffering, filtering and gain stages, the signal is routed to the desired audio outputs. Before entering either the headphone driving circuit or the speaker driving circuit, the signal is subjected to voltage dampening by a potentiometer, which acts as a volume control (Figure 18). Depending on the settings of the front switches as well as the presence of headphones in the headphone jack, the signal is outputted from the headphones, the speakers, or both. The speakers were taken out of the Altec Lansing VS2620 computer speaker assembly and are rated for 5 watts at 4 ohms.



Figure 18: Front view of control panel. From left to right: headphone jack, Speaker power switch, headphone volume, speaker volume, On/Off.



(C) HWTech, 2008

Figure 19: LM386N operational amplifier to power the headphones

The area of greatest technical design was in the selection of amplifiers for the headphones and speakers. The LM386 (Figure 19) was chosen for the headphones based on the recommended application information from its manufacturer STMicroelectronics (ST 2011). As configured, by itself, the LM386 offers a nominal gain of 20 which, when

coupled with a potentiometer, provides adequate volume resolution for a pair of headphones. The TDA2003 (Figure 20) was chosen to drive the speakers because of its high power rating and simple voltage/current supply requirements. STMicroelectronics lists car stereo amplification in its recommended applications and can be configured for very high levels of gain (ST 2011). Currently, the amplifier is set to provide a gain of 100, which can be increased or decreased by altering resistor and capacitor values within its circuit.



Figure 20: TDA2003 Power Amplifier used to power the external speakers

In order to amplify a quiet signal such as the human heartbeat, high-levels of amplification are necessary. However, with this comes the necessity for high levels of power not readily furnished by the use of batteries. It is for this reason as well as semester time constraints that the design does not have an independent power source such as batteries, and must therefore be powered using a variable supply. Currently the device uses 12V DC and pulls approximately 100mA at peak speaker output. The circuit as a whole utilizes a collection of single supply operational amplifiers all operating at a supply voltage of 12 Volts and a virtual ground of 6 volts, which is created by a series of buffered voltage dividers at the very beginning of the circuit (Appendix B).

The completed circuit containing all filters and amplifiers is housed in a clear polycarbonate box that holds the speakers all of the controls for the user including an on/off switch, an on/off switch for the speakers, a headphone jack, and a potentiometer for volume control for both the headphones and speakers (Figure 18). The lid of the box is fastened to the body of the box using six screws. The side of the box contains a hole for the feed coming from the microphone to enter.

In practice, the device can be operated by a teaching physician in the following way:

- Device is powered on
- Headphones are plugged into the device and placed on the physician's ears
- While adjusting the headphones volume potentiometer, the physician places the stethoscope bell over the patient's heart and listens for a clear heartbeat rhythm.
- Once the physician is satisfied by the sound coming through the headphones, he or she can power on the external speakers to reproduce said sound for students or other physicians present, adjusting the speaker volume potentiometer appropriately.
- The physician may return to headphone-only operation at any point during operation simply by pressing the speaker power switch.
- Once the device is no longer in use, it is powered off.

Testing

To insure that our final design would meet the criteria that we expected it to, we needed to test each aspect of our circuit and compare those results to what was calculated beforehand. In order to complete this, four aspects of our circuit needed to be investigated.

The start of our circuit, a series of voltage dividers and followers, was first checked to make sure that a 12V source would be broken down to 3V and 6V respectively. This was proven to be true by the use of a signal generator feeding into the circuit and being displayed at the output by an oscilloscope.

Our circuit then moved on into the filtering and amplification component. Here once again a signal was sent into the circuit through the signal generator, at incrementing frequencies starting at 10Hz and moving up to 1kHz, and outputted into the oscilloscope. This was done, to check that our Sallen-Key filters were working true and cutting off correctly at the initially proposed 800Hz. The gain was also checked and found through the amplification of the sine wave 10 times that of the input.

The last part of the circuit involves amplification for either a speaker or headphones. We tested the functionality for both, first by plugging in an iPod into the circuit and secondly by actually hooking the microphone up to the stethoscope to hear our own heartbeats. This testing was able to show us that the drive of the speakers and the volume of the headphones were loud enough to be heard audibly and clearly.

Future Work

While the current design is functional, and meets the client's baseline requirements, the team acknowledges that there is work that can be done to improve upon current aspects of the device.

- Because the acquired signal from the heart and lungs are such minute sounds, an optimal amplification and filtering needs to be determined in order to reduce the current signal to noise ratio. As one would expect, the signal cannot be amplified without amplifying background noise, which can be attributed to a variety of sources such as electrical appliances, radios, and electromagnetic waves. One possible improvement that could be made to the current design would involve wire wrapping. A second way to improve this ratio is to incorporate notch filtering. Notch filtering would allow for very specific frequencies to be filtered out. In order to accomplish this, the team would need to determine what frequencies the noise is most prevalent in, and then construct a filter that eliminates them.
- The circuit is expected to be diagnostically sound on patients with heartbeat irregularities, as it has been designed to pass frequencies up to 800Hz . The team plans to test the device on patients with already known heartbeat irregularities to ensure that diagnostic information is preserved in a clinical setting, as it has already been tested in the lab by means of an oscilloscope.
- Currently, the device is being powered by a power supply, rather than batteries as requested by the client. In order to make the device fully functional powered by batteries, the team needs to determine the type of batteries to use, and how long it will last under normal operating use. Normal use at this stage draws approximately 100mA , but with the anticipated goal of increasing the output sound, that value will certainly rise, requiring more power.
- When the bread boarded circuit is up to acceptable standards as approved by the client, a printed circuit board will be made. This will also help to eliminate background noise, and will increase portability of the device. Finally, a printed circuit will eliminate potential for disconnection of leads. With the decreased size of the circuit, the team also has plans of shrinking the size of the circuit box by means of printing a SolidWorks drawing on a rapid prototype machine.
- When all filter and amplification details are nearly perfected, yielding a signal with high fidelity and high volume, the team has plans of converting from an analog circuit to digital on Lab View, implementing a microcontroller with Bluetooth capabilities. Though this idea hasn't fully been explored, it is anticipated that the Bluetooth capabilities will allow for wireless listening, bearing that there isn't too much interference with noise emitted by operating room devices.

Budget

The overall cost of the project was \$225.90 which was within the range of the \$200-\$300 range given by the client (Figure 21). The budget includes all electronic and physical components required for the project except the microphone couplers which were created for free on a Biomedical Engineering Department 3-D printer, and some various circuit components obtained from the Biomedical Engineering Department Bioinstrumentation Lab.

Date	Item	Company	Quan.	Unit Cost	Total Cost	Order Tot.
3/31/2011	Microphone (680 ohm)	Mousser Electronics	4	\$2.06	\$8.22	\$8.22
3/31/2011	Potentiometer (10K Ohm, 1W)	Digi-Key Corporation	2	\$11.07	\$23.36	\$23.36
3/31/2011	Foam Adhesive-Back	McMaster-Carr	1	\$6.44	\$6.44	\$15.70
	Foam Adhesive-Back		1	\$7.38	\$7.38	
	9 Volt Battery Leads		4	\$0.47	\$1.88	
4/2/2011	Computer Speakers	Newegg.com	1	\$29.99	\$29.99	\$29.99
4/7/2011	9V Batteries (4 Pack)	Walgreens	1	\$14.24	\$14.24	\$14.24
4/8/2011	Audio Amplifier (12W)	Digi-Key Corporation	5	\$2.35	\$11.75	\$13.82
4/9/2011	Resistors (1 ohm)	Mousser Electronics	5	\$0.14	\$0.70	\$50.74
	Capacitor (2.2uf)		5	\$0.24	\$1.20	
	Capacitor (0.1uf)		5	\$0.08	\$0.40	
	Resistor (2.2 ohm)		5	\$0.33	\$1.65	
	Resistor (220 ohm)		5	\$0.13	\$0.65	
	Resistor (39 ohm)		5	\$0.05	\$0.25	
	Resistor (430 ohm)		5	\$0.13	\$0.65	
	Capacitor (1000uf)		3	\$1.78	\$5.34	
	Capacitor (5.0uf)		5	\$2.50	\$12.50	
	Capacitor (10uf)		10	\$0.22	\$2.20	
	Resistor (28 ohm)		10	\$0.09	\$0.90	
	Capacitor (0.3uf)		3	\$0.92	\$2.76	
	Capacitor (470uf)		3	\$1.27	\$3.81	
	Capacitor (100uf)		5	\$0.68	\$3.40	
	Capacitor (10uf)		5	\$0.53	\$2.65	
	Capacitor (0.1uf)		5	\$0.30	\$1.50	
	Resistor (200 ohm)		10	\$0.25	\$2.50	
Resistors (16 ohm)	10	\$0.09	\$0.90			
Capacitor (15uf)	2	\$3.39	\$6.78			
4/14/2011	Rubber Tubing (10mm OD, 3m)	McMaster-Carr	1	\$7.30	\$7.30	\$18.19
	M4 Stainless Steel Screws		1	\$8.13	\$8.13	
	C Battery Housing		1	\$2.76	\$2.76	
4/20/2011	SPST Switch	Digi-Key Corporation	2	\$2.83	\$5.65	\$5.65
4/20/2011	Circuit Housing Box	McMaster-Carr	1	\$40.08	\$40.08	\$40.08
4/27/2011	Circuit Box Hardware	True Value	1	\$5.91	\$5.91	\$5.91
Overall Total						\$225.90

Figure 21: Overall budget for the construction of the current design prototype.

Safety & Ethics

Given that this device will be used in a hospital setting, safety and ethical issues are of utmost importance. Testing of the device needs to be conducted thoroughly to ensure that no diagnostic information is lost while using this device as opposed to a regular stethoscope. Any doctor should be able to identify any irregularity in a patient's heartbeat or respiratory sound with the same clarity that a normal stethoscope provides.

To minimize safety issues during regular use, several variables were considered both in the best interest of patient and user. As noted in the design matrix for microphone location (Figure 14), the microphone was integrated into the device in such a way that it had minimal chance of interfering with other medical devices implanted in the body. All other electrical components are housed in a circuit box, eliminating the potential for electric shock during use. The circuit box is designed with rounded edges and corners.

References

- 3M. 2011. "3M Littman Electronic Stethoscope Model 3200." http://www.shop3m.com/3m-littmann-electronic-stethoscope-model-3200.html?WT.mc_ev=clickthrough&WT.mc_id=shop3m-AtoZ-Littmann-Stethoscopes (accessed March 2, 2011).
- Alibaba.com. 2011. "MDF 77704 Stainless Steel Dual Head Stethoscope." http://www.alibaba.com/product-gs/346985222/MDF_77704_STAINLESS_STEEL_DUAL_HEAD.html. (accessed March 8, 2011).
- Altrabsheh, B. 2011. Measurement and classification of heart and lung sounds by using Labview for educational use. *Journal of Medical Engineering and Technology* 35: 340--349.
- Bause, G. 2010. Laennec's 1819 Stethoscope. *Anesthesiology* 1(112): 18.
- Dynamic microphones.
<http://www.mediacollege.com/audio/microphones/dynamic.html> (Retrieved March 8, 2011).
- Condenser microphones.
<http://www.mediacollege.com/audio/microphones/dynamic.html> (Retrieved March 8, 2011).
- Jin, F., Satter, F., Goh, D.Y.T. 2009. A filter bank-based source extraction algorithm for heart sound removal in respiratory sounds. *Computers in Biology and Medicine* 39: 768-777.
- Medisave. 2011. "3M Littman Model 3100." <http://www.medisave.net/3m-littmann-model-3100-electronic-3100-stethoscope-black-3100bk.html> (accessed March 8, 2011).
- Rappaport, M., Sprague, H., 1941. Physiologic and physical laws that govern auscultation and their clinical application: the acoustic stethoscope and the electrical amplifying stethoscope and stethograph. *American Heart Journal* 3(21): 257-318.
- Repas, R. Sensor sense: Piezoelectric force sensors, February 7, 2008. <http://machinedesign.com/article/sensor-sense-piezoelectric-force-sensors-0207> (Retrieved March 8, 2011).
- Sterne, J. 1990. Early Chapters in the Stethoscope's Evolution. *Journal of the American Medical Association* 21(264): 2817-2820.
- ST Microelectronics. www.st.com (accessed April 2011)
- Welch Allyn Medical Supply Store. "Welch Allyn, Medical Supply Store and Medical Equipment." (accessed on March 8, 2011).

Appendix A: Product Design Specifications

Heart and Breath Sound Amplifier Preliminary Product Design Specifications Drew Birrenkott, Caleb Durante, Brad Wendorff, Jared Ness

Function: The function of the device being designed is to increase the functionality of the standard medical acoustic stethoscope in three ways while maintaining the diagnostic capabilities of the original stethoscope design. The three areas of functionality are to be increased are: converting the acoustic sound waves from the stethoscope to a filterable electronic signal, increase the length of the stethoscope so the heartbeat can be heard from further away, and create dual listening capabilities so the sounds from the stethoscope can be heard both in standard headphones as well as a speaker.

Client Requirements:

1. Ability to hear sounds clearly with both headphones and speakers.
2. Device must be able to be transported from one operating room to another.
3. Device cannot introduce harmful electrical interference onto the body of the patient.
4. Amplification process must preserve all diagnostic information that a normal stethoscope can provide.
5. Device needs to stay within a budget of \$100-\$300.

Design Requirements:

1. Physical and Operational Characteristics

- a. *Performance Requirements:* The device can be expected to be used multiple times daily and must perform to medical standards each time. Amplification must be to a minimum of 60 dB and the frequency must not exceed 300 Hz.
- b. *Safety:* The device cannot introduce any harmful electrical interference to the patient or anyone operating the device. This is especially important for electrical devices that have been implanted such as pacemakers. Furthermore, the device must be approved for use by the proper committees and hospital staff members.
- c. *Accuracy and Reliability:* The device needs to provide heart and sound amplification of the same or better diagnostic quality as a medical stethoscope.
- d. *Life in Service:* There is no specific life in service characteristic for this device, but it likely needs to be reliably used for multiple years.
- e. *Shelf Life:* The device will likely be battery operated and the only shelf life concern is battery replacement every three to four months.
- f. *Operating Environment:* The heart and breath sound amplifier will be used in a standard hospital operating room as well as in an educational setting.
- g. *Ergonomics:* The device must allow the anesthesiologist to easily listen to on headphones to the heart and breath sound amplifier and alter medication dosages up to three meters away.
- h. *Size:* The main operating box cannot exceed a cube size of 15cm x 15 cm x 15cm.
- i. *Weight:* Overall weight of the system cannot exceed 3.0 kg.

- j. *Materials*: Device will be made out of various circuit components including a condenser microphone and a polymer outer housing. The device will utilize a standard stethoscope head and esophageal tube to initially receive sound vibrations. Materials cannot create electrical interference that would jeopardize patient or operator safety.
 - k. *Aesthetics, Appearance, and Finish*: Device needs to be visually appealing. Device should not be exotically colored and follow standard operating room style.
- 2. Production Characteristics:**
- a. *Quantity*: One
 - b. *Target Product Cost*: \$100-\$300
- 3. Miscellaneous:**
- a. *Standard and Specification*: Built to United States legal standards. Must be approved by proper hospital committees and staff to comply with HIPPA and patient disclosure or release. Needs to receive FDA approval.
 - b. *Customer*: Dr. Scott Springman and the anesthesiology staff of the University of Wisconsin-Madison Hospital
 - c. *Patient-Related Concerns*: The device will need to receive proper sterilization between uses as laid out in operating room protocol. If necessary use of device during surgery may need to receive patient approval.
 - d. *Competition*: Multiple similar devices are on the market including products by 3M Littmann Stethoscope, Thinklab Digital Stethoscope, and Cardionics EScope. Prices for competition are not within the price range of the client.

Appendix B: Electronic Circuit Diagram

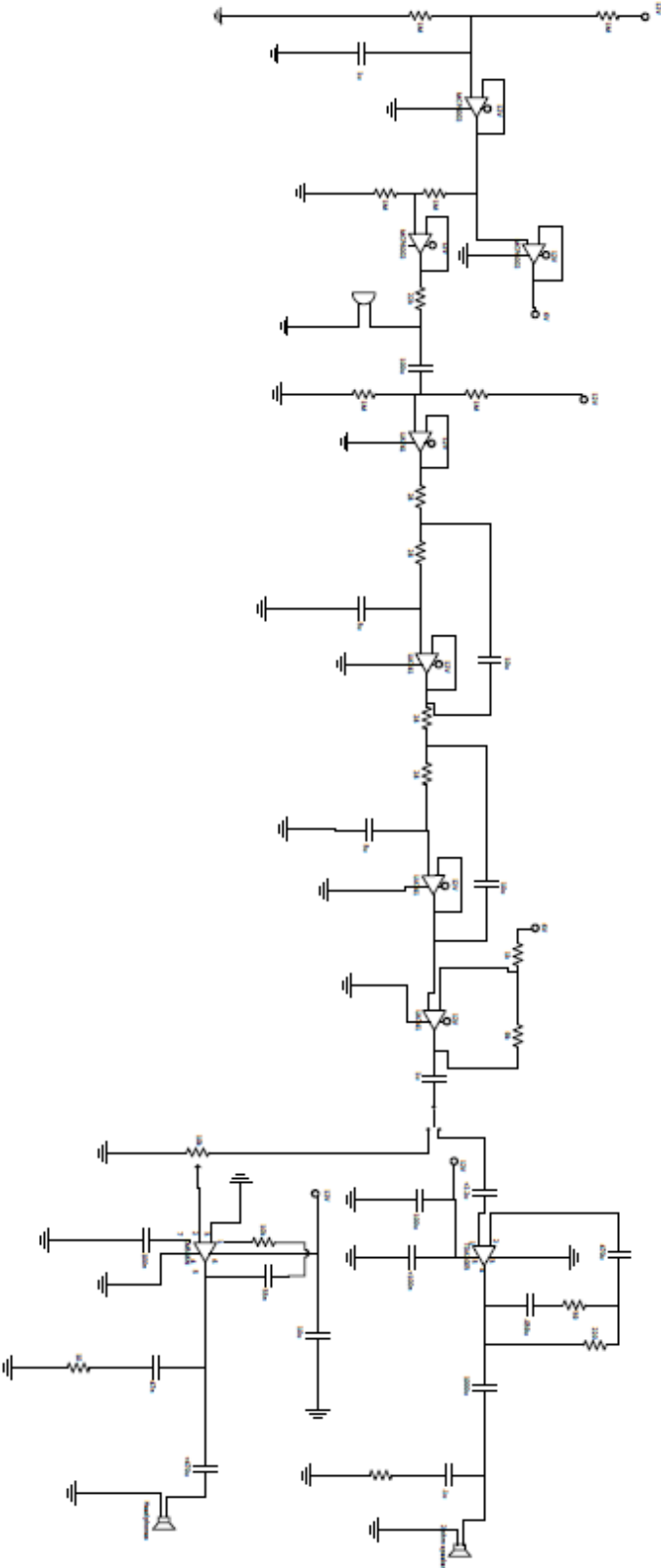

Appendix C: Executive Summary

The Loudspeaker Stethoscope Executive Summary

The standard medical stethoscope is lacking in specific functionality for both clinical and educational settings. Our client, an anesthesiologist, has a clinical and an educational need for a stethoscope that amplifies the heart and breath sounds of his patients. For clinical use, he wants a mobile device with volume control for listening to different sounds. For training medical students and residents he wants to play the sounds through speakers. Our device uses the head of an acoustic stethoscope or an esophageal stethoscope to pick up the sounds, thus maintaining its natural acoustic capabilities. This sound is converted to an electronic signal using a microphone. The signal is then relayed into a small handheld circuit box where it is filtered and amplified. The sound can be heard through a standard pair of headphones or speakers built into the box.

The device meets all four of the client's specifications: adjustable volume, ability to use commercially available headphones allowing the client to use wireless headphones and become "cord-free," two built in speakers, and small enough to be carried in one hand.

The current prototype uses an acoustic stethoscope head and tube which connects to a microphone through a specially designed acoustic coupler. The output of the microphone is filtered and amplified. The speakers or headphones can be selected using a switch. The device is approximately 20cm x 15cm x 20cm. Clinical testing is planned

There are currently multiple electronic stethoscopes on the market. However, this device incorporates two novel features: the capability to move away from the stethoscope while still listening and speakers. This product can serve a unique purpose in the operating room setting, but may have a broader purpose as a teaching tool for medical students, but also students in general. The ability to broadcast heart sounds onto speakers is something no other electronic stethoscope can currently do which gives this device has broad educational applications. Currently, this product has limited intellectual property potential because it is similar to products already on the market including electronic stethoscopes and smart phone applications. However, with the incorporation of new functions as the future design work continues the marketability of the device will increase.