

UNIVERSITY OF WISCONSIN – MADISON
DEPARTMENT OF BIOMEDICAL ENGINEERING
BME 201 – DESIGN

Home Health Device

Mid-Semester Report

Megan Jones – BSAC
Ashley Quinn – BWIG
Sara Schmitz – Leader
Omar Usmani – Communicator

3/9/2011

Table of Contents

Abstract.....	3
Project Motivation.....	3
Project Requirements.....	3
Design Alternatives	4
Design Matrix	8
Final Design	10
Fabrication and Future Work	10
References.....	11
Appendix A – Product Design Specifications.....	12

Abstract

Due to variable home environments in the home health industry, medical professionals are often required to stand for the duration of their visit. The team objective is to design a device which can be transported between homes, can store the equipment and supplies, and serves as a seat. Thus far, the team has outlined design specifications, compiled three design alternatives, used the design matrix to compare these designs, and have chosen a final design to pursue. The final design includes a box with a drawer for storage and adjustable-height, fold-out legs. For the remainder of the semester, the materials will be ordered, the device will be constructed, and tests will be performed to ensure functionality.

Project Motivation

In the home health industry, medical professionals encounter a variety of different home environments. Many times the homes have limited seating and workspace, requiring them to stand for the duration of the visit while simultaneously juggling equipment and supplies. Some procedures performed, such as wound care, require them to bend over and squat for long periods of time. This creates difficulty to the procedures and is uncomfortable throughout the day. Therefore, the project's purpose is to design a device that can be transported between homes, can store the equipment and supplies, and also serves as a seat.

Currently, the team's client carries her supplies in a backpack- sized canvas bag. Medicare regulations require the bag and its contents to be kept sanitary between visits [1]. Some of these regulations include: keeping the bag off the floor, sanitizing one's hands before touching anything inside, and cleaning the bag regularly. At times the patients' homes do not have sufficient surfaces for keeping the bag off the ground. To provide a surface to set the bag or storage off of the ground is another objective for this project.

Project Requirements

The requirements for this project specify that the device must be lightweight so it can be transported easily between homes. In the team's Project Design Specifications, see Appendix A, lightweight was defined as 20 pounds if wheels are not included, and under 30 pounds if they are included. Also, the maximum dimensions for the device should be 18 x 18 x 16 inches, which is approximately the size of the client's current bag. Due to Medicare regulations the device must be easy to sanitize; therefore, materials that absorb liquids easily cannot be used, such as cotton or wood. A seat should also be included to make procedures easier to perform and to relieve the stress of standing for the whole workday. A handle should also be included to facilitate transportation. For the patient's safety, materials that are commonly allergenic, such as latex, cannot be used. Lastly, the client would like to keep the budget around \$100.

Design Alternatives

Design 1: Lawn Chair

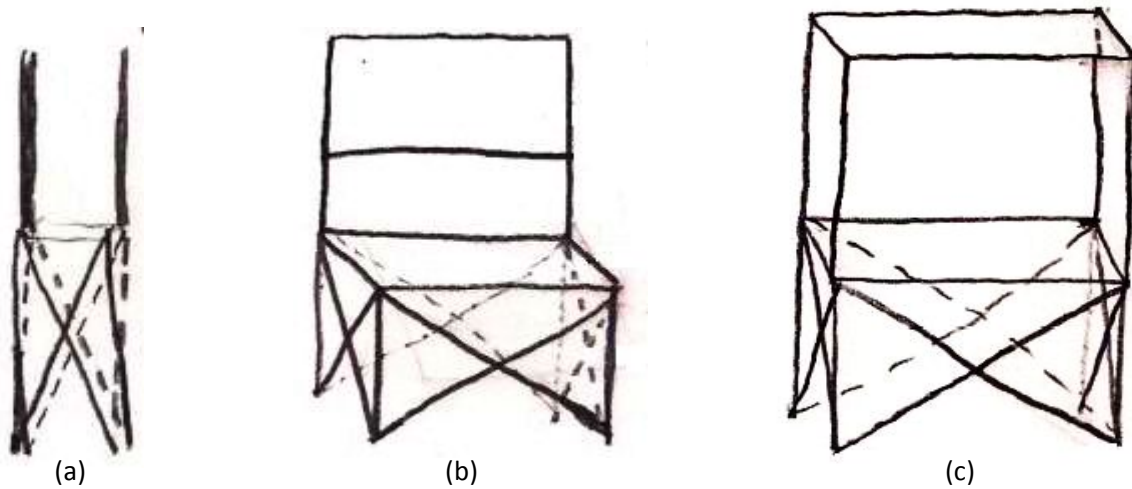

Figure 1: (a) transportation view, (b) sitting view, and (c) standing view

This device would be similar to a typical lawn chair with some key modifications. The first of these modifications would be the addition of a net underneath the seat. The net would be attached at the four intersection points of the eight crossed bars of the base. While the nurse is sitting down and tending to their patient, they could store the bag beneath them in this net so their equipment would be close but not touching the ground. Two pockets that hang off the sides of the seat would also be added to the chair. This would be a place to set the most frequently used equipment during patient care and would minimize the need for the nurse to reach for the bag underneath them. It is important to note that these pockets would not hold equipment during transport, but simply hold equipment that has been removed from the equipment bag and will be used often throughout the visit. The last two modifications to the chair would be the addition of two extensible poles and the ability to detach the two lower corners of the back rest. The extensible poles would have two heights and would pin-lock at each. The lower height would be even with the seat height and would be attached to the front corners of the seat. The second height would be even with the two stationary backrest poles. At this height, the two lower corners of the backrest would be detached and reattached to the extensible poles, as shown in the standing stage of Figure 1(a). This new third tier of the chair would serve as a place for the nurse to set the equipment bag when it is easier to stand and tend to the patient. At this height, the bag is off of the ground and at a more comfortable level so the nurse does not need to bend over to access the equipment. Straps would also be added to secure the bag at this height and hopefully prevent tipping due to unbalanced weight distribution; however this is still a potential risk of this design.

For transport of the device, the bag and all equipment would first be removed and the extensible poles should be in their lower position. The chair could then fold up like a regular lawn chair and be placed in the typical long, thin bag with carrying strap. The obvious disadvantage of this means of transportation is that since the device does not feature permanent storage, the nurse would need to carry both the chair as well as their equipment bag into and out of a patient's home. This would be bulky and could be deemed undesirable by the user. The advantages of this device are that it would be easy and relatively cheap to construct since majority of the components are prefabricated.

Design 2: Box with Drawer

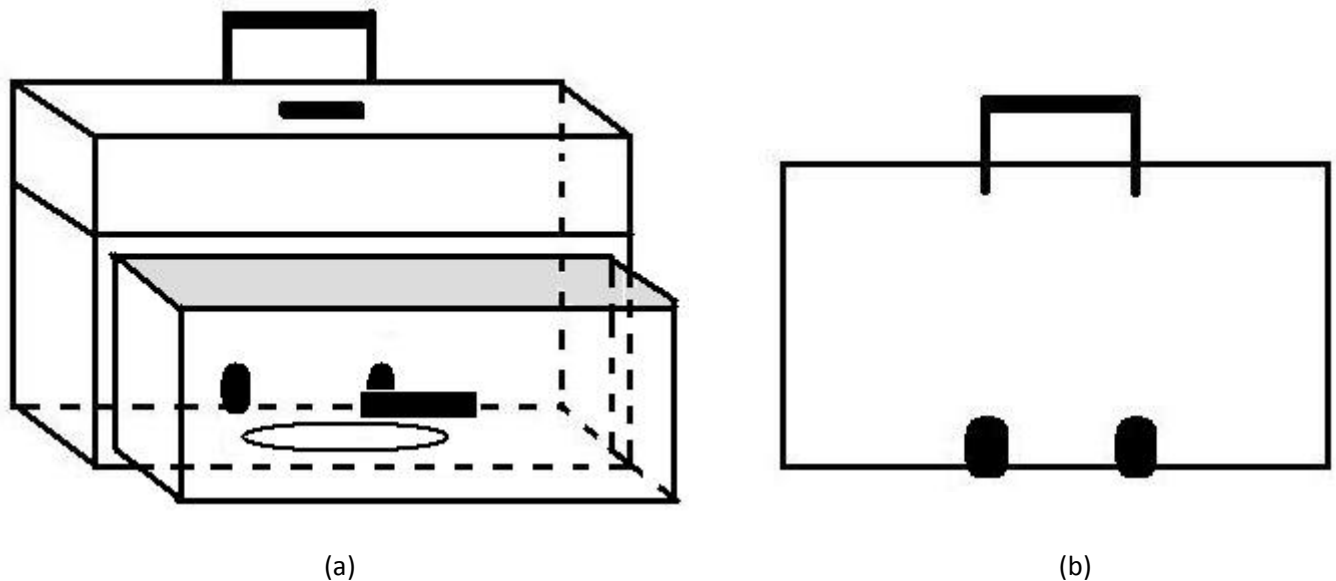

Figure 2: (a) Front view of design with drawer slightly opened. (b) Back view of design showing wheels and handle.

This design features a seat and storage box that would be combined with one of two leg possibilities which will be described later. Either of these legs would attach to a swivel mechanism which would then be attached to the base of the box at the oval shown in Figure 2 (a). The device would also feature wheels and an extensible handle similar to that of a rolling suitcase. These components would be attached at the back of the box as shown in Figure 2 (b). This would allow for easy transport across smooth surfaces. For transportation where wheels cannot be used, such as up or down stairs, the device would feature a handle on the top surface so the device can be easily lifted. This handle would rest in an indented portion on the top since the top will also be used as the seat. For comfort of the user, a stadium seat of canvas or nylon, an example shown in Figure 3, would be set on the top and secured to the box with straps. There would also be a large drawer underneath the seating area. The drawer would either be large enough to hold the entire equipment bag or would include dividers to organize and secure the equipment during transportation. Side surfaces could be attached by hinges or slide out from sides to provide more working surfaces for the nurse and to set equipment. These surfaces would be added based on the client's preference. During transport, the drawer and possible side surfaces would be secure by straps or clips to prevent from opening. The device will be constructed largely of plastic and metal. The advantage of this device is that it is easy to transport since it features permanent storage and the nurse would only have this one device to carry instead of two. One



Figure 3: Example of a stadium seat that can be used as a cover for the device [2]

disadvantage is that the exact design will vary depending on what pre-existing components can be utilized in this design.

Design 3: Box with Flip Top

The third seat design, the box with the flip-top, has similar characteristics to that of the box with the drawer. Figure 4 is the drawing for the flip-top seat design. A storage area will be included in this design providing extra storage space for the team's client where she may place the bag during transportation as well as store supplies if she so desires. A turning component is connected to the bottom of the seat to allow the chair to swivel in different directions during use. Located on the bottom, backside of the seat is a pair of wheels similar to that seen on a suitcase and at the top, backside of the seat is an extendible handle; these components will be used simultaneously for ease of transportation from one place to another. Looking at the right and left sides of the seat are two platforms which will be attached to the side when not in use by either Velcro or a snap. These two platforms will have a hinge mechanism where they may be disconnected and pulled down to provide extra surface area for the client to set her equipment on.

The features which set the box with the flip top apart from the box with the drawer is that the seat will include a flip top which can either remain open or closed. In the closed position, the client may sit or set anything on the seat. When the flip top is opened, it will function as a back rest and another surface will be underneath for someone to sit on. This underlying surface also serves as the opening to the storage underneath. A small semicircular opening will be found at one end of the surface to allow easier lifting.

For the materials used for the seat, a canvas or nylon material covering will be fitted over the seat and will be easily cleaned and sanitized. A slit will have to be made in the cover in order for the flip top to open when the cover is on. The infrastructure will be made of metal and plastic.

Advantages to the flip top design are that it will provide simple transportation of the device as well as provide a storage area to place the bag so that everything may be transported as one object. In addition, its lightweight design will also provide easier transport if the team's client has to lift it off the ground for any reason. Finally, it will be cost efficient due to the fact that there will be use of inexpensive material. Disadvantages for the flip top design are that it would have less convenient access to the storage being that the team's client would have to lift up two different exterior surfaces. In addition, the surface below the flip top may not hold as much weight depending on its design and construction. Careful consideration will have to be employed if designing this seat so it could support the necessary load.

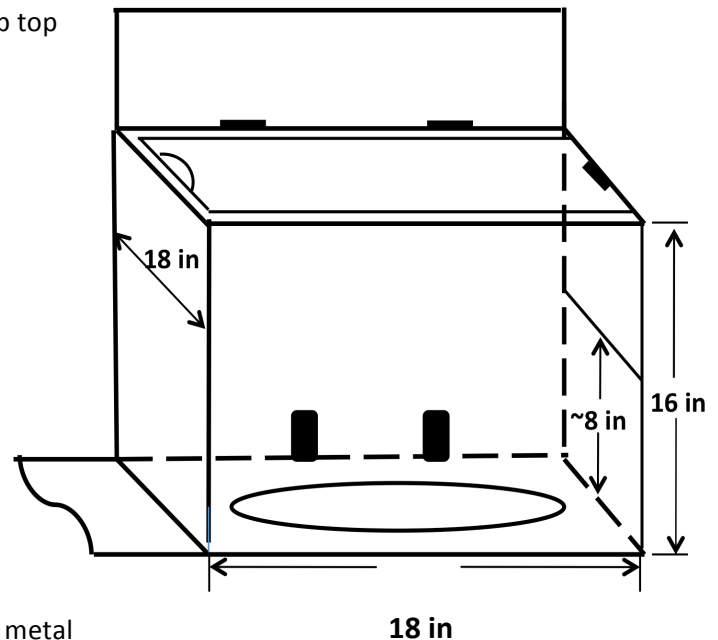

Figure 4: Box with flip-top seat design

Leg Option 1: Adjustable Legs

Regarding the legs portion of the chair, the box seat with the drawer and the box seat with the flip top have two leg options to support the box. First is the adjustable legs design. When not in use, the legs will fold up over each other on the bottom side of the box, as shown in Figure 5(a). To open, the legs are pulled out until they reach the locking point in a standing position. In addition to this standing position, the legs will have an adjusting mechanism much like that seen on crutches where they will have the ability to extend and lock at a desired height. The material for these legs would be a durable metal and feet made of rubber to prevent sliding on a surface.

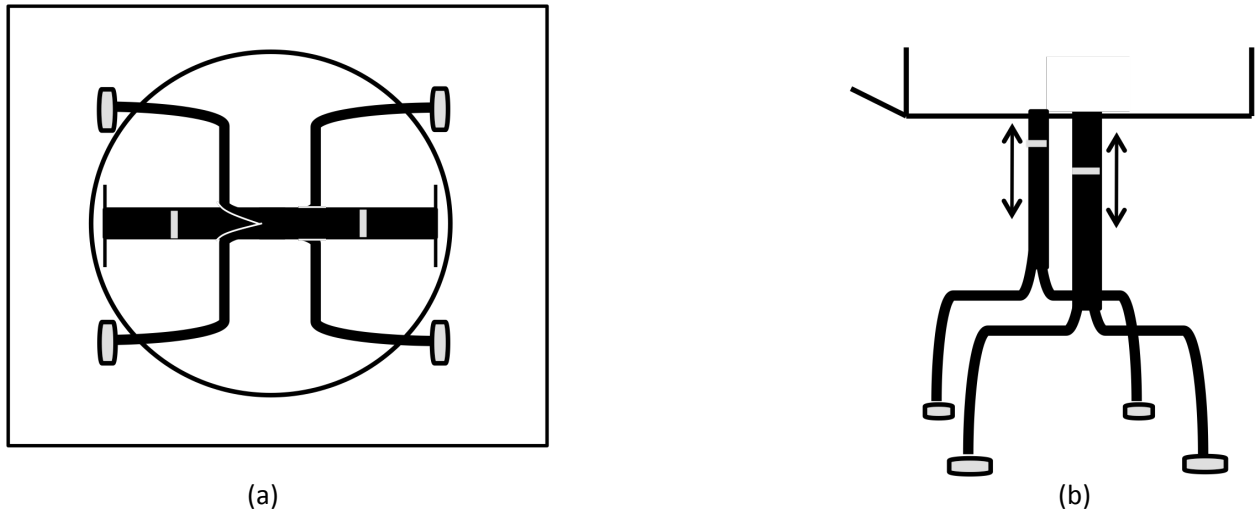

Figure 5: Adjustable legs design: (a) bottom view, (b) side view

Advantages for the adjustable legs design are that they would be sturdy which improves its ability to support the weight of the seat and the person. Based on the distance between the legs and the feet, the adjustable legs would provide optimal balance to the chair. Preexisting legs and material would allow for easy fabrication of these legs and finally, the legs will have height adjustment; depending if the chair is being used for sitting or for setting equipment on, different heights will improve the convenience of the chair. These advantages come with a disadvantage. Since the legs are folded up on the bottom side of the chair when not in use, this may cause inconvenience to open the legs. The seat would have to be tipped to its side to pull the legs out. Overall, the advantages outweigh the disadvantages making these legs a suitable support for the box.

Leg Option 2: Collapsible Legs

The second legs design option is the collapsible legs. Like the adjustable legs, the collapsible legs will also fold up on the bottom side of the box when not in use. With these legs though, a foot pedal will be placed between two feet, as shown in Figure 5, on one side. When one steps on this foot pedal, two side handles located on the sides of the box will be grabbed. Using the side handles, one will pull up on the box until the legs lock at one height in a standing position. A release lever will be used to unlock the legs in order to fold the legs back up after use. For a mental image of these legs, they will be similar in design to that of ironing board legs. The material for these legs will be a metal like the adjustable legs and will also have rubber feet to prevent sliding.

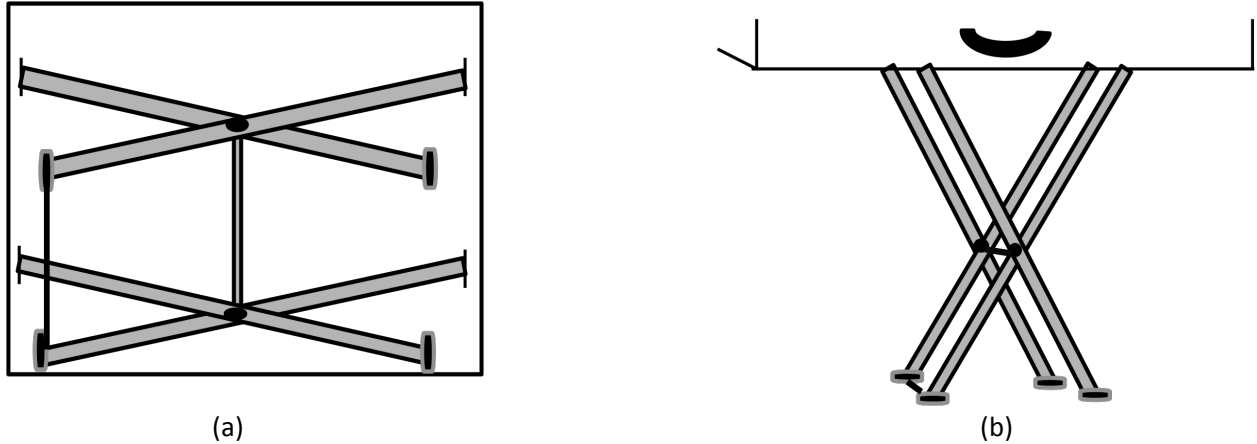

Figure 6: Collapsible legs design: (a) bottom view, (b) side view

Advantages for these legs include good balance based on the distance between where the legs are connected to the bottom of the box which will be the same distance for the feet on the ground. However, if the legs are connected closer together, the overall height of the chair will be higher, making the chair more prone to tip over. Another advantage is the foot pedal and two side handles which will allow someone to open the legs without tipping the box on its side. Once again there are disadvantages to the collapsible legs. First these legs only allow the chair to be used at one height. The team has to be careful in determining the height so that the chair can be comfortably sat on and in reachable access to anything set down on the surface of the seat. These legs would serve as support for the chair, but they may not be as secure as the adjustable legs.

Design Matrix

The three design possibilities were set up in a design matrix, and summarized in Figure 7, so that the efficiency of each design could be demonstrated according to certain criteria that were chosen to be appropriate for the prototype. A total of eight categories were chosen and values were set for each category based on importance; the total of all values was set to be 100.

Weight	Categories	Lawn Chair	Box w/Drawer		Box w/Flip Top	
			Leg 1	Leg 2	Leg 1	Leg 2
15	1) Ease of production	14	10		8	
10	2) Dimensions	8	10		10	
15	3) Cost	14	10		10	
15	4) Ease of transportation	10	14		14	
5	5) Aesthetics	4	5		5	
5	6) Client Preferences	1	5		2	
20	7) Load	13	17	13	17	13
15	8) Adjustability	12	12	7	12	7
100		76	83	74	78	69

Figure 7: Design matrix developed to assess the quality of the design alternatives. Leg 1 refers to the adjustable legs and Leg 2 refers to the collapsible legs.

The category that was chosen to be of the utmost importance was ‘Load (Support and Distribution)’, which was decided to be out of 20 points. It was set to be this way because it was decided that the design’s most important function was its ability to hold up a maximum amount of weight without failure, along with the weight distribution. Out of all three designs, it is important to note that the lawn chair design’s point total for that category was only a 13/20, mainly because the attached lawn chair already has established its ability to maintain a full grown human body and as an engineer, one does not need to and cannot create more mechanisms that would add to its support and distribution.

Another heavily weighted criterion was ‘Transportation Ease/ Storage’, which was out of a point total of fifteen. It is obvious that in order for this particular device to be as user friendly as possible, it must be as portable as possible along with it being able to have all the proposed features. The drawer and the flip top designs received high ratings in this category, but the lawn chair design only received ten points. The reason for a mediocre point total is because the lawn chair does not feature transportable storage; in addition, the amount of storage available would not necessarily be plentiful due to the interference of the lawn chair.

Adjustability was also a heavily weighted criterion. All three designs received a fairly large number of points, except for the collapsible legs for the drawer and flip top designs, which received poor scores, obviously because of the complications that collapsible legs would bring when creating a

final product. Adjustability was considered to be important for the convenience for the nurse as different heights are ideal for different procedures.

Last but not least, 'Cost' was a heavily weighted category, which was also out of 15 points. For this project, financial resources are not plentiful; as mentioned previously, the client is willing to contribute \$100. To meet this price limit, the team should utilize as many preexisting components as possible to save time and money. The lawn chair design was rated the highest, and both the drawer and flip top designs were rated mediocre, mainly because of the extra supplies and resources needed to be bought in order to construct a final product

Final Design

Based on the design matrix, the final design is composed of the box with drawer and the adjustable legs. This combination will most successfully meet the client's requirements and will be relatively easy to produce. Of all possible designs, the drawer is the more preferred storage compartment due to ease of access to supplies. The adjustable legs will be easiest to attach to the box without compromising stability. Many components of this design already exist, such as the cover, wheels, and handles. The team would like to find a suitable box close to the dimensions provided by the client.

Fabrication and Future Work

At this point, a final design has been chosen, however some smaller details of the design must still be finalized with the client. Next, the team will research a number of pre-fabricated parts that can be used to build the final design. Construction of the final design will begin as soon as the biggest components are in the team's possession. Additionally, the ideal attachment points for the legs will be calculated. This process will include the utilization of numerous resources, along with the collection of materials and supplies from different locations. An example of a resource that could be used in the future is the College of Engineering Student Machine Shop which is located in the Engineering Centers Building. Once the actual prototype is complete, testing will be conducted to test functionality. After testing is complete with results that meet initial standards, the remaining work will be directed towards the final presentation.

References

[1] *Bag Technique*. 2008. <<http://nursingcrib.com/nursing-notes-reviewer/community-health-nursing/bag-technique>>

[2] <http://www.bakati.com/s~q-stadium-seats.aspx>

Appendix A: PDS

Product Design Specifications – January 30, 2011

Project #32: Home Health Device

Team Members

Sara Schmitz – Team Leader
Omar Usmani – Communicator
Ashley Quinn – BWIG
Megan Jones – BSAC

Problem Statement

Home health visits can be challenging for a variety of reasons including the amount of supplies needed to be carried along as well as where to place and how to handle the equipment. Additionally, many homes do not have sufficient seating or surfaces necessary for the care giver to work properly. A portable seat and storage device would help minimize these problems and lead to an overall improvement of the quality of the home health visit.

Client Requirements

- Portable; lightweight
- Approximate Dimensions: 18in x 18in x 16in
- Easily Cleaned
- Handle and Seat

Design Requirements

1. Physical and Operational Characteristics

- Performance Requirements:* The device should be able to withstand an average person sitting and moving the device for a twelve to fourteen hour day for approximately one weekend per month.
- Safety:* For safety of the user, the device must comply with OSHA regulations. For sharps and biohazard equipment, there should be separate compartments with proper identification for each. The device should be sufficiently stable and stationary for the weight of an average person plus the weight of the equipment.
- Life in Service:* The overall device should last many years with minimal part replacement.
- Operating Environment:* The completed device will be used and stored at room temperature in a home setting. The base of the device should have minimal contact with the ground without jeopardizing its integrity.
- Ergonomics:* The device should be lightweight and easily moved through any home environment. It should be at an accessible level while the user is sitting on or standing near it.

f. *Size*: The device should be 18in x 18in x 16in when in transport. g. *Weight*: The device and its contents should not exceed 20lbs. If wheels are included in the design, the maximum weight could increase to 30lbs.

h. *Materials*: The material for the device should be easily sanitized, non-absorbent, and comply with Medicare bag regulations. No parts can include latex, cotton or wool.

i. *Aesthetics*: The color of the device should be white or red. Sharp corners are not allowed.

2. Production Characteristics

a. *Quantity*: One prototype is required at this time.

b. *Target Product Cost*: Approximately \$100.00, but is negotiable.

3. Miscellaneous

a. *Standards and Specifications*: OSHA approval and Medicare bag regulations

b. *Customer*: The client would like to include as many of the following features as possible: back support, cushion seat, adjustable height, wheels for transportation, and swivel ability.

c. *Patient Related Concerns*: Medicare requires that all equipment must be sterilized between uses.

d. *Competition*: Some components may reflect current products, however none of these are related to home health visits.