

Quad Rat Monitor

Matthew Bollom John Renfrew
Kenneth O. Xu Gabriel Bautista

Advisor: Dr. Amit Nimunkar
Client: Dr. Alex Converse

Overview

- PET Imaging of Rats
- Device Requirements
- Existing Devices
- Motivation
- Timeline
- Hardware
- Interface
- Housing
- Future Work

PET Imaging of Rats

- Positron emission tomography (PET) scans monitor location of radiotracers in rat's brains
- Client scans four anesthetized rats at a time
- Monitoring the vitals in real time is necessary to maintain health



PET scanner at Harlow Primate Lab

Device Requirements

- Non-invasive probes and user-friendly interface
- 4 rats simultaneously
- SpO₂ levels: $\pm 2\%$ accuracy
- Heart rates up to 500 BPM
- Respiratory rates of 20-30 BPM
- Rectal temperatures of 93-100°F

Existing Devices

- Client currently uses rudimentary devices to monitor vitals
- Available: MouseOx
 - Pulse oximeter for mice and rats
 - Over \$7000
 - Measures only one rat at a time



Motivation

Each rat is under anesthesia during testing, which requires manual adjustments by the laboratory assistants. The development of a system that displays the current values of each vital sign along with the histories would be beneficial in maintaining the rat's health throughout the testing.

Timeline

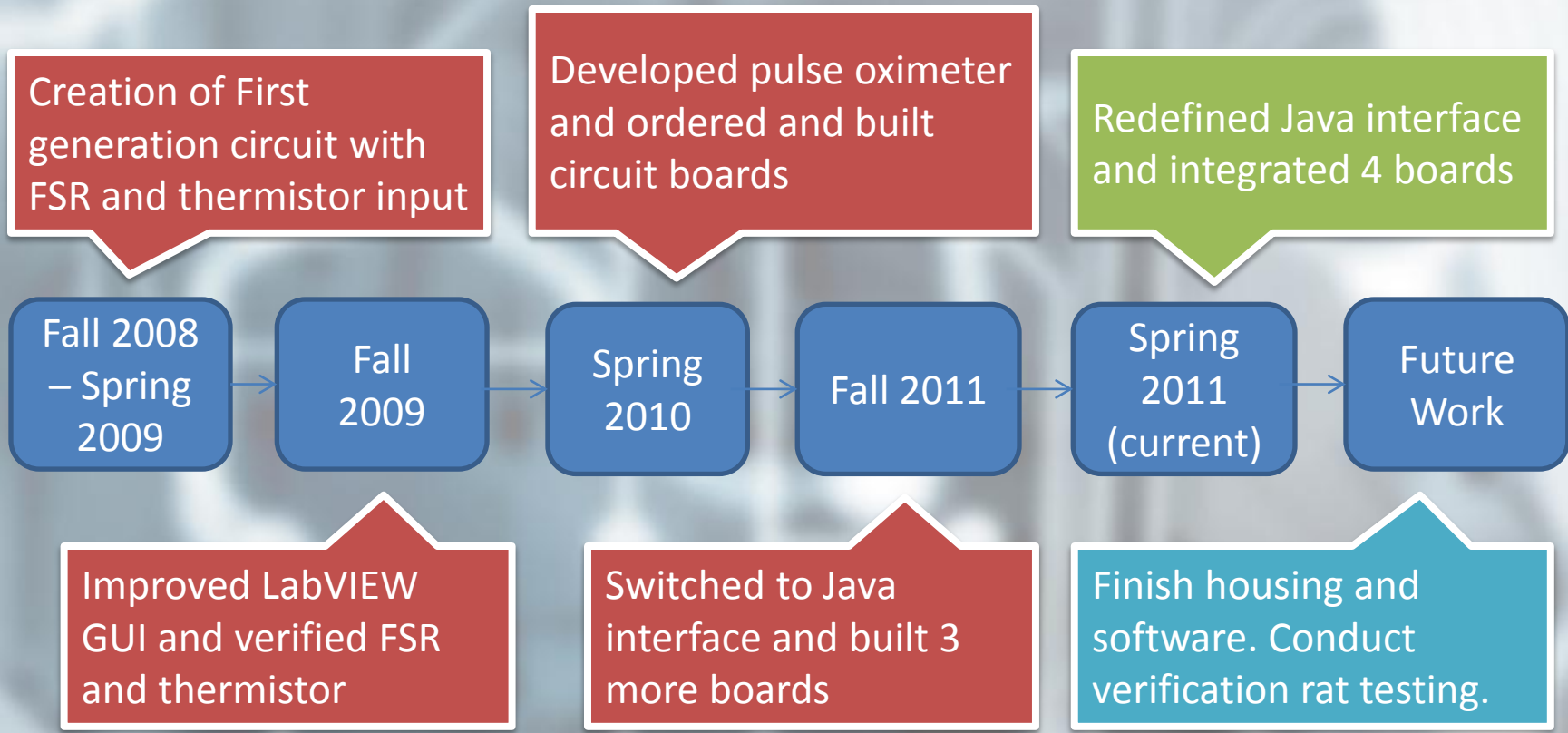

Circuit Progression

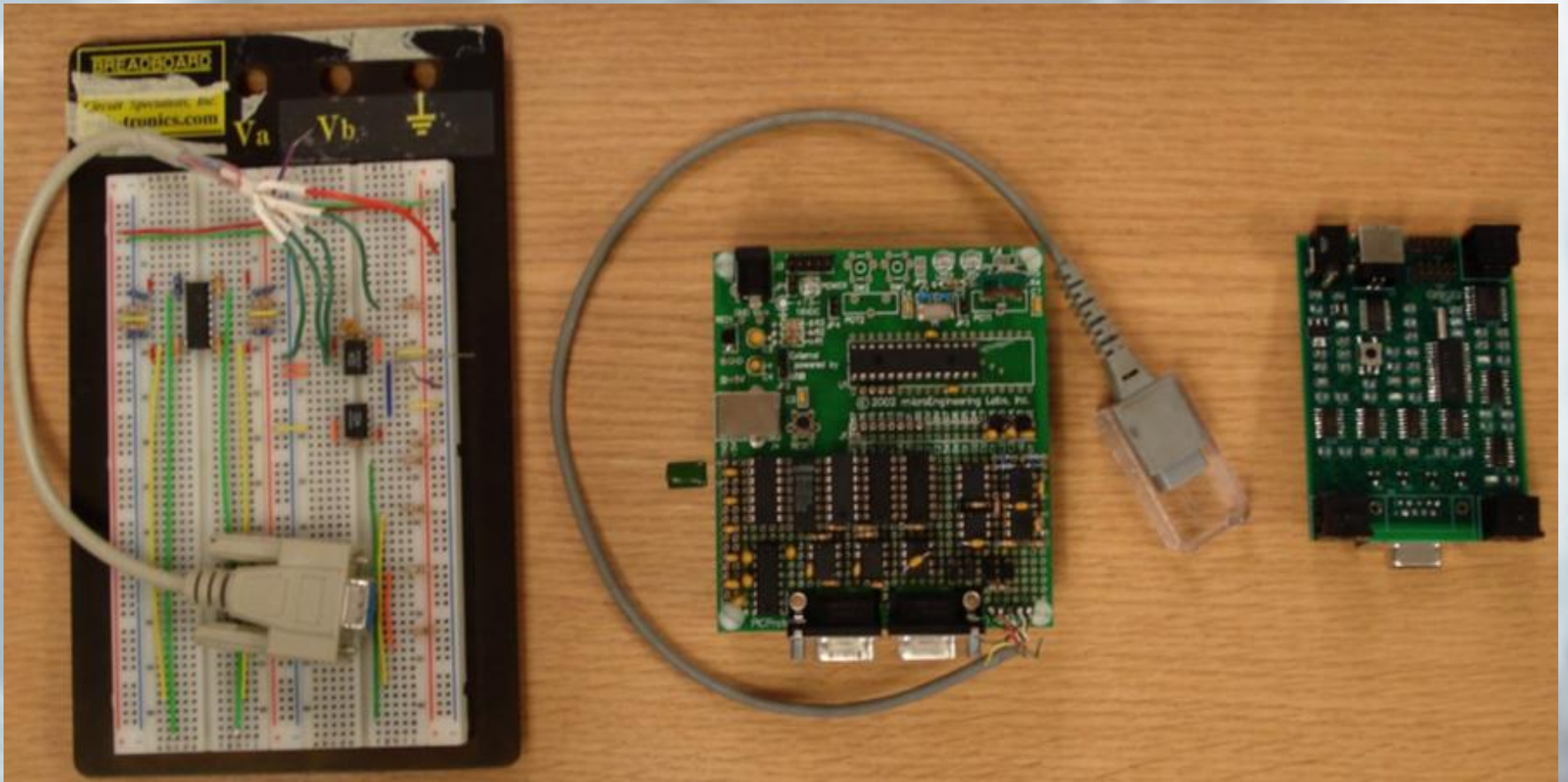

Hardware

- Built and debugged 4 identical circuit boards
- Firmware mostly complete
 - Autogain and I²C remain
- Potentially need to improve data output format

System Master

- “Master” microcontroller (eg mbed)
- Power distribution system
- Communicates with slaves via I²C
- Will output data via USB and/or Ethernet

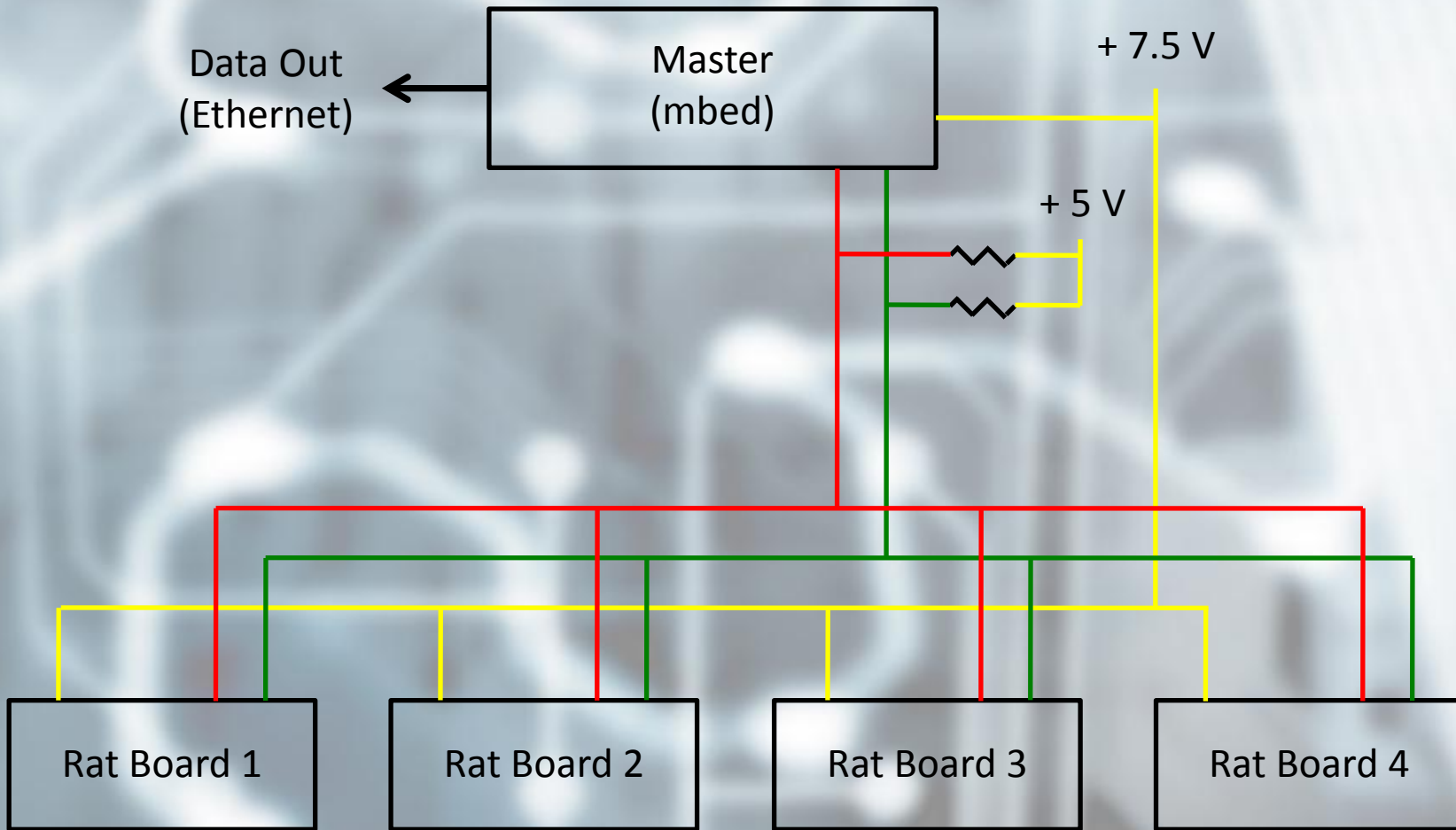

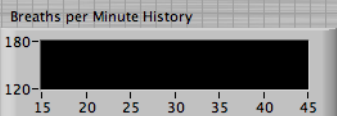
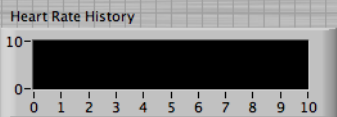
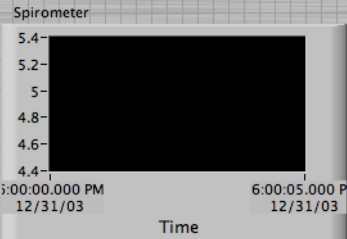

Heart Rate
0

Breaths per Minute
0

Temperature
0

SpO2
0

Rat 1

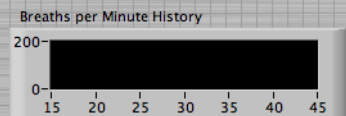
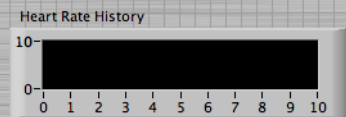
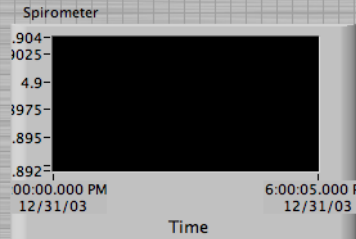
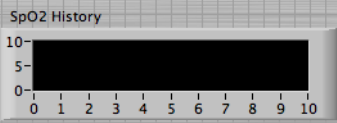
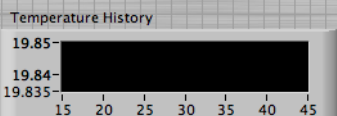
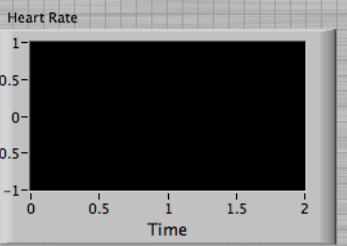

Heart Rate
0

Breaths per Minute
0

Temperature
0

SpO2
0

Rat 2

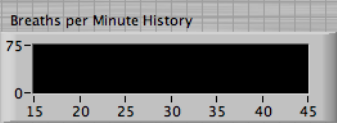
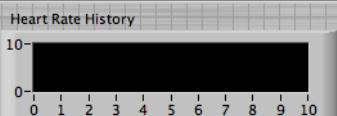
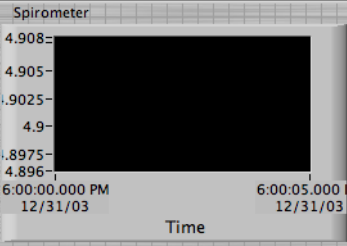
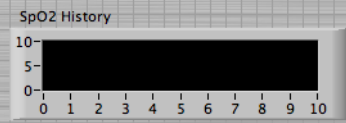
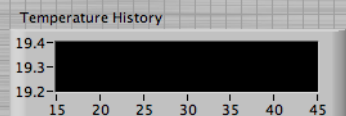
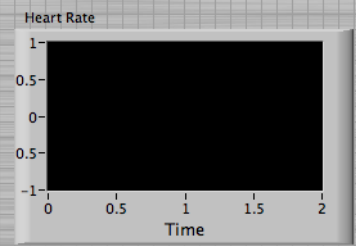

Heart Rate
0

Breaths per Minute
0

Temperature
0

SpO2
0

Rat 3

Adjust Scaling

Minutes to View
0

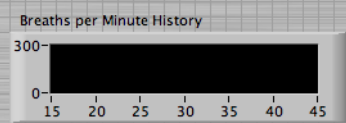
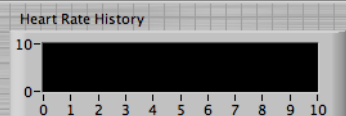
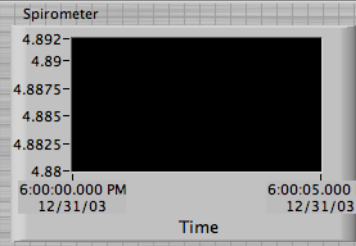
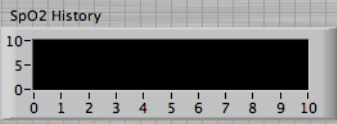
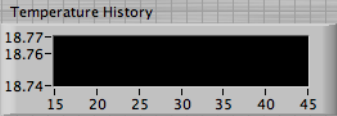
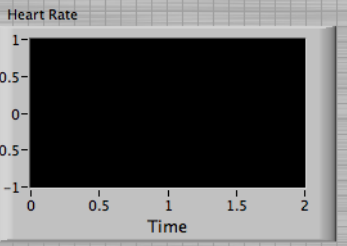

Heart Rate
0

Breaths per Minute
0

Temperature
0

SpO2
0

Rat 4

Marker Saving

Mark

STOP



Red

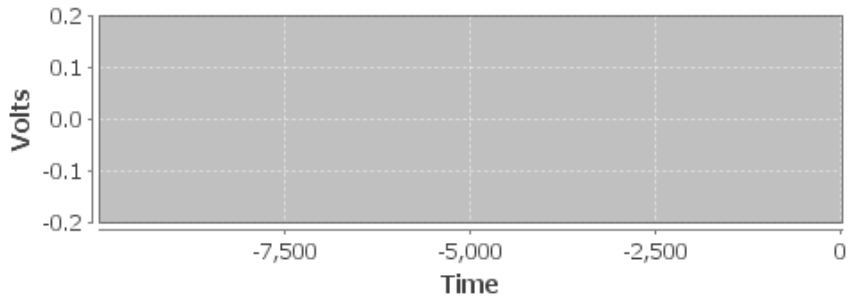

Thermistor

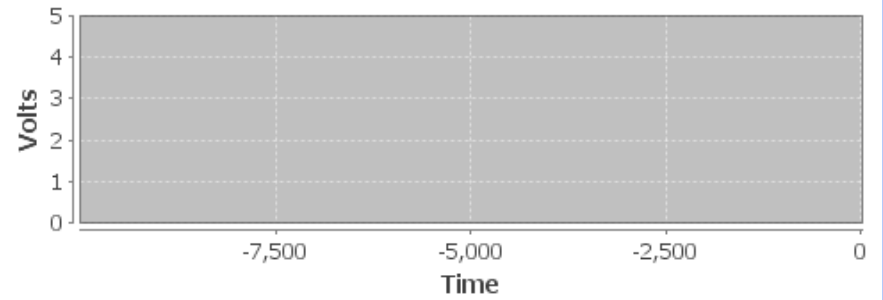

Infrared

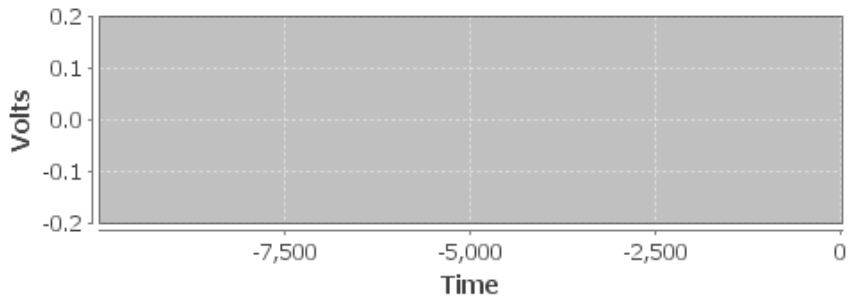

FSR

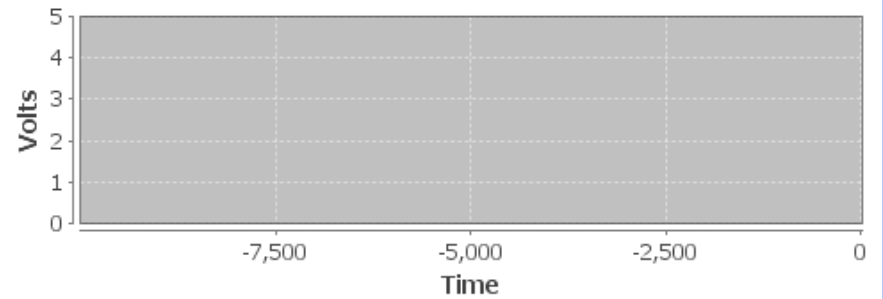

Heart Rate:

SpO2:

Temperature:

Breathing Rate:

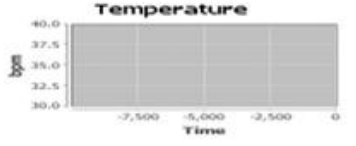
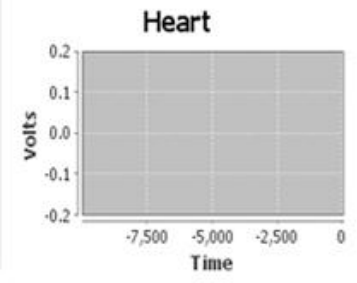
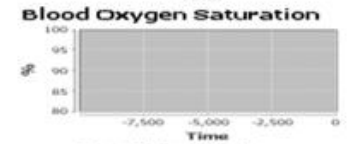
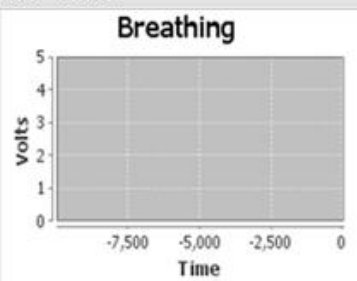

Heart Rate:
SpO2:
Temperature:
Breathing Rate:

Rat 1

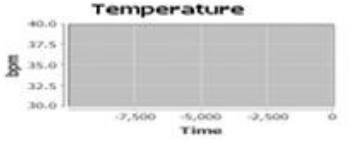
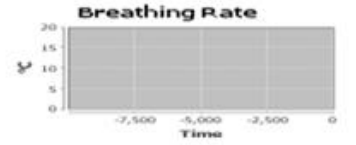
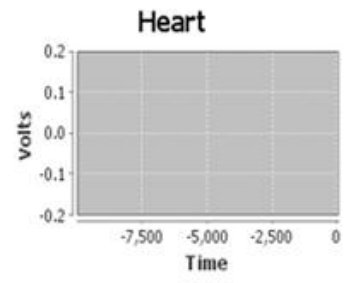
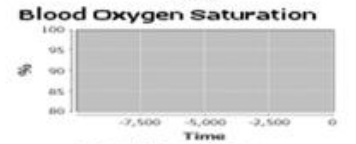
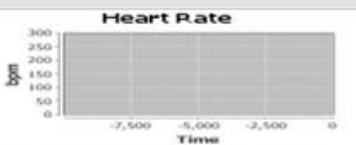
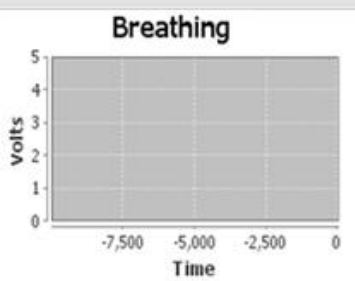

Heart Rate:
SpO2:
Temperature:
Breathing Rate:

Rat 2

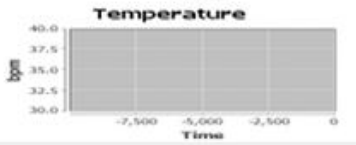
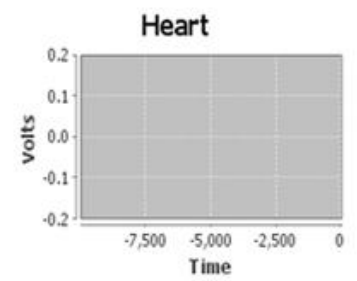
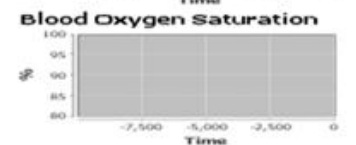
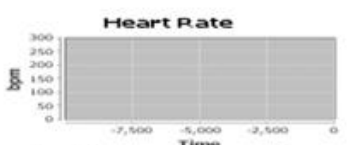
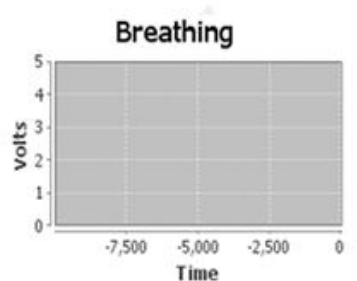

Heart Rate:
SpO2:
Temperature:
Breathing Rate:

Rat 3

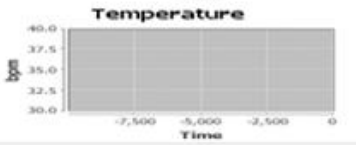
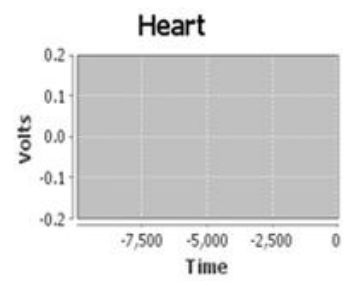
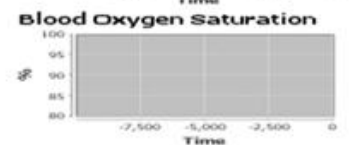
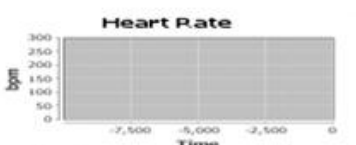
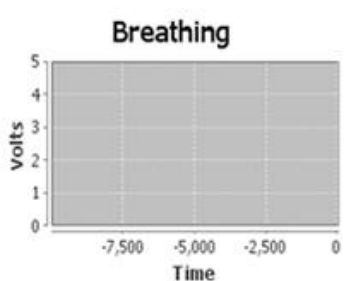

Heart Rate:
SpO2:
Temperature:
Breathing Rate:

Rat 4

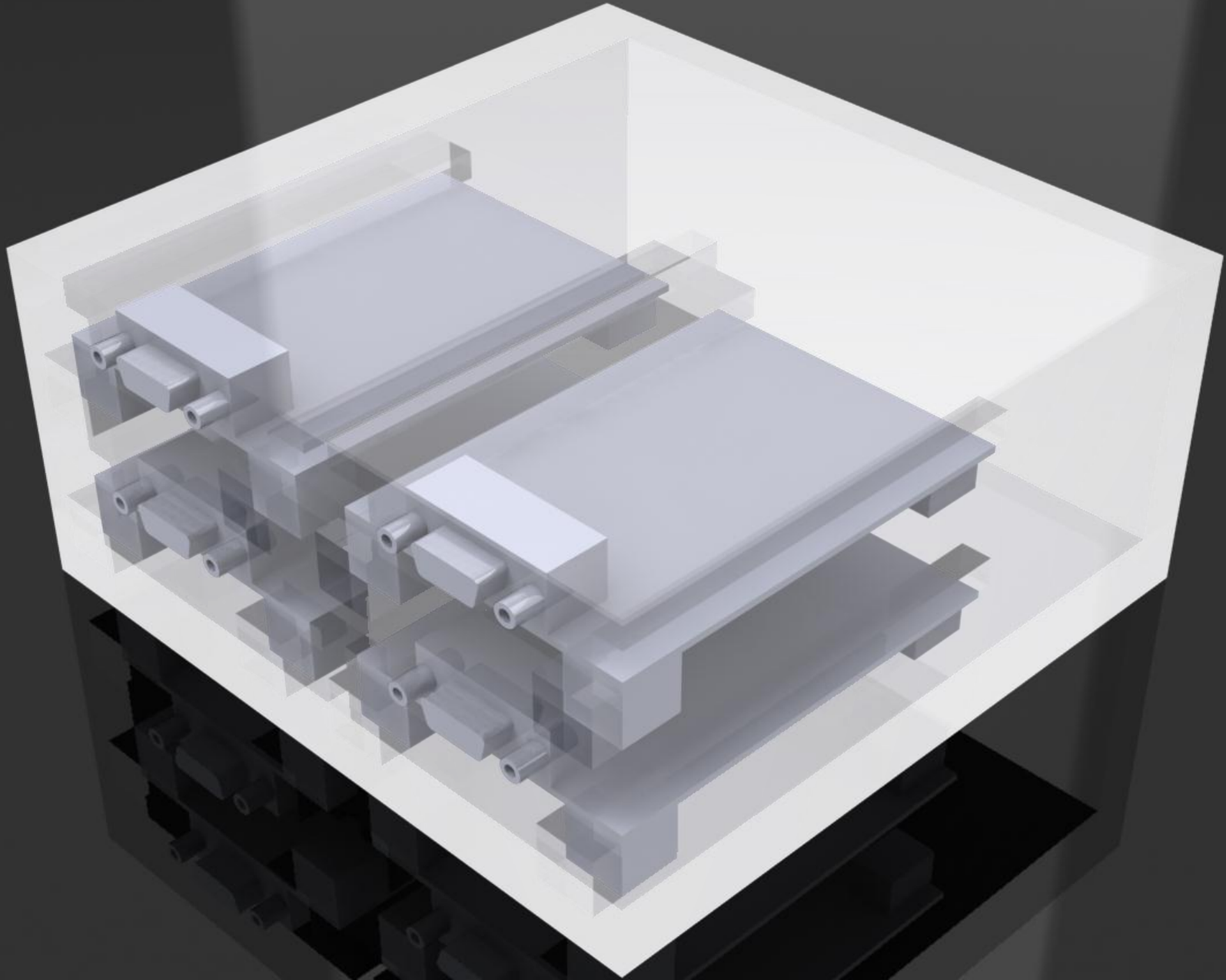

Future Work

- Program master and I²C
- Build housing
- Finish interface
- Improve algorithms
- Verification testing
- User manual

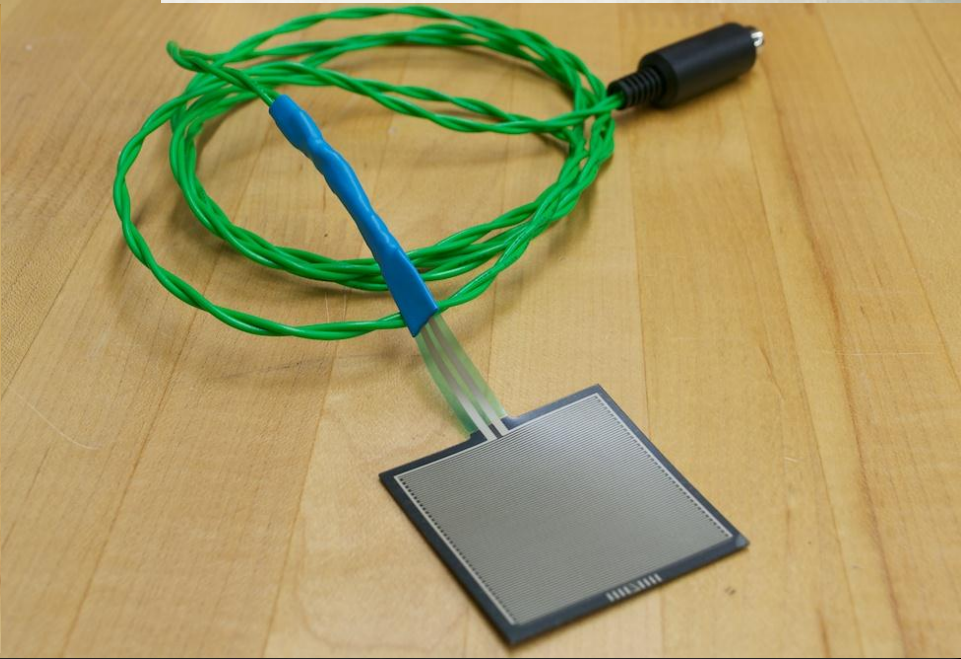
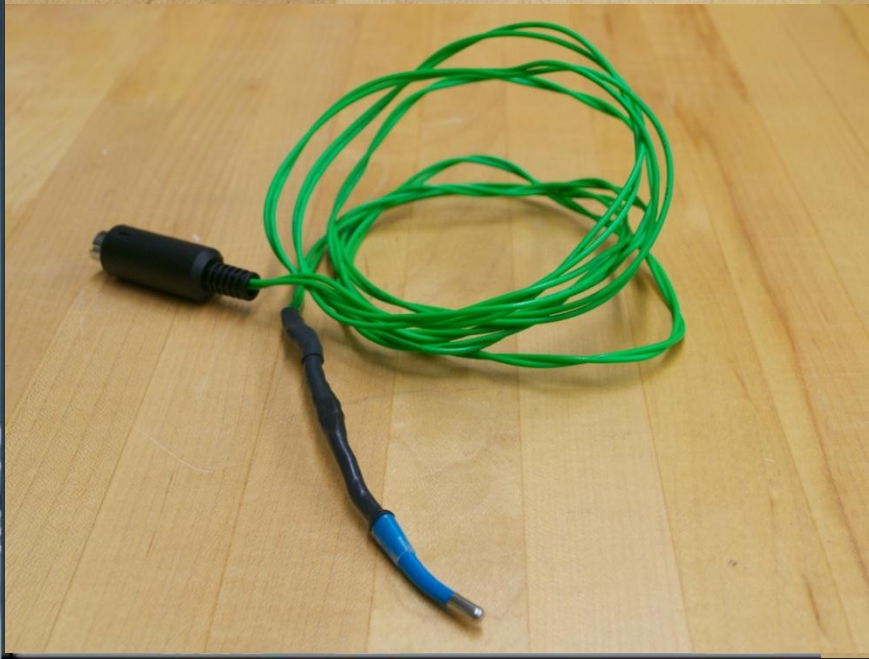
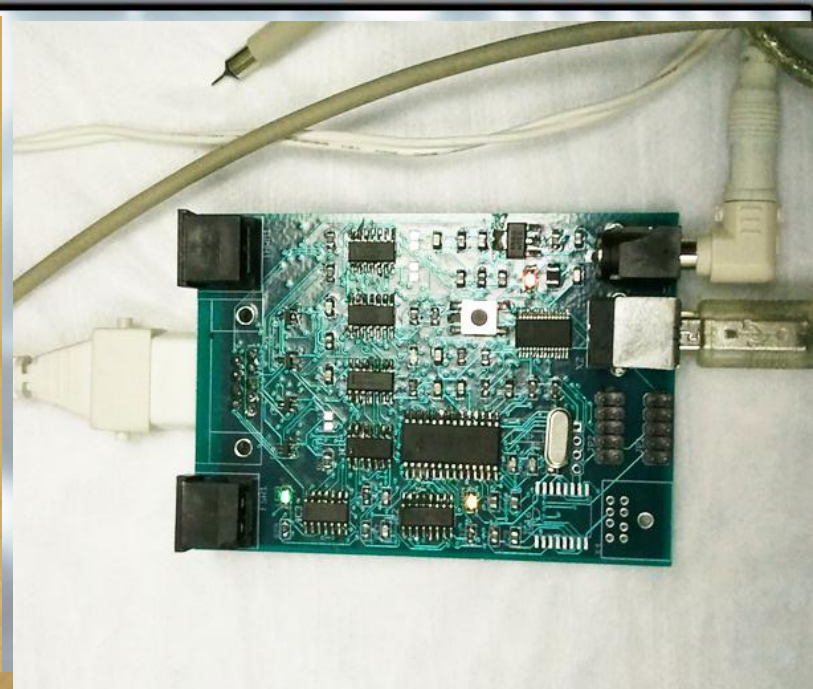
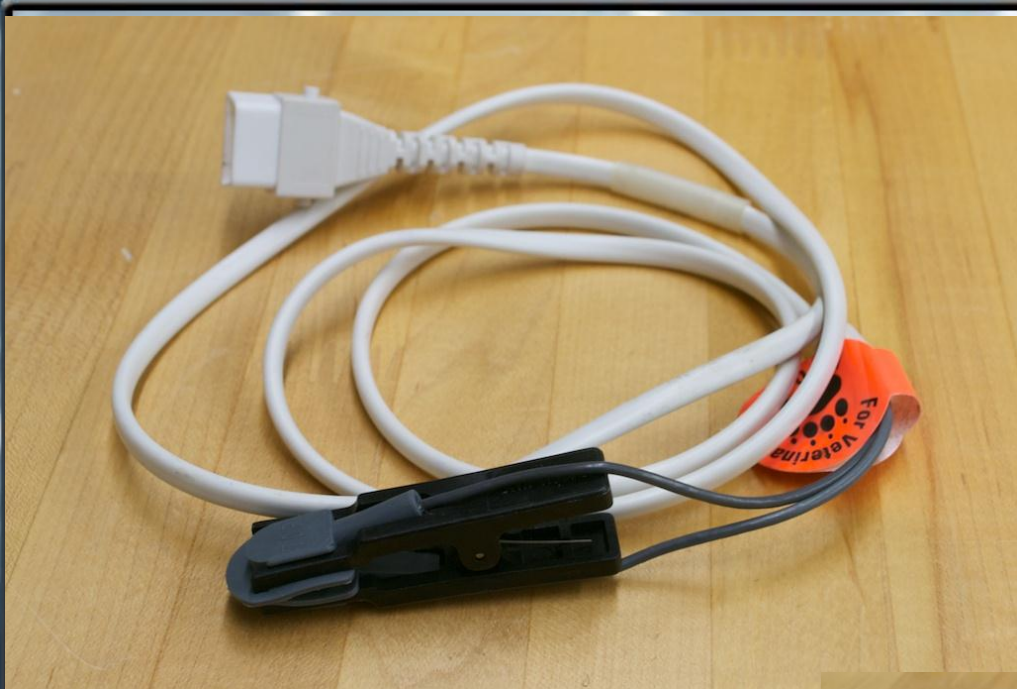

Acknowledgements

- Amit Nimunkar
- Peter Klomberg
- Dr. Alex Converse
- Liz Ahlers