

Laparoscopic Screen Pointer

Client:

Haggi Mazeh
Dept. of Surgery
UW Madison Hospital

Advisor:

Amit Nimunkar

Team Members:

Ryan Nessman
Jacob Meyer
David Schreier
Jeff Theisen



Overview

- Background
- Design Criteria
- Design Alternatives
- Decision Matrix
- Final Design
- Future Work

Background - Laparoscopic Surgery

- Hands are busy operating tools
- Surgery is viewed on video screen
- Multiple surgeons working together
- Training residents
- Communication is essential



<http://www.weightlossurgerychannel.com/breaking-wls-news/gastric-sleeve-procedure-under-scrutiny-at-bariatric-surgery-conference.html/>

Problem Statement

- To modify a video signal for laparoscopic surgery to add a user-controlled pointer.

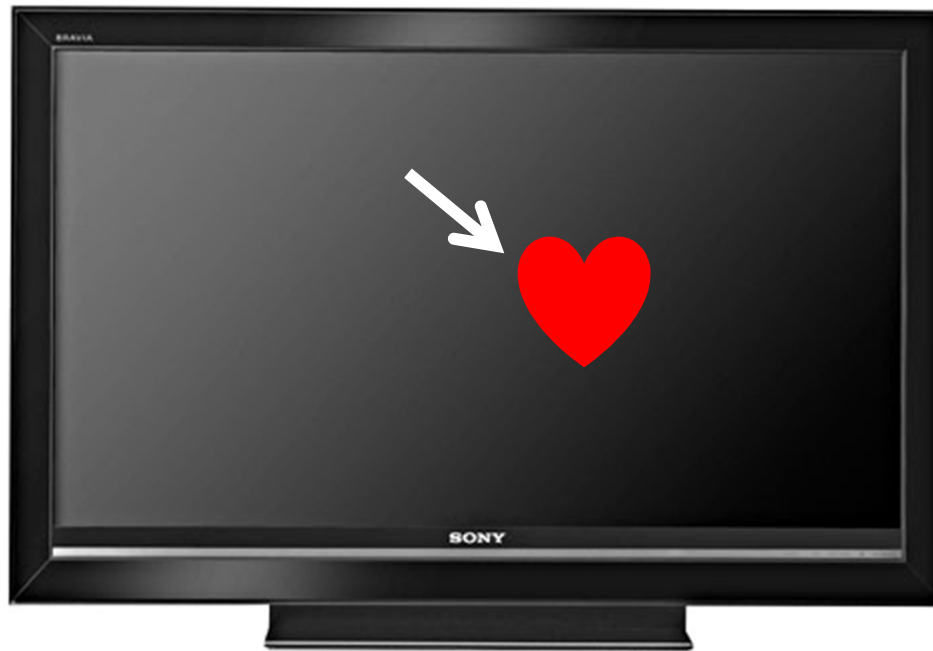

Current System

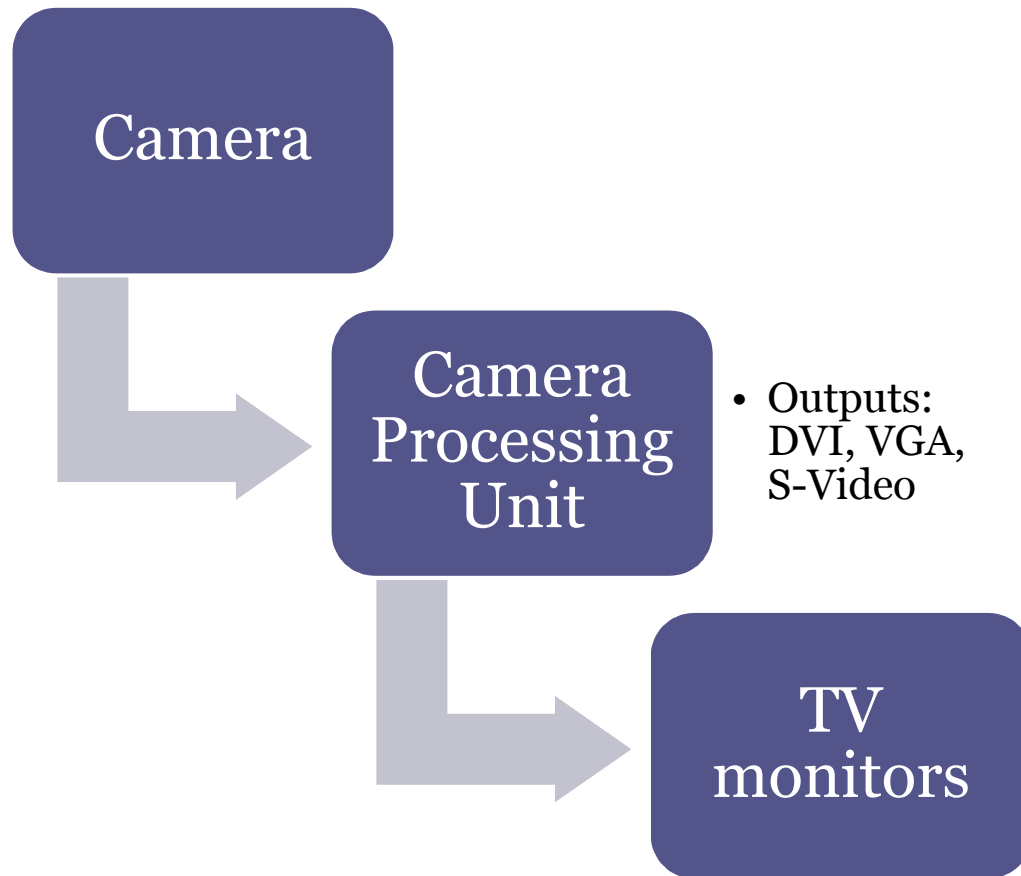

- Communication Problem:
 - Surgeons must drop tools to point at screen



Design Criteria

- Create a system to embed a pointer onto a video signal
- Pointer-controller should attach to current handheld camera



Design Criteria

- Controller use should be intuitive
- No Video Delay
- Should not hinder surgeons ability to operate camera and laparoscopic tools

Design Option 1 - Video Pointer

- Use existing video pointer
 - Requires video signal converters
 - Uses analog signal

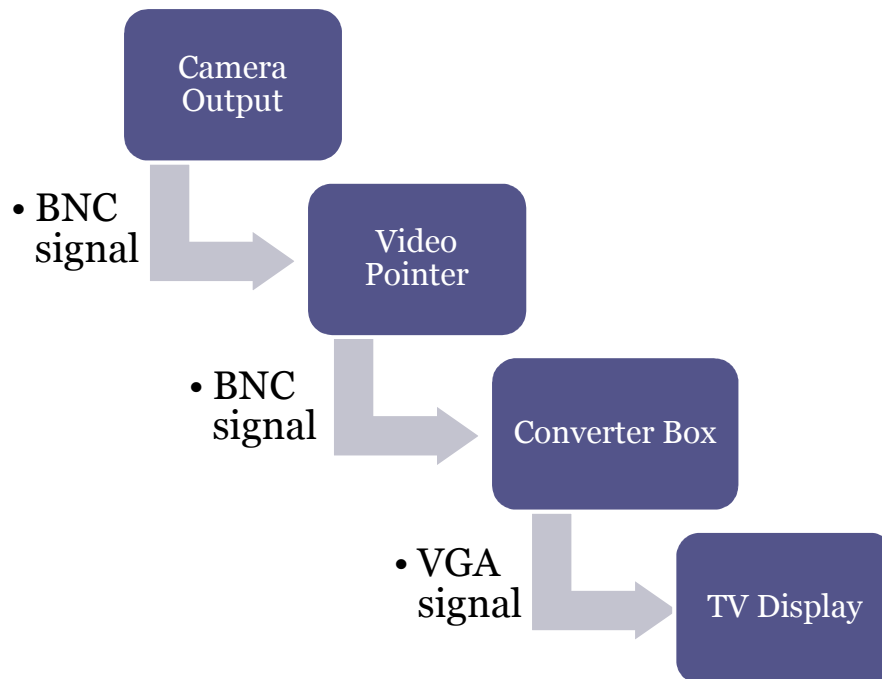

Design Option 2 - Laptop Interceptor

- Use laptop software with additional hardware
 - Requires a video capture device

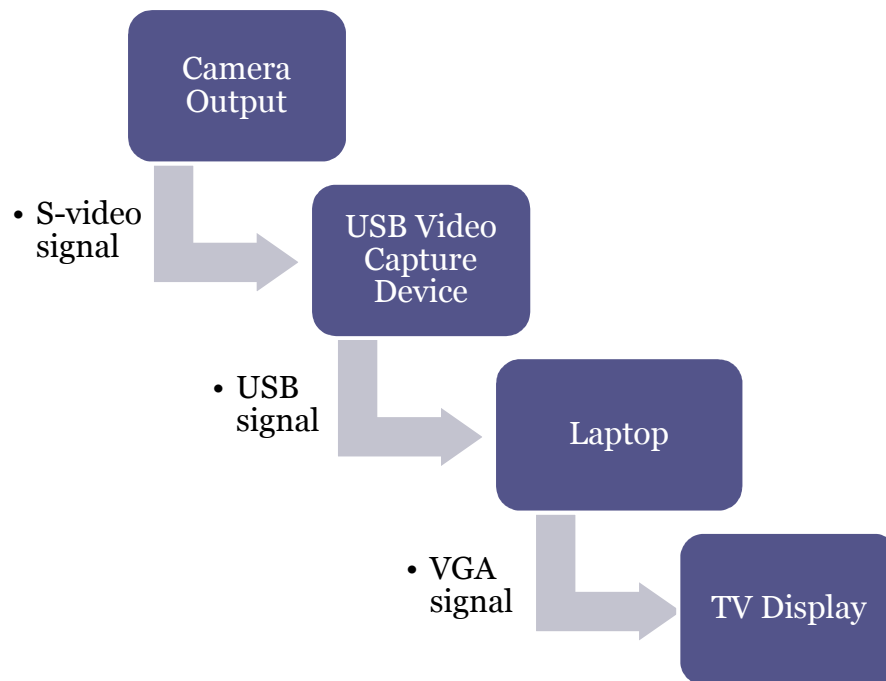

Design Option 3 - Custom System

- Use existing electronic components to design our own system

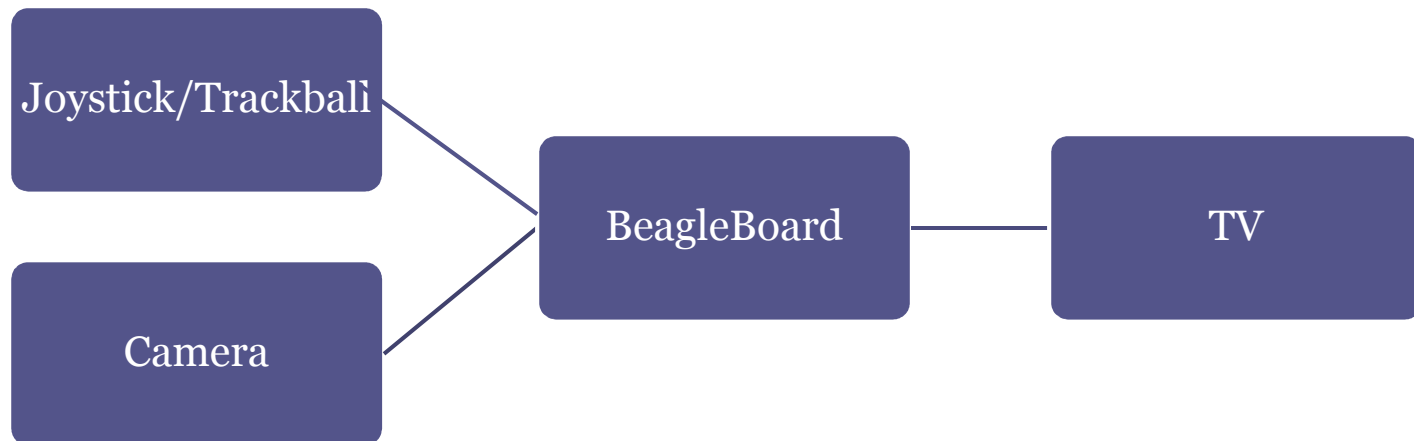

Decision Matrix

Criteria		Possible Designs		
Considerations	Weight	Video Pointer	Laptop Interceptor	Custom Designed
Safety/ No time delay	35	32	25	29
Feasibility	10	9	9	5
Replicability	25	12	20	24
User Simplicity	10	1	7	9
Cost	15	13	11	12
Patentability	5	0	0	3
Total	100	67	72	82

Final Design

- Custom system
- Trackball controller
- Requires programming

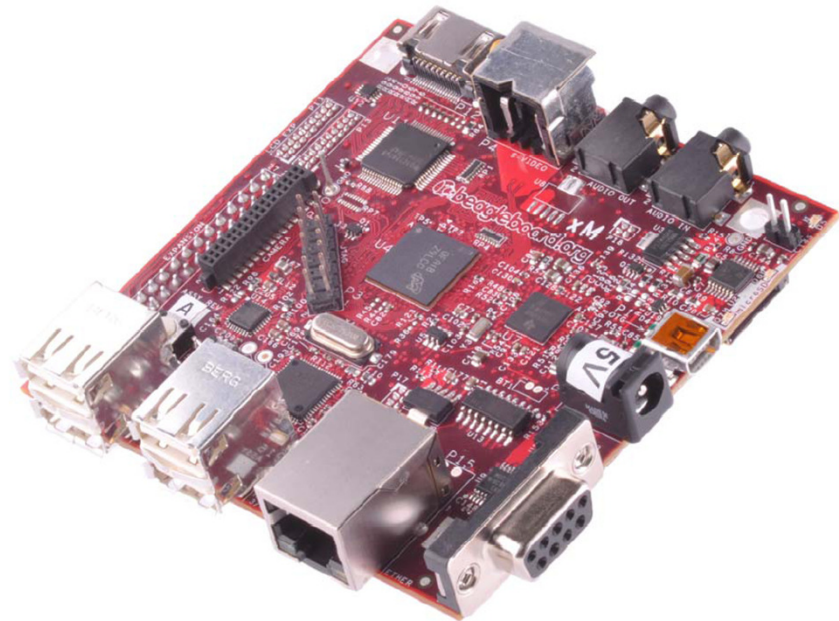

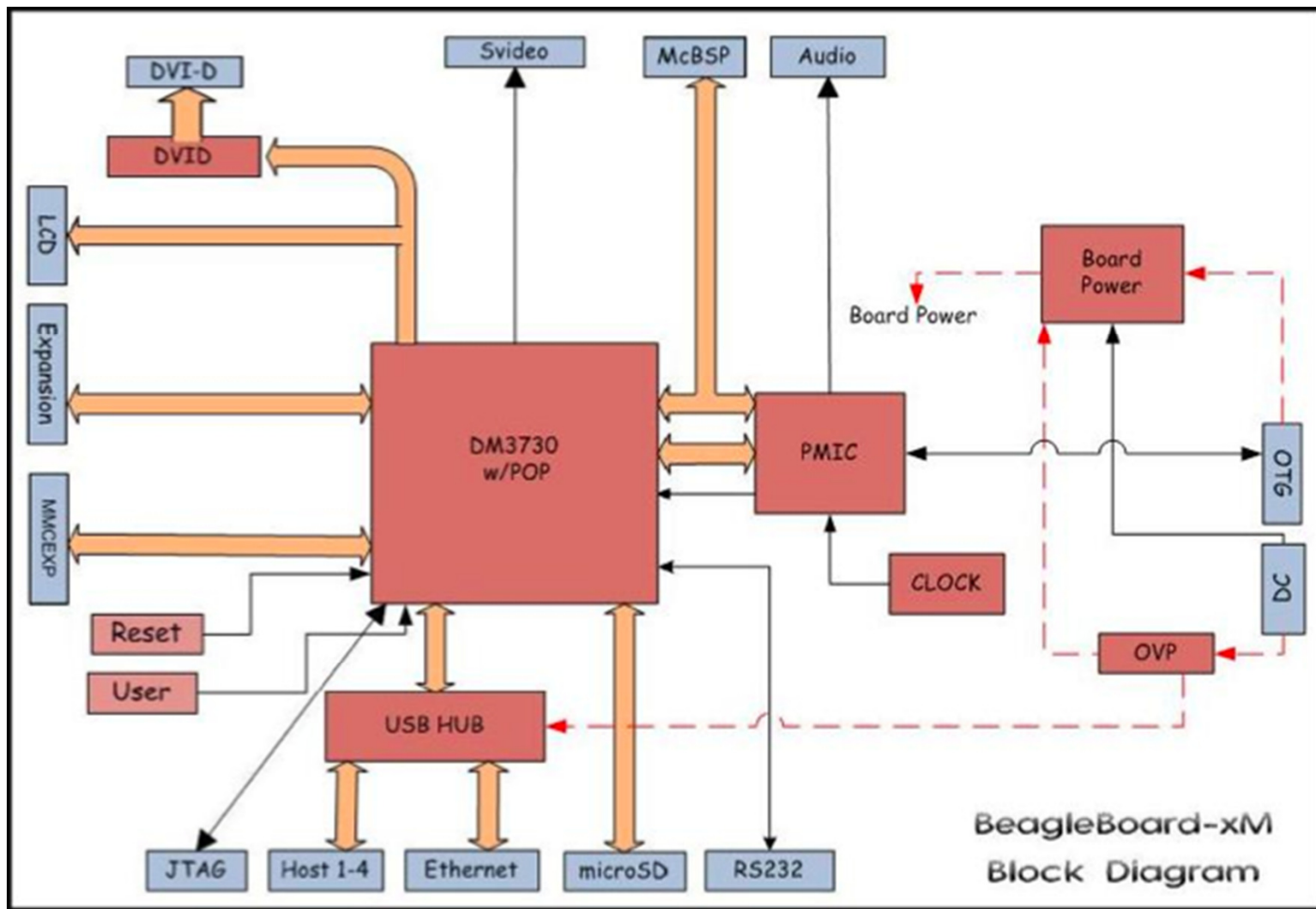

Figure 18. BeagleBoard-xM High Level Block Diagram



Future Work

- Purchase Parts
- Program BeagleBoard
 - Interface to USB trackball
 - Interface to VGA video signal
- Modify trackball for attachment to camera
- Test



Acknowledgments

- Amit Nimunkar
- Haggi Mazeher
- Dusty Smith and the media center staff

Questions?

