

Standing Paraplegic Omni-directional Transport

Justin Cacciatore, James Madsen, Michael Konrath, Bret Olson, Blake Marzella

Advisor: Professor Amit Nimunkar

Clients: Dr. Cuppels, Dr. Jones



DEPARTMENT OF
Biomedical Engineering
UNIVERSITY OF WISCONSIN-MADISON

Standing Paraplegic Omni-directional Transport ...



<http://www.youtube.com/watch?v=gK52RkbGw9s>

Standing Paraplegic Omni-directional Transport (SPOT)



Current Status of the Project

Base Design & Fabrication

- Materials
 - Aluminum & Steel
- Components
 - Mecanum Wheels
 - Toughboxes
- Contains
 - Motors
 - Motion Controller
 - Batteries
 - Brakes

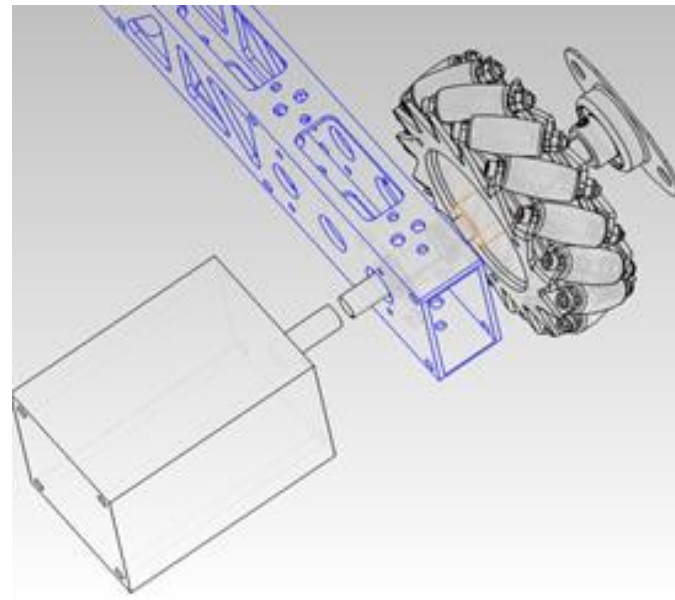

Base Safety Analysis

Free Body Diagram

DR. CUPPELS

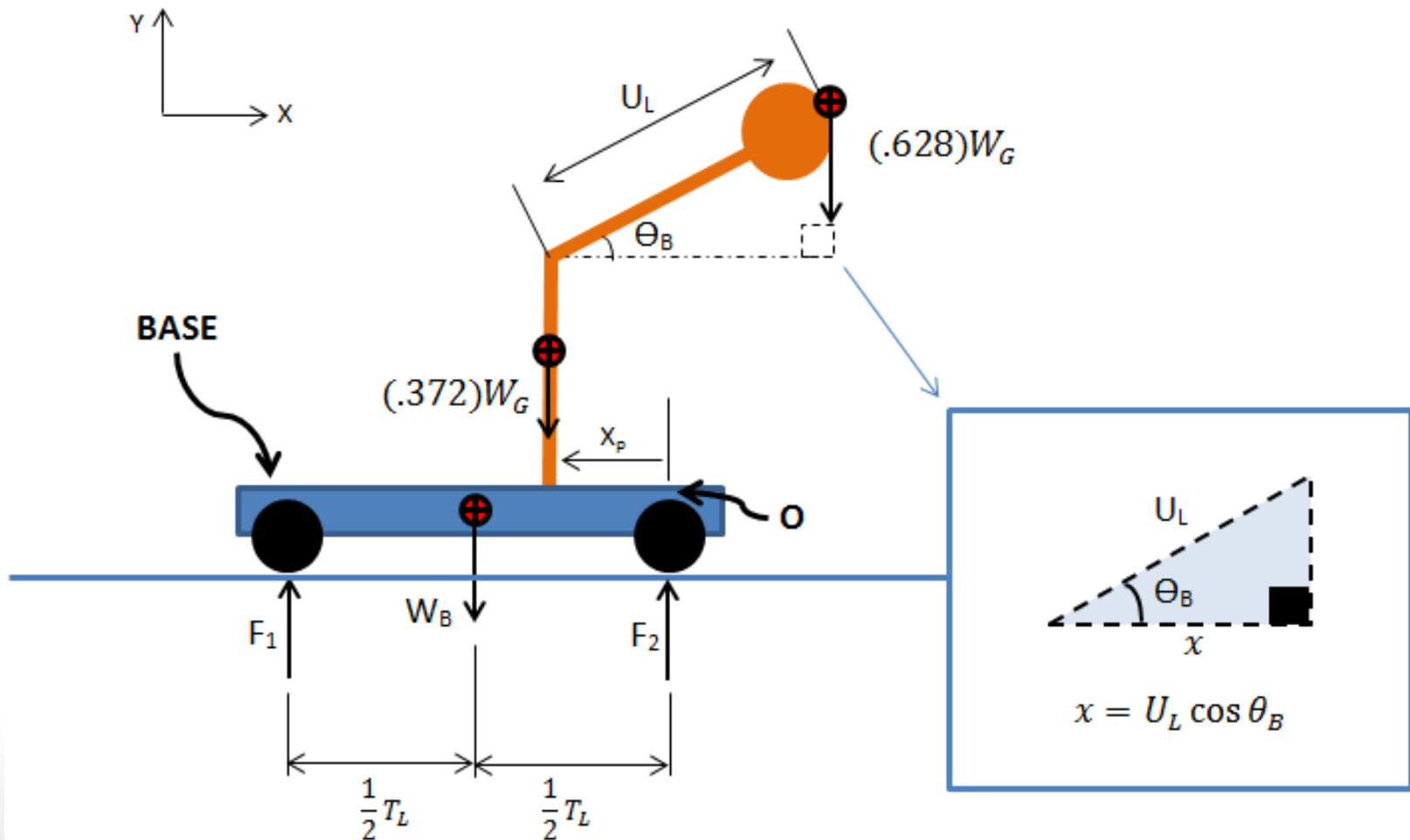

Circuit Design

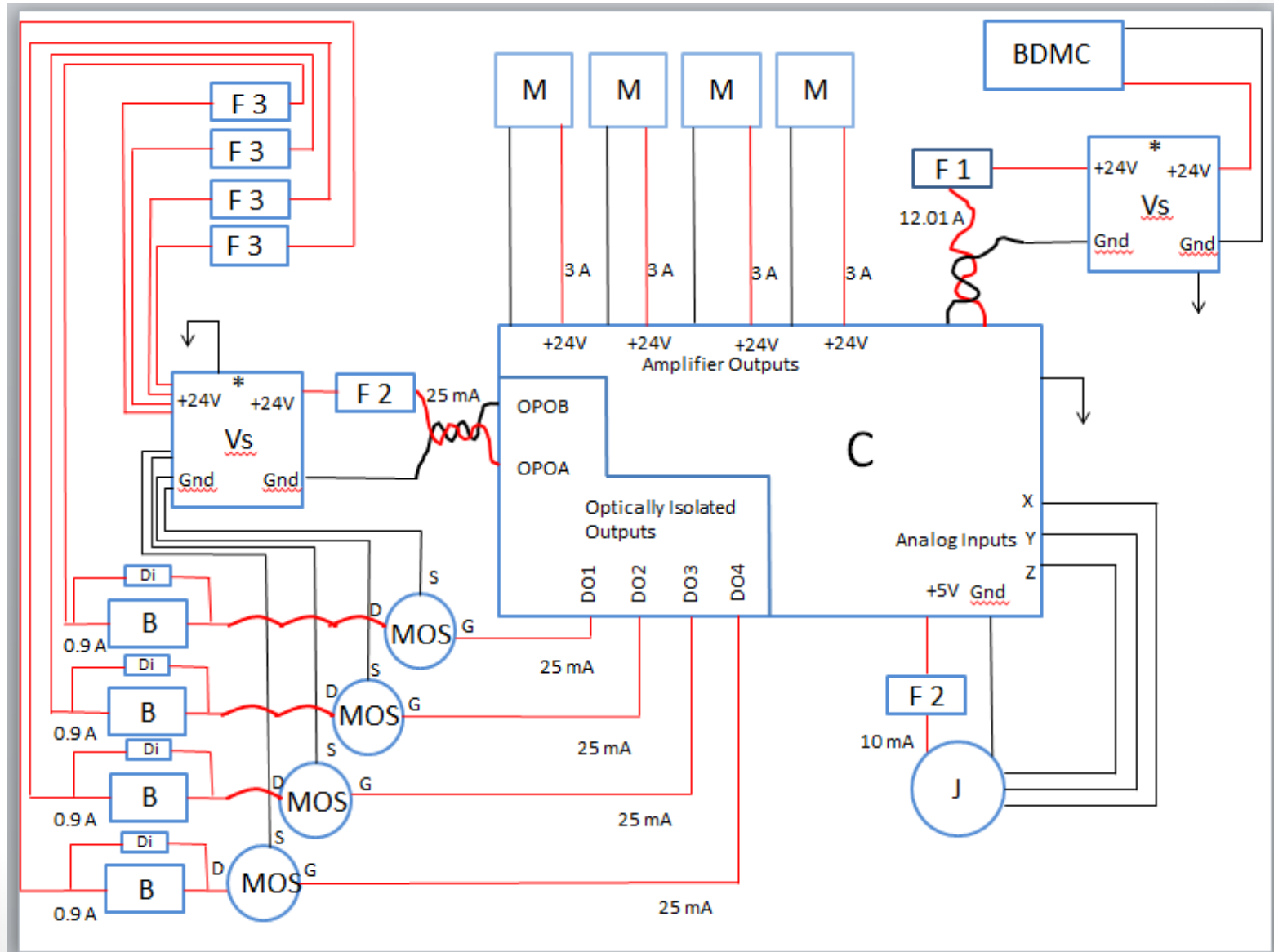

Primary Circuit Components

- Controller
- Stepper Motors
- ERS Brakes
- Joystick
- Connectivity

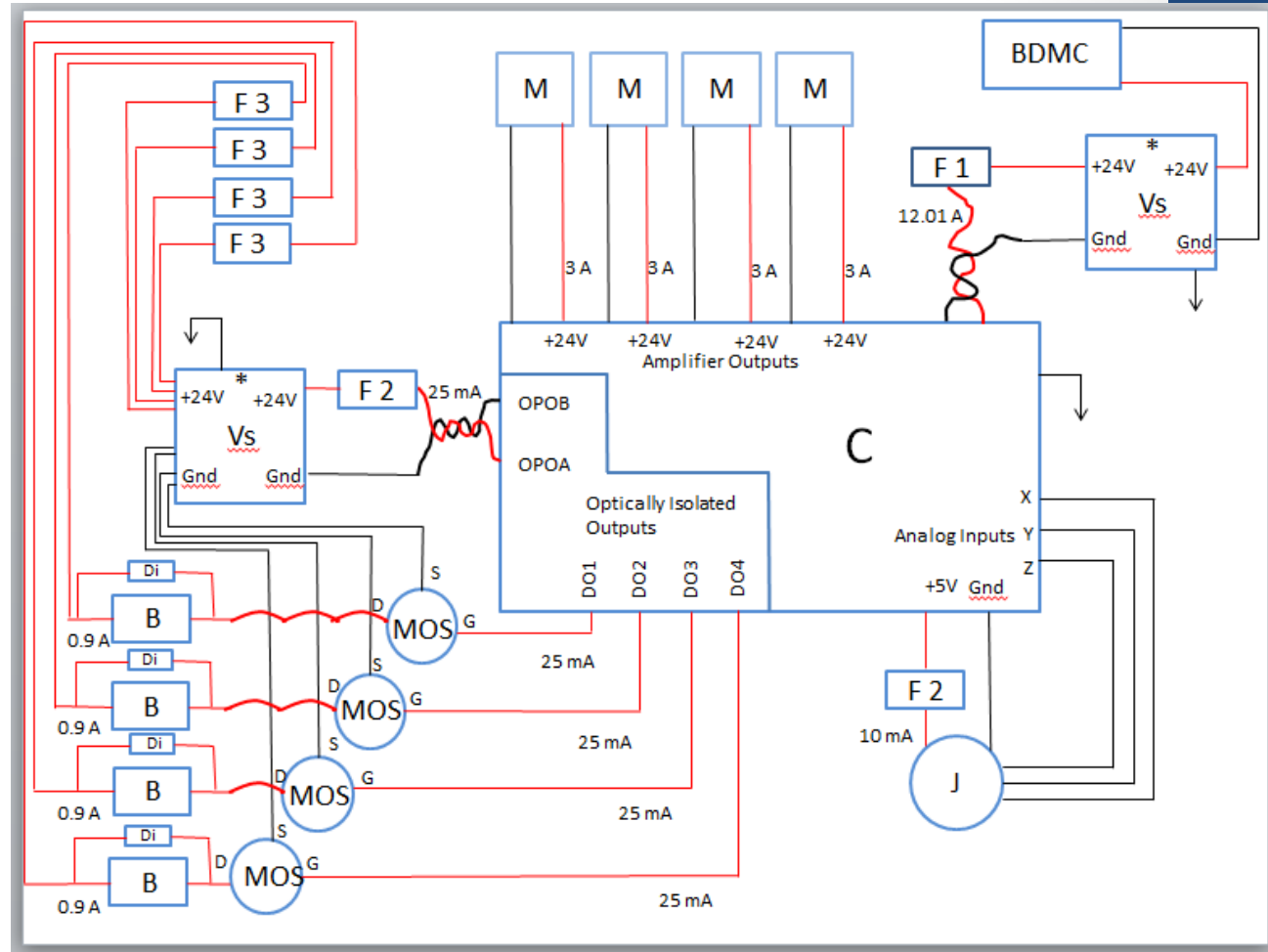

Circuit Protection

- Fuses
- BDMC
- Circuit boxes
- Diodes – Brake Circuit

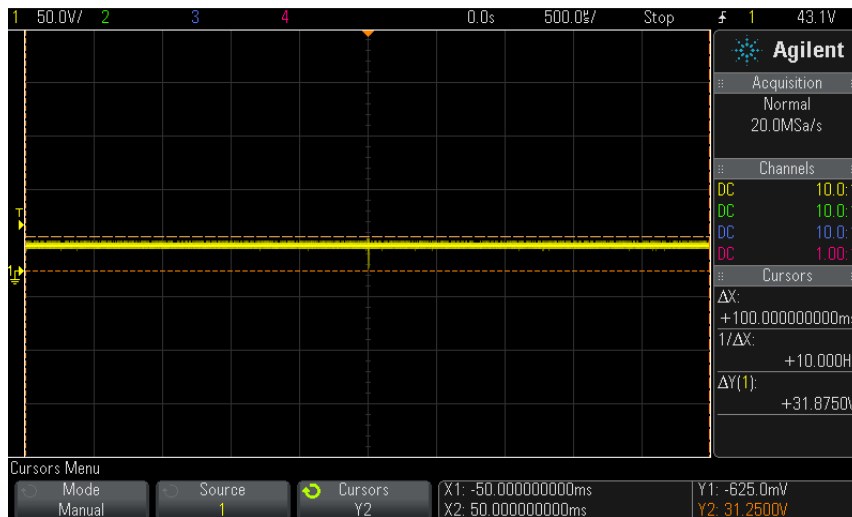

Dissipation Diode

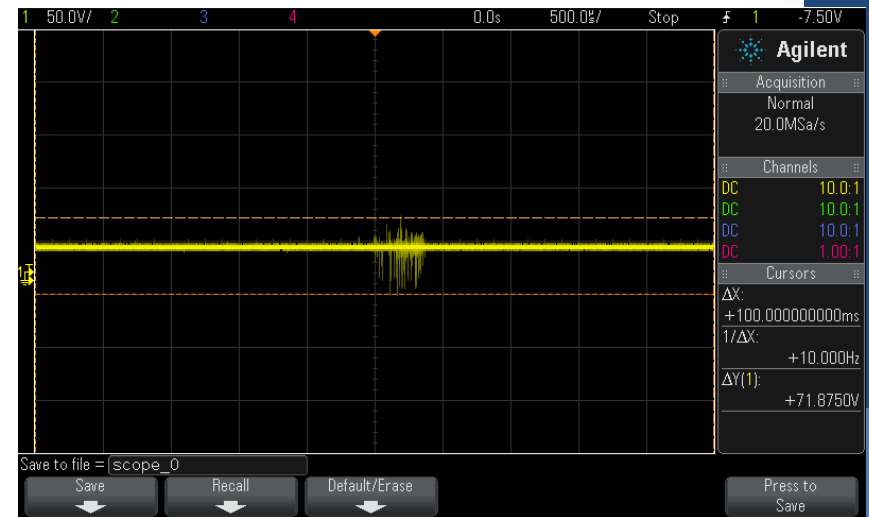

No Protection

Programming

- Programming needs to:
 - Read joystick position
 - Adjust speed of each motor accordingly
 - Engage the brakes when not in motion
 - Shut down everything at the push of a button
- Pre-alpha version of program has been written
- Still need to:
 - Test program with Galil controller, motor, and brake
 - Test program with finished base and circuitry

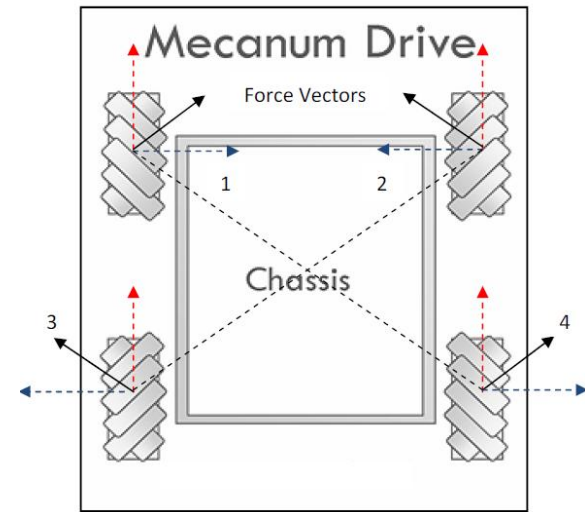

Future Work

- Continue:
 - Fund Raising
 - Material Acquisition
- Construction
 - Finish the base
 - Build the circuit
 - Finalize programming
 - Stability mechanism
- Testing
 - Safety
 - Cadaver and residency testing



Acknowledgements

- Professor Amit Nimunkar
- Dr. Garrett Cuppels
- Marissa Tucker
- Phil Kolmeyer
- Dr. Jones
- Berlin Memorial Hospital Staff
- Professor Willis Tompkins
- Bill Koepcke
- Andrew Norman
- Matty Neikrug
- Lee Sun Kyu
- Individual Donors!

Thank You Corporate Sponsors!



GALIL
WE MOVE THE WORLD



Thank You

